

DISPLAY THIS CARD ON PRINCIPAL FRONTAGE OF WORK



CITY OF PORTLAND BUILDING PERMIT



This is to certify that

DAWSON ERIC J & KRISTINE A DAWSON JTS/Charles
Vispizuoco

PERMIT ID: 2012-65620

Located at

45 TIDE MILL RD

CBL: 212 A049001

has permission to **HVAC Install Bryant 987MA furnace**

provided that the person or persons, firm or corporation accepting this permit shall comply with all of the provisions of the Statutes of Maine and of the Ordinances of the City of Portland regulating the construction, maintenance and use of the buildings and structures, and of the application on file in the department.

Notification of inspection and written permission procured before this building or part thereof is lathed or otherwise closed-in. 48 HOUR NOTICE IS REQUIRED.

A final inspection must be completed by owner before this building or part thereof is occupied. If a certificate of occupancy is required, it must be procured prior to occupancy.

Fire Prevention Officer



Code Enforcement Officer / Plan Reviewer

**THIS CARD MUST BE POSTED ON THE STREET SIDE OF THE PROPERTY
THERE IS A PENALTY FOR REMOVING THIS CARD**

BUILDING PERMIT INSPECTION PROCEDURES
Please call 874-8703 (ONLY)
or email: buildinginspections@portlandmaine.gov

With the issuance of this permit, the owner, builder or their designee is required to provide adequate notice to the city of Portland Inspections Services for the following inspections. Appointments must be requested 48 to 72 hours in advance of the required inspection. The inspection date will need to be confirmed by this office.

- **Please read the conditions of approval that is attached to this permit!! Contact this office if you have any questions.**
- **Permits expire in 6 months. If the project is not started or ceases for 6 months.**
- **If the inspection requirements are not followed as stated below additional fees may be incurred due to the issuance of a "Stop Work Order" and subsequent release to continue.**

REQUIRED INSPECTIONS:

Close-in/Elec./Plmb./Framing
Final Inspection

The project cannot move to the next phase prior to the required inspection and approval to continue, REGARDLESS OF THE NOTICE OF CIRCUMSTANCES.

IF THE PERMIT REQUIRES A CERTIFICATE OF OCCUPANCY, IT MUST BE PAID FOR AND ISSUED TO THE OWNER OR DESIGNEE BEFORE THE SPACE MAY BE OCCUPIED.

City of Portland, Maine - Building or Use Permit

389 Congress Street, 04101 Tel: (207) 874-8703, Fax: (207) 874-8716

Permit No: 201265620	Date Applied For: 12/13/2012	CBL: 212 A049001
--------------------------------	--	----------------------------

Location of Construction: 45 TIDE MILL RD	Owner Name: DAWSON ERIC J & KRISTINE A	Owner Address: 45 TIDE MILL RD	Phone:
Business Name:	Contractor Name: Charles Vispizuoco	Contractor Address: 286 State Park Naples	Phone (207) 232-5513
Lessee/Buyer's Name	Phone:	Permit Type: HVAC	

Proposed Use: Single Family	Proposed Project Description: HVAC Install Bryant 987MA furnace
---------------------------------------	---

Dept: Zoning **Status:** Approved **Reviewer:** Marge Schmuckal **Approval Date:** 12/18/2012
Note: **Ok to Issue:**

Dept: Building **Status:** Approved w/Conditions **Reviewer:** Jon Rioux **Approval Date:** 12/18/2012
Note: **Ok to Issue:**

- 1) The installation must comply with UL, the Manufacturers' Listing, MUBEC (IRC, 2009), and State of Maine Gas Regulations.

Separate permits are required for any electrical: plumbing, sprinkler, fire alarm, HVAC systems, commercial hood exhaust systems and fuel tanks. Separate plans may need to be submitted for approval as a part of this process.

Maintain proper setback(s) from property lines/buildings and proper clearances from vertical openings when direct venting

A Carbon Monoxide (CO) alarm shall be installed in each area within or giving access to bedrooms. That detection must be powered by the electrical service (plug-in or hardwired) in the building and battery.

M1804.2.5 Direct vent terminations. Vent terminals for direct-vent appliances shall be installed in accordance with the manufacturer's installation instructions.

City of Portland, Maine - Building or Use Permit Application

389 Congress Street, 04101 Tel: (207) 874-8703, Fax: (207) 874-8716

Permit No: 2012-65620	Issue Date:	CBL: 212 A049001
--------------------------	-------------	---------------------

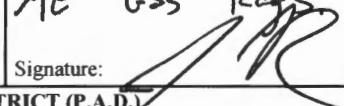
Location of Construction: 45 TIDE MILL RD	Owner Name: DAWSON ERIC J & KRISTINE A	Owner Address: 45 TIDE MILL RD	Phone:
Business Name:	Contractor Name: Charles Vispizuoco	Contractor Address: 286 State Park Naples	Phone (207) 232-5513
Lessee/Buyer's Name	Phone:	Permit Type: HVAC	Zone: R2
Past Use: Single Family	Proposed Use: Single Family	Permit Fee: \$330.00	Cost of Work: \$31,000.00
Proposed Project Description: HVAC Install Bryant 987MA furnace <i>New Single Family home # 2012-05-4074</i>		FIRE DEPT: <input type="checkbox"/> Approved <input type="checkbox"/> Denied <input checked="" type="checkbox"/> N/A	INSPECTION: Use Group: HVAC Type: ME Gas Rags Signature: 
		PEDESTRIAN ACTIVITIES DISTRICT (P.A.D.) Action: <input type="checkbox"/> Approved <input type="checkbox"/> Approved w/Conditions <input type="checkbox"/> Denied Signature: _____ Date: _____	

Permit Taken By: bjs	Date Applied For: 12/13/2012	Zoning Approval		
1. This permit application does not preclude the Applicant(s) from meeting applicable State and Federal Rules. 2. Building permits do not include plumbing, septic or electrical work. 3. Building permits are void if work is not started within six (6) months of the date of issuance. False information may invalidate a building permit and stop all work..		Special Zone or Reviews <input type="checkbox"/> Shoreland <input type="checkbox"/> Wetland <input type="checkbox"/> Flood Zone <input type="checkbox"/> Subdivision <input type="checkbox"/> Site Plan Maj <input type="checkbox"/> Minor <input type="checkbox"/> MM <input type="checkbox"/> Date: <i>12/13/12</i>	Zoning Appeal <input type="checkbox"/> Variance <input type="checkbox"/> Miscellaneous <input type="checkbox"/> Conditional Use <input type="checkbox"/> Interpretation <input type="checkbox"/> Approved <input type="checkbox"/> Denied Date: _____	Historic Preservation <input checked="" type="checkbox"/> Not in District or Landmark <input type="checkbox"/> Does Not Require Review <input type="checkbox"/> Requires Review <input type="checkbox"/> Approved <input type="checkbox"/> Approved w/Conditions <input type="checkbox"/> Denied Date: 

CERTIFICATION

I hereby certify that I am the owner of record of the named property, or that the proposed work is authorized by the owner of record and that I have been authorized by the owner to make this application as his authorized agent and I agree to conform to all applicable laws of this jurisdiction. In addition, if a permit for work described in the application is issued, I certify that the code official's authorized representative shall have the authority to enter all areas covered by such permit at any reasonable hour to enforce the provision of the code(s) applicable to such permit.

SIGNATURE OF APPLICANT	ADDRESS	DATE	PHONE
RESPONSIBLE PERSON IN CHARGE OF WORK, TITLE		DATE	PHONE



FILL IN AND SIGN WITH INK

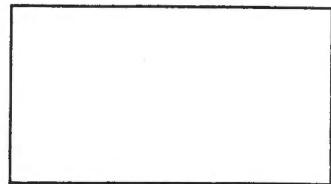

APPLICATION FOR PERMIT HEATING OR POWER EQUIPMENT

Vincent HVAC @ Hotmail.com

To the INSPECTOR OF BUILDINGS, PORTLAND, ME.

The undersigned hereby applies for a permit to install the following heating, cooking or power equipment in accordance with the Laws of Maine, the Building Code of the City of Portland, and the following specifications:

Location / CBL 45 TIDE MILL RD. Use of Building HOME. Date 12/4/12

Name and address of owner of appliance ERIC DAWSON 45 TIDEMILL RD.

Installer's name and address Charles V Spizvolo 266 STATE PARK RD.
Naples, ME 04055 Telephone 232-5513

Location of appliance:

- Basement
- Attic
- Floor
- Roof

Type of Fuel:

- Gas
- Oil
- Solid

Appliance Name: BRYANT

U.L. Approved Yes No

Will appliance be installed in accordance with the manufacture's installation instructions? Yes No

IF NO Explain: _____

The Type of License of Installer:

- Master Plumber # _____
- Solid Fuel # _____
- Oil # MS30002689
- Gas # PNT 1064
- Other _____

Type of Chimney:

- Masonry Lined
Factory built _____
- Metal
Factory Built U.L. Listing # _____
- Direct Vent
Type _____ UL# _____

Type of Fuel Tank

- Oil
- Gas

Size of Tank 1000 gal.

Number of Tanks 1-

Distance from Tank to Center of Flame _____ feet.

Cost of Work: \$ 30,300

Permit Fee: \$ 330.00

Approved

Fire: _____

Ele.: _____

Bldg.: _____

Approved with Conditions

- See attached letter or requirement

Inspector's Signature

Date Approved

Signature of Installer [Signature]

White - Inspection Yellow - File Pink - Applicant's Gold - Assessor's Copy

**987MA
EVOLUTION® MODULATING
4-WAY MULTIPOSE, VARIABLE SPEED
CONDENSING GAS FURNACE, SERIES A**



Product Data

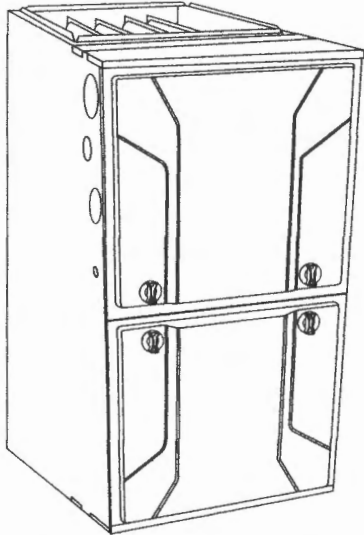

A11264

The 987MA Multipoise Variable-Speed Condensing Gas Furnace features the modulating Evolution® System. The Perfect Heat® Technology modulating gas system is at the heart of the comfort provided by this furnace, along with the variable-speed ECM blower motor, and variable-speed inducer motor. With an Annual Fuel Utilization Efficiency (AFUE) of 97%, the Evolution modulating gas furnace provides exceptional savings as well. This Evolution Gas Furnace also features 4-way multipoise installation flexibility, and is available in four model sizes. The 987MA can be vented for direct vent/two-pipe, ventilated combustion air, or single pipe applications. A Bryant Evolution Control and Evolution Air Conditioner or Heat Pump, can be used to form a complete Evolution System. All units meet California Air Quality Management District emission requirements. All sizes are design certified in Canada.

STANDARD FEATURES

- Evolution System; compatible with **single- and multi-zone** Evolution systems
- Evolution Features—match with the Evolution Control for Evolution System benefits
- Quiet operation. Compare for yourself at HVACpartners.com
- Ideal height 35" (889 mm) cabinet: short enough for taller coils,

- but still allows enough room for service
- Silicon Nitride Perfect Light™ Hot Surface Igniter
- SmartEvap™ technology helps control humidity levels in the home when used with a compatible humidity control system
- FanOn Plus™ technology allows control of continuous fan speed from a compatible thermostat
- External Media Filter Cabinet included
- 4-way multipoise design for upflow, downflow or horizontal installation with unique vent elbow and optional through-the-cabinet downflow venting capability
- Aluminized-steel primary heat exchanger
- Stainless-steel condensing secondary heat exchanger
- Propane convertible (See Accessory list)
- Factory-configured ready for upflow applications
- Fully-insulated casing including blower section
- Convenient Electronic Air Cleaner and Humidifier connections
- Direct-vent/sealed combustion, single-pipe venting or ventilated combustion air
- Installation flexibility: sidewall or vertical vent
- Residential installations may be eligible for consumer financing through the Retail Credit Program
- Variable-Speed blower motor, variable-speed inducer motor, and modulating gas valve
- Self-diagnostics and extended diagnostic data through the Advanced Product Monitor (APM) accessory or Evolution User Interface
- Adjustable blower speed for cooling, continuous fan, and dehumidification

LIMITED WARRANTY*

- 10 year parts and lifetime heat exchanger limited warranty to the original purchaser upon timely registration.
- Limited warranty period is five years for parts and twenty years for the heat exchanger if not registered within 90 days of installation.†

* For owner occupied, residential applications.

† Jurisdictions where warranty benefits cannot be conditioned on registration will receive registered limited warranty benefits.

**EVOLUTION™
SYSTEM**



Use of the AHRI Certified™ Mark indicates a manufacturer's participation in the program. For verification of certification for individual products, go to www.ahridirectory.org.



Always Ask For
**FACTORY
AUTHORIZED
PARTS**

SPECIFICATIONS

Heating Capacity and Efficiency			042060	042080	060100	066120
Input	Maximum Heat	(BTUH)	60,000	80,000	100,000	120,000
	Intermediate Heat	(BTUH)	39,000	52,000	65,000	78,000
	Minimum Heat	(BTUH)	24,000	32,000	40,000	48,000
Output	Maximum Heat	(BTUH)	59,000	78,000	97,000	117,000
	Intermediate Heat	(BTUH)	38,000	51,000	63,000	76,000
	Minimum Heat	(BTUH)	24,000	31,000	39,000	47,000
Efficiency	AFUE % (ICS)		97.0	97.0	97.0	97.0
Certified Temperature Rise Range °F (°C)	Maximum Heat		35 - 65 (19-36)	40 - 70 (21-38)	45 - 75 (25-41)	45 - 75 (25-41)
	Intermediate Heat		50 - 80 (27-44)	50 - 80 (27-44)	50 - 80 (27-44)	50 - 80 (27-44)
	Minimum Heat		35 - 65 (19-36)	35 - 65 (19-36)	35 - 65 (19-36)	35 - 65 (19-36)
Airflow Capacity and Blower Data			042060	042080	060100	066120
Certified External Static Pressure (in. w.c.)	Heating		0.12	0.15	0.20	0.20
	Cooling		0.5	0.5	0.5	0.5
Airflow Delivery @ Rated ESP (CFM)	Maximum Heat		1075	1510	1515	1815
	Intermediate Heat		530	750	905	1100
	Minimum Heat		415	620	725	900
	Cooling		1335	1375	2030	2185
Cooling Capacity (tons) @ 400, 350 CFM/ton	400 CFM/ton		3	3.5	5	5.5
	350 CFM/ton		3.5	4	5.5	6
Direct-Drive Motor Type	Electronically Commutated Motor (ECM)					
Direct-Drive Motor HP			1/2	1/2	1	1
Motor Full Load Amps			7.7	7.7	12.8	12.8
RPM Range	300 - 1300					
Speed Selections	Variable (Communicating)					
Blower Wheel Dia. X Width	in.		11 x 8	11 x 8	11 x 10	11 x 11
Air Filtration System	Factory Supplied Media Cabinet Field Supplied Filter					
Filter Used for Certified Watt Data			KGAWF1306UFR	KGAWF1306UFR	KGAWF1406UFR	KGAWF1506UFR
Electrical Data			042060	042080	060100	066120
Input Voltage	Volts-Hertz-Phase		115-60-1			
Operating Voltage Range	Min-Max		104-127			
Maximum Input Amps	Amps		9.7	9.7	14.8	14.8
Unit Ampacity	Amps		12.7	12.7	19.1	19.1
Minimum Wire Size	AWG		14	14	12	12
Maximum Wire Length @ Minimum Wire Size	Feet		29	29	30	30
	(M)		(8.8)	(8.8)	(9.1)	(9.1)
Maximum Fuse/Ckt Bkr (Time-Delay Type Recommended)	Amps		15	15	20	20
Transformer Capacity (24vac output)	40 VA					
External Control Power Available	Heating		27.9 VA			
	Cooling		34.6 VA			
Controls			042060	042080	060100	066120
Gas Connection Size	1/2" - NPT					
Burners (Monoport)			3	4	5	6
Gas Valve (Redundant)	Manufacturer	White Rogers™				
	Minimum Inlet Gas pressure (in. W.C.)		4.5			
	Maximum Inlet Gas pressure (in. W.C.)		13.6			
Gas Conversion Kit - Natural to Propane	KGANP5201VSP					
Gas Conversion Kit - Propane to Natural	KGAPN4401VSP					
Manufactured (Mobile) Home Kit	not approved for MH use					
Ignition Device	Silicon Nitride					
Limit Control			180	170	160	160
Heating Blower Control (Heating Off-Delay)	Adjustable: 90, 120, 150, 180 seconds					
Cooling Blower Control (Time Delay Relay)	90 seconds					
Communication System	Evolution; Evolution Zoning					
Thermostat Connections	W2, Y1, DHUM, G, COM 24V, W/W1, Y/Y2, R					
Accessory Connections	EAC (115vac); HUM (24vac); 1-stg AC (via Y/Y2)					

186B
EVOLUTION™ 16 HEAT PUMP
WITH PURON® REFRIGERANT
1-1/2 TO 5 TONS



Product Data



EVOLUTION™
SYSTEM

Bryant's Air Conditioners with Puron® refrigerant provide a collection of features unmatched by any other family of equipment. The 186B has been designed utilizing Bryant's Puron refrigerant. The environmentally sound refrigerant allows you to make a responsible decision in the protection of the earth's ozone layer.

As an Energy Star® Partner, Bryant Heating & Cooling has determined that this product meets the Energy Star® guidelines for energy efficiency. Refer to the combination ratings in the Product Data for system combinations that meet Energy Star® guidelines.

NOTE: Ratings contained in this document are subject to change at any time. Always refer to the AHRI directory (www.ahridirectory.org) for the most up-to-date ratings information.

INDUSTRY LEADING FEATURES / BENEFITS

Efficiency

- 14 - 16 SEER / 11.0- 13.5 EER
- Microtube Technology™ refrigeration system
- Indoor air quality accessories available

Sound

- Sound level as low as 68 dBA
- Compressor sound blanket standard

Comfort

- System supports Evolution Control or standard thermostat controls

Reliability

- Puron® refrigerant - environmentally sound, won't deplete the ozone layer and low lifetime service cost.
- Scroll compressor
- Internal pressure relief valve
- Internal thermal overload
- Filter drier
- High and low pressure switches
- Balanced refrigeration system for maximum reliability

Durability

DuraGuard™ protection package:

- Solid, durable sheet metal construction
- Louvered coil guard
- Baked-on, complete outer coverage, powder paint

Applications

- Long-line - up to 250 feet (76.20 m) total equivalent length, up to 200 feet (60.96 m) condenser above evaporator, or up to 80 ft. (24.38 m) evaporator above condenser (See Longline Guide for more information.)
- Low ambient (down to -20°F/-28.9°C) with accessory kit

MODEL NUMBER NOMENCLATURE

1	2	3	4	5	6	7	8	9	10	11	12	14
N	N	N	A	A/N	N	N	N	N	A/N	A/N	N	A
1	8	6	B	N	A	0	1	8	0	0	0	A
Product Family	Tier	SEER	Major Series	Voltage	Variations	Cooling Capacity			Open	Open	Open	Minor Series
1=AC	8= Evolution Series	6=16 SEER Nominal	B=Puron	N= 208-230-1	A= Standard				0=Not Defined	0= Not Defined	0= Not Defined	A = Original Series



Use of the AHRI Certified TM Mark indicates a manufacturer's participation in the program For verification of certification for individual products, go to www.ahridirectory.org.



This product has been designed and manufactured to meet Energy Star® criteria for energy efficiency when matched with appropriate coil components. However, proper refrigerant charge and proper air flow are critical to achieve rated capacity and efficiency. Installation of this product should follow all manufacturing refrigerant charging and air flow instructions. Failure to confirm proper charge and air flow may reduce energy efficiency and shorten equipment life.



186B

STANDARD FEATURES

Feature	18	24	30	36	42	48	60	61
Puron Refrigerant	X	X	X	X	X	X	X	X
Maximum SEER *	16.0	16.0	16.5	16.5	16.0	16.0	16.0	16.0
Scroll Compressor	X	X	X	X	X	X	X	X
Field Installed Filter Drier	X	X	X	X	X	X	X	X
Front Seating Service Valves	X	X	X	X	X	X	X	X
Internal Pressure Relief Valve	X	X	X	X	X	X	X	X
Internal Thermal Overload	X	X	X	X	X	X	X	X
Long Line capability	X	X	X	X	X	X	X	X
Low Ambient capability with Kit	X	X	X	X	X	X	X	X
High Pressure Switch	X	X	X	X	X	X	X	X
Low Pressure Switch	X	X	X	X	X	X	X	X
Compressor Sound Blanket	X	X	X	X	X	X	X	X
Louvered Coil Guard	X	X	X	X	X	X	X	X

*Based on tested combinations

X = Standard

PHYSICAL DATA

UNIT SIZE SERIES	018-A	024-A	030-A	036-A	042-A	048-A	060-A	061-A
Operating Weight lb (Kg)	175.5 (79.6)	176 (79.8)	186.5 (84.6)	200 (90.7)	253 (114.8)	295 (133.8)	327 (148.3)	326 (147.9)
Shipping Weight lb (Kg)	212.5 (96.4)	211.5 (95.9)	222.5 (100.9)	243 (110.2)	297 (134.7)	340 (154.2)	373.5 (169.4)	373 (169.2)
Compressor Type	Scroll							
REFRIGERANT	R-410A							
Control	TXV (R-410A Hard Shutoff)							
Charge lb (Kg)	5.25 (2.38)	6.00 (2.72)	6.81 (3.09)	7.00 (3.18)	8.62 (3.91)	13.00 (5.9)	14.50 (6.58)	14.50 (6.58)
COND FAN	Propeller Type, Direct Drive							
Air Discharge	Vertical							
Air Qty (CFM)	2233	2614	2614	3223	3810	4046	4046	4046
Motor HP	1/12	1/10	1/10	1/12	1/5	1/4	1/4	1/4
Motor RPM	800	800	800	800	800	800	800	800
COND COIL								
Face Area (Sq ft)	15.07	15.07	17.22	17.58	25.12	25.12	30.14	30.14
Fins per In.	25	25	25	25	25	20	20	20
Rows	1	1	1	1	1	2	2	2
Circuits	3	4	4	4	6	7	8	8
VALVE CONNECT. (In. ID)								
Vapor	3/4	3/4	3/4	7/8	7/8	7/8	7/8	7/8
Liquid	3/8	3/8	3/8	3/8	3/8	3/8	3/8	3/8
REFRIGERANT TUBES (In. OD)								
Rated Vapor*	3/4			7/8			1-1/8	
Max Liquid Line					3/8"			

*Units are rated with 25 ft (7.6 m) of lineset length. See Vapor Line Sizing and Cooling Capacity Loss table when using other sizes and lengths of lineset.

NOTE: See unit Installation Instruction for proper installation.

DIMENSIONS - ENGLISH

UNIT	SERIES	ELECTRICAL CHARACTERISTICS					A	B	C	D	E	F	G	K	L	M	N	P	OPERATING WEIGHT (lbs)	SHIPPING WEIGHT (lbs)	SHIPPING DIMENSIONS (L x W x H)
186B018	A	X	0	0	0	31 3/16"	28 11/16"	3 3/4"	3/4"	6 9/16"	24 11/16"	9 1/8"	2 13/16"	1/2"	15 1/2"	17"	14"	175.5	212.5	32 15/16" X 35 1/2" X 32 9/16"	
186B024	A	X	0	0	0	31 3/16"	28 11/16"	3 3/4"	3/4"	6 9/16"	24 11/16"	9 1/8"	2 13/16"	1/2"	16 1/4"	15 1/4"	14"	176	211.5	32 15/16" X 35 1/2" X 32 9/16"	
186B030	A	X	0	0	0	31 3/16"	32 1/8"	3 3/4"	3/4"	6 9/16"	24 11/16"	9 1/8"	2 13/16"	1/2"	15"	15 3/4"	14 3/4"	186.5	222.5	32 15/16" X 35 1/2" X 35 15/16"	
186B036	A	X	0	0	0	35"	30 1/16"	3 7/8"	7/8"	6 9/16"	28 11/16"	8 1/8"	2 15/16"	5/8"	17"	16 3/4"	14"	200	243	36 1/8" X 39 1/4" X 35 15/16"	
186B042	A	X	0	0	0	35"	40 1/4"	3 7/8"	7/8"	6 9/16"	28 7/16"	9 1/8"	2 15/16"	5/8"	17"	16"	18 1/2"	253	297	36 1/8" X 39 1/4" X 46 1/8"	
186B048	A	X	0	0	0	35"	40 1/4"	3 7/8"	7/8"	6 9/16"	28 7/16"	9 1/8"	2 15/16"	5/8"	17 1/2"	16 1/4"	18"	295	340	38 1/8" X 39 1/4" X 46 1/8"	
186B060	A	X	0	0	0	35"	47 1/16"	3 7/8"	7/8"	6 9/16"	28 7/16"	9 1/8"	2 15/16"	5/8"	17 1/2"	17 1/4"	21"	327	373.5	36 1/8" X 39 1/4" X 51 13/16"	
186B061	A	X	0	0	0	35"	47 1/16"	3 7/8"	7/8"	6 9/16"	28 7/16"	9 1/8"	2 15/16"	5/8"	17 1/4"	17"	21"	328	373	36 1/8" X 39 1/4" X 51 13/16"	

208-230-160
230-160
208/230-3-60
460-3-60

X = YES
O = NO

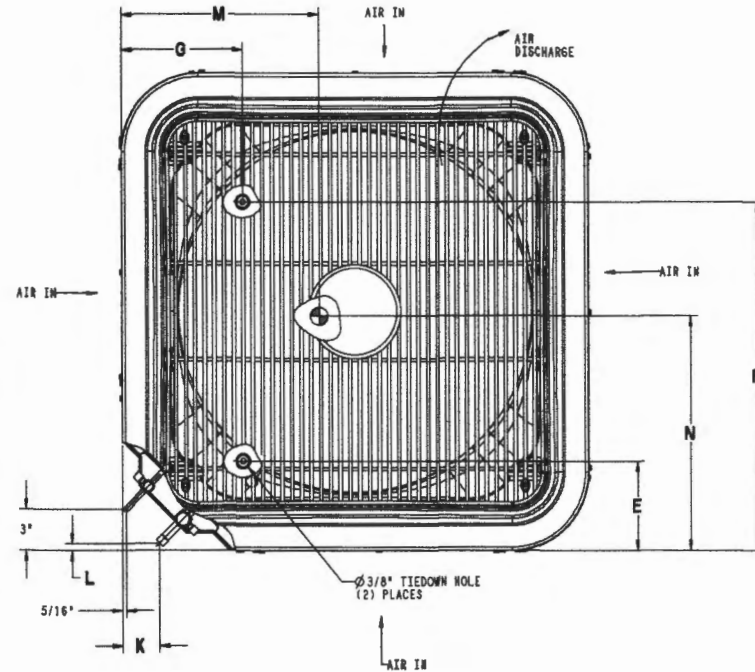
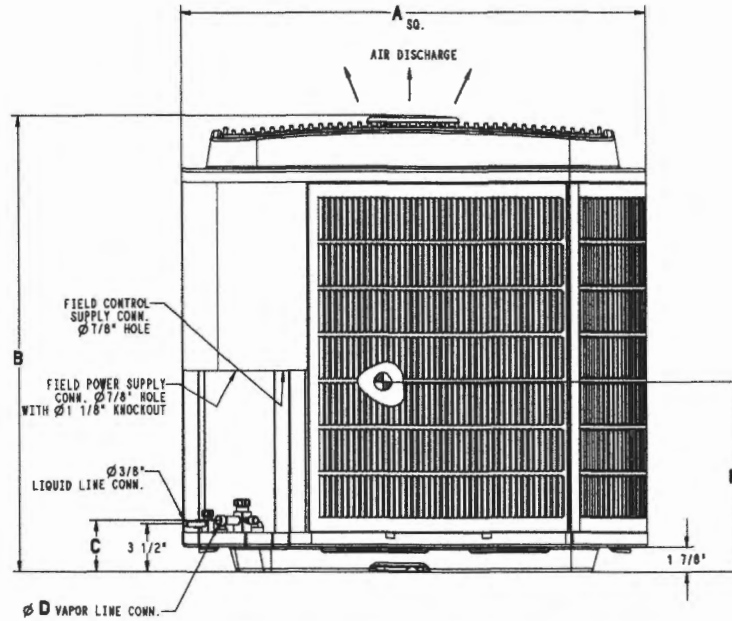

UNIT SIZE	MINIMUM MOUNTING PAD DIMENSIONS
-	26" X 26"
18, 24, 30	31 1/2" X 31 1/2"
36, 42, 48, 60, 61	35" X 35"

Brad Saucier - Fwd: 987MA

From: CHARLES SPIZUOCO <vincenthvac@hotmail.com>
To: Brad Saucier <BJS@portlandmaine.gov>
Date: 12/19/2012 8:52 AM
Subject: Fwd: 987MA

Venting 2 inch concentric through the roof on the back side half way down the side of the structure.
Basement concentric through the back of the structure on the right end facing the rear.

Sent from my iPhone

Begin forwarded message:

From: "Lannquist, Eric" <Eric.Lannquist@carrierenterprise.com>
To: "CHARLES SPIZUOCO" <vincenthvac@hotmail.com>
Subject: 987MA

Eric R. Lannquist
Bryant Northeast
Sales Center Manager
Scarborough, Maine 04074
P : 207-885-0140 Opt 8
F : 207-885-0152
[cid:image001.png@01CDDDC0.E6C14EA0]

<image001.png>

<987MA-PRODUCT DATA.pdf>

**987MA
EVOLUTION® MODULATING
4-WAY MULTIPOISE, VARIABLE SPEED
CONDENSING GAS FURNACE, SERIES A**



Product Data

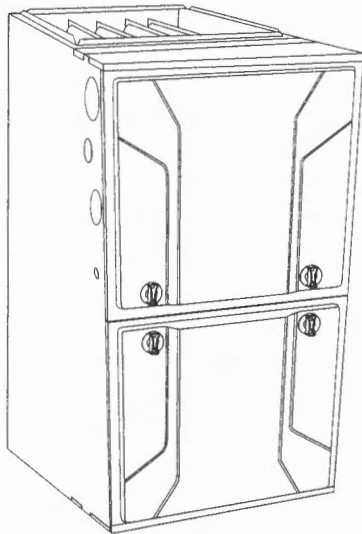

A11264

The 987MA Multipoise Variable-Speed Condensing Gas Furnace features the modulating Evolution® System. The Perfect Heat® Technology modulating gas system is at the heart of the comfort provided by this furnace, along with the Perfect ECM™ full-featured variable-speed communicating blower motor, and variable-speed inducer motor. With an Annual Fuel Utilization Efficiency (AFUE) of up to 98.3%, the Evolution modulating gas furnace provides exceptional savings as well. This Evolution Gas Furnace also features 4-way multipoise installation flexibility, and is available in six model sizes. The 987MA can be vented for direct vent/two-pipe, ventilated combustion air, or single pipe applications. A Bryant Evolution Control and Evolution Air Conditioner or Heat Pump, can be used to form a complete Evolution System. All units meet California Air Quality Management District emission requirements. All sizes are design certified in Canada.

STANDARD FEATURES

- Evolution System; compatible with **single- and multi-zone** Evolution systems.
- Evolution Features—match with the Evolution Control for Evolution System benefits.
- All sizes meet ENERGY STAR® Version 4.0 criteria for gas furnaces: 95+AFUE; AMACF electrical rating; 2% or less cabinet airflow leakage.
- Quiet operation. Compare for yourself at HVACpartners.com.
- Ideal height 35" (889 mm) cabinet: short enough for taller coils, but still allows enough room for service.
- Silicon Nitride Perfect Light™ Hot Surface Igniter.
- SmartEvap™ technology helps control humidity levels in the home when used with a compatible humidity control system.
- FanOn Plus™ technology allows control of continuous fan speed from a compatible thermostat.
- External Media Filter Cabinet included.
- 4-way multipoise design for upflow, downflow or horizontal installation with unique vent elbow and optional through-the-cabinet downflow venting capability.
- Full-featured variable-speed communicating blower motor, variable-speed inducer motor, and modulating gas valve.
- Aluminized-steel primary heat exchanger.
- Stainless-steel condensing secondary heat exchanger.
- Propane convertible (see Accessory list).
- Factory-configured ready for upflow applications.
- Fully-insulated casing including blower section.
- Convenient Air Purifier and Humidifier connections.
- Direct-vent/sealed combustion or ventilated combustion air.
- Installation flexibility: sidewall or vertical vent.
- Residential installations may be eligible for consumer financing through the Retail Credit Program.
- Variable-Speed blower motor, variable-speed inducer motor, and modulating gas valve.
- Self-diagnostics and extended diagnostic data through the Advanced Product Monitor (APM) accessory or Evolution User Interface.
- Adjustable blower speed for cooling, continuous fan, and dehumidification.
- Certified to leak 2% or less of nominal air conditioning CFM delivered when pressurized to 1-in. water column with all present air inlets, air outlets, and condensate drain port(s) sealed.

**EVOLUTION™
SYSTEM**



Use of the AHRM Certified™ Mark indicates a manufacturer's participation in the program. For verification of certification for individual products, go to www.ahrmdirectory.org.



Always Ask For
**FACTORY
AUTHORIZED
PARTS**

SPECIFICATIONS (CONTINUED)

Controls	42060	60060	42080	60080	66100	66120
Limit Control	180	160	170	200	180	160
Heating Blower Control (Heating Off-Delay)	Adjustable: 90, 120, 150, 180 seconds					
Cooling Blower Control (Time Delay Relay)	90 seconds					
Communication System	Evolution, Evolution Zoning					
Thermostat Connections	R, W/W1, W2 Y/Y2, Y1, G, Com 24V, DHUM					
Accessory Connections	EAC (115vac); HUM (24vac); 1-stg AC (via Y/Y2)					

MODEL NUMBER NOMENCLATURE

Example of a Model Number

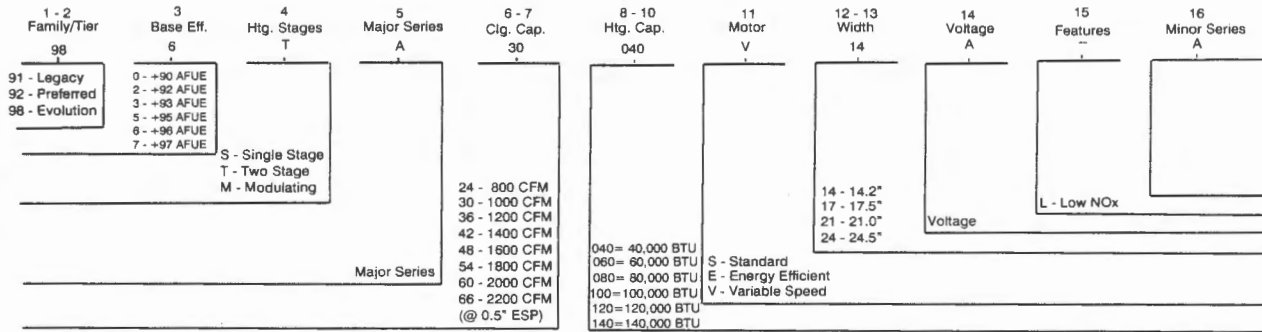

Not all families have these models.

A12374

FURNACE COMPONENTS

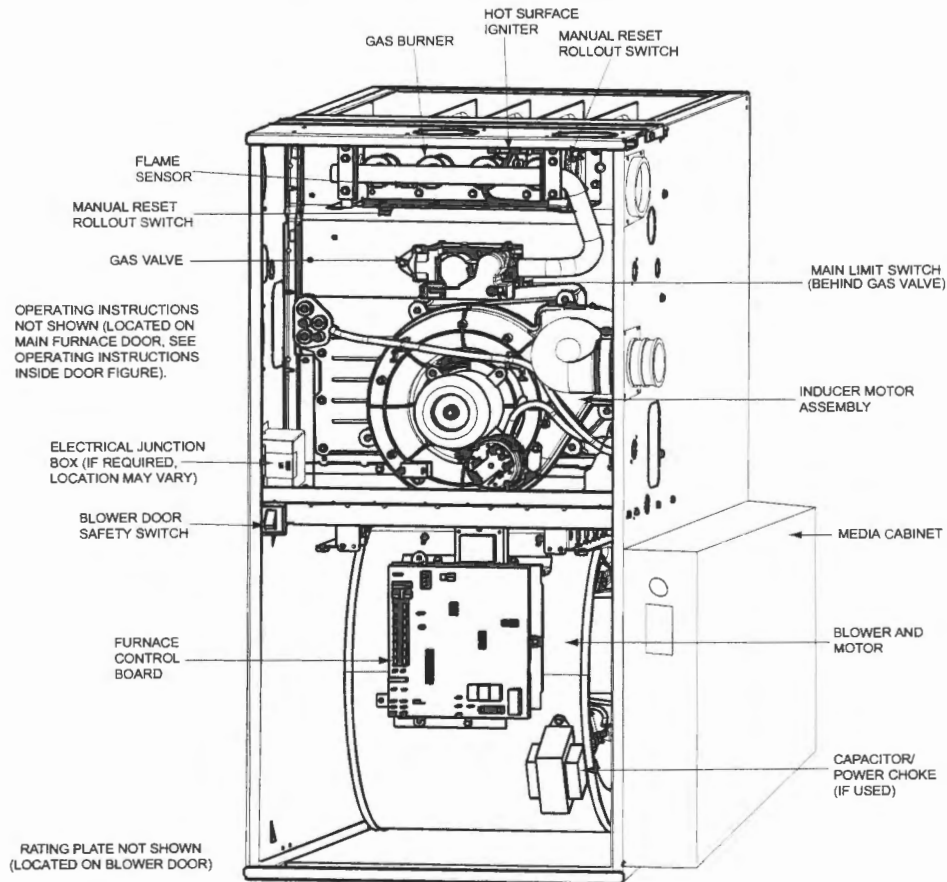

REPRESENTATIVE DRAWING ONLY, SOME MODELS MAY VARY IN APPEARANCE.

A11408

987MA

ACCESSORIES

DESCRIPTION	PART NUMBER	42069	60060	42080	60080	66100	66120
Venting Accessories							
Vent Kit - Through the Cabinet	KGADC0101BVC	•	•	•	•	•	•
Vent Terminal - Concentric - 2" (51 mm)	KGAVT0701CVT	See Venting Tables					
Vent Terminal - Concentric - 3" (76 mm)	KGAVT0801CVT						
Vent Terminal Bracket - 2" (51 mm)	KGAVT0101BRA						
Vent Terminal Bracket - 3" (76 mm)	KGAVT0201BRA						
Vent Kit - Rubber Coupling	KGAAC0101RVC	See Venting Tables					
Condensate Drainage Accessories							
Freeze Protect Kit - Heat Tape	KGAAHT0101CFP	•	•	•	•	•	•
CPVC to PVC Drain Adapters - 1/2" CPVC to 3/4" PVC	KGAAD0110PVC	•	•	•	•	•	•
Horizontal Trap Grommet - Direct Vent	KGACK0101HCK	All DV Horizontal					
Condensate Neutralizer Kit	P908-0001	•	•	•	•	•	•
External Trap Kit	KGAET0201ETK	•	•	•	•	•	•
Ductwork Adapter Accessories							
Furnace Base Kit for Combustible Floors	KGASB0201ALL	•	•	•	•	•	•
Coil Adapter Kits - No Offset	KGADA0101ALL	•	•	•	•	•	•
Coil Adapter Kits - Single Offset	KGADA0201ALL	•	•	•	•	•	•
Coil Adapter Kits - Double Offset	KGADA0301ALL	•	•	•	•	•	•
Return Air Base (Upflow Applications) 17.5-in. wide	KGARP0301B17	•	•	•	•	•	•
Return Air Base (Upflow Applications) 21.0-in. wide	KGARP0301B21	•	•	•	•	•	•
Return Air Base (Upflow Applications) 24.5-in. wide	KGARP0301B24	•	•	•	•	•	•
IAQ Device Duct Adapters 20.0-in. IAQ to 16 in. Side Return	KGAAD0101MEC	20"x25" IAQ Devices					
IAQ Device Duct Adapters 24.0-in. IAQ to 16 in. Side Return	KGAAD0201MEC	24"x25" IAQ Devices					
Gas Conversion Accessories							
Gas Conversion Kit - Nat to LP; Var-speed Products	KGANP5201VSP	•	•	•	•	•	•
Gas Conversion Kit - LP to Nat; Var-speed Products	KGAPN4401VSP	•	•	•	•	•	•
Gas Orifice Kit - #42 (Nat Gas)	LH32DB207	•	•	•	•	•	•
Gas Orifice Kit - #43 (Nat Gas)	LH32DB202	•	•	•	•	•	•
Gas Orifice Kit - #44 (Nat Gas)	LH32DB200	•	•	•	•	•	•
Gas Orifice Kit - #45 (Nat Gas)	LH32DB205	•	•	•	•	•	•
Gas Orifice Kit - #46 (Nat Gas)	LH32DB208	•	•	•	•	•	•
Gas Orifice Kit - #47 (Nat Gas)	LH32DB078	•	•	•	•	•	•
Gas Orifice Kit - #48 (Nat Gas)	LH32DB076	•	•	•	•	•	•
Gas Orifice Kit - #54 (LP)	LH32DB203	•	•	•	•	•	•
Gas Orifice Kit - #55 (LP)	LH32DB201	•	•	•	•	•	•
Gas Orifice Kit - #56 (LP)	LH32DB206	•	•	•	•	•	•
Gas Orifice Kit - 1.25mm (LP)	LH32DB209	•	•	•	•	•	•
Gas Orifice Kit - 1.30mm (LP)	LH32DB210	•	•	•	•	•	•
Control Accessories							
ECM Motor Simulator Kit	KGBSD0301FMS	•	•	•	•	•	•
Advanced Product Monitor - APM	KGASD0301APM	•	•	•	•	•	•
Evolution™ Control User Interface	SYSTXBUID01-V	•	•	•	•	•	•
Evolution™ Control Zoning User Interface	SYSTXBUIZ01-V	•	•	•	•	•	•
IAQ Accessories							
Filter Pack (6 pack) - Washable - 16x25x1 (406x635x25 mm)	KGAWF1306UFR	•	•	•	•	•	•
Filter Pack (6 pack) - Washable - 24x25x1 (610x635x25 mm)	KGAWF1506UFR	•	•	•	•	•	•
EZ-Flex Filter - 16" (406 mm)	EXPXXFIL0016	Use with EZXCAB-1016					
EZ-Flex Filter - 20" (508 mm)	EXPXXFIL0020	Use with EZXCAB-1020					
EZ-Flex Filter - 24" (610 mm)	EXPXXFIL0024	Use with EZXCAB-1024					
EZ-Flex Filter with End Caps - 16" (406 mm)	EXPXXUNV0016	Use with EZXCAB-1016					
EZ-Flex Filter with End Caps - 20" (508 mm)	EXPXXUNV0020	Use with EZXCAB-1020					
EZ-Flex Filter with End Caps - 24" (610 mm)	EXPXXUNV0024	Use with EZXCAB-1024					
Cartridge Media Filter - 16" (406 mm)	FILXXCAR0016	Use with FILCABXL-1016					
Cartridge Media Filter - 20" (508 mm)	FILXXCAR0020	Use with FILCABXL-1020					
Cartridge Media Filter - 24" (610 mm)	FILXXCAR0024	Use with FILCABXL-1024					
Bryant Perfect Air Purifier - 16x25 (406x635 mm)	GAPAXBB1625-A08	Up to 1600 CFM					
Bryant Perfect Air Purifier - 20x25 (508x635 mm)	GAPAXBB2025-A08	Up to 2000 CFM					
Bryant Perfect Air Purifier Repl. Filter- 16x25 (406x635 mm)	GAPABBCAR1625-A05	Use with GAPAXBB1625					
Bryant Perfect Air Purifier Repl. Filter- 20x25 (508x635 mm)	GAPABBCAR2025-A05	Use with GAPAXBB2025					
Bryant Preferred Air Purifier - 16x25 (508x635 mm)	PGAPXX1625	Up to 1600 CFM					
Bryant Preferred Air Purifier - 20x25 (508x635 mm)	PGAPXX2025	Up to 2000 CFM					
Bryant Preferred Air Purifier Repl Filter - 16x25 (406x635 mm)	PGAPXXCAR1625	Use with PGAPXX1625					
Bryant Preferred Air Purifier Repl. Filter - 20x25 (508x635 mm)	PGAPXXCAR2025	Use with PGAPXX2025					

• = Used with the model furnace

987MA

AIR DELIVERY - CFM

Cooling⁴ and Heating Air Delivery - CFM (Bottom Return⁵ With Filter)
(SW1-5 and SW4-3 set to OFF, except as indicated. See notes 1 and 2)

Unit Size	Clg/CF Switch Settings			External Static Pressure (ESP)									
	SWx-3	SWx-2	SWx-1	0.1	0.2	0.3	0.4	0.5	0.6	0.7	0.8	0.9	1.0
42060													
Clg Default:	OFF	OFF	OFF	1060	1070	1080	1080	1075	1065	1050	1035	1025	1010
CF Default:	OFF	OFF	OFF	545	530	520	525	510	See note 4				
Cooling (SW2) Cont Fan (SW3)	OFF	OFF	ON	545	530	520	525	510	See note 4				
	OFF	ON	OFF	710	710	710	695	690	See note 4				
	OFF	ON	ON	875	880	890	895	895	890	885	880	870	855
	ON	OFF	OFF	1060	1070	1080	1080	1075	1065	1050	1035	1025	1010
	ON	OFF	ON	1235	1240	1250	1255	1255	1250	1230	1190	1155	1115
	ON	ON	OFF	1235	1240	1250	1255	1255	1250	1230	1190	1155	1115
ON	ON	ON	1235	1240	1250	1255	1255	1250	1230	1190	1155	1115	
Clg SW2:	Maximum Clg Airflow ²			1425	1425	1405	1370	1335	1300	1260	1225	1190	1155
Heating (SW1)	Maximum Heat Airflow ³			1075	1085	1095	1095	1090	1080	1065	1050	1035	1020
	Intermediate Heat Airflow ³			535	515	505	515	495	See note 4				
	Minimum Heat Airflow ³			420	410	415	400	380	See note 4				
80060													
Clg Default:	OFF	OFF	OFF	1735	1735	1725	1715	1700	1685	1665	1650	1625	1605
CF Default:	OFF	OFF	OFF	545	530	520	525	510	See note 4				
Cooling (SW2) Cont Fan (SW3)	OFF	OFF	ON	540	525	525	520	540	See note 4				
	OFF	ON	OFF	680	725	725	720	720	See note 4				
	OFF	ON	ON	925	915	910	895	900	890	875	865	860	855
	ON	OFF	OFF	1070	1075	1080	1070	1080	1075	1055	1045	1030	1020
	ON	OFF	ON	1215	1245	1235	1220	1210	1200	1195	1185	1175	
	ON	ON	OFF	1380	1385	1395	1390	1395	1390	1380	1365	1355	1340
ON	ON	ON	1735	1735	1725	1715	1700	1685	1665	1650	1625	1605	
Clg SW2:	Maximum Clg Airflow ²			1955	1950	1940	1925	1905	1885	1855	1815	1745	1685
Heating (SW1)	Maximum Heat Airflow ³			1080	1085	1095	1090	1095	1085	1070	1055	1045	1030
	Intermediate Heat Airflow ³			685	725	730	725	730	See note 4				
	Minimum Heat Airflow ³			560	555	555	550	565	See note 4				
42080													
Clg Default:	OFF	OFF	OFF	1055	1065	1080	1075	1065	1050	1045	1035	1025	1005
CF Default:	OFF	OFF	OFF	520	505	505	495	490	See note 4				
Cooling (SW2) Cont Fan (SW3)	OFF	OFF	ON	520	505	505	495	490	See note 4				
	OFF	ON	OFF	665	685	680	660	665	See note 4				
	OFF	ON	ON	885	895	905	900	900	895	885	875	860	845
	ON	OFF	OFF	1055	1065	1080	1075	1065	1050	1045	1035	1025	1005
	ON	OFF	ON	1245	1245	1255	1255	1260	1255	1250	1235	1220	1185
	ON	ON	OFF	1245	1245	1255	1255	1260	1255	1250	1235	1220	1185
ON	ON	ON	1245	1245	1255	1255	1260	1255	1250	1235	1220	1185	
Clg SW2:	Maximum Clg Airflow ²			1520	1485	1450	1415	1375	1335	1300	1265	1225	1190
Heating (SW1)	Maximum Heat Airflow ³			1520	1485	1450	1415	1375	1335	1300	1265	1225	1190
	Intermediate Heat Airflow ³			755	745	755	755	765	See note 4				
	Minimum Heat Airflow ³			620	625	630	620	610	See note 4				

987MA

AIR DELIVERY - CFM (CONTINUED)

Cooling⁴ and Heating Air Delivery - CFM (Bottom Return⁵ With Filter)

(SW1-5 and SW4-3 set to OFF, except as indicated. See notes 1 and 2)

Unit Size	Clg/CF Switch Settings			External Static Pressure (ESP)									
	SWx-3	SWx-2	SWx-1	0.1	0.2	0.3	0.4	0.5	0.6	0.7	0.8	0.9	1.0
60080													
Clg Default:	OFF	OFF	OFF	1745	1755	1755	1760	1755	1750	1745	1725	1705	1685
CF Default:	OFF	OFF	OFF	700	710	750	725	750	See note 4				
Cooling (SW2) Cont Fan (SW3)	OFF	OFF	ON	700	710	750	725	750	See note 4				
	OFF	ON	OFF	830	860	870	890	960	See note 4				
	OFF	ON	ON	1045	1045	1060	1070	1070	1070	1095	1090	1080	1070
	ON	OFF	OFF	1215	1220	1245	1240	1235	1235	1225	1220	1235	1235
	ON	OFF	ON	1370	1370	1390	1390	1400	1395	1400	1390	1390	1385
	ON	ON	OFF	1745	1755	1755	1760	1755	1750	1745	1725	1705	1685
ON	ON	ON	1745	1755	1755	1760	1755	1750	1745	1725	1705	1685	
Clg SW2:	Maximum Clg Airflow ²			1920	1920	1945	1945	1945	1960	1950	1940	1915	1900
Heating (SW1)	Maximum Heat Airflow ³			1340	1355	1370	1385	1380	1385	1400	1400	1385	1380
	Intermediate Heat Airflow ³			780	810	835	840	845	See note 4				
	Minimum Heat Airflow ³			595	595	600	595	605	See note 4				
66100													
Clg Default:	OFF	OFF	OFF	1820	1825	1840	1845	1840	1835	1825	1805	1780	1770
CF Default:	OFF	OFF	OFF	750	740	745	730	715	See note 4				
Cooling (SW2) Cont Fan (SW3)	OFF	OFF	ON	750	740	745	730	715	See note 4				
	OFF	ON	OFF	900	900	915	910	905	See note 4				
	OFF	ON	ON	1070	1075	1095	1095	1090	1085	1095	1080	1065	1070
	ON	OFF	OFF	1280	1285	1305	1305	1310	1305	1295	1300	1290	1285
	ON	OFF	ON	1440	1445	1465	1465	1470	1485	1480	1485	1475	1460
	ON	ON	OFF	1820	1825	1840	1845	1840	1835	1825	1805	1780	1770
ON	ON	ON	2135	2140	2140	2135	2140	2130	2115	2100	2070	2015	
Clg SW2:	Maximum Clg Airflow ²			2160	2165	2175	2170	2160	2150	2135	2120	2065	2020
Heating (SW1)	Maximum Heat Airflow ³			1570	1575	1595	1595	1600	1605	1600	1600	1590	1575
	Intermediate Heat Airflow ³			950	955	965	975	970	See note 4				
	Minimum Heat Airflow ³			755	745	750	735	720	See note 4				
66120⁶													
Clg Default:	OFF	OFF	OFF	1850	1855	1860	1855	1850	1830	1805	1775	1750	1730
CF Default:	OFF	OFF	OFF	930	925	915	900	885	See note 4				
Cooling (SW2) Cont Fan (SW3)	OFF	OFF	ON	765	745	740	705	680	See note 4				
	OFF	ON	OFF	930	925	915	900	885	See note 4				
	OFF	ON	ON	1095	1100	1110	1105	1085	See note 4				
	ON	OFF	OFF	1265	1255	1265	1280	1275	1285	1270	1260	1250	1230
	ON	OFF	ON	1465	1455	1470	1465	1465	1470	1455	1450	1435	1415
	ON	ON	OFF	1850	1855	1860	1855	1850	1830	1805	1775	1750	1730
ON	ON	ON	2200	2200	2200	2190	2185	2170	2145	2085	1990	1890	
Clg SW2:	Maximum Clg Airflow ²			2200	2200	2200	2190	2185	2170	2145	2085	1990	1890
Heating (SW1)	Maximum Heat Airflow ³			1815	1820	1825	1820	1815	1795	1775	1745	1720	1700
	Intermediate Heat Airflow ³			1095	1100	1110	1105	1085	See note 4				

1. Nominal 350 CFM/ton cooling airflow is delivered with SW1-5 and SW4-3 set to OFF.

Set SW1-5 to ON for nominal 400 CFM/ton (+15% airflow).

Set SW4-3 to ON for nominal 325 CFM/ton (-7% airflow).

Set both SW1-5 and SW4-3 to ON for nominal 370 CFM/ton (+7% airflow).

The above adjustments in airflow are subject to motor horsepower range/capacity.

2. Maximum cooling airflow is achieved when switches SW2-1, SW2-2, SW2-3 and SW1-5 are set to ON, and SW4-3 is set to OFF.

3. All heating CFM's are when low/medium heat rise adjustment switch (SW1-3) and comfort/efficiency adjustment switch (SW1-4) are both set to OFF.

4. Ductwork must be sized for high-heating CFM within the operational range of ESP. Operation within the blank areas of the chart is not recommended because high-heat operation will be above 1.0 ESP.

5. All airflows on 21" casing size furnaces are 5% less on side return only installations.

6. Side returns for 24.5" casing sizes require two sides, or side and bottom, to allow sufficient airflow at the return of the furnace.

987MA