

SPACE AND BULK REQUIREMENTS – LOT 18

ZONE – R-2 RESIDENTIAL

MINIMUM LOT SIZE: 10,000 S.F.

MINIMUM FRONTAGE: 50 Fr.

MINIMUM SETBACKS: 25 FT.
FRONT YARD 25 FT.
REAR YARD 25 FT.
SIDE YARD

1 STORY 12 FT.
1 1/2 STORY 12 Fr.
2 STORY 14 FT.
2 1/2 STORY 16 FT.

MINIMUM LOT WIDTH: 80 FT

* THE WIDTH OF ONE (1) SIDE YARD MAY BE REDUCED ONE (1) FOOT FOR EVERY FOOT THAT THE OTHER SIDE YARD IS CORRESPONDINGLY INCREASED, BUT NO SIDE YARD SHALL BE LESS THAN EIGHT (8) FEET IN WIDTH.

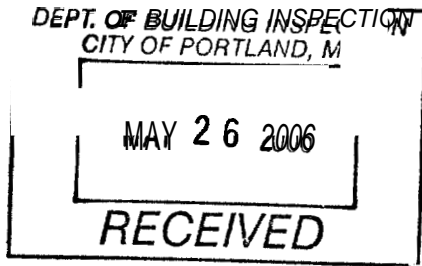

Used for
Zoning

S:\Land Projects\1484\dwg\1484-SP.dwg, Layout1, 5/26/2006 9:03:58 AM, bvandamm, Gorill Palmer Consulting Engineers, Inc.

Design: DER	Date: JAN 2006
Draft: CAH	Job No.: 1484
Checked: DER	Scale: NTS
File Name: 1484-SP.DWG	

 **Traffic and Civil Engineering Services**
PO Box 1237, 26 Main Street
Gray, ME 04039
207-657-6910

Drawing Name: General Notes – Lot 18
Project: TIDE MILL ROAD, PORTLAND

Figure No. 1

S:\Land Projects\1484\dwg\1484.SP.dwg, Layout1, 5/26/2006 9:03:14 AM, bvandamm, Gornil Palmer Consulting Engineers, Inc

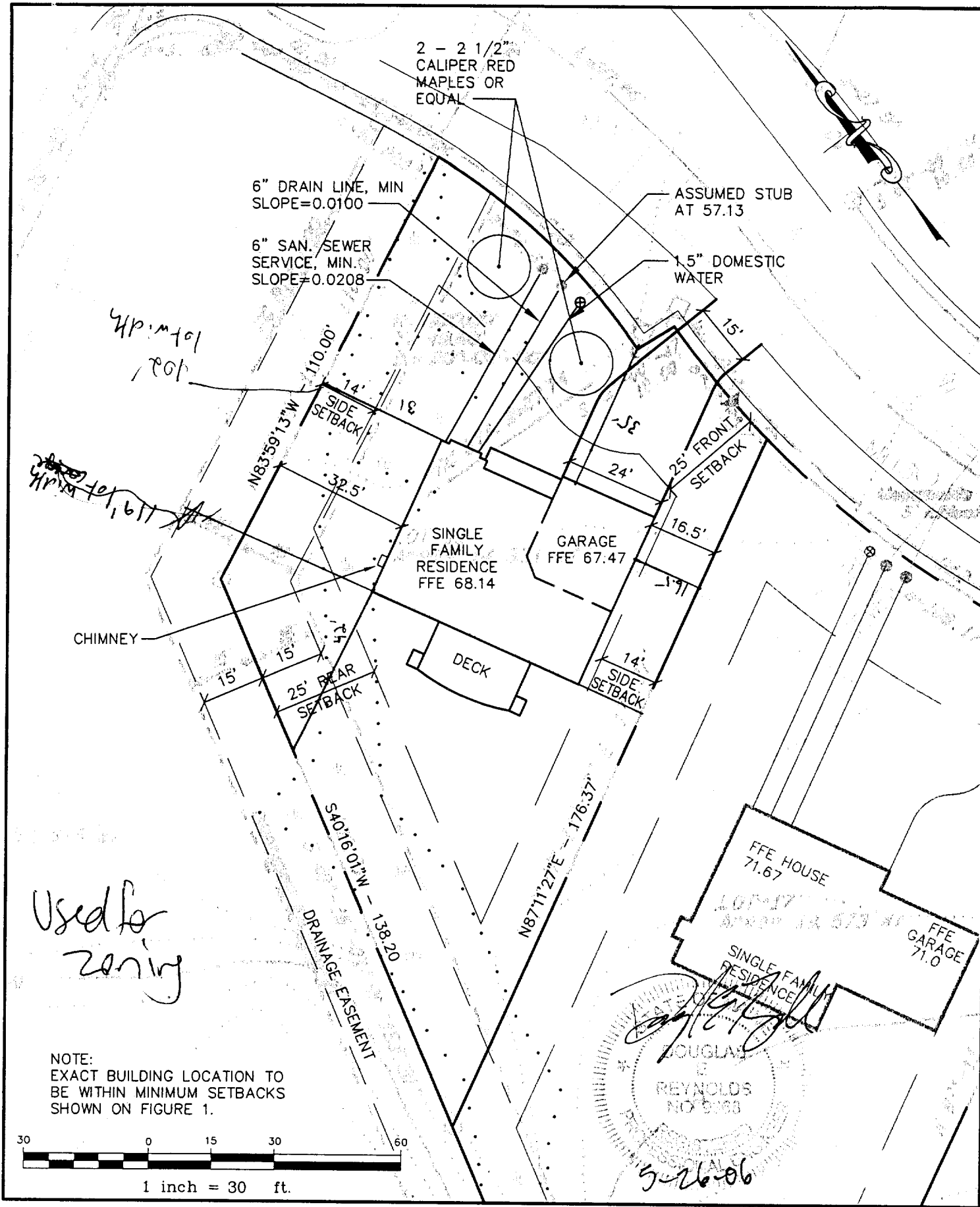

*HP 101
101*

*HP 101
101*

Used for zoning

NOTE:
EXACT BUILDING LOCATION TO
BE WITHIN MINIMUM SETBACKS
SHOWN ON FIGURE 1.

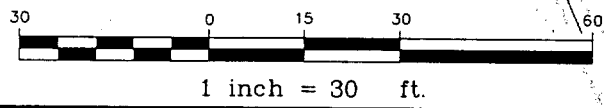

Handwritten signature

REYNOLDS
NO 9188

5-26-06

Design: DER	Date: JAN 2006
Draft: CAH	Job No.: 1484
Checked: DER	Scale: 1" = 30'
File Name: 1484-SP.DWG	

PO Box 1237, 26 Main Street
Gray, ME 04039
207-657-6910

Drawing Name:
Layout & Utilities Plan - Lot 18

Project:
TIDE MILL ROAD, PORTLAND

Figure No.
2

S:\Land Projects\1484\dwg\1484-SP.dwg, Layout1, 5/26/2006 9:03:29 AM, bvandamm, Gorill Palmer Consulting Engineers, Inc.

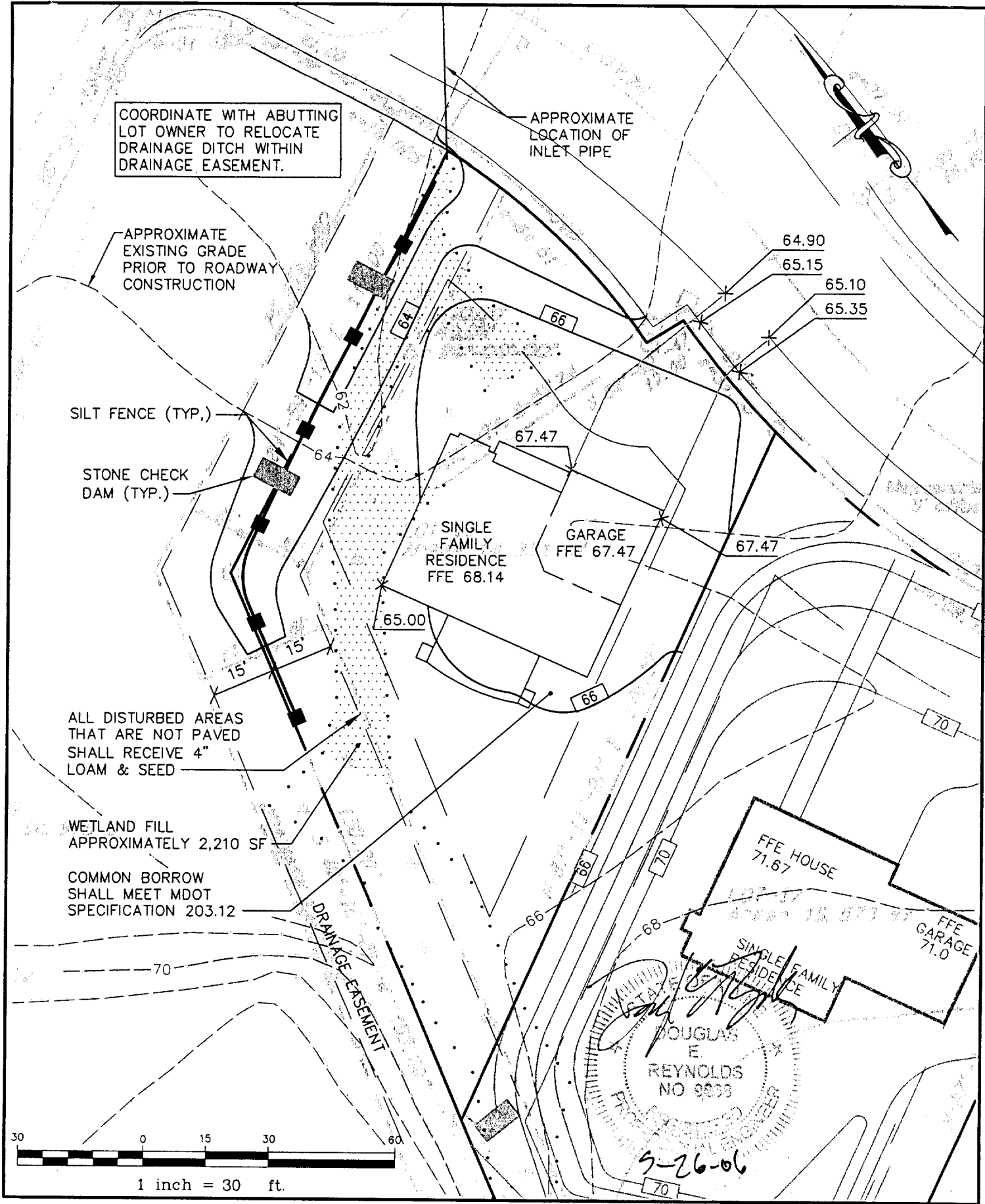

Design: DER	Date: JAN 2006
Draft: CAH	Job No.: 1484
Checked: DER	Scale: 1" = 30'
File Name: 1484-SP.dwg	

GP Gorill Palmer Consulting Engineers, Inc.
Traffic and Civil Engineering Services

PO Box 1237, 26 Main Street
Gray, ME 04039
207-657-6910

Drawing Name:
Grading & Drainage - Lot 18

Project:
TIDE MILL ROAD, PORTLAND

Figure No.
3

STAMPED PLANS 10

7827471

ONE AND TWO FAMILY	PLAN REVIEW	CHECKLIST
Soil type/Presumptive Load Value (Table R401.4.1)	Submitted Plan	Findings
Component	Revisions	Date
STRUCTURAL		
Footing Dimensions/Depth (Table R403.1 & R403.1(1), (Section R403.1 & R403.1.4.1)	10" x 20"	
Foundation Drainage, Fabric, Damp proofing (Section R405 & R406)	NEED FABRIC OK	
Ventilation/Access (Section R408.1 & R408.3) Crawls Space ONLY	Found 00m	
Anchor Bolts/Straps, spacing (Section R403.1.6)	OK 2 ANCHORS 6 FEET O.C.	
DOF SURCE 7	3 1/2 STEEL/CONCRETE	
Lally Column Type (Section R407)	3 1/2 x 14 LVL	
Girder & Header Spans (Table R 502.5(2))	NEED HEADER GIRDER INFO.	
Built-Up Wood Center Girder Dimension/Type	2'0"	
Sill/Band Joist Type & Dimensions	12" TJ, 5'60C.	
First Floor Joist Species Dimensions and Spacing (Table R502.3.1(1) & Table R502.3.1(2))	12" TJ, 5'60C.	
Second Floor Joist Species Dimensions and Spacing (Table R502.3.1(1) & Table R502.3.1(2))	12" TJ, 5'60C.	
Attic or additional Floor Joist Species Dimensions and Spacing (Table R802.4(1) and R802.4(2))	0	

OK

OK

OK

APR 26 2006

RECEIVED

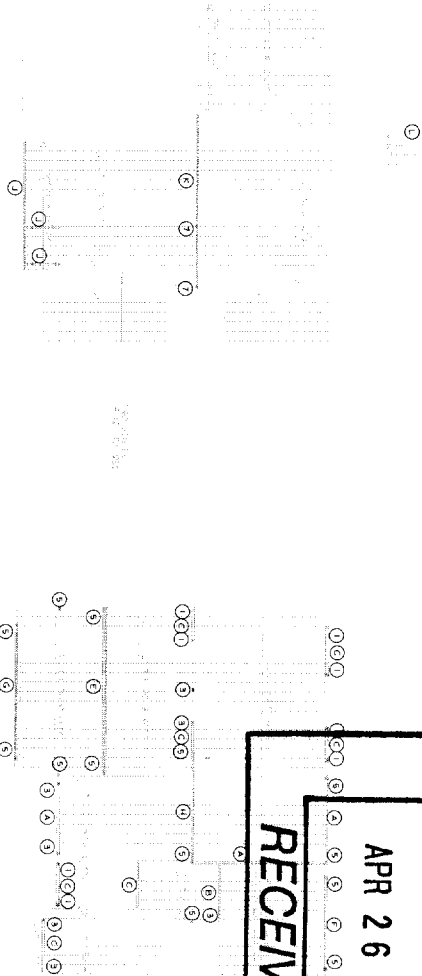

1ST FLOOR PLAN

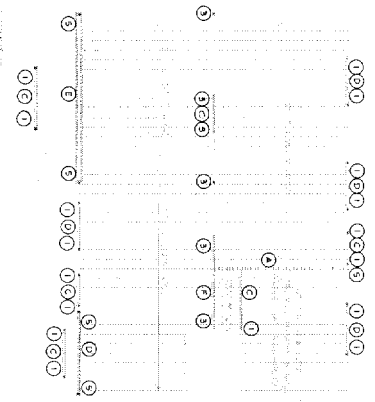

2ND FLOOR PLAN

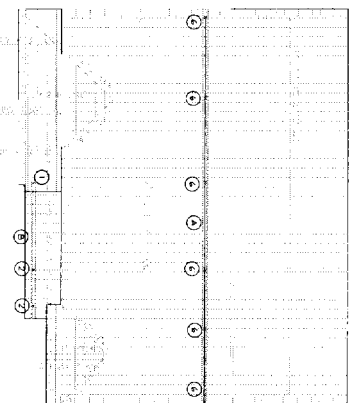

3RD FLOOR PLAN

- 1 DOUBLE 1-3/4" X 11-7/8" LVL
- 2 TRIPLE 2X10 PT
- 3 DOUBLE 2X12 RIGIDS
- 4 DOUBLE 1-3/4" X 11-7/8" LVL
- 5 DOUBLE 3-1/2" X 11" LVL
- 6 TRIPLE 1-3/4" X 11-7/8" LVL
- 7 SINGLE 5-1/2"X16"
- 8 WOOD 3X44 STEEL BEAM
- 9 DOUBLE 2X8 PT
- 10 TRIPLE 2X12 PT
- 11 3-1/2" X 11" LVL
- 12 TRIPLE STUD COLUMN
- 13 4X4 PT COLUMN
- 14 TRIPLE STUD COLUMN
- 15 3-1/2" X 8-1/2" PARALLEL COLUMN
- 16 5-1/2" X 8-1/2" PARALLEL COLUMN
- 17 3-1/2" CONCRETE FILLED WALL COLUMN

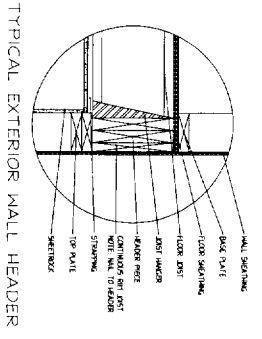

TYPICAL EXTERIOR WALL HEADER

PROJECT NUMBER	204 0000 00 0000 0000	TITLE	
DATE	03/17/06	SCALE	
DESIGNER	CH	CHECKED	
DRAWN BY	CH	DATE	

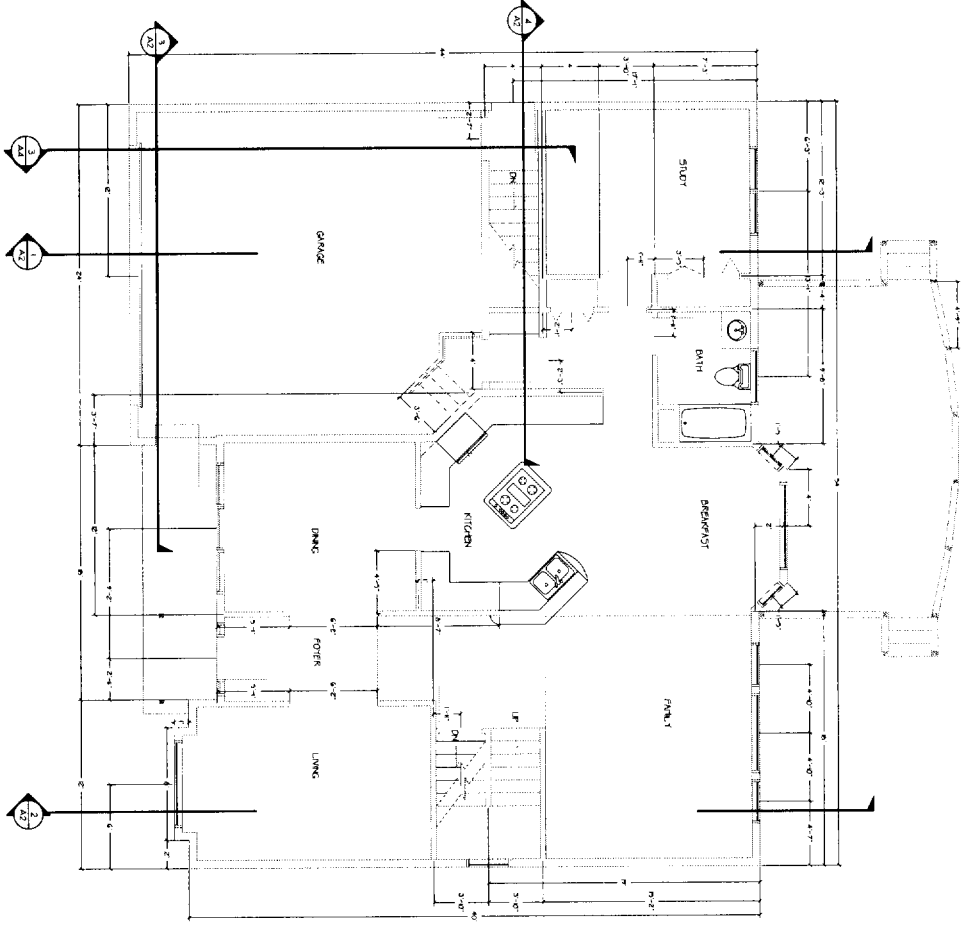

2 SECOND FLOOR PLAN

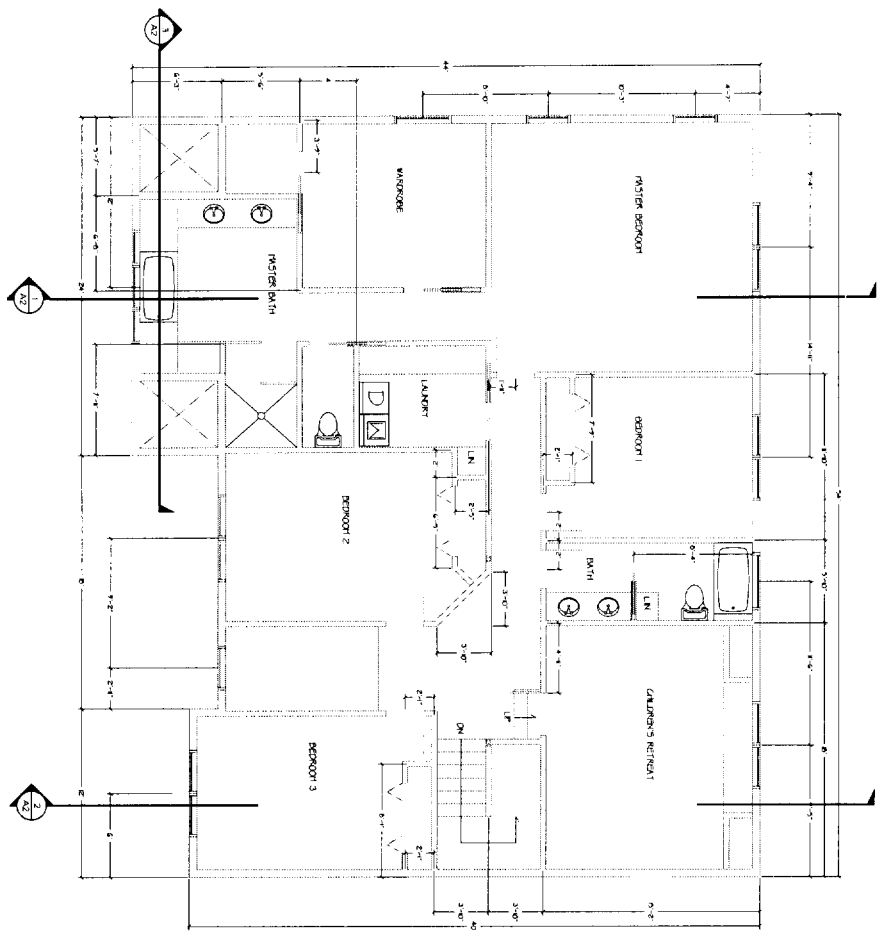

3 SECOND FLOOR PLAN

TITLE	
2ND FLOOR PLAN	Scale
3RD FLOOR PLAN	Scale
4TH FLOOR PLAN	Scale
5TH FLOOR PLAN	Scale
6TH FLOOR PLAN	Scale
7TH FLOOR PLAN	Scale
8TH FLOOR PLAN	Scale
9TH FLOOR PLAN	Scale
10TH FLOOR PLAN	Scale
11TH FLOOR PLAN	Scale
12TH FLOOR PLAN	Scale
13TH FLOOR PLAN	Scale
14TH FLOOR PLAN	Scale
15TH FLOOR PLAN	Scale
16TH FLOOR PLAN	Scale
17TH FLOOR PLAN	Scale
18TH FLOOR PLAN	Scale
19TH FLOOR PLAN	Scale
20TH FLOOR PLAN	Scale
21ST FLOOR PLAN	Scale
22ND FLOOR PLAN	Scale
23RD FLOOR PLAN	Scale
24TH FLOOR PLAN	Scale
25TH FLOOR PLAN	Scale
26TH FLOOR PLAN	Scale
27TH FLOOR PLAN	Scale
28TH FLOOR PLAN	Scale
29TH FLOOR PLAN	Scale
30TH FLOOR PLAN	Scale
31ST FLOOR PLAN	Scale
32ND FLOOR PLAN	Scale
33RD FLOOR PLAN	Scale
34TH FLOOR PLAN	Scale
35TH FLOOR PLAN	Scale
36TH FLOOR PLAN	Scale
37TH FLOOR PLAN	Scale
38TH FLOOR PLAN	Scale
39TH FLOOR PLAN	Scale
40TH FLOOR PLAN	Scale
41ST FLOOR PLAN	Scale
42ND FLOOR PLAN	Scale
43RD FLOOR PLAN	Scale
44TH FLOOR PLAN	Scale
45TH FLOOR PLAN	Scale
46TH FLOOR PLAN	Scale
47TH FLOOR PLAN	Scale
48TH FLOOR PLAN	Scale
49TH FLOOR PLAN	Scale
50TH FLOOR PLAN	Scale
51ST FLOOR PLAN	Scale
52ND FLOOR PLAN	Scale
53RD FLOOR PLAN	Scale
54TH FLOOR PLAN	Scale
55TH FLOOR PLAN	Scale
56TH FLOOR PLAN	Scale
57TH FLOOR PLAN	Scale
58TH FLOOR PLAN	Scale
59TH FLOOR PLAN	Scale
60TH FLOOR PLAN	Scale

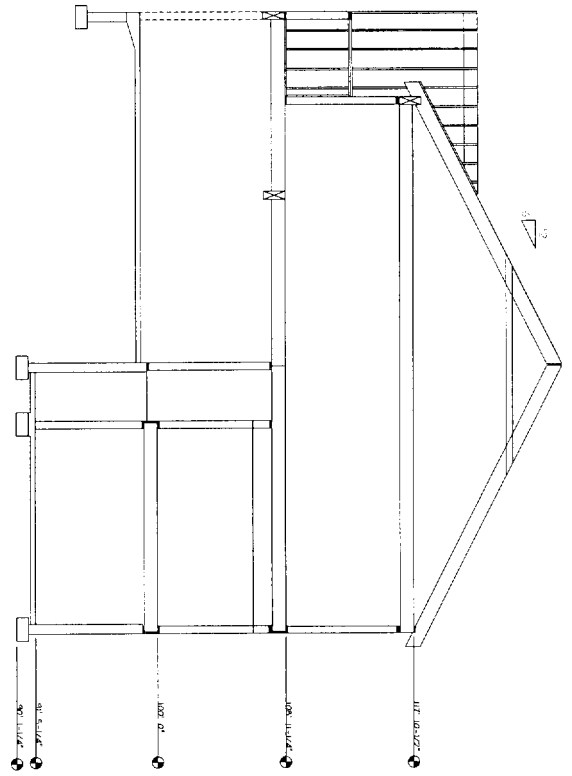

(

2)

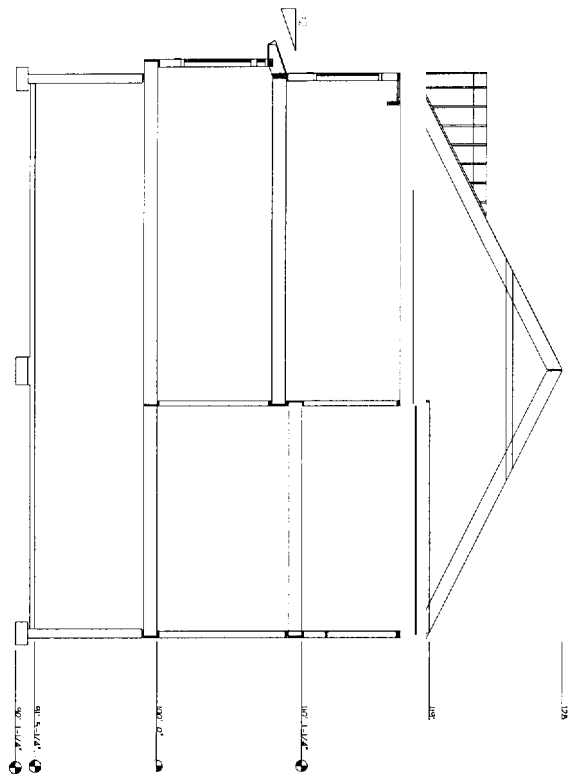

126

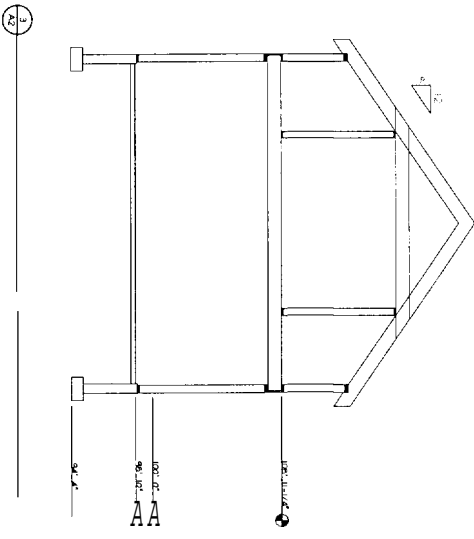

AA

4)

SECTION THROUGH BATTERY STAIR

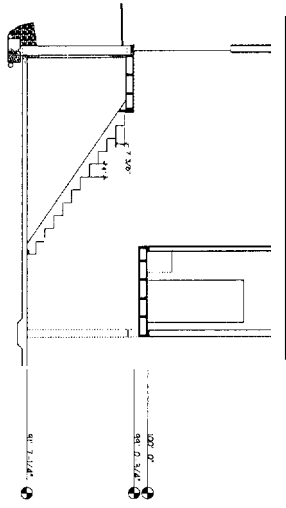

	TITLE	DATE	SCALE
	SECTION THROUGH BATTERY STAIR ARCHITECT: [Name] PROJECT: [Name] NO. [Number]		

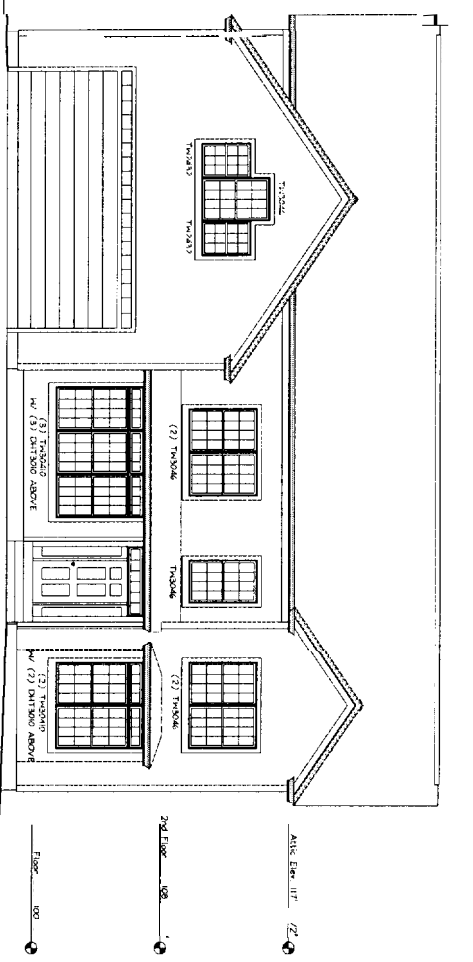
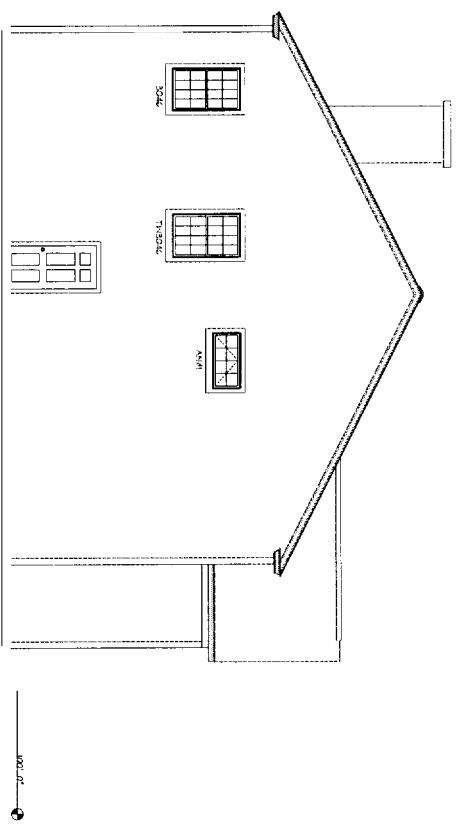
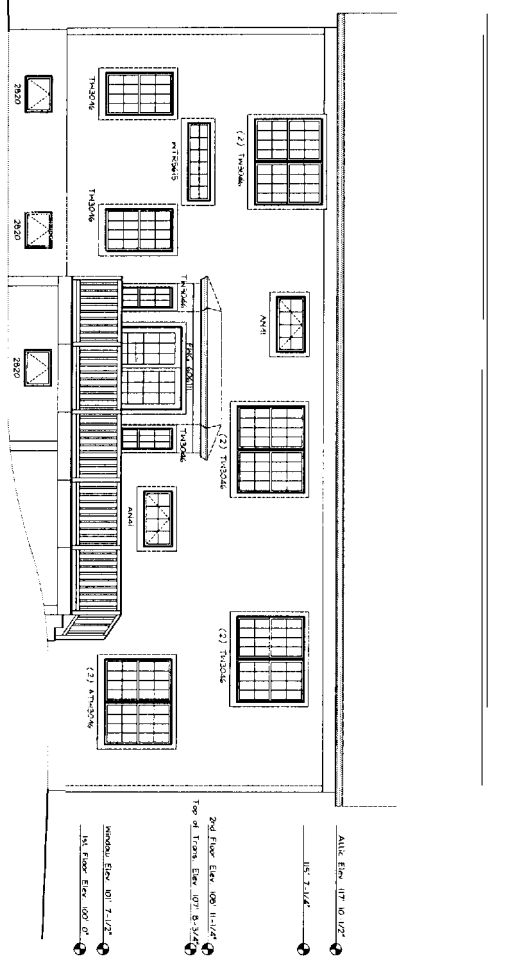
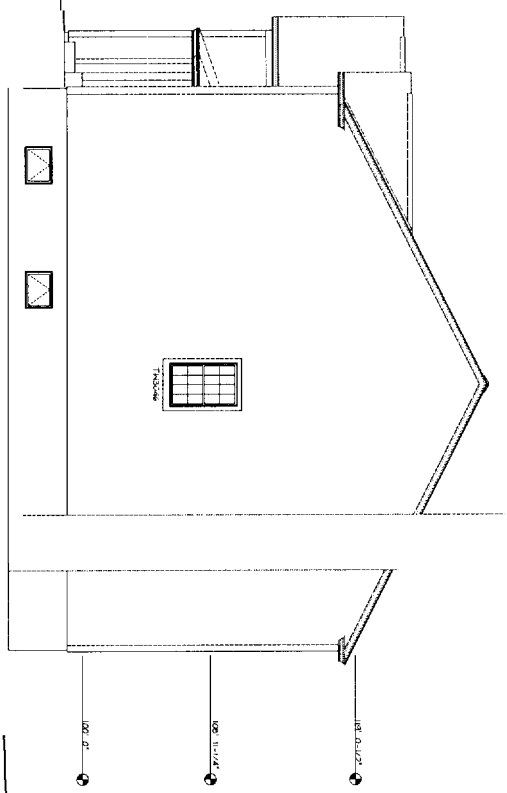

FIELD	VALUE
PROJECT	100' HALL STREET, SOUTHWEST CORNER OF 54TH AND 55TH STS., ALBANY, NY 12204
DATE	05/17/2019
DESIGNED BY	ANDERSON WINDOW DOORS
DRAWN BY	ANDERSON WINDOW DOORS
CHECKED BY	ANDERSON WINDOW DOORS
SCALE	1/8" = 1'-0"
TITLE	FRONT ELEVATION
NO.	100'
DATE	05/17/2019

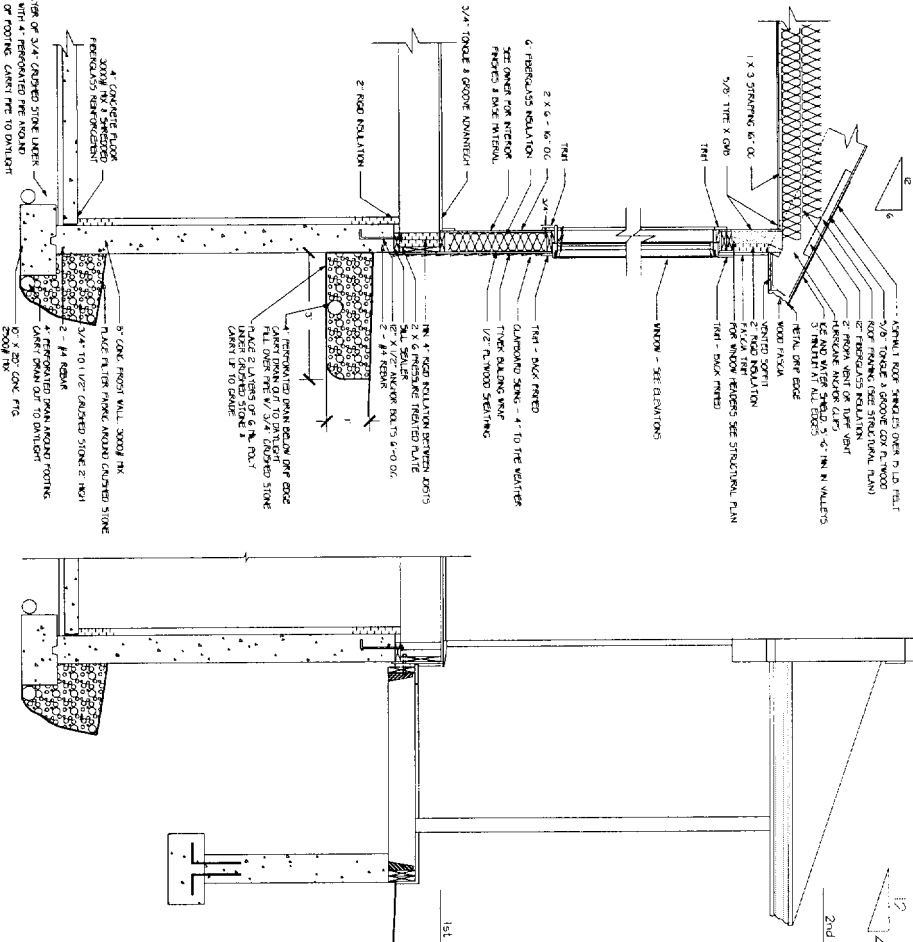

2nd Floor

1st Floor

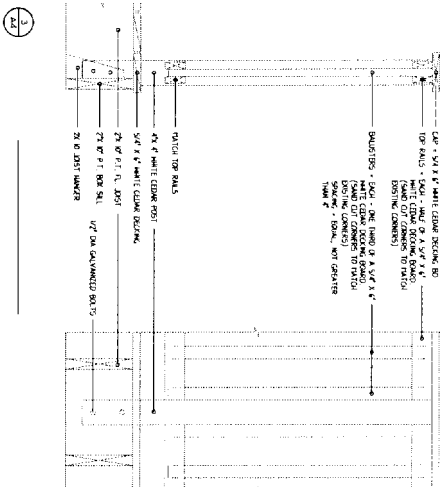

127
SCALE 3/4\"/>

128
SCALE 3/4\"/>

129
SCALE 3/4\"/>

TITLE		DATE	
127	128	129	130
131	132	133	134
135	136	137	138
139	140	141	142
143	144	145	146
147	148	149	150
151	152	153	154
155	156	157	158
159	160	161	162
163	164	165	166
167	168	169	170
171	172	173	174
175	176	177	178
179	180	181	182
183	184	185	186
187	188	189	190
191	192	193	194
195	196	197	198
199	200	201	202

SHEET