

TYPICAL CROSSWALK LAYOUT
NOT TO SCALE

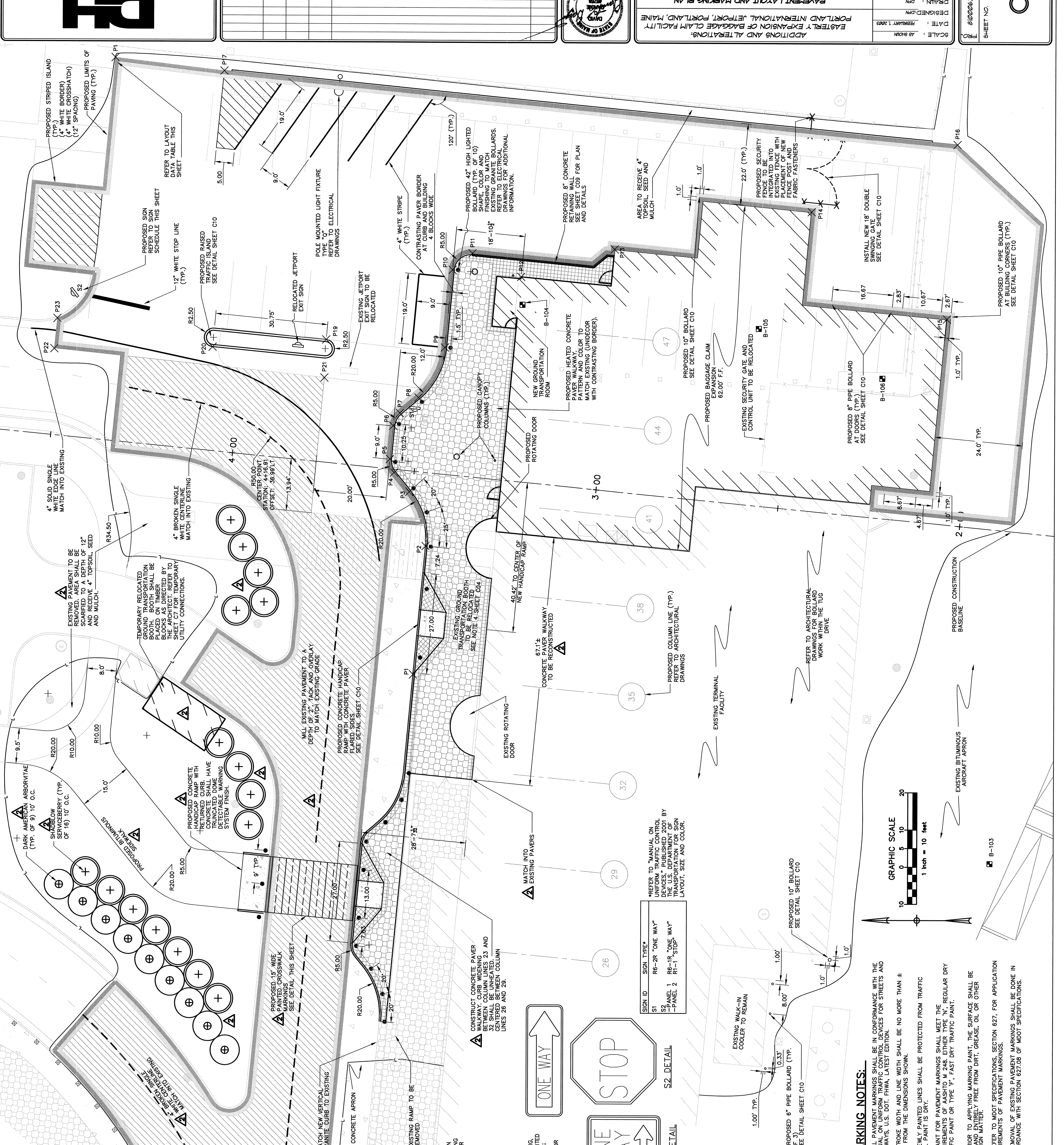

Dufresne-Henry
Portland, Maine
www.dufresnehenry.com
Tel: (207) 775-3211 • Fax: (207) 775-6414

REV#	DATE	DESCRIPTION	BY	CHECKED	DATE
1	4/22/04	CONCRETE DRAINAGE ISSUED FOR CONSTRUCTION	PN	PN	
2	3/27/04	APPENDIX NO. 2	PN	PN	
3	FEB. 25, 2004				

PHILIP J. DOUGHTY ASSOC. ARCHITECTS
202 U.S. ROUTE ONE, FAIRMOUTH, MAINE 04105 • 207.781.9346

STATE OF MAINE
REGISTERED PROFESSIONAL ARCHITECT
PHILIP J. DOUGHTY, ARCHITECT

PHILIP J. DOUGHTY ASSOC. ARCHITECTS
EASTERN EXPANSION OF BAGGAGE CLAIM FACILITY
PORTLAND INTERNATIONAL JETPORT, PORTLAND, MAINE

ADDITIONS AND ALTERATIONS
PAVEMENT LAYOUT AND MARKING PLAN
9 INCHES
AND DETAILS

DATE: FEBRUARY 1, 2004
DESIGNED BY: PHILIP J. DOUGHTY
CHECKED BY: PHILIP J. DOUGHTY
APPROVED BY: PHILIP J. DOUGHTY

SCALE: AS SHOWN
SHEET NO. 80
PROJECT NO. 020006

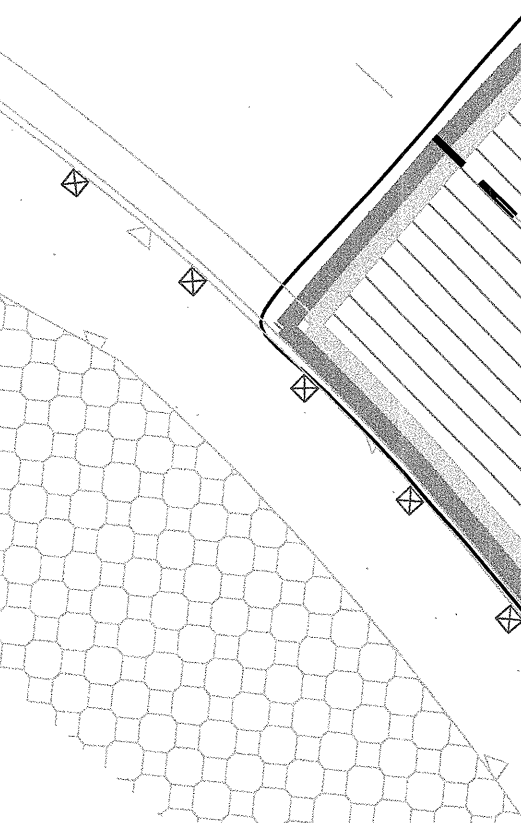

TRAFFIC SIGN POST
NOT TO SCALE

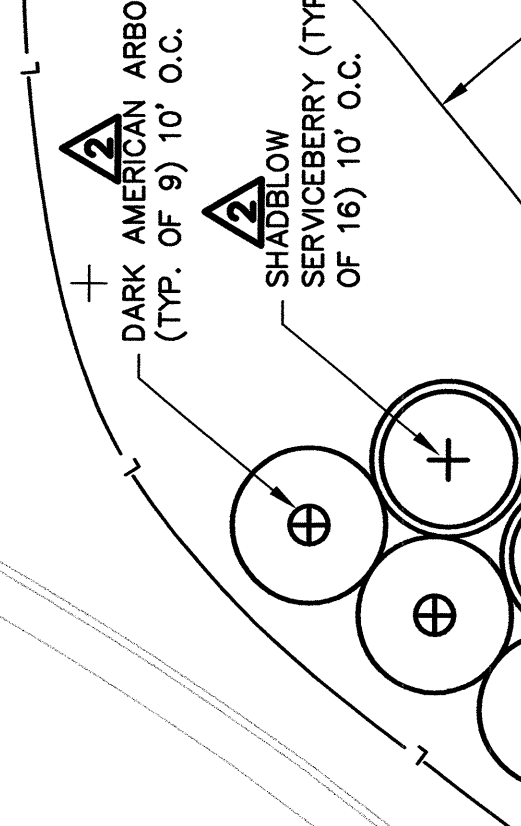

TRAFFIC SIGN PANEL
NOT TO SCALE

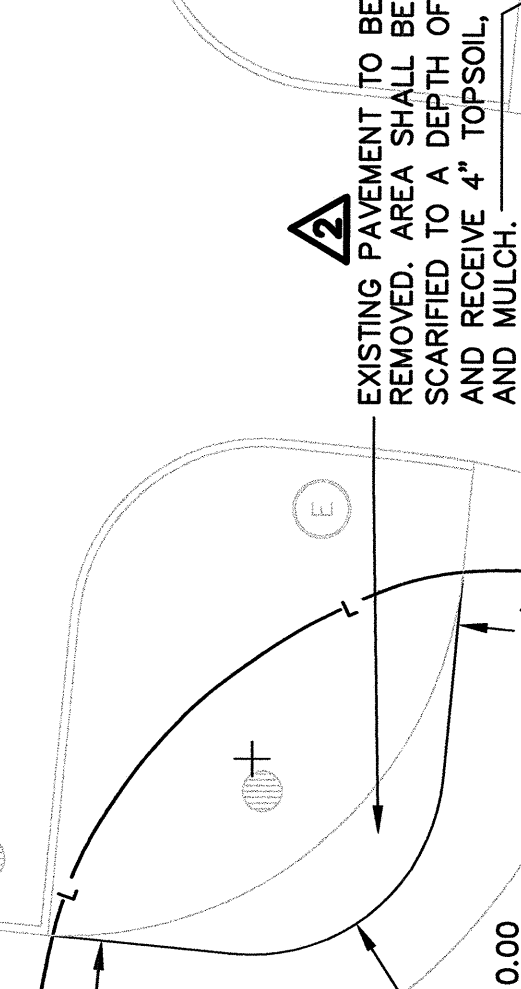

SIGN ID TYPE:
S1 R6-2R "ONE WAY"
S2 R6-1R "ONE WAY"
R1-1 "STOP"

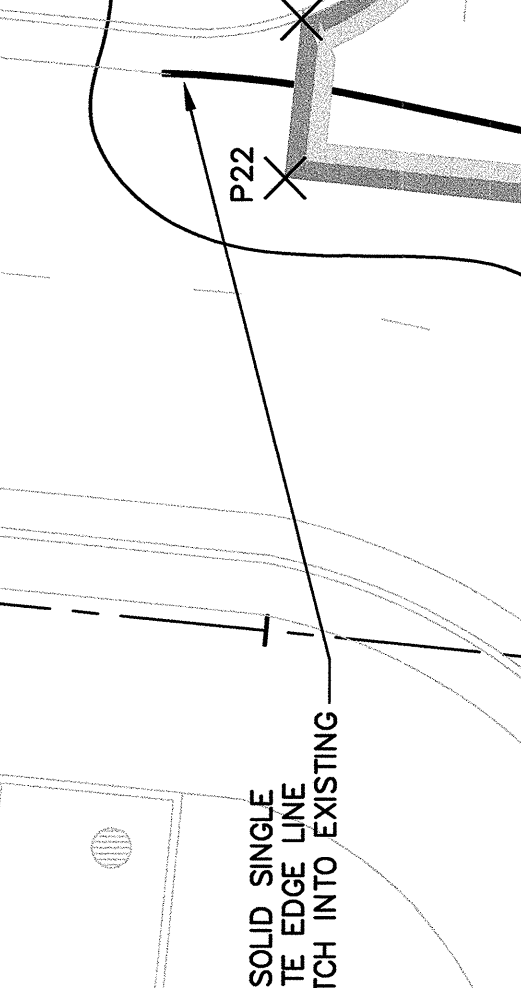

MARKING NOTES:
1. ALL PAVEMENT MARKINGS SHALL BE IN CONFORMANCE WITH THE MANUAL ON UNIFORM TRAFFIC CONTROL DEVICES FOR STREETS AND HIGHWAYS, U.S. DOT, FHWA, LATEST EDITION.
2. STROKE WIDTH AND LINE WIDTH SHALL BE NO MORE THAN +/- 1/4" FROM THE DIMENSIONS SHOWN.
3. NEWLY PAINTED LINES SHALL BE PROTECTED FROM TRAFFIC UNTIL PAINT IS DRY.
4. PAINT FOR PAVEMENT MARKINGS SHALL MEET THE REQUIREMENTS OF AASHTO M. 248, EITHER TYPE 'N', REGULAR DRY TRAFFIC PAINT OR TYPE 'P', PAST DRY TRAFFIC PAINT.
5. PRIOR TO APPLYING MARKING PAINT, THE SURFACE SHALL BE DRY, CLEAN, FREE FROM DIRT, GREASE, OIL OR OTHER FOREIGN MATTER.
6. REFER TO MOST SPECIFICATIONS, SECTION 627, FOR APPLICATION REQUIREMENTS OF PAVEMENT MARKINGS.
7. REMOVAL OF EXISTING PAVEMENT MARKINGS SHALL BE DONE IN ACCORDANCE WITH SECTION 627.06 OF MOST SPECIFICATIONS.

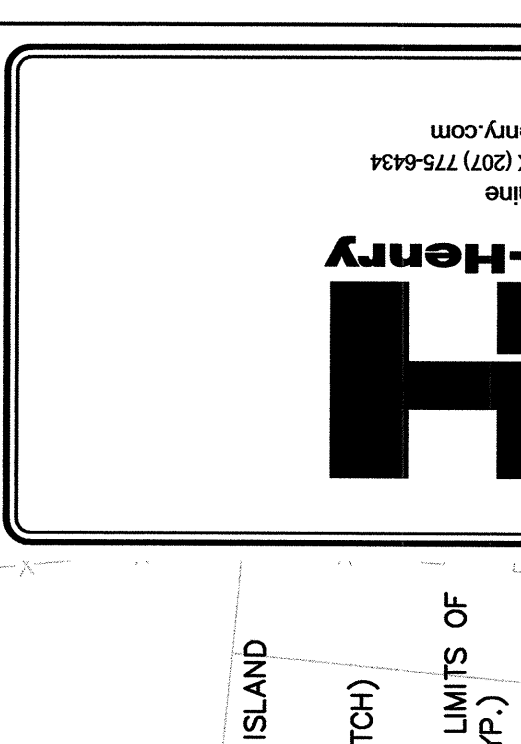

GRAPHIC SCALE
1 inch = 10 feet

THIS DRAWING IS AN INSTRUMENT OF SERVICE AND SHALL REMAIN THE PROPERTY OF PHILIP J. DOUGHTY ASSOCIATES, ARCHITECTS. IT IS TO BE USED ONLY FOR THE PROJECT AND SITE SPECIFICALLY IDENTIFIED HEREON. NO PART OF THIS DRAWING IS TO BE REPRODUCED OR TRANSMITTED IN ANY FORM OR BY ANY MEANS, ELECTRONIC OR MECHANICAL, INCLUDING PHOTOCOPYING, RECORDING, OR BY ANY INFORMATION STORAGE AND RETRIEVAL SYSTEM, WITHOUT THE WRITTEN PERMISSION OF PHILIP J. DOUGHTY ASSOCIATES, ARCHITECTS.