

1/16"=1'-0" 5 0 10 20 30 40ft 1/8"=1'-0" 5 0 5 10 15 20ft 1/4"=1'-0" 2 0 2 4 6 8 10ft 1/2"=1'-0" 1 0 1 2 3 4 5ft 3/4"=1'-0" 1 0 1 1 2 3ft 1"=1'-0" 1 0 1 2ft 1 1/2"=1'-0" 0 1 2ft 3"=1'-0" 0 1ft

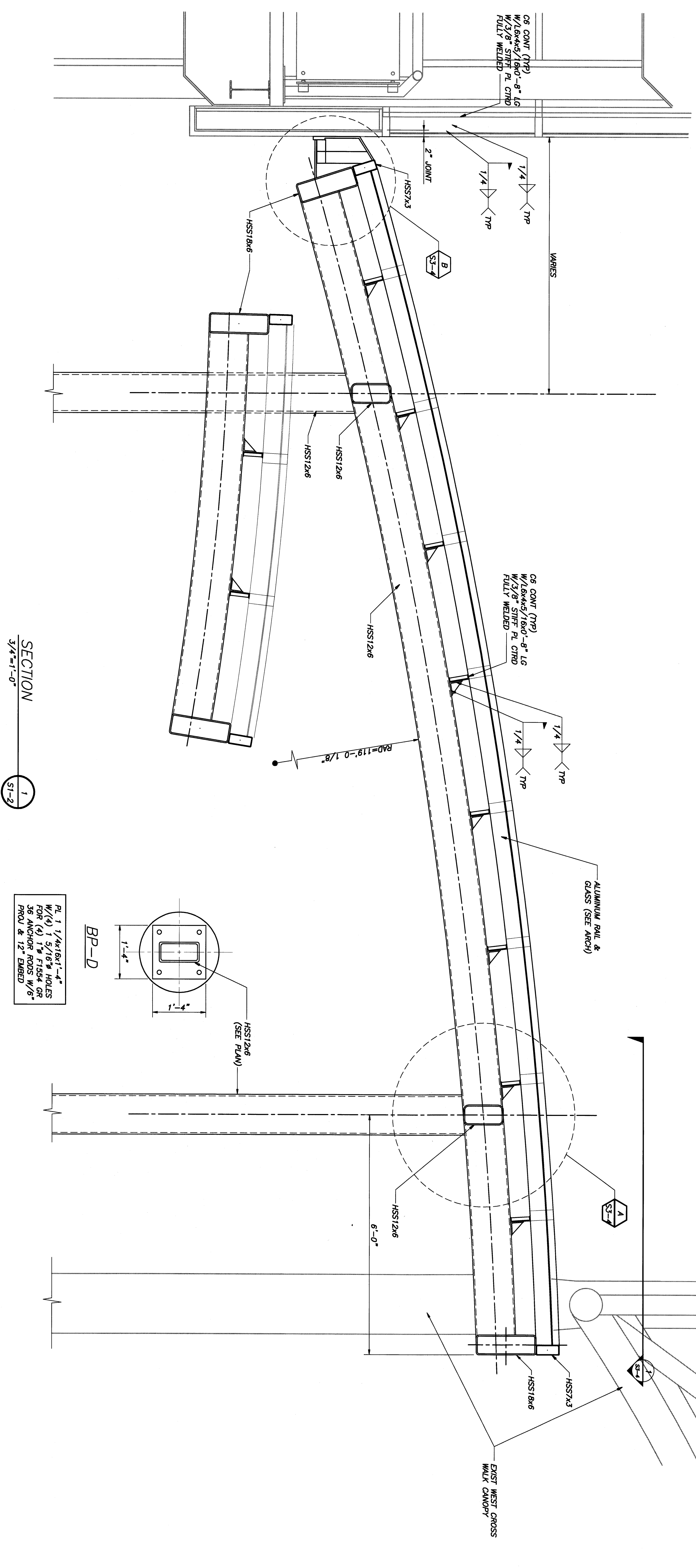

SECTION 1
3/4"=1'-0"

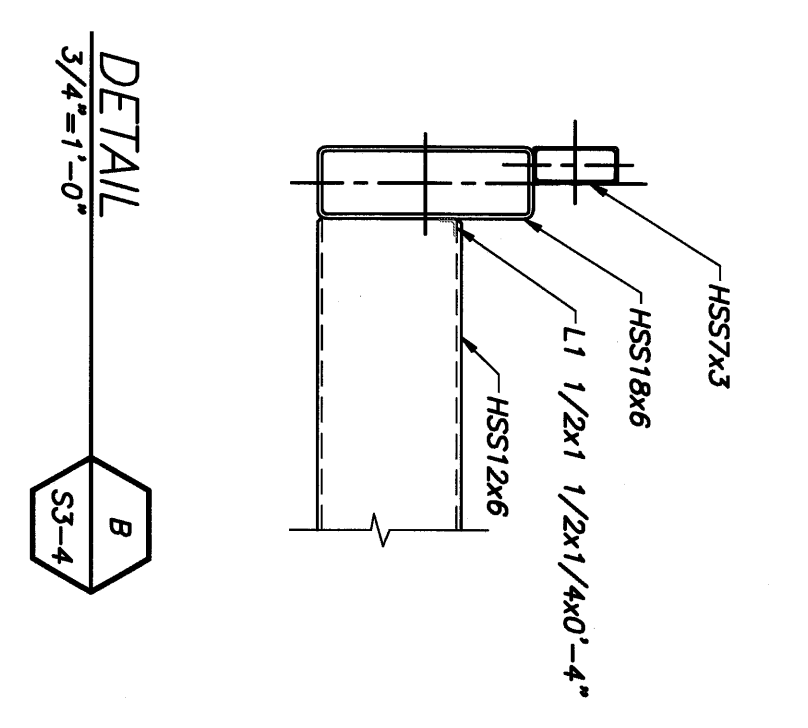
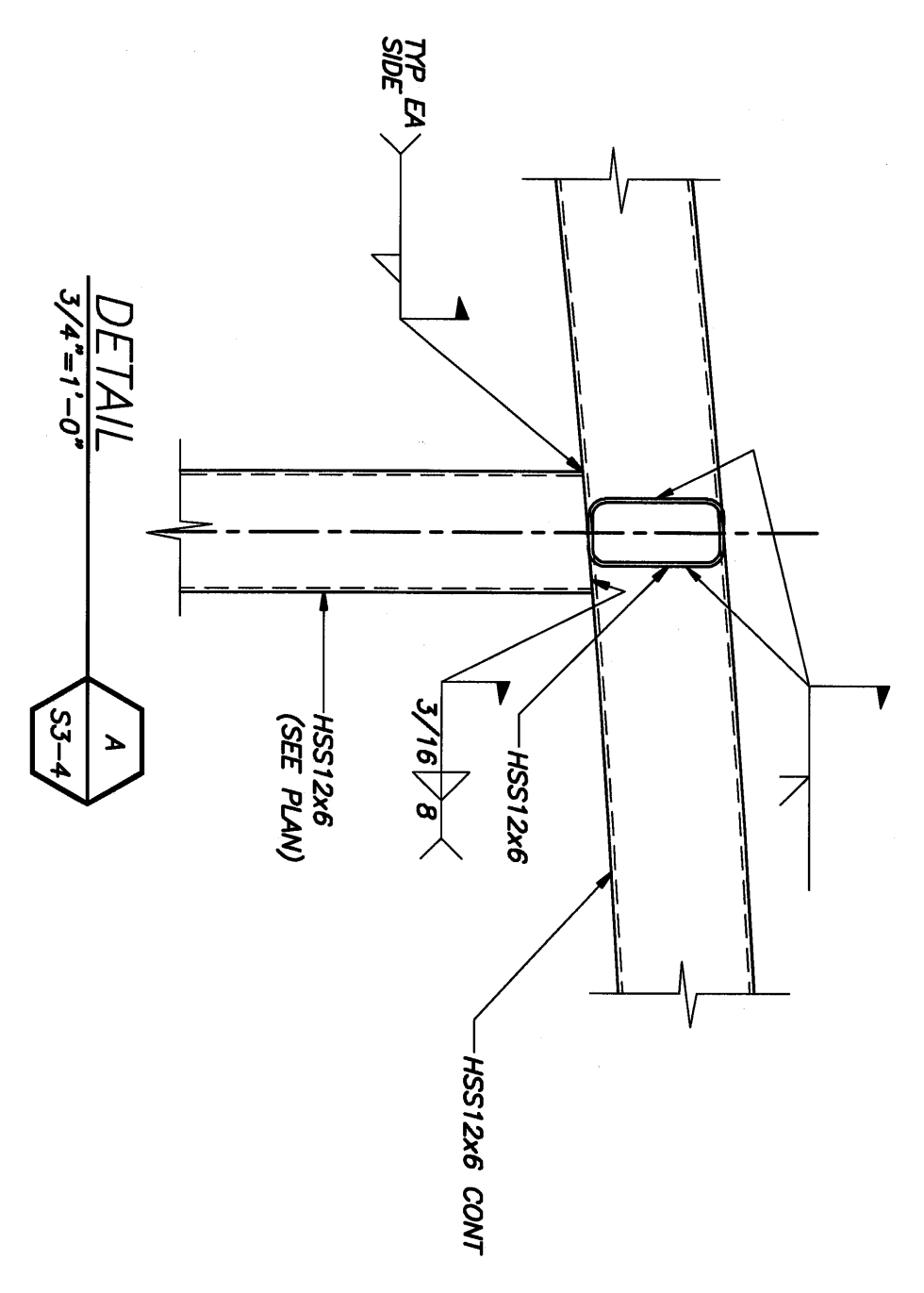
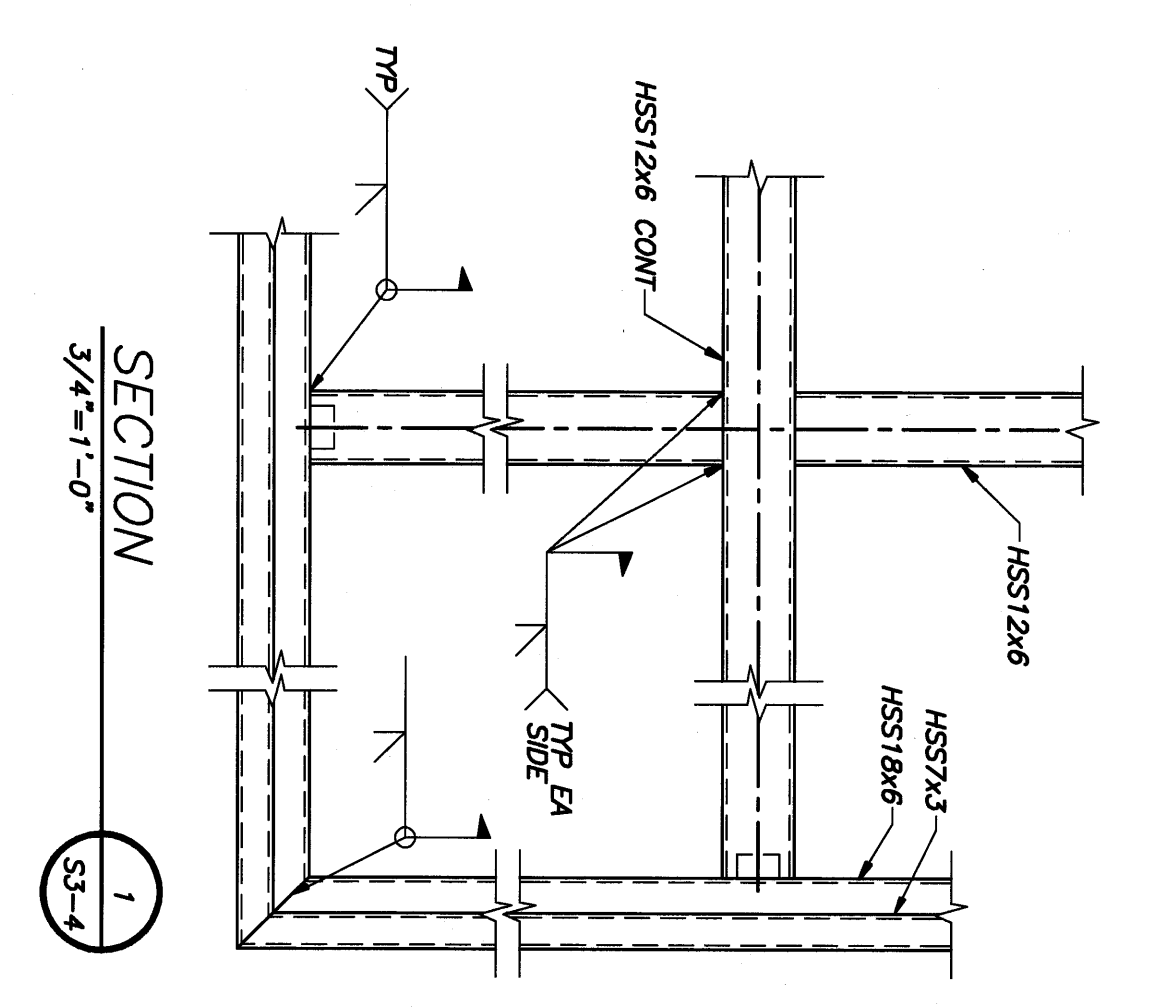
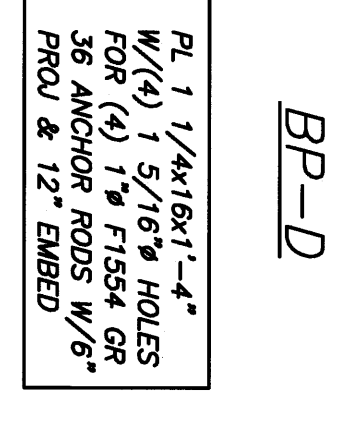

NOTED

CANOPY SECTIONS & DETAILS

NO. DATE REVISION

TITLE

DATE

SCALE

1001 WESTBROOK ST.,
PORTLAND, MAINE

PHASE II
PARKING GARAGE

PORTLAND
INTERNATIONAL
JETPORT

PMTI

CITY OF PORTLAND
PORTLAND, MAINE

DEPARTMENT OF
WATERFRONT AND
TRANSPORTATION

Confirmed-Set,
for Field Use

BECKER
STRUCTURAL ENGINEERS, INC.
155 Massachusetts Ave.
Boston, MA 02115
617-257-6408
Fax 617-257-1990

**DOMENECH
HICKS &
KROCKMALLIN
ARCHITECTS**

155 Massachusetts Ave.
Boston, MA 02115
617-257-6408
Fax 617-257-1990

Job No. 1493
Date 2/20/2008

Checked by TMM
Drawing No. S3-4

Drawn by
Title Number

UNIVERSITY OF MAINE
SEALED
NO. 8348
JAN 22 2008
MAINE STATE ENGINEERING BOARD

If this sheet is less than 30"x42" in size, it has been reduced. Graphic scales must be adjusted accordingly.