

DISPLAY THIS CARD ON PRINCIPAL FRONTAGE OF WORK CITY OF PORTLAND

BUILDING INSPECTION

PERMIT

Permit Number: 080395

Please Read Application And Notes, If Any, Attached

This is to certify that DELTA AIR LINES INC D 852 CORP TAX/Arene Cor cting
has permission to Hood System over cooking equipment
AT 1001 WESTBROOK ST 208 A001002

provided that the person or persons, firm or corporation accepting this permit shall comply with all of the provisions of the Statutes of Maine and of the Ordinances of the City of Portland regulating the construction, maintenance and use of buildings and structures, and of the application on file in this department.

Apply to Public Works for street line and grade if nature of work requires such information.

Notification of inspection must be given and when permission is procured before this building or part thereof is lated or closed-in. **24 HOUR NOTICE IS REQUIRED.**

A certificate of occupancy must be procured by owner before this building or part thereof is occupied.

OTHER REQUIRED APPROVALS

Fire Dept. Gregg Cross
Health Dept. _____
Appeal Board _____
Other _____

Department Name

Director - Building & Inspection Services

PENALTY FOR REMOVING THIS CARD

BUILDING PERMIT INSPECTION PROCEDURES

Please call 874-8703 or 874-8693 (ONLY)

to schedule your inspections as agreed upon

Permits expire in 6 months, if the project is not started or ceases for 6 months.

The Owner or their designee is required to notify the inspections office for the following inspections and provide adequate notice. Notice must be called in 48-72 hours in advance in order to schedule an inspection:

By initializing at each inspection time, you are agreeing that you understand the inspection procedure and additional fees from a "Stop Work Order" and "Stop Work Order Release" will be incurred if the procedure is not followed as stated below.

A Pre-construction Meeting will take place upon receipt of your building permit.

 X **Framing/Rough Plumbing/Electrical: Prior to Any Insulating or drywalling**

Certificate of Occupancy is not required for certain projects. Your inspector can advise you if your project requires a Certificate of Occupancy. All projects DO require a final inspection.

If any of the inspections do not occur, the project cannot go on to the next phase, REGARDLESS OF THE NOTICE OR CIRCUMSTANCES.

CERIFICATE OF OCCUPANICES MUST BE ISSUED AND PAID FOR, BEFORE THE SPACE MAY BE OCCUPIED.



Signature of Applicant/Designee

 5/9/08
Date



Signature of Inspections Official

 5/7/08
Date

City of Portland, Maine - Building or Use Permit Application

389 Congress Street, 04101 Tel: (207) 874-8703, Fax: (207) 874-8716

Permit No: 08-0395	Issue Date:	CBL: 208 A001002
-----------------------	-------------	---------------------

Location of Construction: 1001 WESTBROOK ST	Owner Name: DELTA AIR LINES INC DEPT 85	Owner Address: PO BOX 45852	Phone:
Business Name:	Contractor Name: Arene Contracting, LLC	Contractor Address: 3070 Windward Plz, Suite 265 Portlan	Phone
Lessee/Buyer's Name	Phone:	Permit Type: Hood Systems, Commerical	Zone: A/B

Past Use: Portland International Jetport - Restaurants- Connected w/ permit# 08-0006	Proposed Use: Portland International Jetport - Restaurants- Connected w/ permit# 08-0006 - Hood System over cooking equipment	Permit Fee:	Cost of Work: \$13,117.00	CEO District: 3
		FIRE DEPT: <input checked="" type="checkbox"/> Approved <input type="checkbox"/> Denied NFPA 96	INSPECTION: Use Group: A2 Type: Tyre Hood DML-2003	

Proposed Project Description:
Hood System over cooking equipment

Signature: *Craig Cross* Signature:

PEDESTRIAN ACTIVITIES DISTRICT (P.A.D.)

Action: Approved Approved w/Conditions Denied

Signature: Date:

Permit Taken By: Idobson	Date Applied For: 04/22/2008	Zoning Approval	
-----------------------------	---------------------------------	------------------------	--

<p>1. This permit application does not preclude the Applicant(s) from meeting applicable State and Federal Rules.</p> <p>2. Building permits do not include plumbing, septic or electrical work.</p> <p>3. Building permits are void if work is not started within six (6) months of the date of issuance. False information may invalidate a building permit and stop all work..</p>	<p>Special Zone or Reviews</p> <p><input type="checkbox"/> Shoreland</p> <p><input type="checkbox"/> Wetland</p> <p><input type="checkbox"/> Flood Zone</p> <p><input type="checkbox"/> Subdivision</p> <p><input type="checkbox"/> Site Plan</p> <p>Maj <input type="checkbox"/> Minor <input type="checkbox"/> MM <input type="checkbox"/></p> <p>Date: <i>4/23/09</i></p>	<p>Zoning Appeal</p> <p><input type="checkbox"/> Variance</p> <p><input type="checkbox"/> Miscellaneous</p> <p><input type="checkbox"/> Conditional Use</p> <p><input type="checkbox"/> Interpretation</p> <p><input type="checkbox"/> Approved</p> <p><input type="checkbox"/> Denied</p> <p>Date:</p>	<p>Historic Preservation</p> <p><input checked="" type="checkbox"/> Not in District or Landmark</p> <p><input type="checkbox"/> Does Not Require Review</p> <p><input type="checkbox"/> Requires Review</p> <p><input type="checkbox"/> Approved</p> <p><input type="checkbox"/> Approved w/Conditions</p> <p><input type="checkbox"/> Denied</p> <p>Date:</p>
---	---	--	---

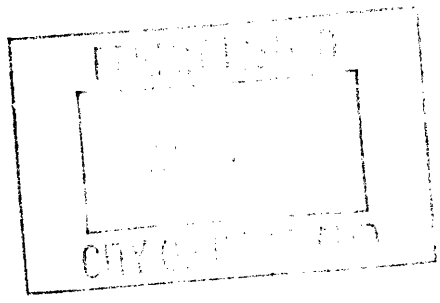

CERTIFICATION

I hereby certify that I am the owner of record of the named property, or that the proposed work is authorized by the owner of record and that I have been authorized by the owner to make this application as his authorized agent and I agree to conform to all applicable laws of this jurisdiction. In addition, if a permit for work described in the application is issued, I certify that the code official's authorized representative shall have the authority to enter all areas covered by such permit at any reasonable hour to enforce the provision of the code(s) applicable to such permit.

SIGNATURE OF APPLICANT	ADDRESS	DATE	PHONE
RESPONSIBLE PERSON IN CHARGE OF WORK, TITLE		DATE	PHONE

City of Portland, Maine - Building or Use Permit

389 Congress Street, 04101 Tel: (207) 874-8703, Fax: (207) 874-8716

Permit No: 08-0395	Date Applied For: 04/22/2008	CBL: 208 A001002
------------------------------	--	----------------------------

Location of Construction: 1001 WESTBROOK ST	Owner Name: DELTA AIR LINES INC DEPT 852	Owner Address: PO BOX 45852	Phone:
Business Name:	Contractor Name: Arene Contracting, LLC	Contractor Address: 3070 Windward Plz, Suite 265 Portlan	Phone
Lessee/Buyer's Name	Phone:	Permit Type: Hood Systems, Commerical	

Proposed Use: Portland International Jetport - Restaurants- Connected w/ permit# 08-0006 - Hood System over cooking equipment	Proposed Project Description: Hood System over cooking equipment
---	--

Dept: Zoning	Status: Approved	Reviewer: Marge Schmuckal	Approval Date: 04/23/2008	Note:	Ok to Issue: <input checked="" type="checkbox"/>
Dept: Building	Status: Approved with Conditions	Reviewer: Jeanine Bourke	Approval Date: 05/07/2008	Note: 1) The Hood shall be installed per IMC 2003 and NFPA 96	Ok to Issue: <input checked="" type="checkbox"/>
Dept: Fire	Status: Approved with Conditions	Reviewer: Capt Greg Cass	Approval Date: 04/28/2008	Note: 1) Install shall comply with NFPA 96. A compliance letter is required	Ok to Issue: <input checked="" type="checkbox"/>

Comments: 5/7/2008-jmb: Plans are with permit # 08-0006 5/4/2008-jmb: Spoke w/Devan at Arene for details on hood clearance reductions designs to walls and ceilings
--

Permit # 080006

Lannire



NCASFA

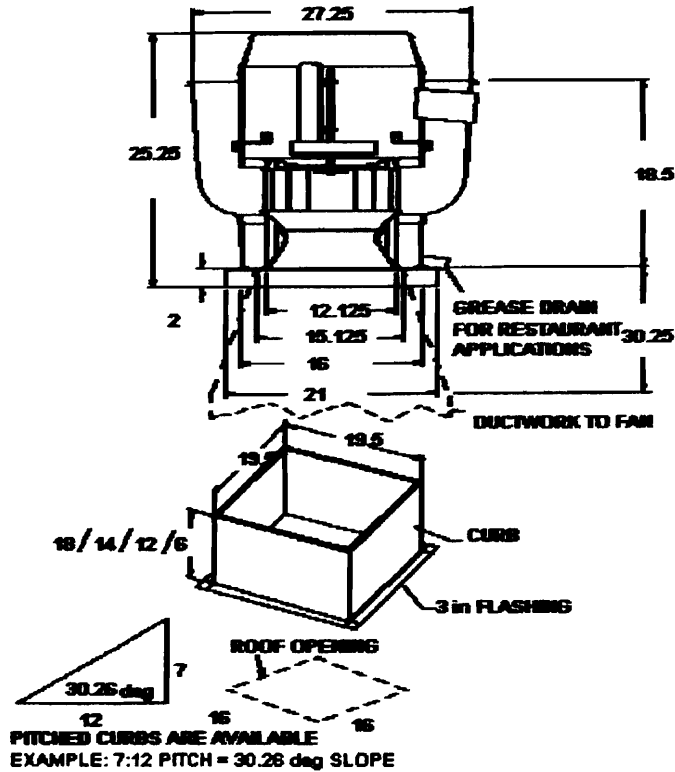

All dimensions in inches.
 Rated for restaurant and general ventilation applications.
 Curb for restaurant applications to be 22" high and vented.
 Do not use backdraft damper on kitchen applications.

Back

Scan & Email to

ddean.aarene contracting@gmail.com



General Building Permit Application

If you or the property owner owes real estate or personal property taxes or user charges on any property within the City, payment arrangements must be made before permits of any kind are accepted.

Location/Address of Construction: <u>1001 Westbrook St.</u>		
Total Square Footage of Proposed Structure/Area		Square Footage of Lot
Tax Assessor's Chart, Block & Lot Chart# <u>208</u> Block# <u>A</u> Lot# <u>1</u>	Applicant * <u>must</u> be owner, Lessee or Buyer* Name <u>City of Portland</u> Address <u>Jetport</u> City, State & Zip _____	Telephone: _____
Lessee/DBA (If Applicable) <u>SHIPYARD ARTS.</u>	Owner (if different from Applicant) Name _____ Address _____ City, State & Zip _____	Cost Of Work: \$ <u>13,117.00</u> C of O Fee: \$ _____ Total Fee: \$ <u>160</u>
Current legal use (i.e. single family) <u>Jetport Restaurants</u> If vacant, what was the previous use? _____ Proposed Specific use: _____ Is property part of a subdivision? _____ If yes, please name _____ Project description: <u>Hood system over cooking equipment</u>		
Contractor's name: <u>AMANN CONTRACTING</u> Address: <u>3070 Windward Plaza</u> City, State & Zip <u>ALPHARETTA, Georgia 30005</u> Telephone: <u>678566-0609</u> Who should we contact when the permit is ready: <u>DAVID FORSTER</u> Telephone: <u>6787359023</u> Mailing address: <u>FORREST PARK APT 6F4 PORTLAND ME</u>		

Please submit all of the information outlined on the applicable Checklist. Failure to do so will result in the automatic denial of your permit.

In order to be sure the City fully understands the full scope of the project, the Planning and Development Department may request additional information prior to the issuance of a permit. For further information or to download copies of this form and other applications visit the Inspections Division on-line at www.portlandmaine.gov, or stop by the Inspections Division office, room 315 City Hall or call 874-8703.

I hereby certify that I am the Owner of record of the named property, or that the owner of record authorizes the proposed work and that I have been authorized by the owner to make this application as his/her authorized agent. I agree to conform to all applicable laws of this jurisdiction. In addition, if a permit for work described in this application is issued, I certify that the Code Official's authorized representative shall have the authority to enter all areas covered by this permit at any reasonable hour to enforce the provisions of the codes applicable to this permit.

Signature <u>[Handwritten Signature]</u>	Date: <u>4/22/08</u>
--	----------------------

This is not a permit; you may not commence ANY work until the permit is issue



Strengthening a Remarkable City. Building a Community for Life • www.portlandmaine.gov

Lee Urban - Director of Planning and Development
Jeanie Bourke - Inspection Division Services Director

PRE-SECURITY

Kitchen Exhaust System Checklist and code Provisions

Dear Applicant,

The following is a checklist to assist you in filing for a permit for a Kitchen Exhaust system. The applicable Mechanical Code provisions have also been attached. Please complete this and submit job specific construction documents that demonstrate compliance with the attached information.

Type of System:

Type I X Type II _____

Type I systems are systems that vent fryers, grills, broilers, ovens or woks.

Type II systems are systems that vent steamers and other non grease producing appliances.

Type of Materials:

Is the hood Stainless steel or other type of steel? Stainless If Other, what Type? _____

Is the duct work Stainless steel or other type of steel? NO If Other, what type? Black Iron

Thickness of the steel for the hood 18 gauge

Thickness of the duct for the hood 16 gauge

Type of Hood and Duct Supports

Hood: 1/2 Dia All Thread Rods

Type of seams and Joints Welded liquid Tight

Cost Hood \$8880.00
Duct, Fan & Make up \$4237.00

\$13117

Grease Gutters provided? YES With Drain & Removable Caps

Hood Clearance reduction to Combustibles design /specs:

3"

Duct Clearance reduction to Combustibles design /specs:

2"

Vibration Isolation System:

NONE

Air Velocity within the duct system 1671 FT/MIN.

Grease accumulation prevention system:

Cleanouts Yes - as required

Grease Duct enclosure NELSON FIRE WRAP TWO HOUR RATING

Exhaust Termination Roof X Wall _____

Fire Suppression System ANSI R102

Exhaust fan mounting and clearance from the roof / wall or Combustibles:

ON 20" High Curbs To Be 16" Above Roof

Exhaust fan distance from property lines OVER 100 YDS

Exhaust fan distance from other vents or openings OVER 10'

Exhaust fan distance from adjacent buildings OVER 100 YDS

Exhaust fan height above adjoining grade 36'

Hood Specs

Style of Hood GREASE HOOD

Type of Filter 16" H.L. Classified High Efficiency 55 Baffle Grade

Height of filter above nearest cooking surface BETWEEN 33" TO 48" MAX

Capacity of hood CFM 2438 CFM

Make up Air system description and capacity

CAPTIVE AIR Model 5424 ND-2-PSP-F



General Building Permit Application

If you or the property owner owes real estate or personal property taxes or user charges on any property within the City, payment arrangements must be made before permits of any kind are accepted.

Location/Address of Construction:			
Total Square Footage of Proposed Structure		Square Footage of Lot	
Tax Assessor's Chart, Block & Lot Chart# Block# Lot#	Owner:		Telephone:
Lessee/Buyer's Name (if Applicable)	Applicant name, address & telephone:		Cost Of Work: \$ _____ Fee: \$ _____ C. of O Fee: \$ _____
Current legal use (i.e. single family) _____ If vacant, what was the previous use? _____ Proposed Specific use: _____ Is property part of a subdivision? _____ If yes, please name _____ Project description: _____			
Contractor's name, address & telephone:			
Who should we contact when the permit is ready: _____			
Mailing address:		Phone: _____	

Copy of Permit Attached

Please submit all of the information outlined in the Commercial Application Checklist. Failure to do so will result in the automatic denial of your permit.

In order to be sure the City fully understands the full scope of the project, the Planning and Development Department may request additional information prior to the issuance of a permit. For further information or to download copies of this form and other applications visit the Inspections Division on-line at www.portlandmaine.gov, or stop by the Inspections Division office, room 315 City Hall or call 874-8703.

I hereby certify that I am the Owner of record of the named property, or that the owner of record authorizes the proposed work and that I have been authorized by the owner to make this application as his/her authorized agent. I agree to conform to all applicable laws of this jurisdiction. In addition, if a permit for work described in this application is issued, I certify that the Code Official's authorized representative shall have the authority to enter all areas covered by this permit at any reasonable hour to enforce the provisions of the codes applicable to this permit.

Signature of applicant:	Date:
-------------------------	-------

This is not a permit; you may not commence ANY work until the permit is issued.