

DISPLAY THIS CARD ON PRINCIPAL FRONTAGE OF WORK



CITY OF PORTLAND

BUILDING PERMIT

This is to certify that Pingree 2000 Real Estate

Located At 1128 WESTBROOK ST

Job ID: 2012-03-3478-HVAC

CBL: 207- A-010-001

has permission to Install HTP Elite Boiler

provided that the person or persons, firm or corporation accepting this permit shall comply with all of the provisions of the Statutes of Maine and of the Ordinances of the City of Portland regulating the construction, maintenance and use of the buildings and structures, and of the application on file in the department.

Notification of inspection and written permission procured before this building or part thereof is lathed or otherwise closed-in. 48 HOUR NOTICE IS REQUIRED.

A final inspection must be completed by owner before this building or part thereof is occupied. If a certificate of occupancy is required, it must be

Fire Prevention Officer

Code Enforcement Officer / Plan Reviewer

THIS CARD MUST BE POSTED ON THE STREET SIDE OF THE PROPERTY
PENALTY FOR REMOVING THIS CARD

BUILDING PERMIT INSPECTION PROCEDURES

Please call 874-8703 or 874-8693 (ONLY)

or email: buildinginspections@portlandmaine.gov

With the issuance of this permit, the owner, builder or their designee is required to provide adequate notice to the city of Portland Inspections Services for the following inspections. Appointments must be requested 48 to 72 hours in advance of the required inspection. The inspection date will need to be confirmed by this office.

- **Please read the conditions of approval that is attached to this permit!! Contact this office if you have any questions.**
- **Permits expire in 6 months. If the project is not started or ceases for 6 months.**
- **If the inspection requirements are not followed as stated below additional fees may be incurred due to the issuance of a "Stop Work Order" and subsequent release to continue.**

The project cannot move to the next phase prior to the required inspection and approval to continue, REGARDLESS OF THE NOTICE OF CIRCUMSTANCES.

IF THE PERMIT REQUIRES A CERTIFICATE OF OCCUPANCY, IT MUST BE PAID FOR AND ISSUED TO THE OWNER OR DESIGNEE BEFORE THE SPACE MAY BE OCCUPIED.



PORTLAND MAINE

Strengthening a Remarkable City, Building a Community for Life • www.portlandmaine.gov

Acting Director of Planning and Urban Development
Gregory Mitchell

Job ID: 2012-03-3478-HVAC

Located At: 1128 WESTBROOK
ST

CBL: 207- A-010-001

Conditions of Approval:

Fire

Installation shall comply with City Code Chapter 10.

Fuel-fired boilers shall be protected in accordance with NFPA 101, *Life Safety Code*.

Installation shall comply with NFPA 211, *Standard for Chimneys, Fireplaces, Vents, and Solid Fuel-Burning Appliances*;

NFPA 54, *National Fuel Gas Code*;

NFPA 90A, *Standard for the Installation of Air-Conditioning and Ventilating Systems*;

NFPA 91, *Standard for Exhaust Systems for Air Conveying Vapors, Gases, Mists, and Noncombustible Particulate Solids*;

NFPA 70, *National Electrical Code*; and the manufacturer's published instructions.

City of Portland, Maine - Building or Use Permit Application

389 Congress Street, 04101 Tel: (207) 874-8703, FAX: (207) 8716

Job No: 2012-03-3478-HVAC	Date Applied: 3/12/2012	CBL: 207- A-010-001	
Location of Construction: 1128 WESTBROOK ST	Owner Name: PINGREE 2000 REAL ESTATE HOLDINGS	Owner Address: 600 CORPORATE PARK DR ST LOUIS, MO 63105	Phone:
Business Name: Enterprise Rent-A-Car	Contractor Name: Airtemp Inc	Contractor Address: 11 Wallace AVE SOUTH PORTLAND MAINE 04106	Phone: (207) 774-2300
Lessee/Buyer's Name:	Phone:	Permit Type: HVAC	Zone: AB
Past Use: Car Rental (under construction)	Proposed Use: Same: Car Rental – to install HTP Elite Heating Boiler	Cost of Work: \$30,000.00	CEO District:
		Fire Dept: <input checked="" type="checkbox"/> Approved w/conditions <input type="checkbox"/> Denied <input type="checkbox"/> N/A	Inspection: Use Group: Type: HVAC
Proposed Project Description: HTP Elite Boiler		Signature: <i>Capit Perone 3/14/12</i> Pedestrian Activities District (P.A.D.)	
Permit Taken By: Brad		Zoning Approval	

<p>1. This permit application does not preclude the Applicant(s) from meeting applicable State and Federal Rules.</p> <p>2. Building Permits do not include plumbing, septic or electrical work.</p> <p>3. Building permits are void if work is not started within six (6) months of the date of issuance. False informatin may invalidate a building permit and stop all work.</p>	Special Zone or Reviews <input type="checkbox"/> Shoreland <input type="checkbox"/> Wetlands <input type="checkbox"/> Flood Zone <input type="checkbox"/> Subdivision <input type="checkbox"/> Site Plan <input type="checkbox"/> Maj <input type="checkbox"/> Min <input checked="" type="checkbox"/> MM Date: <i>OK 3/12/12</i>	Zoning Appeal <input type="checkbox"/> Variance <input type="checkbox"/> Miscellaneous <input type="checkbox"/> Conditional Use <input type="checkbox"/> Interpretation <input type="checkbox"/> Approved <input type="checkbox"/> Denied Date:	Historic Preservation <input checked="" type="checkbox"/> Not in Dist or Landmark <input type="checkbox"/> Does not Require Review <input type="checkbox"/> Requires Review <input type="checkbox"/> Approved <input type="checkbox"/> Approved w/Conditions <input type="checkbox"/> Denied Date: <i>[Signature]</i>
	CERTIFICATION		

I hereby certify that I am the owner of record of the named property, or that the proposed work is authorized by the owner of record and that I have been authorized by the owner to make this application as his authorized agent and I agree to conform to all applicable laws of this jurisdiction. In addition, if a permit for work described in the application is issued, I certify that the code official's authorized representative shall have the authority to enter all areas covered by such permit at any reasonable hour to enforce the provision of the code(s) applicable to such permit.

SIGNATURE OF APPLICANT	ADDRESS	DATE	PHONE
RESPONSIBLE PERSON IN CHARGE OF WORK, TITLE		DATE	PHONE



Entered 3/12
FILL IN AND SIGN WITH INK

(B)

APPLICATION FOR PERMIT HEATING OR POWER EQUIPMENT

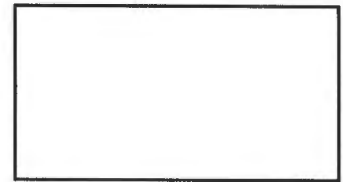

To the INSPECTOR OF BUILDINGS, PORTLAND, ME.

B 2012-03-3478 AB

The undersigned hereby applies for a permit to install the following heating, cooking or power equipment in accordance with the Laws of Maine, the Building Code of the City of Portland, and the following specifications:

Location / CBL 1128 Westbrook Street Use of Building car wash / Maintenance Date 3/12/12
Name and address of owner of appliance Enterprise - Rent - A - Car

Installer's name and address Airtamp 11 Wallace Ave.
South Portland, ME 04106 Telephone 207-774-2300

Location of appliance:

- Basement
- Floor
- Attic
- Roof

Type of Fuel:

- Gas
- Oil
- Solid

Appliance Name: HTP Elite Heating Boiler
U.L. Approved Yes No

Will appliance be installed in accordance with the manufacture's installation instructions? Yes No

IF NO Explain: _____

The Type of License of Installer:

- Master Plumber # _____
- Solid Fuel # _____
- Oil # _____
- Gas # PNT 1977
- Other _____

Type of Chimney:

- Masonry Lined
Factory built _____
- Metal
Factory Built U.L. Listing # _____
- Direct Vent
Type DVC UL# _____

Type of Fuel Tank

- Oil N/A
- Gas Natural Gas

Size of Tank N/A

Number of Tanks N/A

Distance from Tank to Center of Flame N/A feet.

Cost of Work: \$ 26,000

Permit Fee: \$ 280

Approved

Fire: _____
Ele.: _____
Bldg.: _____

Approved with Conditions

See attached letter or requirement

Inspector's Signature

Date Approved

Signature of Installer

Peter L.

White - Inspection Yellow - File Pink - Applicant's Gold - Assessor's Copy

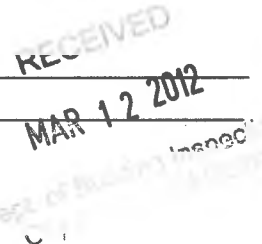



PORTLAND MAINE

Strengthening a Remarkable City, Building a Community for Life • www.portlandmaine.gov

Receipts Details:

Tender Information: Check , Check Number: 53413
Tender Amount: 280.00

Receipt Header:

Cashier Id: bsaucier
Receipt Date: 3/12/2012
Receipt Number: 41633

Receipt Details:

Referance ID:	5543	Fee Type:	BP-Constr
Receipt Number:	0	Payment Date:	
Transaction Amount:	280.00	Charge Amount:	280.00
Job ID: Job ID: 2012-03-3478-HVAC - HTP Elite Boiler			
Additional Comments: 1128 Westbrook			

Thank You for your Payment!

EL-399

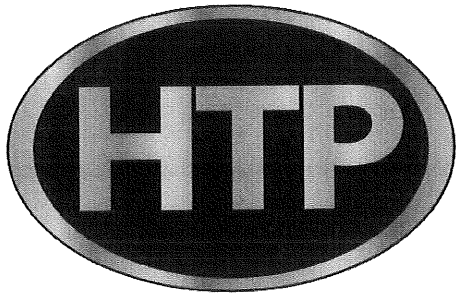

Elite

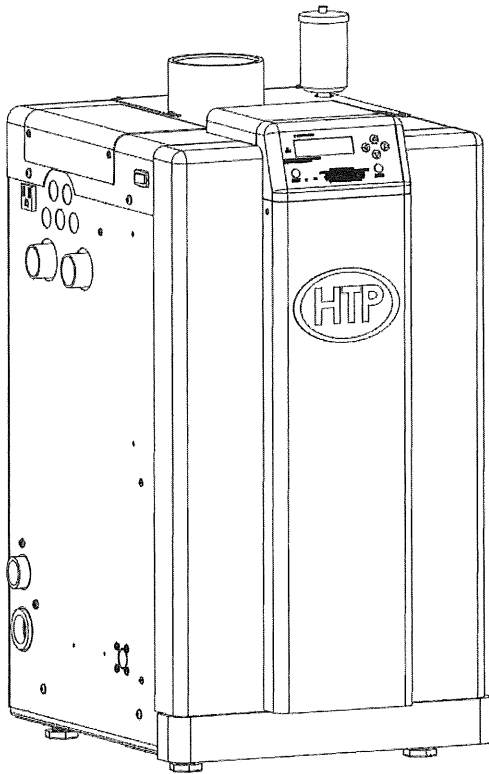

RECEIVED
MAR 12 2012
Dept. of Building Inspections
City of Portland Maine

INSTALLATION

START-UP

MAINTENANCE

PARTS

Elite Models*
EL-80 / 110 / 150 / 220 / 299 / 399

*A suffix of "LP" denotes propane gas
*A suffix of "N" denotes natural gas



WARNING

This manual must only be used by a qualified heating installer/service technician. Read all instructions in this manual before installing. Perform steps in the order given. Failure to comply could result in substantial property damage, severe personal injury, or death.

NOTICE: HTP reserves the right to make product changes or updates without notice and will not be held liable for typographical errors in literature.

NOTE TO CONSUMER: PLEASE KEEP ALL INSTRUCTIONS FOR FUTURE REFERENCE.

⚠ WARNING

IF THE INFORMATION IN THIS MANUAL IS NOT FOLLOWED EXACTLY, A FIRE OR EXPLOSION MAY RESULT, CAUSING PROPERTY DAMAGE, PERSONAL INJURY, OR LOSS OF LIFE. DO NOT STORE GASOLINE OR OTHER FLAMMABLE VAPORS AND LIQUIDS IN THE VICINITY OF THIS OR ANY OTHER APPLIANCE.

WHAT TO DO IF YOU SMELL GAS

- Do not try to light any appliance.
- Do not touch any electrical switch.
- Do not use any phone in your building.
- Immediately call your gas supplier from a neighbor's phone. Follow the gas supplier's instructions.
- If you cannot reach your gas supplier, call the fire department. Installation and service must be provided by a qualified installer, service agency, or the gas supplier.

FOR YOUR SAFETY READ BEFORE OPERATING

WARNING: If you do not follow these instructions exactly, a fire or explosion may result, causing property damage, personal injury or loss of life.

A. This appliance does not have a pilot. It is equipped with an ignition device which automatically lights the burner. Do not try to light the burner by hand.

B. BEFORE OPERATING smell all around the appliance area for gas. Be sure to smell next to the floor because some gas is heavier than air and will settle on the floor.

WHAT TO DO IF YOU SMELL GAS

- Do not try to light any appliance
- Do not touch any electric switch; do not use any phone in your building
- Immediately call your gas supplier from a neighbor's phone. Follow the gas suppliers' instructions.

• If you cannot reach your gas supplier, call the fire department.

C. Use only your hand to turn the gas control knob. Never use tools. If the handle will not turn by hand, don't try to repair it, call a qualified service technician. Force or attempted repair may result in a fire or explosion.

D. Do not use this appliance if any part has been under water. Immediately call a qualified service technician to inspect the appliance and to replace any part of the control system and any gas control which has been under water.

OPERATING INSTRUCTIONS

1. STOP! Read the safety information above.
2. Set the thermostat to lowest setting.
3. Turn off all electric power to the appliance.
4. This appliance is equipped with an Ignition device which automatically lights the burner. Do not try to light the burner by hand.

GAS VALVE
ON

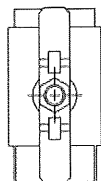

GAS VALVE
OFF

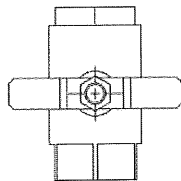

5. Remove front cover.
6. Turn gas shutoff valve to "off". Handle will be across the piping, do not force.
7. Wait five (5) minutes to clear out any gas. If you then smell gas, STOP! Follow "B" in the safety information above on this label. If you don't smell gas, go to next step.
8. Turn gas shutoff valve to "on". Handle will be in line with piping.
9. Install Front Cover.
10. Turn on all electric power to appliance.
11. Set thermostat to desired setting.
12. If the appliance will not operate, follow the instructions "To Turn Off Gas To Appliance" and call your service technician or gas supplier.

TO TURN OFF GAS TO APPLIANCE

1. Set the thermostat to lowest setting.
2. Turn off all electric power to the appliance if service is to be performed.
3. Remove Front Cover.
4. Turn gas shutoff valve to "off". Handle will be across the piping. Do not force.
5. Install Front Cover.

SPECIAL ATTENTION BOXES

The following defined terms are used throughout this manual to bring attention to the presence of hazards of various risk levels, or to important product information.

DANGER

DANGER indicates an imminently hazardous situation which, if not avoided, will result in death or serious injury.

WARNING

WARNING indicates a potentially hazardous situation which, if not avoided, could result in death or serious injury.

CAUTION

CAUTION indicates a potentially hazardous situation which, if not avoided, may result in minor or moderate injury.

CAUTION

CAUTION used without the safety alert symbol indicates a potentially hazardous situation which, if not avoided, may result in property damage.

FOREWORD

This manual is intended to be used in conjunction with other literature provided with the appliance. This includes all related control information. It is important that this manual, all other documents included with this system, and additional publications including the National Fuel Gas Code, ANSI Z223.1-2002, be reviewed in their entirety before beginning any work.

Installation should be made in accordance with the regulations of the local code authorities and utility companies which pertain to this type of water heating equipment.

NOTE: HTP, Inc. reserves the right to modify product technical specifications and components without prior notice.

FOR THE INSTALLER

WARNING

This manual must only be used by a qualified heating installer/service technician. Read all instructions in this manual before installing. Perform steps in the order given. Failure to comply could result in substantial property damage, severe personal injury, or death.

This appliance must be installed by qualified and licensed personnel. The installer should be guided by the instructions furnished with the boiler, and with local codes and utility company requirements. In the absence of local codes, preference should be given to the National Fuel Gas Code, ANSI Z223.1-2002.

INSTALLATIONS MUST COMPLY WITH:

Local, state, provincial, and national codes, laws, regulations and ordinances.

The latest version of the National Fuel Gas Code, ANSI Z223.1, from American Gas Association Laboratories, 8501 East Pleasant Valley Road, Cleveland, OH 44131.

In Canada – CGA No. B149 (latest version), from Canadian Gas Association Laboratories, 55 Scarsdale Road, Don Mills, Ontario, Canada M3B 2R3. Also, Canadian Electrical Code C 22.1, from Canadian Standards Association, 5060 Spectrum Way, Suite 100, Mississauga, Ontario, Canada L4W 5N6.

Code for the installation of Heat Producing Appliances (latest version), from American Insurance Association, 85 John Street, New York, NY 11038.

The latest version of the National Electrical Code, NFPA No. 70.

NOTE: The gas manifold and controls met safe lighting and other performance criteria when the boiler underwent tests specified in ANSI Z21.13 – latest edition.

TABLE OF CONTENTS

PART 1 – GENERAL SAFETY INFORMATION	7
A. PRECAUTIONS.....	7
B. IMPROPER COMBUSTION	8
C. GAS.....	8
D. WHEN SERVICING THE BOILER	8
E. BOILER WATER	8
F. BOILER WATER CHEMISTRY*	8
G. FREEZE PROTECTION FLUIDS.....	8
PART 2 – BEFORE YOU START	9
A. WHAT'S IN THE BOX	9
B. HOW BOILER OPERATES	9
C. OPTIONAL EQUIPMENT.....	10
PART 3 – PREPARE BOILER LOCATION	11
A. BEFORE LOCATING THE BOILER	11
B. LEVELING AND DIMENSIONS.....	12
C. CLEARANCES FOR SERVICE ACCESS	15
D. RESIDENTIAL GARAGE INSTALLATION	15
E. EXHAUST VENT AND INTAKE AIR VENT	15
F. PREVENT COMBUSTION AIR CONTAMINATION.....	15
G. REMOVING A BOILER FROM A COMMON VENT SYSTEM	16
H. UNCRATING THE BOILER.....	17
PART 4 – BOILER PIPING	17
A. RELIEF VALVE	17
B. GENERAL PIPING INFORMATION	18
C. BACKFLOW PREVENTER	18
D. SYSTEM WATER PIPING METHODS.....	19
E. CIRCULATORS.....	19
F. HYDRONIC PIPING WITH CIRCULATORS, ZONE VALVES, AND MULTIPLE BOILERS	20

G. PIPING DETAILS*	20
H. PIPING INSTALLATION	25
I. CIRCULATOR SIZING	26
J. CHECK/CONTROL WATER CHEMISTRY	27
K. FILL AND PURGE HEATING SYSTEM	29
L. GLYCOL ANTIFREEZE SOLUTIONS	29
M. ZONING WITH ZONE VALVES	30
N. ZONING WITH CIRCULATORS	30
O. MULTIPLE BOILERS	30
PART 5 – VENTING, COMBUSTION AIR, AND CONDENSATE REMOVAL	30
A. GENERAL	30
B. APPROVED MATERIALS FOR EXHAUST AND INTAKE AIR VENTS	31
C. REQUIREMENTS FOR INSTALLATION IN CANADA	31
D. EXHAUST VENT AND INTAKE AIR VENT PIPE LOCATION	32
E. EXHAUST VENT AND INTAKE AIR VENT SIZING	35
F. LONGER VENT RUNS	35
G. EXHAUST VENT AND INTAKE AIR PIPE INSTALLATION	36
H. SIDEWALL VENTING	37
I. VERTICAL VENTING	38
J. HORIZONTAL VENTING	39
K. UNBALANCED FLUE / VERTICAL VENT	40
L. VENTING THROUGH AN EXISTING SYSTEM	41
1. CONCENTRIC VENTING THROUGH AN EXISTING SYSTEM	41
2. VENTING AS A CHASE	43
M. INDOOR COMBUSTION AIR INSTALLATION IN CONFINED OR UNCONFINED SPACE	44
PART 6 – GAS PIPING	46
A. GAS CONNECTION	46
B. GAS PIPING	47
C. CHECK INLET GAS PRESSURE	47
D. BOILER GAS VALVE	48
PART 7 – FIELD WIRING	49
A. INSTALLATION MUST COMPLY WITH:	49
B. FIELD WIRING TERMINATIONS	49
C. FIELD WIRING	49
D. LINE VOLTAGE WIRING FOR STANDARD BOILER	49
E. ALARM CONNECTIONS	50
F. LOW VOLTAGE CONNECTIONS FOR STANDARD BOILER	50
G. THERMOSTAT	50

H. OUTDOOR SENSOR.....	51
I. INDIRECT SENSOR.....	51
J. OPTIONAL 0-10 VOLT BUILDING CONTROL SIGNAL.....	51
K. OPTIONAL UL353 LOW WATER CUT-OFF INTERFACE KIT.....	51
L. WIRING OF CASCADE SYSTEM COMMUNICATION BUS.....	52
M. CASCADE MASTER PUMP AND SENSOR WIRING.....	52
N. CASCADE FOLLOWER PUMP AND SENSOR WIRING.....	53
PART 8 – START-UP PREPARATION.....	57
A. CHECK / CONTROL WATER CHEMISTRY.....	57
B. CHECK FOR GAS LEAKS.....	58
C. FREEZE PROTECTION (WHEN USED).....	58
D. FILL AND TEST WATER SYSTEM.....	58
E. PURGE AIR FROM WATER SYSTEM.....	59
F. CHECK THERMOSTAT CIRCUIT(S).....	59
G. CONDENSATE REMOVAL.....	60
H. FINAL CHECKS BEFORE STARTING BOILER.....	60
I. CASCADE SYSTEM.....	60
J. LOCKOUT CONDITION.....	61
PART 9 – START-UP PROCEDURE.....	61
A. CONTROL OVERVIEW.....	62
B. NAVIGATION OF THE DISPLAY.....	62
C. OPERATING INSTRUCTIONS.....	63
D. PROGRAMMING BOILER SETTINGS.....	63
E. PROGRAMMING THE SYSTEM SETTING.....	64
F. SYSTEM SETTING PROGRAM NAVIGATION.....	65
G. RESETTING THE MAINTENANCE SCHEDULE.....	67
PART 10 – START-UP PROCEDURES FOR THE INSTALLER.....	67
A. BOILER CONTROL STATUS MENU.....	67
B. BOILER TEST MODE.....	69
C. CASCADE MENU.....	69
D. TEST MODE ACCESS.....	70
PART 11 – TROUBLESHOOTING.....	71
A. BOILER ERROR CODE.....	71
B. BOILER ERROR.....	71
C. BOILER FAULT.....	71
D. USER INTERFACE DISPLAY.....	72
PART 12 – MAINTENANCE.....	77
A. MAINTENANCE PROCEDURES.....	77

B. COMBUSTION CHAMBER COIL CLEANING INSTRUCTIONS FOR BOILER	78
C. CLEANING WATER SIDE OF HEAT EXCHANGER.....	79
BOILER START-UP REPORT	84
MAINTENANCE REPORT	85
MAINTENANCE NOTES.....	88
HTP CUSTOMER INSTALLATION RECORD FORM	89

PART 1 – GENERAL SAFETY INFORMATION

A. PRECAUTIONS

This appliance is for indoor installations only. Clearance to combustible materials: 0" top, bottom, sides and back. Left side has all boiler mechanical connections. Front must have room for service, 24" recommended. (A combustible door or removable panel is acceptable front clearance.) This appliance has been approved for closet installation. Do not install this appliance directly on carpeting. For installation on combustible flooring. Category IV vent systems only.

WARNING

INSTALLER – Read all instructions in this manual before installing. Perform steps in the order given.

USER – This manual is for use only by a qualified heating installer/service technician. Refer to user's information manual for your reference. Have this boiler serviced/inspected by a qualified service technician annually.

FAILURE TO ADHERE TO THE GUIDELINES ON THIS PAGE CAN RESULT IN SUBSTANTIAL PROPERTY DAMAGE, SEVERE PERSONAL INJURY, OR DEATH.

DO NOT USE THIS APPLIANCE IF ANY PART HAS BEEN UNDERWATER. Immediately call a qualified service technician. Replace any part of the control unit that has been under water.

NOTE: If the boiler is exposed to the following, do not operate until all corrective steps have been made by a qualified serviceman:

1. FIRE
2. DAMAGE
3. WATER

Any claims for damage or shortage in shipment must be filed immediately against the transportation company by the consignee.

WARNING

Be sure to disconnect electrical power before opening boiler cabinet. Failure to do so could result in an electrical shock that could result in serious injury or death.

CAUTION

Due to the low water content of the boiler, improper sizing of the boiler with regard to heating system load will result in excessive cycling and accelerated component failure. HTP **DOES NOT** warrant failures caused by improperly sized boiler applications. **DO NOT** oversize the boiler to the system. Modular boiler installations greatly reduce the likelihood of boiler oversizing.

B. IMPROPER COMBUSTION**⚠ WARNING**

Do not obstruct the flow of combustion and ventilating air. Adequate air must be provided for safe operation.

C. GAS

Should overheating or gas supply fail to shut off, do not turn off or disconnect electrical supply to the circulator. Instead, shut off the gas supply at a location external to the appliance.

D. WHEN SERVICING THE BOILER

- To avoid electric shock, disconnect electrical supply before performing maintenance.
- To avoid severe burns, allow boiler to cool.

E. BOILER WATER

- If you have an old system with cast iron radiators, thoroughly flush the system (without boiler connected) to remove sediment. The high-efficiency heat exchanger can be damaged by build-up or corrosion due to sediment. HTP recommends a suction strainer in this type of system.
- Do not use petroleum-based cleaning or sealing compounds in boiler system. Gaskets and seals in the system may be damaged, possibly resulting in substantial property damage.
- Do not use "homemade cures" or "boiler patent medicines". Substantial property damage, damage to boiler, and/or serious personal injury may result.
- Continual fresh make-up water will reduce boiler life. Mineral buildup in the heat exchanger reduces heat transfer, overheats the stainless steel heat exchanger, and causes failure. Addition of oxygen from make-up water can cause internal corrosion in system components. Leaks in the boiler or piping must be repaired at once.

NOTE: DO NOT add cold make up water to the system when the boiler is hot. Thermal shock can potentially cause cracks in the heat exchanger. Such damage IS NOT covered by warranty.

F. BOILER WATER CHEMISTRY*

- Sodium less than 20mGL.
- Water pH between 6.0 and 8.0
 - Maintain water pH between 6.0 and 8.0. Check with litmus paper or have it chemically analyzed by water treatment company.
 - If the pH differs from above, consult local water treatment company for treatment needed.
- Hardness less than 7 grains
 - Consult local water treatment companies for unusually hard water areas (above 7 grains hardness).
- Chlorine concentration less than 200 ppm
 - Using chlorinated fresh water should be acceptable as levels are typically less than 5 ppm.
 - Do not connect the boiler to directly heat swimming pool or spa water.
 - Do not fill boiler or operate with water containing chlorine in excess of 200 ppm.
- ***NOTE:** It is recommended to clean heat exchanger at least once a year to prevent lime scale buildup. To clean the heat exchanger, follow the maintenance procedure in Part 13, Section B of this manual.

G. FREEZE PROTECTION FLUIDS**CAUTION**

NEVER use automotive or standard glycol antifreeze, or ethylene glycol made for hydronic systems, with this boiler. Use only inhibited propylene glycol solutions, which are specifically formulated for hydronic systems. Ethylene glycol is toxic and can attack gaskets and seals used in hydronic systems.

CAUTION

Consider boiler piping and installation when determining boiler location.

PART 2 – BEFORE YOU START

A. WHAT'S IN THE BOX

Also included with the boiler:

- Temperature and Pressure Gauge (Part #7450-222)
- Pressure Relief Valve (Part #7250P-219 for EL80/110/150, #7350P-065 for EL220/299/399)
- Indirect Sensor
- Outdoor Sensor
- Intake PVC Tee with Screens
- Exhaust PVC Coupling with Screens
- Outlet Combination Fitting (1" - Part #7450P-134 for EL80/110/150/220, 1.25" - #7450-135 for EL299, 1.5" - #7450-136 for EL399)
- Installation Manual
- Warranty
- CSD-1 Form
- H-3 Data Sheet
- NAT to LP Conversion Kit (Part #7450P-223) (Included with NAT models)
- LP to NAT Conversion Kit (Part #7450P-224) (Included with LP models)

B. HOW BOILER OPERATES

Elite[®] condensing technology intelligently delivers hydronic heating while maximizing efficiency. Outlined below are the features of the system and how they operate:

Stainless Steel Heat Exchanger - The highly efficient stainless steel heat exchanger is designed to extract all available heat from the supply line before it is exhausted.

Modulating Combustion System - The combustion system will modulate the output of the burner during operation to match the system demand and achieve the control set point while in operation. The set point can change by internal or external signals which enhance the overall performance of the system.

Control – The integrated control system monitors the system and regulates fan speed to control boiler output. This allows the boiler to deliver only the amount of heat energy required and nothing more.

The control can be set up to monitor outdoor temperature through an outdoor sensor to regulate boiler set point. The system can be further enhanced by installing an indirect water heater to provide domestic hot water.

The control can regulate the output of multiple boilers through its cascade system function. The cascade system is capable of connecting up to eight boilers together in such a way that they function as one boiler system. This allows for greater turn down ratios and provides systematic control of the multiple boilers in an installation to minimize downtime and maximize efficiency.

The cascade system works by establishing one boiler as the master and the other connected boilers as followers. The master boiler requires a sensor to provide feedback on set point temperature in order to adjust heating input from the connected boilers. Each cascaded boiler will have its own pump to provide maximum flow and control heat exchanger flow rate.

Text Display and Operational LED Light Indicators – The display allows the user to change system parameters and monitor system outputs.

Gas Valve – Senses suction from the blower, allowing gas to flow only if powered and combustion air is flowing.

All Metal Integrated Venturi – Controls air and gas flow into the burner.

Burner – Constructed of high grade stainless steel, the burner uses premixed air and gas fuel and provides a wide range of firing rates.

Spark Ignition – The burner is ignited by applying high voltage through the system spark electrode. This causes the spark from the electrode to ignite mixed gas off of the burner.

Supply Water Temperature Sensor – This sensor monitors the boiler outlet water temperature (System Supply). The control adjusts the boiler firing rate so the supply temperature will match the boiler set point.

Return Water Temperature Sensor – This sensor monitors the boiler return water temperature (System Return).

Flue Sensor – Monitors flue temperature and adjusts firing rate.

Temperature and Pressure Gauge – Allows the user to monitor system temperature and pressure.

Electrical field connections with terminal strips – The electrical cover allows easy access to the line voltage and low voltage terminals strips which are clearly marked to facilitate wiring of the boiler.

Condensation Collection System – This boiler is a high efficiency appliance, therefore the boiler will produce condensate. The collection system has a float switch which monitors the condensation level and prevents condensation from backing up into the combustion system. Inside the collection system there is a built in trap which seals the combustion system from the connected drain. This condensate should be neutralized to avoid damage to the drainage system or piping.

Outdoor Sensor – Monitors outdoor temperature and adjusts unit set point to provide greater efficiency.

0-10 Volt Input – Allows Installer to connect a BMS (Building Management System) to control the boiler.

Condensate Flue Check System – The check system prevents exhaust from the heat exchanger from backing up into cabinet.

Pump Service Mode – Allows manual operation of pumps to commission system and check pump operation.

The Vision II System (Optional) – Allows the user to supply mixed temperatures in up to eight zones. The Vision II system controls the temperature to each zone by employing three way mixing valves. The Vision II also controls the output temperature of the boiler to assure accurate temperature delivery to all connected zones.

C. OPTIONAL EQUIPMENT

Below is a list of optional equipment available from HTP. These additional options may be purchased through your HTP distributor:

- Wall Mount Bracket (Part # 7450P-211)
- System Sensor (Part # 7250P-324)
- Indirect Tank Sensor (Part # 7250P-325)
- 3" PVC Concentric Vent Kit (Part # KGAVT0601CVT)
- 3" Stainless Steel Outside Termination Vent Kit (Part # V1000)
- 4" Stainless Steel Outside Termination Vent Kit (Part # V2000)
- 6" Stainless Steel Outside Termination Vent Kit (Part # V3000)

- 3" Polypro Vent Kit (Part # 8400P-001)
- 3" Polypro Pipe (33' length Part # 8400P-002, 49.5' length Part # 8400P-003)
- U.L. 353 Compliant Low Water Cut-Off Interface Kit with Manual Reset (Part # 7450P-225)
- Manual Reset High Limit (Part # 7450P-217)
- Alarm System (Part # 7350P-602) (to monitor any failure)
- PC Connection Kit (Part # 7250P-320)
- Condensate Neutralizer (Part # 7450P-212 for EL-80/110/150/220/299, Part # 7350P-611 for EL-399)
- Flow Switch Kit (Part # 7450P-213 for EL-80/110/150/220, Part # 7450P-214 for EL-299, Part # 7450P-215 for EL-399)
- Vision II (Part # 7250P-322)

PART 3 – PREPARE BOILER LOCATION

Before considering location, there are many factors to be addressed. Piping, Venting, and Condensation Removal are just a few of the important issues covered in detail in this manual. Please read the entire manual before attempting installation. Doing so could save time and money.

WARNING

This appliance is certified for indoor installations only. Do not install the appliance outdoors or locate in areas where it will be exposed to freezing temperatures or to temperatures exceeding 100°F. Failure to install this appliance indoors could result in substantial property damage, severe personal injury, or death.

WARNING

Do not mount the boiler to a hollow wall. Mount to the studs only. Failure to do so will result in substantial property damage, and could result in severe personal injury or death.

CAUTION

Consider piping and installation when determining boiler location.

WARNING

Use extreme care not to drop the boiler or cause bodily injury while lifting or mounting the boiler onto the optional wall mount bracket. Failure to do so will result in property damage, and could result in severe personal injury or death.

A. BEFORE LOCATING THE BOILER

1. Check for nearby connections to:
 - System water piping
 - Venting connections
 - Gas supply piping
 - Electrical power
 - Condensate drain
2. Check area around boiler. Remove any combustible materials, gasoline, and other flammable liquids.

WARNING

Failure to keep boiler area clear and free of combustible materials, liquids, and vapors can result in substantial property damage, severe personal injury, or death.

3. Gas control system components must be protected from dripping water during operation and service.
4. If the boiler is to replace an existing boiler, check for and correct any existing system problems, such as:
 - System leaks
 - Location that could cause the system and boiler to freeze and leak.
 - Incorrectly-sized expansion tank
5. Clean and flush system when reinstalling a boiler.

⚠ WARNING

Gas conversion should be performed **BEFORE** the boiler is installed. Carefully follow the gas conversion instructions when performing the conversion. Failure to do so could result in property damage, severe personal injury, or death.

B. LEVELING AND DIMENSIONS

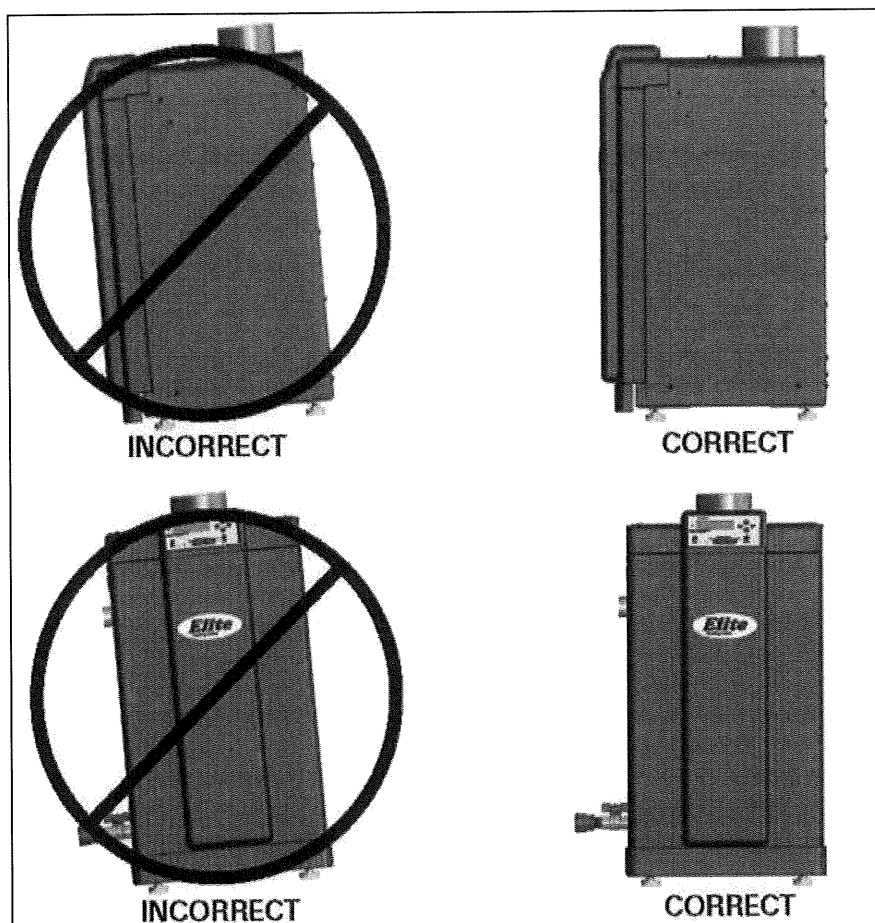

Figure 1

⚠ CAUTION

In order for the condensate to properly flow out of the collection system, the area where you locate the boiler must be level. The boiler comes equipped with leveling feet. Should you find the floor beneath the boiler is uneven, adjust the leveling feet with a wrench.

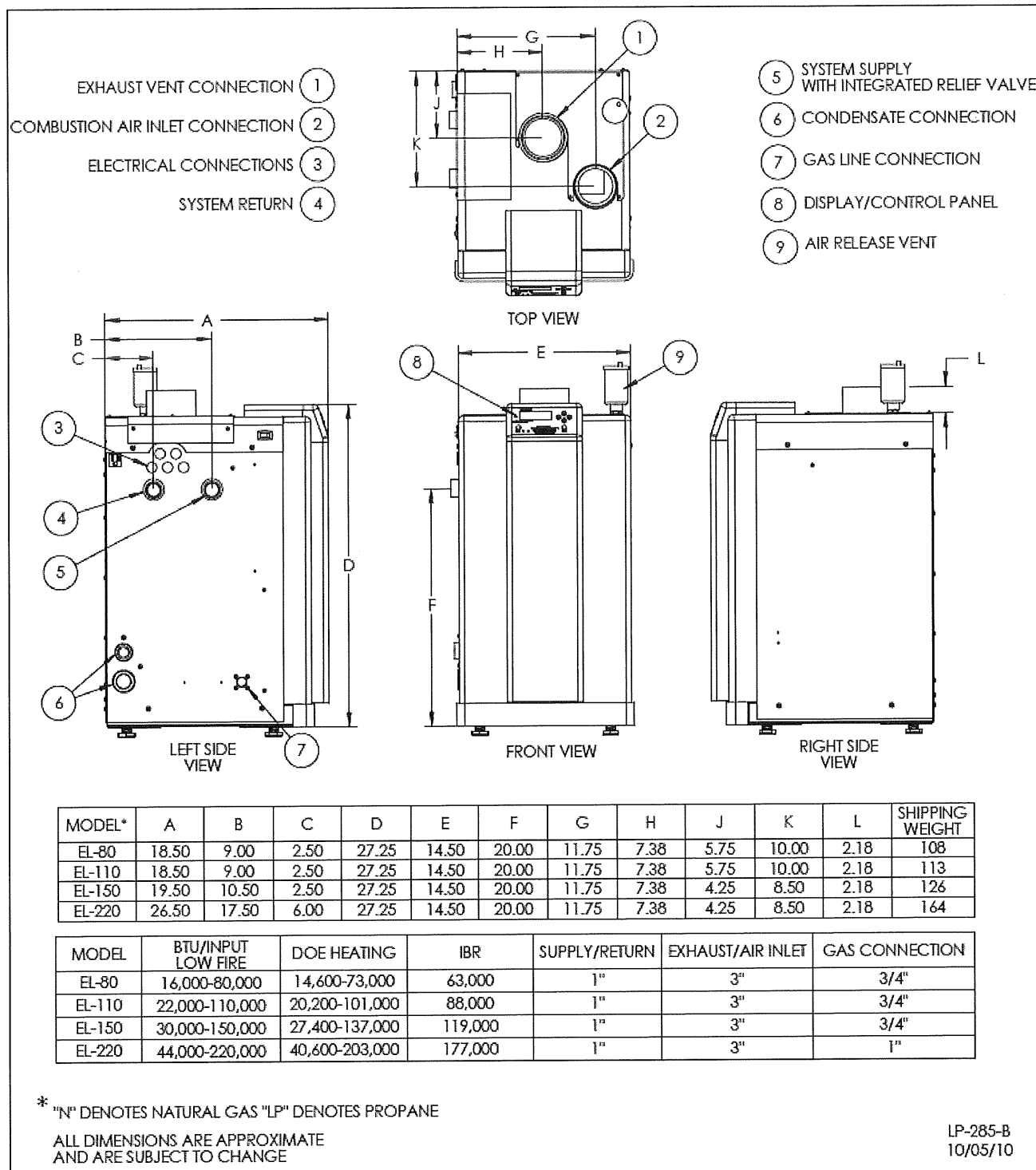

Figure 2

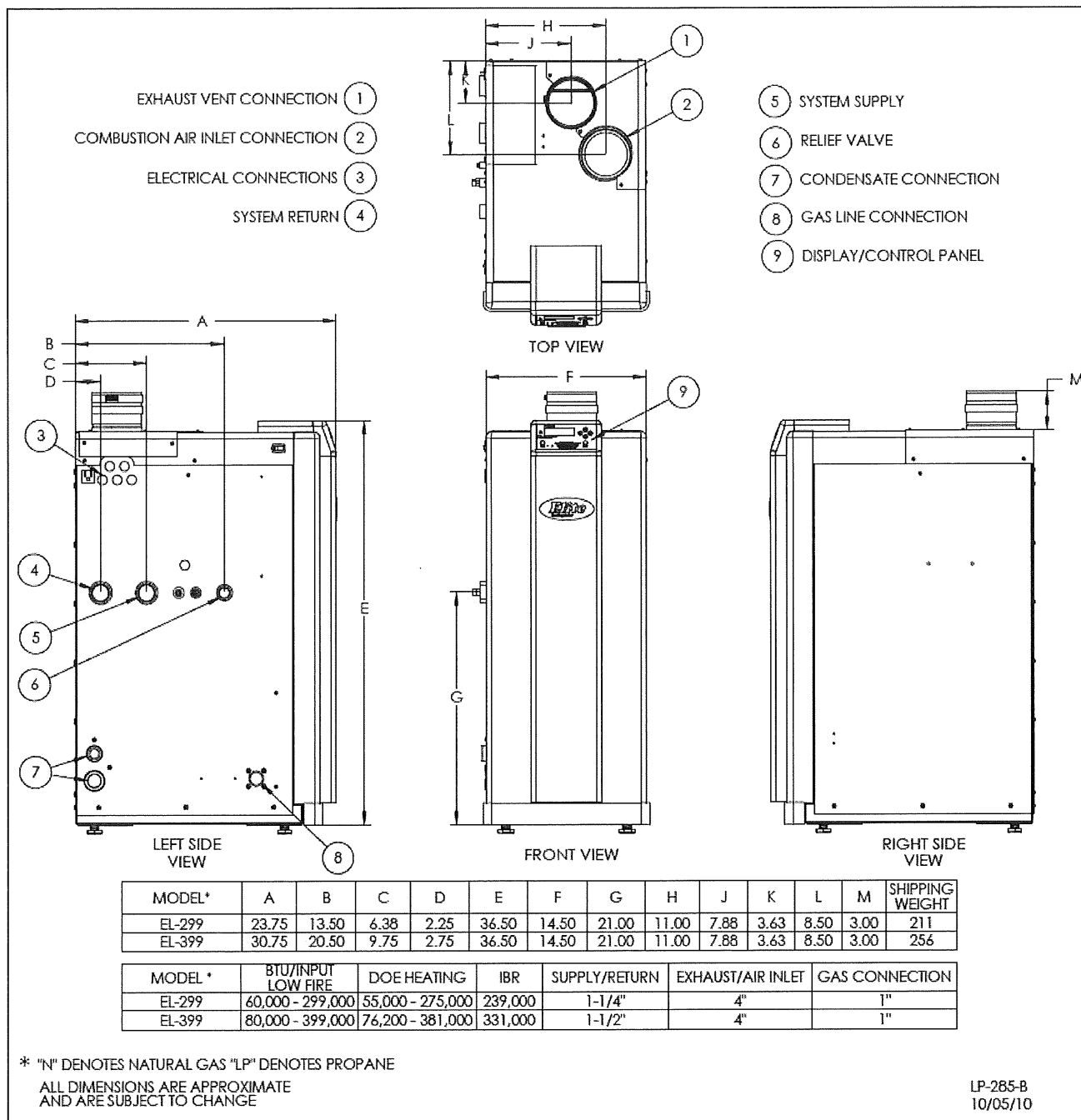

Figure 3

C. CLEARANCES FOR SERVICE ACCESS

See Figure 4 for recommended service clearances. If you do not provide the minimum clearances shown, it might not be possible to service the boiler without removing it from the space.

⚠ WARNING

Space must be provided with combustion / ventilation air openings correctly sized for all other appliances located in the same space as the boiler. The boiler cover must be securely fastened to prevent it from drawing air from the boiler room. This is particularly important if the boiler is in a room with other appliances. Failure to comply with the above warnings could result in substantial property damage, severe personal injury, or death.

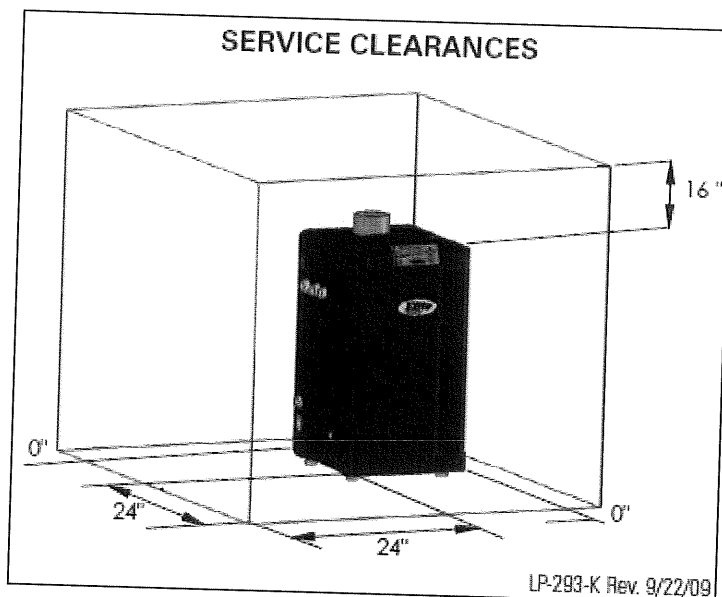

Figure 4

D. RESIDENTIAL GARAGE INSTALLATION

PRECAUTIONS

If the boiler is located in a residential garage, per ANSI Z223.1:

- Mount the bottom of the boiler a minimum of 18" above the floor of the garage, to ensure the burner and ignition devices are well off the floor.
- Locate or protect the boiler so it cannot be damaged by a moving vehicle.

E. EXHAUST VENT AND INTAKE AIR VENT

⚠ WARNING

Vents must be properly supported. The boiler intake and exhaust connections are not designed to carry heavy weight. Vent support brackets must be within 1' of the boiler and the balance at 4' intervals. Venting must be readily accessible for visual inspection for the first 3' from the boiler.

The boiler is rated ANSI Z21.13 Category IV (pressurized vent, likely to form condensate in the vent), and requires a special vent system designed for pressurized venting.

You must also install air intake piping from outdoors to the boiler flue adaptor. The resultant installation is categorized as direct vent (sealed combustion). **NOTE:** To prevent combustion air contamination, see Table 1 in this section when considering exhaust vent and intake air vent termination.

Intake and exhaust vents must terminate near each other and may be vented vertically through the roof or out a side wall. Intake and exhaust venting methods are detailed in the Venting Section. Do not attempt installation using any other means. Be sure to locate the boiler so intake and exhaust vent piping can be routed through the building and properly terminated. The air intake and exhaust vent piping lengths, routing and termination method must all comply with methods and limits given in the venting section.

F. PREVENT COMBUSTION AIR CONTAMINATION

Install intake piping for the boiler as described in the Venting section. Do not terminate exhaust in locations that can allow contamination of intake air.

⚠ WARNING

You must pipe outside air to the boiler intake. Ensure that the intake air will not contain any of the contaminants below. For example, do not pipe intake vent near a swimming pool. Avoid areas subject to exhaust fumes from laundry facilities. These areas always contain contaminants. Contaminated air will damage the boiler, resulting in possible substantial property damage, severe personal injury, or death.

PRODUCTS TO AVOID	AREAS LIKELY TO HAVE CONTAMINANTS
Spray cans containing fluorocarbons	Dry cleaning/laundry areas and establishments
Permanent wave solutions	Swimming pools
Chlorinated waxes/cleaners	Metal fabrication plants
Chlorine-based swimming pool chemicals	Beauty shops
Calcium chloride used for thawing	Refrigeration repair shops
Sodium chloride used for water softening	Photo processing plants
Refrigerant leaks	Auto body shops
Paint or varnish removers	Plastic manufacturing plants
Hydrochloric or Muriatic acid	Furniture refinishing areas and establishments
Cements and glues	New building construction
Antistatic fabric softeners used in clothes dryers	Remodeling areas
Chlorine-type bleaches, laundry detergents, and cleaning solvents	Garages and workshops
Adhesives used to fasten building products	

Table 1

NOTE: DAMAGE TO THE BOILER CAUSED BY EXPOSURE TO CORROSIVE VAPORS IS NOT COVERED BY WARRANTY. (Refer to the limited warranty for complete terms and conditions).

G. REMOVING A BOILER FROM A COMMON VENT SYSTEM

⚠ DANGER

Do not install the boiler into a common vent with any other appliance. This will cause flue gas spillage or appliance malfunction, resulting in possible substantial property damage, severe personal injury, or death.

⚠ DANGER

Failure to follow all instructions can result in flue gas spillage and carbon monoxide emissions, causing severe personal injury or death.

When removing an existing boiler, the following steps must be followed.

1. Seal any unused openings in the common venting system.
2. Visually inspect the venting system for proper size and horizontal pitch to determine if there is blockage, leakage, corrosion or other deficiencies that could cause an unsafe condition.
3. If practical, close all building doors, windows and all doors between the common venting system and other spaces in the building. Turn on clothes dryers and any appliances not connected to the common venting system. Turn on any exhaust fans, such as range hoods and bathroom exhausts, at maximum speed. Do not operate a summer exhaust fan. Close all fireplace dampers.
4. Place in operation the appliance being inspected. Follow

⚠ WARNING

Breathing Hazard - Carbon Monoxide Gas

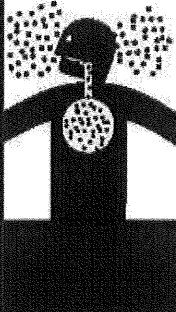

- Do not operate heater if flood damaged.
- Install vent system in accordance with local codes and manufacturers installation instructions.
- Do not obstruct heater air intake or exhaust. Support all vent piping per manufacturers installation instructions.
- Do not place chemical vapor emitting products near unit.
- According to NFPA 720, carbon monoxide detectors should be installed outside each sleeping area.
- Never operate the heater unless it is vented to the outdoors.
- Analyze the entire vent system to make sure that condensate will not become trapped in a section of vent pipe and therefore reduce the open cross sectional area of the vent.

Breathing carbon monoxide can cause brain damage or death. Always read and understand instruction manual.

LP304 4/28/09

Figure 5 - CO Warning Label

the lighting instructions. Adjust the thermostat so the appliance will operate continuously.

5. Test for spillage at the draft hood relief opening after 5 minutes of main burner operation. Use the flame of a match or candle or smoke from a cigarette.

6. After it has been determined that each appliance remaining connected to common venting system properly vents when tested as outlined, return doors, windows, exhaust fans, fireplace dampers and any other gas burning appliance to their previous condition of use.

7. Any improper operation of the common venting system should be corrected so the installation conforms to the National Fuel Gas Code, ANSI Z223.1. When resizing any portion of the common venting system, the common venting system should be resized to approach the minimum size as determined using the appropriate tables in Appendix G in the National Fuel Gas Code, ANSI Z 223.1.

H. UNCRATING THE BOILER

⚠ WARNING

UNCRATING BOILER – Any claims for damage or shortage in shipment must be filed immediately against the transportation company by the consignee.

CAUTION

Cold weather handling – If boiler has been stored in a very cold location (below 0°F) before installation, handle with care until the plastic components come to room temperature.

Remove all sides of the shipping crate to allow the boiler to be lifted into its installation location. The boiler is also equipped with leveling feet that can be used to level the boiler properly on an uneven location surface. If surface flooring is rough, take care when sliding boiler into position, as you could catch the leveling feet and damage the boiler.

PART 4 – BOILER PIPING

CAUTION

Never use dielectric unions or galvanized steel fittings when connecting to a stainless steel storage tank or boiler. Failure to do so could result in property damage.

⚠ WARNING

The National Standard Plumbing Code, the National Plumbing Code of Canada, and the Uniform Plumbing Code limit heat transfer fluid pressure to less than the minimum working pressure of the potable water system up to 30 PSI maximum. In addition, the heat transfer fluid must be water or another non-toxic fluid having a toxicity of Class 1, as listed in Clinical Toxicology of Commercial Products, 5th Edition. Failure to follow this warning could result in property damage, severe personal injury, or death.

Plumbing of this product should only be done by a qualified, licensed plumber in accordance with all local plumbing codes. The boiler may be connected to an indirect water heater to supply domestic hot water. HTP offers indirect water heaters in a wide range of gallon sizes in either stainless steel or glass-lined construction.

A. RELIEF VALVE

Connect discharge piping to a safe disposal location following the guidelines in the following statement.

⚠ WARNING

To avoid water damage or scalding due to relief valve operation:

- Discharge line must be connected to relief valve outlet and run to a safe place of disposal. Terminate the discharge line in a manner that will prevent possibility of severe burns or property damage should the relief valve discharge.
- Discharge line must be as short as possible and the same size as the valve discharge connection throughout its entire length.
- Discharge line must pitch downward from the valve and terminate at least 6" above the floor drain, making discharge clearly visible.
- Discharge line shall terminate plain, not threaded, with a material serviceable for temperatures of 375°F or greater.
- Do not pipe discharge to any location where freezing could occur.
- No shutoff valve may be installed between the relief valve and boiler or in the discharge line. Do not plug or place any obstruction in the discharge line.
- Test the operation of the relief valve after filling and pressurizing the system by lifting the lever. Make sure the valve discharges freely. If the valve fails to operate correctly, replace it with a new relief valve.
- Test relief valve at least once annually to ensure the waterway is clear. If valve does not operate, turn the boiler "off" **and call a plumber immediately.**
- Take care whenever operating relief valve to avoid scalding injury or property damage.
- For boilers installed with only a pressure relief valve, the separate storage vessel must have a temperature and pressure relief valve installed. This relief valve shall comply with *Relief Valves for Hot Water Supply Systems, ANSI Z21.22 CSA4.4.*

FAILURE TO COMPLY WITH THE ABOVE GUIDELINES COULD RESULT IN FAILURE OF RELIEF VALVE OPERATION, RESULTING IN POSSIBILITY OF SUBSTANTIAL PROPERTY DAMAGE, SEVERE PERSONAL INJURY, OR DEATH.

B. GENERAL PIPING INFORMATION

CAUTION

The building piping system must meet or exceed the piping requirements in this manual.

CAUTION

Use a two wrench method when tightening piping onto the boiler connections: One wrench to prevent the appliance piping from twisting / turning. Failure to do so could result in damage to the appliance or its components. Damage due to improper installation IS NOT covered by warranty.

CAUTION

The control module uses temperature sensors to provide both high limit protection and modulating temperature control. The control module may also provide low water protection (through the addition of an optional kit) by sensing the water level in the heat exchanger. An optional flow switch may be installed on the supply of the system to activate the boiler when there is enough flow. Some codes/jurisdictions may require additional external controls.

C. BACKFLOW PREVENTER

Use a backflow preventer specifically designed for hydronic boiler installations. This valve should be installed on the cold water fill supply line per local codes (see Piping Details, Section J).

CAUTION

All piping methods shown in this manual use primary/secondary connection to the boiler loop. This is to avoid the possibility of inadequate flow through the boiler. For other piping methods, consult your HTP representative or refer to separate Piping Details, Section J, in this manual.

D. SYSTEM WATER PIPING METHODS

EXPANSION TANK AND MAKE-UP WATER

1. Ensure that the expansion tank is designed and sized to correctly handle system water volume and temperature.

EXPANSION TANK SIZING

EL-80	1.4 Gallons
EL-110	1.7 Gallons
EL-150	2.0 Gallons
EL-220	2.6 Gallons
EL-299	3.1 Gallons
EL-399	3.7 Gallons

Table 2

CAUTION

Undersized expansion tanks cause system water to be lost from the relief valve, causing make-up water to be added. Eventual boiler failure can result due to excessive make-up water addition. **SUCH FAILURE IS NOT COVERED BY WARRANTY.**

2. The expansion tank must be located as shown in Part 4, Boiler Piping, or following recognized design methods. See expansion tank manufacturer's instructions for details.
3. Connect the expansion tank to the air separator only if the air separator is on the suction side of the circulator. Always install the system fill connection at the same point as the expansion tank connection to the system.
4. Most chilled water systems are piped using a closed type expansion tank.

⚠ CAUTION

DO NOT install automatic air vents on closed type expansion tank systems. Air must remain in the system and return to the tank to provide an air cushion. An automatic air vent would cause air to leave the system, resulting in improper operation of the expansion tank.

DIAPHRAGM (OR BLADDER) EXPANSION TANK

Always install an automatic air vent on top of the air separator to remove residual air from the system.

E. CIRCULATORS

⚠ CAUTION

DO NOT install automatic air vents on closed type expansion tank systems. Air must remain in the system and return to the tank to provide an air cushion. An automatic air vent would cause air to leave the system, resulting in improper operation of the expansion tank.

▲ CAUTION

DO NOT use the boiler circulator in any location other than the ones shown in this manual. The boiler circulator location is selected to ensure adequate flow through the boiler. Failure to comply with this caution could result in unreliable performance and nuisance shutdowns from insufficient flow.

Sizing Space Heat System Piping

1. See Piping Details in this manual, Section G. In all diagrams, the space heating system is isolated from the boiler loop by the primary/secondary connection.
2. Size the piping and components in the space heating system using recognized design methods.

F. HYDRONIC PIPING WITH CIRCULATORS, ZONE VALVES, AND MULTIPLE BOILERS

This boiler is designed to function in a closed loop hydronic system. We have included a temperature and pressure gauge that allows the user to monitor the system pressure and outlet temperature from the boiler. It is important to note that the boiler has a minimal amount of pressure drop that must be calculated when sizing the circulators. Unless the system has a closed type expansion tank, each boiler installation must have an air elimination device that will remove air from the system.

Install the boiler so the gas ignition system components are protected from water (dripping, spraying, etc.) Allow clearance for basic service of boiler circulator, valves and other components.

Observe the minimum 1" clearance around all uninsulated hot water pipes when openings around pipes are not protected by non-combustible materials.

On a boiler installed above radiation level, some states and local codes require a low water cut off device, which is an optional part available through HTP (Part # 7450P-225). Check with local codes for additional requirements. If the boiler supplies hot water to heating coils in air handler units, flow control valves or other devices must be installed to prevent gravity circulation of boiler water in the coils during the cooling cycle.

Chilled water medium must be piped in parallel with the boiler. Freeze protection for new or existing systems must use glycol that is specifically formulated for this purpose. Antifreeze must include inhibitors that will prevent the glycol from attacking the metallic system components. Make certain that the system fluid is checked for the correct glycol concentration and inhibitor level. The system should be tested at least once a year and as recommended by the producer of the glycol solution. Allowance should be made for the expansion of the glycol solution in the system piping. Example: 50% by volume glycol solution expands 4.8% in volume for a temperature increase from 32°F to 180°F, while water expands 3% with the same temperature rise.

G. PIPING DETAILS*

***NOTE:** Systems shown are primary/secondary piping systems. These recommended systems have a primary (boiler) loop, and secondary circuits for heating. The primary loop and secondary circuits have separate circulators. The use of other near boiler piping configurations could result in improper flow rates, leading to inadvertent boiler high limit shutdowns and poor system performance.

CAUTION

Mixing valves are required for the protection of low temperature loops.

NOTE: In piping applications utilizing a single zone, it is recommended that the installer use flow / check valves with weighted seats at or near the appliance to prevent gravity circulation.

Single Elite Heating Boiler® Space Heating with Indirect Priority

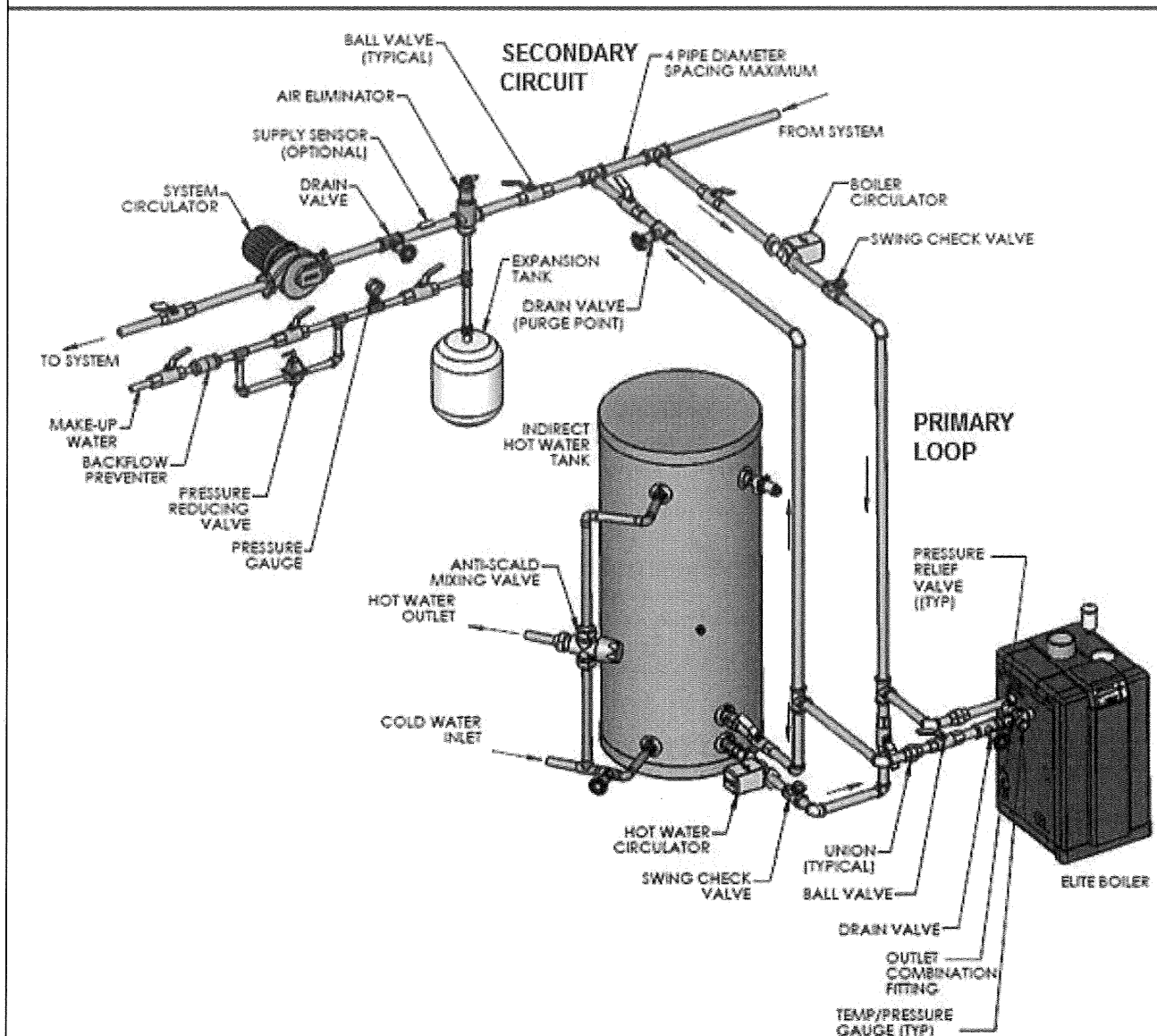

Figure 6 – LP-293-L NOTES:

1. This drawing is meant to show system piping concept only.
2. A mixing valve is recommended if the DHW temperature is set above 119°F.
3. Install a minimum of 12 diameters of straight pipe upstream of all circulators.
4. Piping shown is Primary/Secondary.
5. System flow (secondary loop) should be greater than the boiler primary loop flow. In all cases, the boiler primary loop flow rate must be maintained above the minimum flow rates published on p. 28, this manual.
6. Installations must comply with all local codes.
7. In Massachusetts, a vacuum relief valve must be installed in the cold water line per 248 CMR.

Cascade Multiple Elite Heating Boiler® with Indirect Priority on One Boiler

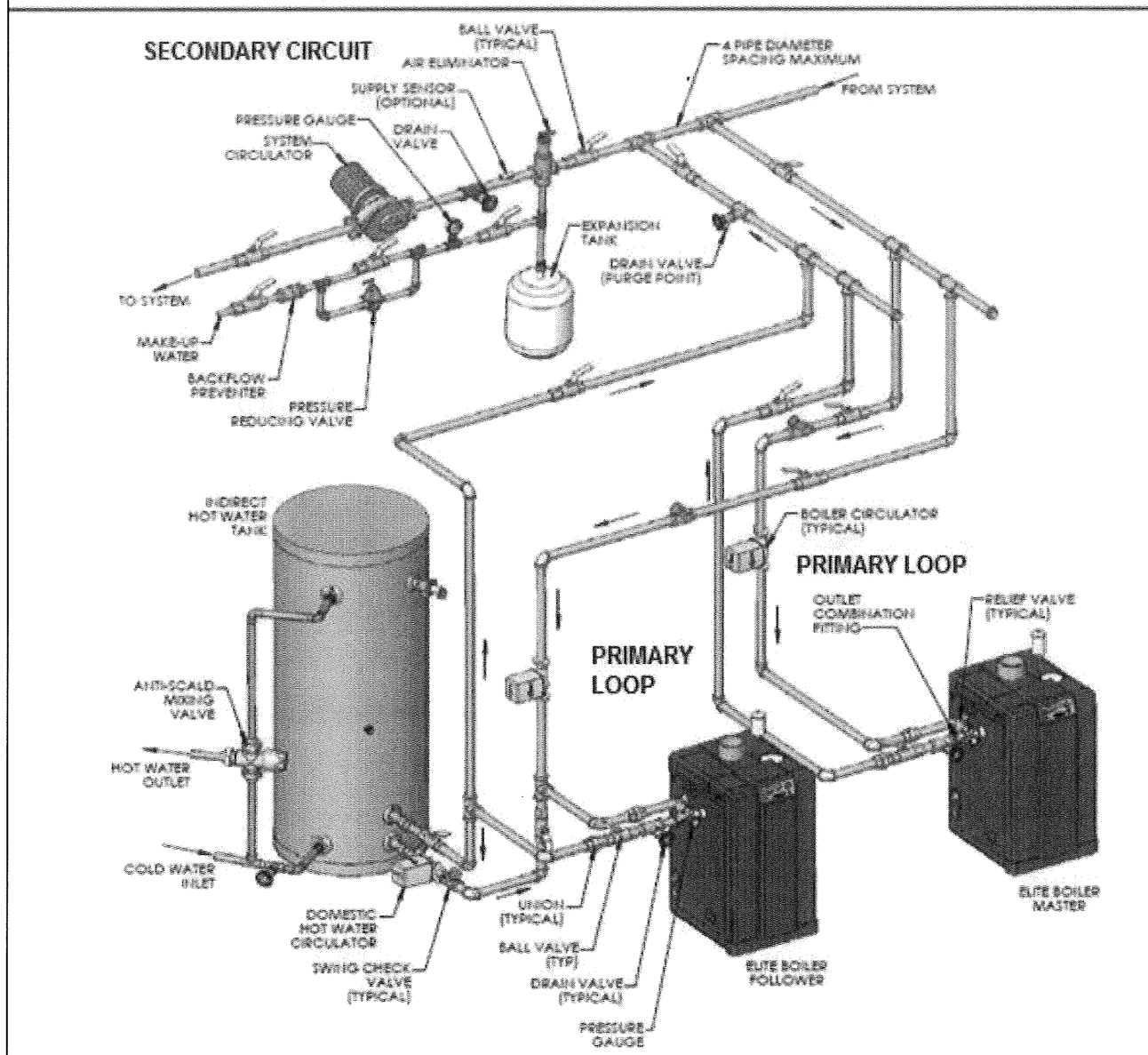

Figure 7 – LP-293-Q

NOTES:

1. This drawing is meant to show system piping concept only.
2. A mixing valve is recommended if the DHW temperature is set above 119°F.
3. Install a minimum of 12 diameters of straight pipe upstream of all circulators.
4. Piping shown is Primary/Secondary.
5. System flow (secondary loop) should be greater than the boiler primary loop flow. In all cases, the boiler primary loop flow rate must be maintained above the minimum flow rates published on p. 28, this manual.
6. Installations must comply with all local codes.
7. In Massachusetts, a vacuum relief valve must be installed in the cold water line per 248 CMR.
8. Reference Figure 10 to determine manifold pipe sizing.

Single Elite Heating Boiler® Space Heating

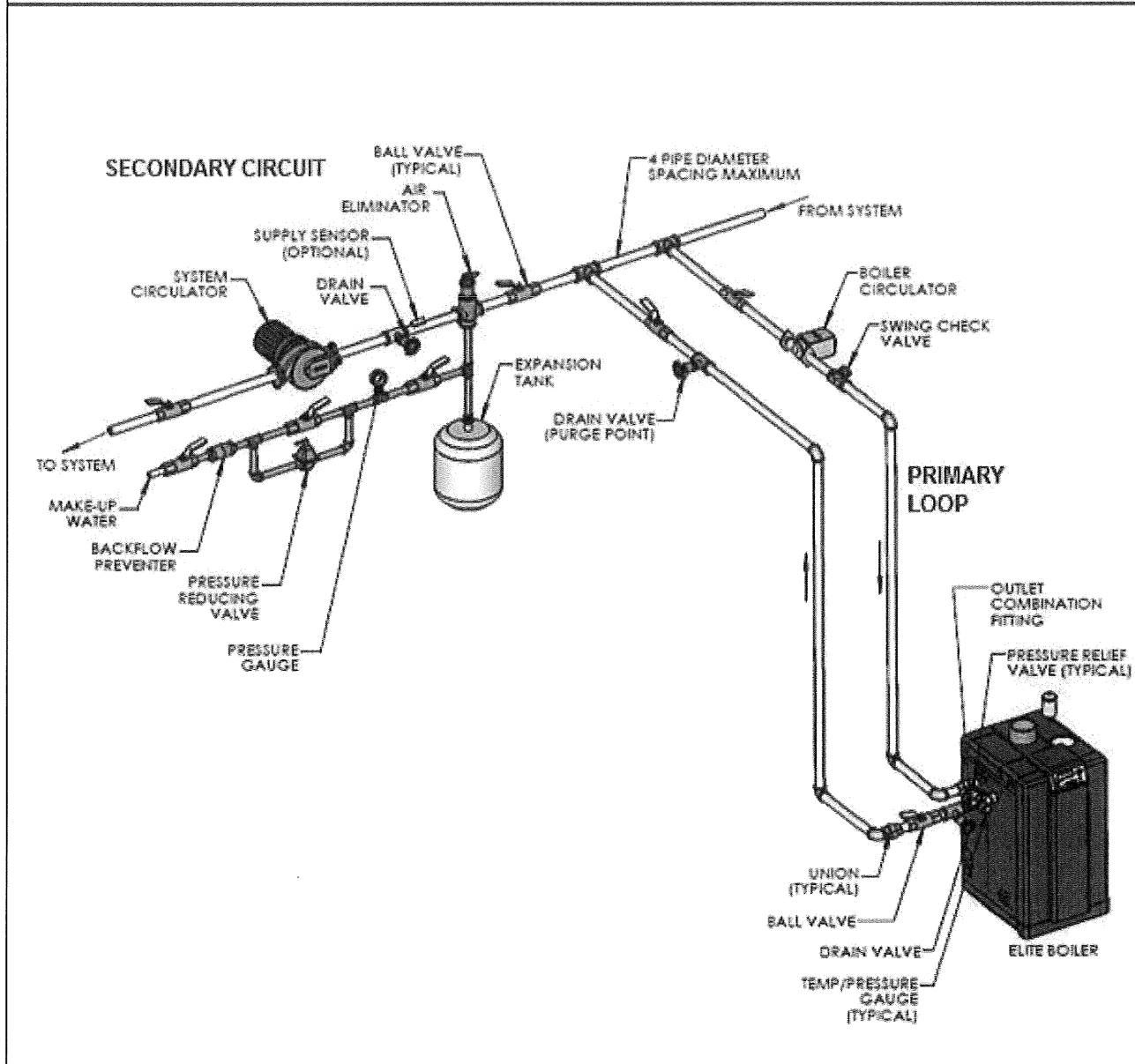

Figure 8 – LP-293-O

NOTES:

1. This drawing is meant to show system piping concept only.
2. Install a minimum of 12 diameters of straight pipe upstream of all circulators.
3. Piping shown is Primary/Secondary.
4. System flow (secondary loop) should be greater than the boiler primary loop flow. In all cases, the boiler primary loop flow rate must be maintained above the minimum flow rates published on p. 28, this manual.
5. Installations must comply with all local codes.

Cascade Elite Heating Boilers® Space Heating Only

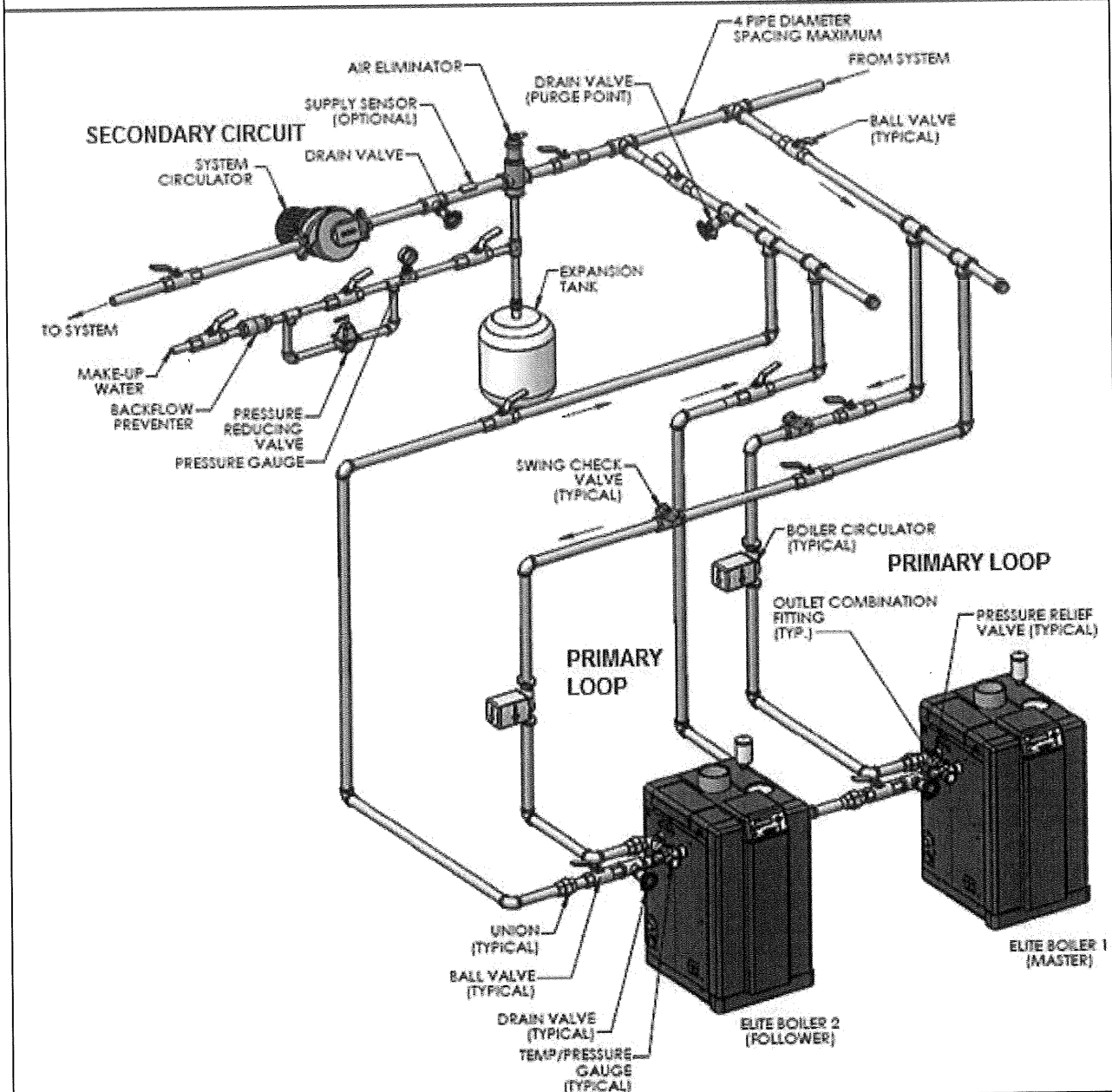

Figure 9 – LP-293-P

NOTES:

1. This drawing is meant to show system piping concept only.
2. Install a minimum of 12 diameters of straight pipe upstream of all circulators.
3. Piping shown is Primary/Secondary.
4. System flow (secondary loop) should be greater than the boiler primary loop flow. In all cases, the boiler primary loop flow rate must be maintained above the minimum flow rates published on p. 28, this manual.
5. Installations must comply with all local codes.

H. PIPING INSTALLATION

CAUTION

This boiler should not be operated as a potable hot water heater. It should not be used as a direct hot water heating device.

Basic steps are listed below that will guide you through the installation of the boiler.

1. Connect the system return marked "Boiler Return".
2. Connect the system supply marked "Boiler Supply".
3. Install a purge and balance valve or shut off valve and drain on the system return to purge air out of each zone.
4. Install a back flow preventer on the cold feed make-up water line.
5. Install a pressure reducing valve on the cold feed make-up water line (15 psi nominal on the system return). This boiler has a maximum working pressure of 160 psi. You may order a higher pressure relief valve kit from the factory. Check temperature and pressure gauge when operating. It should read a minimum pressure of 12 psi.
6. Install a circulator as shown in piping details (this section). Make sure the circulator is properly sized for the system and friction loss.
7. Install an expansion tank on the system supply (see Part 4, Section D for water volume). Consult the expansion tank manufacturer's instructions for specific information relating to expansion tank installation. Size the expansion tank for the required system volume and capacity.
8. Install an air elimination device on the system supply.
9. Install a drain valve at the lowest point of the system. NOTE: The boiler cannot be drained completely of water without purging the unit with an air pressure of 15 psi.
10. The relief valve and temperature and pressure gauge are included in the boiler accessory kit. A pipe discharge line should be installed 6" above the drain in the event of pressure relief. The pipe size must be the same size as the relief valve outlet. **NEVER BLOCK THE OUTLET OF THE SAFETY RELIEF VALVE.**

I. CIRCULATOR SIZING

The heat exchanger has a pressure drop that must be considered in your system design. Refer to Table 3 for pressure drop through the heat exchanger.

HEAT EXCHANGER PRESSURE DROP CHART																			
Model	Flow Rate Δ P'																		
Flow Rate	2 GPM	3 GPM	4 GPM	5 GPM	6 GPM	7 GPM	8 GPM	9 GPM	10 GPM	11 GPM	12 GPM	13 GPM	14 GPM	15 GPM	16 GPM	17 GPM	18 GPM	19 GPM	20 GPM
EL-80	2.5'	3'	4'	7'	10'	14'	17'	21'	26'	*	*	*	*	*	*	*	*	*	*
EL-110	*	3'	4'	7'	9'	12'	15'	17'	22'	25'	33'	*	*	*	*	*	*	*	*
EL-150	*	*	3'	4'	5'	6'	9'	10'	12'	15'	17'	19'	22'	27'	*	*	*	*	*
EL-220	*	*	*	*	*	2'	2'	3'	4'	5'	5.5'	6'	12'	8'	10'	11.5'	13'	15'	16.5'
EL-299	*	*	*	*	*	*	3'	3.5'	4'	4.5'	5'	6'	7'	8'	8.75'	9.25'	10.25'	11'	13'
EL-399	*	*	*	*	*	*	*	*	*	*	*	3.8'	4'	5'	6'	6.6'	7'	7.8'	8.3'
Flow Rate	21 GPM	22 GPM	23 GPM	24 GPM	25 GPM	26 GPM	27 GPM	28 GPM	29 GPM	30 GPM	31 GPM	32 GPM	33 GPM	34 GPM	35 GPM	36 GPM	37 GPM	38 GPM	39 GPM
EL-80	*	*	*	*	*	*	*	*	*	*	*	*	*	*	*	*	*	*	*
EL-110	*	*	*	*	*	*	*	*	*	*	*	*	*	*	*	*	*	*	*
EL-150	*	*	*	*	*	*	*	*	*	*	*	*	*	*	*	*	*	*	*
EL-220	17'	19'	21'	23'	24'	*	*	*	*	*	*	*	*	*	*	*	*	*	*
EL-299	14'	15'	16.5'	18'	20'	22'	24'	26'	29'	33'	36'	*	*	*	*	*	*	*	*
EL-399	9.2'	9.7'	10.3'	11.1'	12'	12.9'	13.6'	14'	15.7'	17'	18'	19.4'	21'	22.5'	26'	28'	31'	34'	39'

Table 3 – NOTE: *Do not operate boiler at these flow settings as it will damage the heat exchanger or related components.

The chart below represents the various system design temperature rise through the boiler along with their respective flows and friction loss, which will aid in circulator selection.

SYSTEM TEMPERATURE RISE CHART										
Model	20°Δt		25°Δt		30°Δt		35°Δt		40°Δt	
	Ft / Friction	Flow Rate	Ft / Friction	Flow Rate	Ft / Friction	Flow Rate	Ft / Friction	Flow Rate	Ft / Friction	Flow Rate
EL-80	17'	8 GPM	10'	6.6 GPM	7'	5.3 GPM	7'	4.6 GPM	4'	4 GPM
EL-110	25'	11 GPM	17'	9.1 GPM	12'	7.3 GPM	9'	6.4 GPM	8.2'	5.5 GPM
EL-150	27'	15 GPM	17'	12.5 GPM	12'	10 GPM	10'	8.8 GPM	8.8'	7.5 GPM
EL-220	19'	22 GPM	13'	18.3 GPM	12'	14.6 GPM	6'	12.8 GPM	5'	11 GPM
EL-299	29'	29 GPM	18'	24.5 GPM	13'	20 GPM	9.5'	17.3 GPM	8'	14.5 GPM
EL-399	39'	39 GPM	19'	32.5 GPM	13'	26 GPM	10'	22.8 GPM	8'	19.5 GPM

Table 4

The chart on the following page represents the combined flow rates and pipe sizes when using multiple boilers to design the manifold system for the primary circuit. To size, simply add up the number of boilers and the required flow rates for the system design temperature.

Example: (5) EL-220 Boilers® with a design of 20°Δt degree temperature rise with each boiler having an individual flow rate of 22 GPM. To correctly size the manifold feeding these (5) boilers you would need a pipe size of 4".

MULTIPLE BOILER MANIFOLD PIPING																					
Flow Rate (GPM)	16	22	24	30	32	33	40	44	45	48	50	55	60	66	75	80	85	88	90	100	110
Pipe Dia. (Inches)	2	2	2	2	2	2½	2½	2½	2½	2½	2½	2½	2½	2½	3	3	3	3	3	3	4

Table 5

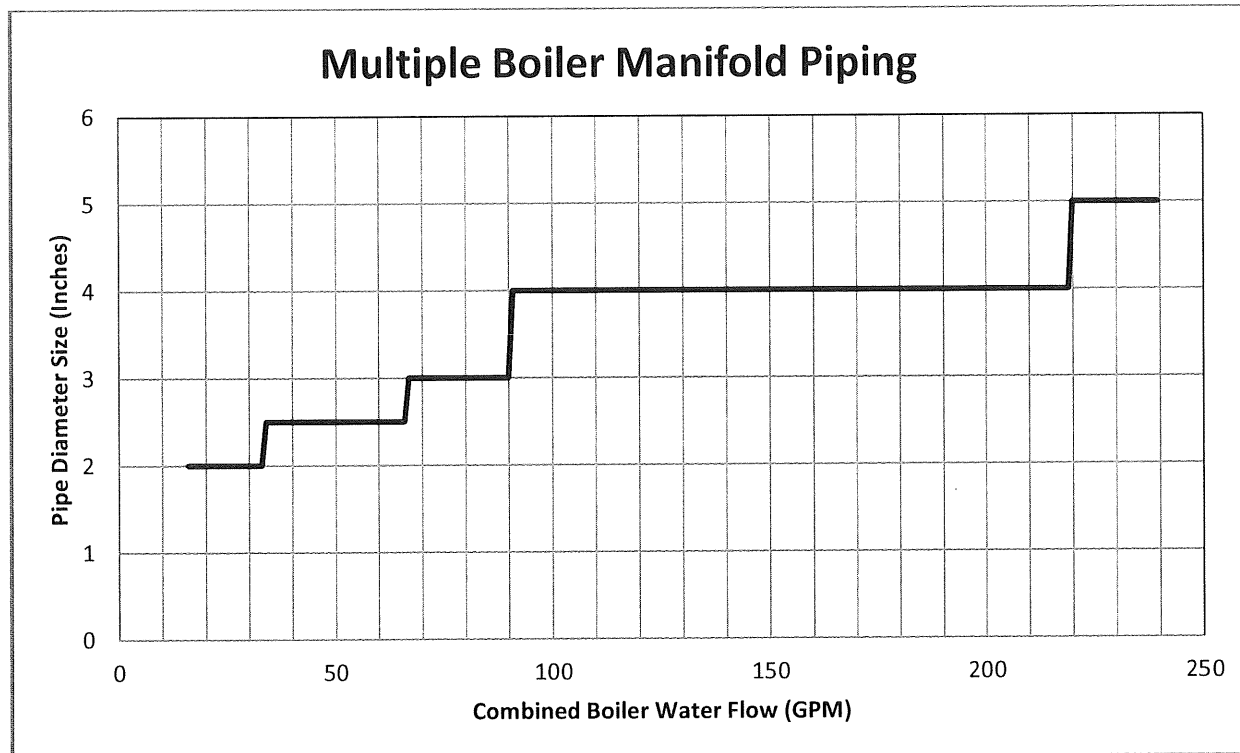

Figure 10

MULTIPLE BOILER MANIFOLD PIPING																				
Flow Rate (GPM)	120	132	150	160	170	179	200	210	239	240	250	255	300	340	350	400	425	510	595	680
Pipe Dia. (In.)	4	4	4	4	4	4	4	4	5	5	5	5	5	5	5	5	5	6	6	6

Table 6

J. CHECK/CONTROL WATER CHEMISTRY

NOTE: BOILER FAILURE DUE TO IMPROPER WATER CHEMISTRY IS NOT COVERED BY WARRANTY.

Sodium less than 20 mGL

Water pH between 6.0 and 8.0

1. Maintain boiler water pH between 6.0 and 8.0. Check with litmus paper or have chemically analyzed by water treatment company.

2. If pH differs from above, consult local water treatment company for treatment needed.

Hardness less than 7 grains

Consult local water treatment companies for unusually hard water areas (above 7 grains hardness).

Chlorine concentration less than 200 ppm

1. Filling with chlorinated fresh water should be acceptable since drinking water chlorine levels are typically less than 5 ppm.
2. Do not use the boiler to directly heat swimming pool or spa water.
3. Do not fill boiler or operate with water containing chlorine in excess of 200 ppm.

Clean system to remove sediment*

1. You must thoroughly flush the system (without boiler connected) to remove sediment. The high-efficiency heat exchanger can be damaged by buildup or corrosion due to sediment.
2. For zoned systems, flush each zone separately through a purge valve. (If purge valves and isolation valves are not already installed, install them to properly clean the system.)
3. Flush system until water runs clean and you are sure piping is free of sediment.

***NOTE:** It is recommended you clean heat exchanger at least once a year to prevent lime scale buildup. Follow the maintenance procedure to clean the heat exchanger in the Maintenance Section (Part 12 of this manual).

Test/replace freeze protection fluid

1. For systems using freeze protection fluids, follow fluid manufacturer's instructions to verify inhibitor level and that other fluid characteristics are satisfactory.
2. Freeze protection fluid must be replaced periodically due to degradation of inhibitors over time. Follow all fluid manufacturer instructions.

Piping components

Heating system piping:

Water boiler system piping **MUST** be sized per technical pipe requirements listed in Table 5 and Table 6. Reducing pipe size can restrict flow rate through the water boiler, causing inadvertent short cycling and poor system performance.

Check valves:

Field supplied. Check valves are recommended for installation as shown in Piping Details.

Water boiler isolation valves:

Field supplied. Full port ball valves are required. Failure to use full port ball valves could result in a restricted flow rate through the water boiler.

Mixing valve:

Field supplied. A mixing valve is recommended when storing domestic hot water above 115°F.

Unions:

Field supplied: Recommended for unit serviceability. **DO NOT USE DIELECTRIC UNIONS! ONLY BRASS, COPPER, OR STAINLESS STEEL.**

Pressure relief valve:

Factory supplied on Boiler. The pressure relief valve is sized to ASME specifications. Storage tank may require additional relief valves depending on local codes.

MINIMUM PIPE SIZES	
EL 80, EL 110, EL 150, EL 220	1" NPT or Copper
EL 299	1 ¼" NPT or Copper
EL 399	1 ½" NPT or Copper

Table 7

K. FILL AND PURGE HEATING SYSTEM

1. Attach the hose to balance and purge hose connector or drain valve and run hose to nearest drain.
2. Close the other side of the balance and purge valve or shut off valve after the drain.
3. Open the first zone balance and purge or drain valve to let water flow out of the hose. If zone valves are used, open the valves one at a time manually. NOTE: You should check zone valve manufacturer's instructions prior to opening valves manually, so as not to damage the zone valve.
4. Manually operate fill valve regulator. When water runs out of the hose, you will see a steady stream without bubbles. Close the balance and purge valve or drain to stop the water from flowing. Disconnect the hose and connect it to next zone to be purged.
5. Repeat this procedure for additional zones (one at a time).

CAUTION

For installations that incorporate standing iron radiation and systems with manual vents at the high points, follow the previous section and, starting with the nearest manual air vent, open the vent until water flows out. Then close the vent. Repeat the procedure, working your way toward the furthest air vent. It may be necessary to install a basket strainer in an older system where larger amounts of sediment may be present. Annual cleaning of the strainer may be necessary.

Upon completion, make sure that the fill valve and zone valves are in automatic positions. You must also assure the purge and shut off valves are in open positions.

L. GLYCOL ANTIFREEZE SOLUTIONS

WARNING

Use only inhibited propylene glycol solutions which are specially formulated for hydronic systems. Ethylene glycol is toxic and can attack gaskets and seals used in hydronic systems. Glycol mixtures should not exceed 50%.

- Glycol in hydronic applications should include inhibitors that prevent the glycol from attacking metallic system components. Make certain that the system fluid is checked for the correct glycol concentration and inhibitor level.
- The glycol solution should be tested at least once a year or as recommended by the glycol manufacturer.
- Anti-freeze solutions expand more than water. For example: A 50% by volume solution expands 4.8% in volume for a temperature increase from 32°F to 180°F, while water expands 3% over the same temperature rise. Allowances must be made in system design for expansion.
- A 30% mixture of glycol will result in a BTU output loss of 15% with a 5% increase in head against the system circulator.
- A 50% mixture of glycol will result in a BTU output loss of 30% with a 50% increase in head against the system circulator.

CAUTION

It is highly recommended that you carefully follow the glycol manufacturer's recommended concentrations, expansion requirements, and maintenance recommendations (pH additive breakdown, inhibitor reduction, etc.) You must carefully calculate the additional friction loss in the system as well as the reduction in heat transfer coefficients.

M. ZONING WITH ZONE VALVES

1. When zoning with zone valves, connect the boiler to the system as shown in Piping Details, Part 4, Section G. The primary/secondary piping shown ensures the boiler loop will have sufficient flow. It also avoids applying the high head of the boiler circulator to the zone valves.
2. Connect DHW (domestic hot water) piping to indirect storage water heater as shown in Piping Details.

N. ZONING WITH CIRCULATORS

1. When using circulator zoning, connect the boiler to the system as shown in Piping Details, Part 4, Section G. **NOTE:** The boiler circulator cannot be used for a zone. It must only supply the boiler loop.
2. Install a separate circulator for each zone.
3. Connect DHW (domestic hot water) piping to indirect storage water heater as shown in Piping Details.

O. MULTIPLE BOILERS

1. Connect multiple boilers as shown in Piping Details, Part 4, Section G.
2. All piping shown is reverse return to assure balanced flow throughout the connected boilers.
3. Each connected boiler must have its own circulator pump to assure adequate flow.
4. Connect DHW (domestic hot water) piping to indirect storage water heater as shown in Piping Details.
5. The system flow (secondary loop) must be greater than the boiler's primary loop flow.

PART 5 – VENTING, COMBUSTION AIR, AND CONDENSATE REMOVAL** DANGER**

The heater must be vented as detailed in this Venting Section. Ensure exhaust and intake piping complies with these instructions regarding vent system. Inspect finished combustion air intake and exhaust piping thoroughly to ensure all joints are well secured, airtight, and comply with all applicable code requirements, as well as with the instructions provided in this manual. Failure to properly install the vent system will result in severe personal injury or death.

A. GENERAL** DANGER**

This vent system will operate with positive pressure in the pipe. Do not connect vent connectors serving appliances vented by natural draft into any portion of mechanical draft systems operating under positive pressure. Follow these venting instructions carefully. Failure to do so will result in substantial property damage, severe personal injury, or death.

1. Install the venting system in accordance with these instructions and with the National Fuel Gas Code, ANSI Z223.1/NFPA 54, CAN/CGA B149, and/or applicable provisions of local building codes.

2. This boiler is a direct vent appliance and is listed as a Category IV appliance with Underwriters Laboratories, Inc. VENT AND INTAKE AIR VENT.

3. This boiler must be vented with materials, components, and systems listed and approved for Category IV appliances.

B. APPROVED MATERIALS FOR EXHAUST AND INTAKE AIR VENTS

APPROVED VENTING MATERIAL			
Item	Material	Standards for Installation in:	
		United States	Canada
Vent or air pipe and fittings	PVC schedule 40/80	ANSI/ASTM D1785	CPVC and PVC venting must be ULC-S636 Certified. IPEX is an approved manufacturer in Canada, supplying vent material listed to ULC-S636.
	PVC-DWV	ANSI/ASTM D2665	
	CPVC schedule 40/80	ANSI/ASTM F441	
	Polypropylene	ULCS636	
	Stainless Steel AL29-4C	Certified for Category IV and direct vent appliance venting	Certified for Category IV and direct vent appliance venting
Pipe cement/primer	PVC	ANSI/ASTM D2564	IPEX System 636 Cements & Primers
	CPVC	ANSI/ASTM F493	

Table 8

⚠ DANGER

- Do NOT use Foam Core Pipe in any portion of the exhaust piping from this water heating appliance.
- DO NOT connect different types of plastic piping together.
- When installing AL29-4C vent piping, install a PVC-to-stainless adapter at the boiler vent connection, and at the termination when using an HTP PVC termination kit. DO NOT mix piping from different manufacturers unless using adapters specifically designed for the purpose by the manufacturer.

Failure to follow these directions will result in substantial property damage, severe personal injury, or death.

⚠ WARNING

DO NOT mix components from different systems. The vent system could fail, causing leakage of flue products into the living space. Use only the approved pipe and fitting materials, and primer and cement specifically designed for the material used, as listed in Table 8. Failure to do so could result in property damage, severe personal injury, or death.

⚠ WARNING

The exhaust vent adaptors included with these products are not designed as load-bearing devices, and must not be used to support exhaust vent piping. All vent pipes must be glued, properly supported, and the exhaust must be pitched a minimum of ¼" per foot back to the boiler to allow drainage of condensate. Failure to properly support vent piping and follow the information in this statement could result in product damage, severe personal injury, or death.

C. REQUIREMENTS FOR INSTALLATION IN CANADA

1. Installations must be made with a vent pipe system certified to ULC-S636. IPEX is an approved vent manufacturer in Canada supplying vent material listed to ULC-S636. Additionally you may use AL29-4C stainless steel venting to comply with Canadian requirements.

2. The first three (3) feet of vent pipe from the appliance flue outlet must be readily accessible for visual inspection.

3. The components of the certified vent system must not be interchanged with other vent systems or unlisted pipe / fittings.

Cellular foam core piping may be used on air inlet piping **only**.

NOTE: The use of double-wall vent or insulated material for the air inlet is recommended in cold climates to prevent the condensation of airborne moisture in the incoming combustion air.

⚠ DANGER

You must not use "B" vent in an exhaust application. "B" vent is for intake applications **ONLY**. Using "B" vent in an exhaust application will result in serious injury or death.

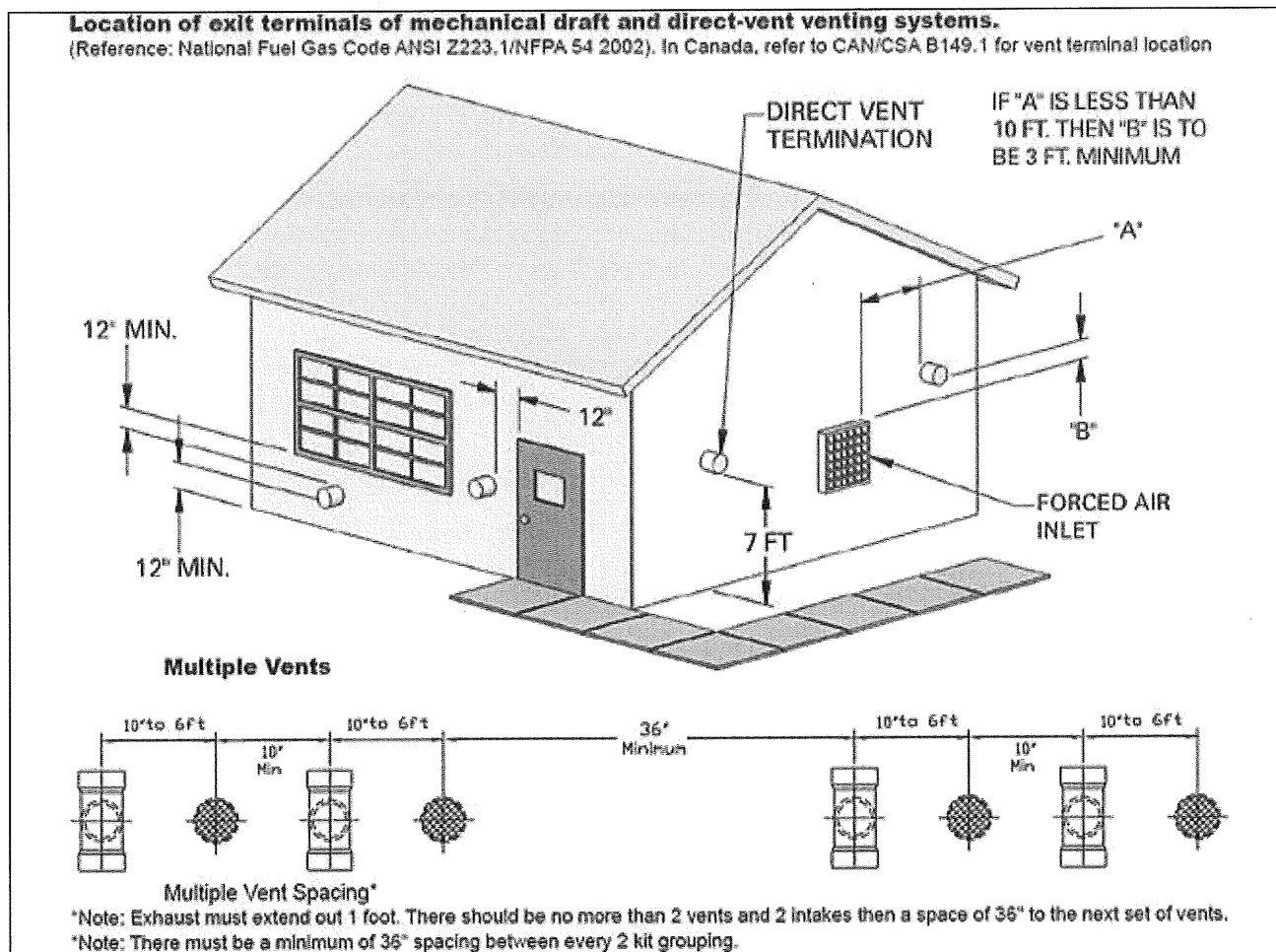

Figure 11 - NOTE: Drawing is meant to demonstrate system venting **ONLY**.

D. EXHAUST VENT AND INTAKE AIR VENT PIPE LOCATION

⚠ WARNING

You must insert the provided intake and exhaust screen at your vent termination to prevent blockage caused by debris or birds.

NOTE: SEE ADDITIONAL REQUIREMENTS FOR MASSACHUSETTS IN THE BACK OF THIS MANUAL.

1. Determine exhaust vent location:

- Total length of vent may not exceed the limits specified in Part 5 Section E.
- The vent piping for this heater is approved for zero clearance to combustible construction.
- See Venting Details within this section of clearances for location of exit terminals of direct-vent venting systems.
- Avoid terminating exhaust vents near shrubs, air conditioners or other objects that will obstruct the exhaust stream.
- The flue products coming from the exhaust vent will create a large plume when the heater is in operation. Avoid venting in areas that will affect neighboring buildings or be considered objectionable.
- The heater vent system shall terminate at least 3 feet (0.9 m) above any forced air intake located within 10 ft (3 m). **NOTE:** This does not apply to the combustion air intake of a direct-vent appliance.
- Provide a minimum of 1 foot distance from any door, operable window, or gravity intake into any building.
- Provide a minimum of 1 foot clearance from the bottom of the exhaust above the expected snow accumulation level. Snow removal may be necessary to maintain clearance.
- Provide 4 feet horizontal clearance from electrical meters, gas meters, gas regulators, relief equipment, exhaust fans and inlets. In no case shall the exit terminal be above or below the aforementioned equipment unless the 4 foot horizontal distance is maintained.
- Do not locate the heater exhaust over public walkways where condensate could drip and/or freeze and create a nuisance or hazard.
- When adjacent to a public walkway, locate exit terminals at least 7 feet above grade.
- To prevent icicles from forming, do not locate the exhaust directly under roof overhangs.
- Provide 6 feet of clearance from the inside corner of vertical walls, chimneys, etc., as well as horizontal corners created by roof overhangs.

2. Determine air intake vent location:

- Provide 1 foot of clearance from the bottom of the intake vent and the level of maximum snow accumulation. Snow removal may be necessary to maintain clearances.
- Do not locate the intake air vent in a parking area where machinery may damage the vent.
- Follow required minimum clearances located in Figure 11.

3. Determine location of condensate piping:

This heater is a high efficiency appliance, and therefore produces condensate: a by-product of the combustion process. A condensate collection system with an internal float switch monitors the condensate level to prevent it from backing up into the combustion system. There is a 3/4" socket connection provided to connect the outlet of the collection system to a drain or condensate pump.

4. Condensate neutralization

Condensate from the heater is slightly acidic with a pH of 3.2 - 4.5. To avoid long term damage to the drainage system and to meet local code requirements, HTP recommends neutralizing the condensate with a Condensate Neutralizer Kit (Part # 7450P-212 for EL-80/110/150/220/299, Part # 7350P-611 for EL-399). The neutralizer kit connects to the drain system and contains limestone chips that neutralize the pH level of the water vapor. The neutralizer kit should be checked annually and the limestone chips replenished if necessary. When replacing the limestone chips, take care to ensure chips are no smaller than 1/2" to avoid blockage in condensate piping (refer to Figure 12 for piping of the condensate neutralizer.)

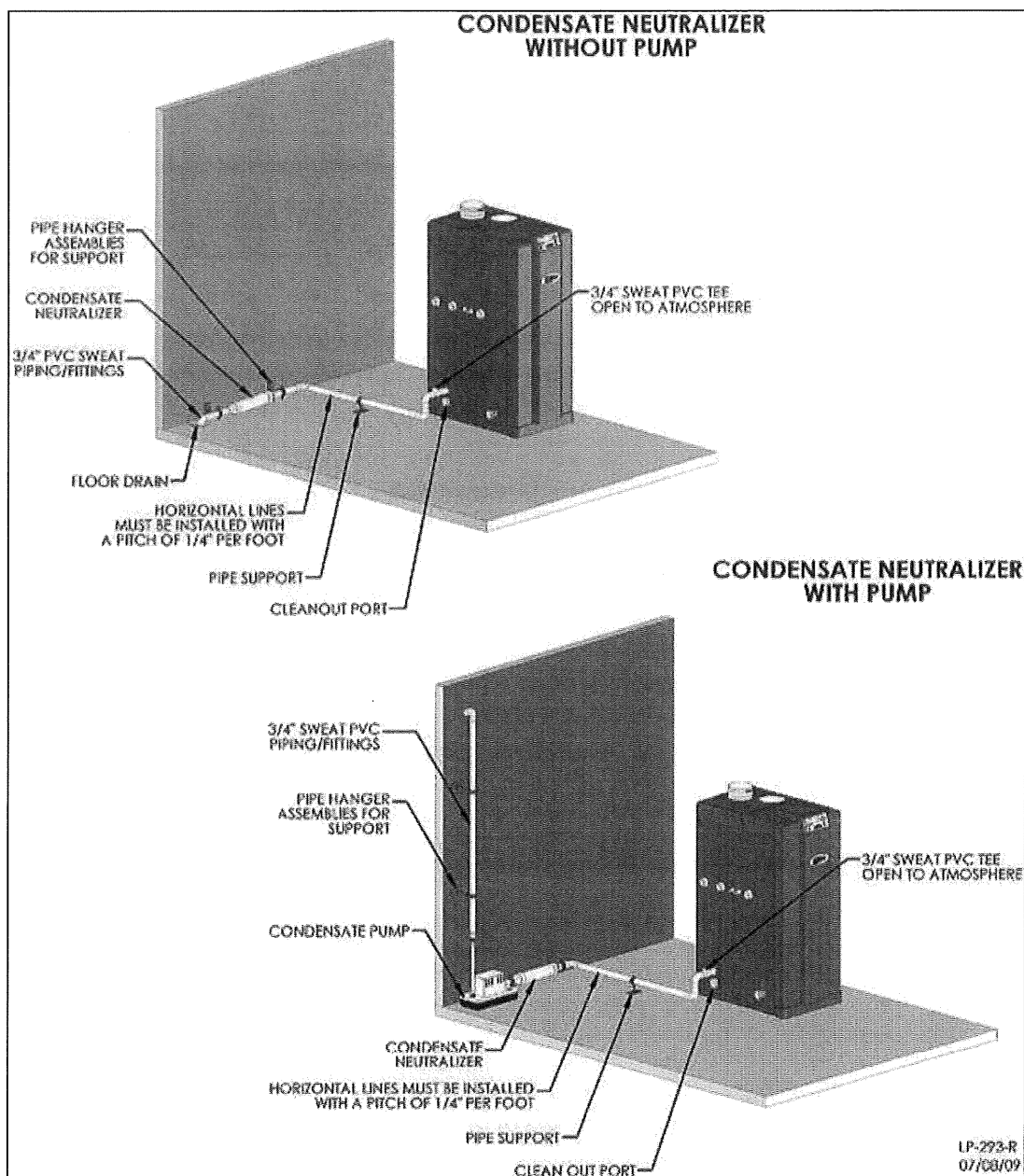

Figure 12 – Condensate Piping

NOTE: To clean out condensate collector, blow water into collector to remove any foreign matter that may block the condensate line.

⚠ WARNING

When servicing is complete, you must make sure this cap is replaced securely. Failure to do so will cause venting issues that will result in serious injury or death.

CAUTION

When installing a condensate pump, select one approved for use with condensing heaters and furnaces. The pump should have an overflow switch to prevent property damage from condensate spillage.

CAUTION

It is very important that the condensate piping be no smaller than $\frac{3}{4}$ ". You must use a tee at the condensate connection with a branch vertically up and open to the atmosphere, so as not to cause a vacuum that could obstruct the flow of condensate from the heater. To prevent sagging and maintain pitch, condensate piping should be supported with pipe supports.

CAUTION

The condensate line must remain unobstructed, allowing free flow of condensate. If condensate freezes in the line, or if line is obstructed in any other manner, condensate can exit from the tee, resulting in potential water damage to property.

NOTE: To allow for proper drainage on larger horizontal condensate runs, tubing size may need to increase to 1 inch and a second line vent may be required.

E. EXHAUST VENT AND INTAKE AIR VENT SIZING

1. The exhaust vent and intake air vent pipes are 3" for the Elite EL-80/110/155/220 and 4" for the EL-299/399.
2. The total combined equivalent length of exhaust vent and intake air pipe should not exceed 200 feet.
 - a. The equivalent length of friction loss in elbows, tees, and other fittings are listed in Table 9.

FRICTION LOSS EQUIVALENT FOR STAINLESS OR PLASTIC PIPING AND FITTINGS			
FITTING DESCRIPTION	3"	4"	6"
90° elbow short radius	5'	5'	3'
90° elbow long radius	4'	4'	3'
45° elbow	3'	3'	2'
Coupling	0'	0'	0'
Tee (intake only)	0'	0'	0'
V Series Vent Kit	1'	1'	1'
AL20 4C Vent Terminal	1'	1'	1'
Pipe (All Materials)	1'	1'	1'

Table 9 *Friction loss for long radius elbow is 1' less. NOTE: Consult Polypropylene venting instructions for friction loss and pressure drop equivalents.

b. For example: If the exhaust vent is 3" in diameter, and has two short 90° elbows and 10 feet of PVC pipe we will calculate: Exhaust Vent Pipe Equivalent Length = $(2 \times 5) + 10 = 20$ feet.

Further, if the 3" intake air vent pipe has two short 90° elbows, one 45° elbow, and 10 feet of PVC pipe, the following calculation applies: Intake Air Equivalent Length = $(2 \times 5) + 3 + 10 = 23$ feet.

Therefore, the total equivalent length equals 43 feet.

c. You should keep a minimum combined equivalent length between the intake air vent pipe and the exhaust vent. The minimum combined equivalent length is 32 combined equivalent feet.

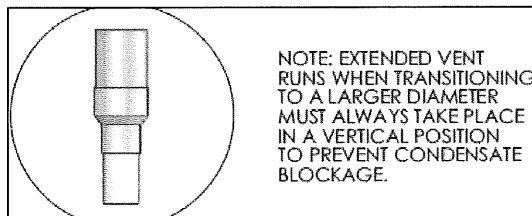

Figure 13

F. LONGER VENT RUNS

The maximum combined equivalent length can be extended by equally increasing the diameter of both the exhaust and intake air vent pipes. However, transitions should begin a minimum of 32 combined equivalent feet from the heater equally on both the intake and exhaust.

The maximum equivalent length for increased diameter vent pipes is 275 feet, which includes the combined 32 feet from the heater, 16 ft. (inlet) + 16 ft. (exhaust) = 32 ft. combined with transition total of 243 ft. upsizing piping for longer vent runs.

VENT TRANSITION FITTING		
SIZE	REDUCING COUPLING	FINAL VENT SIZE
3" Venting	4" x 3"	4"
4" Venting	6" x 4"	6"
6" Venting	8" x 6"	8"

Table 10

CAUTION

Do not exceed the maximum lengths for increased diameter vent pipes. Excessive length could result in appliance shutdown and property damage.

G. EXHAUST VENT AND INTAKE AIR PIPE INSTALLATION

⚠ WARNING

All joints of positive pressure vent systems must be sealed completely to prevent leakage of flue products into living space. Failure to do so could result in carbon monoxide leakage, property damage, severe personal injury, or death.

1. Use only solid PVC or CPVC pipe, or a Polypropylene vent system, approved for use with Category IV appliances. FOAM CORE PIPING IS NOT APPROVED FOR EXHAUST APPLICATIONS.
2. Remove all burrs and debris from joints and fittings.
3. When using PVC or CPVC pipe, all joints must be properly cleaned, primed, and cemented. Use only cement and primer approved for use with the pipe material. Cement must conform to ASTM D2564 for PVC and ASTM F493 for CPVC pipe. **NOTE: DO NOT CEMENT POLYPROPYLENE PIPE.**
4. Horizontal lengths of exhaust vent must slope back towards the water heater not less than ¼" per foot to allow condensate to drain from the vent pipe.
5. All piping must be fully supported. Use pipe hangers at a minimum of 4 foot intervals to prevent sagging of the pipe where condensate may form.
6. Do not use the heater to support any piping.
7. A screened straight coupling is provided with the heater for use as an outside exhaust termination.
8. A screened inlet air tee is provided with the heater to be used as an outside intake termination.

The following information on Table 11 lists optional intake air/exhaust vent terminations available from HTP:

DESCRIPTION	STOCK CODE
3" PVC CONCENTRIC VENT TERMINATION KIT	KGAVT0601CVT
3" STAINLESS STEEL VENT TERMINATION KIT	V1000
4" STAINLESS STEEL VENT TERMINATION KIT	V2000
6" STAINLESS STEEL VENT TERMINATION KIT	V3000
3" POLYPRO VENT KIT	8400P-001

Table 11

H. SIDEWALL VENTING

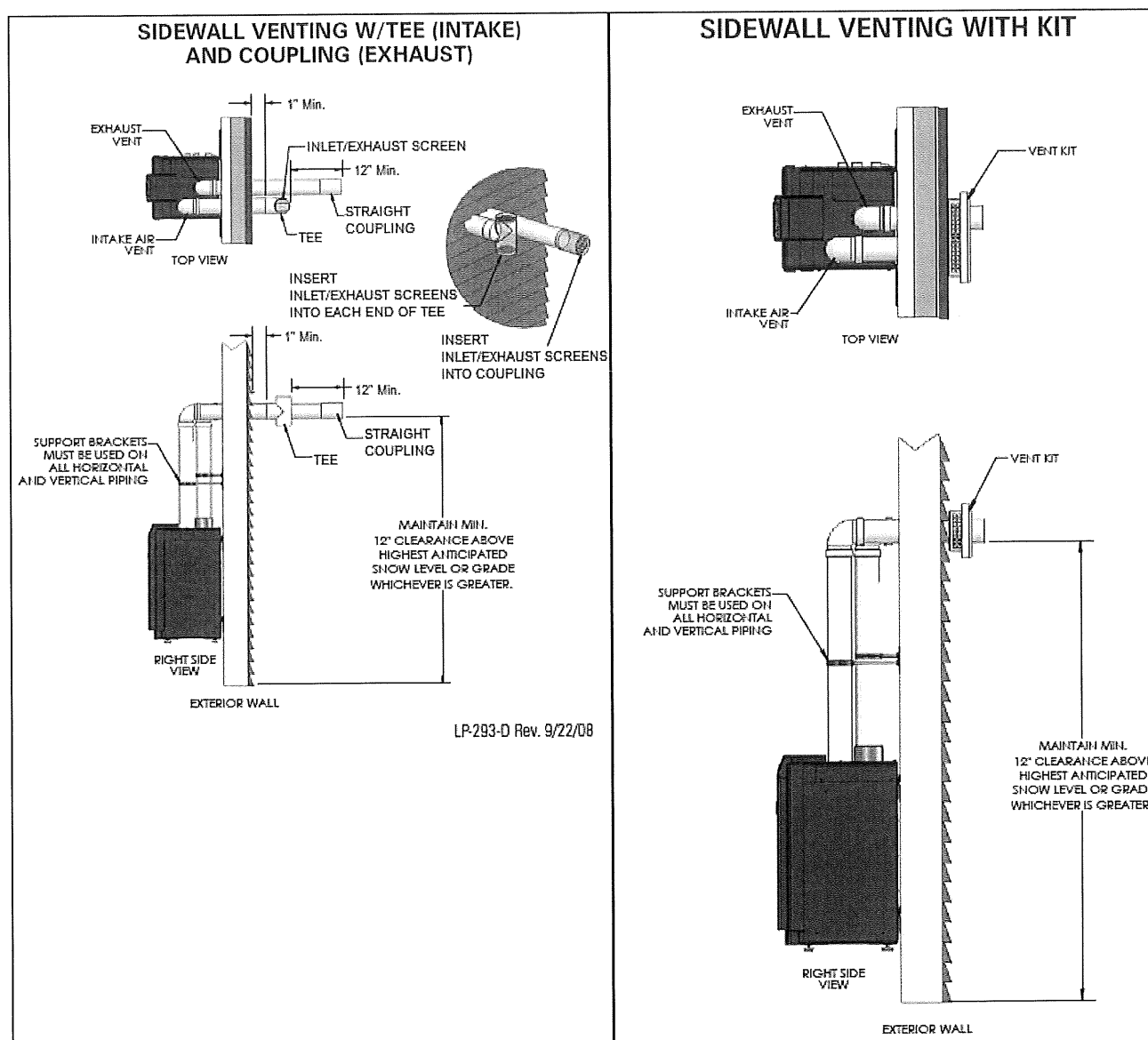

Figure 14 – Sidewall Venting with Tee (Intake) and Coupling (Exhaust) – LP-293-E

NOTE: Vent piping should be 12" over anticipated maximum snow level.

NOTE: Drawing is meant to demonstrate system venting ONLY.

⚠ WARNING

All vent pipes must be glued, properly supported, and the exhaust must be pitched a minimum of $\frac{1}{4}$ " per foot back to the boiler to allow drainage of condensate. When placing support brackets on vent piping, the first bracket must be within 1 foot of the boiler and the balance at 4 foot intervals on the vent pipe. Boiler venting must be readily accessible for visual inspection for the first three feet from the boiler.

I. VERTICAL VENTING

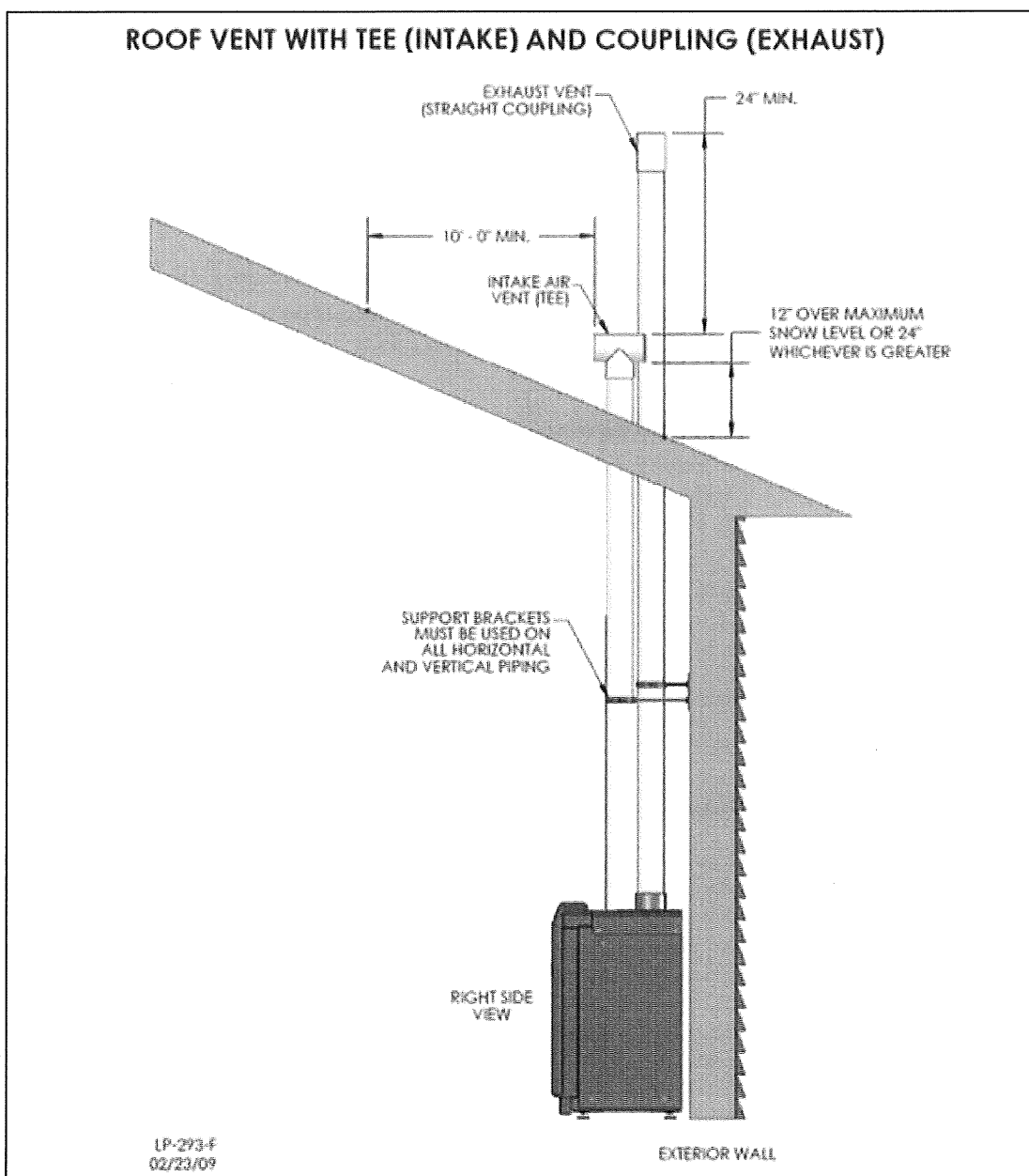

Figure 15 – Vertical Venting - LP-293-F

NOTE: Vent piping should be 12" over anticipated maximum snow level.

NOTE: Drawing is meant to demonstrate system venting ONLY.

⚠ WARNING

All vent pipes must be glued, properly supported, and the exhaust must be pitched a minimum of $\frac{1}{4}$ " per foot back to the boiler to allow drainage of condensate. When placing support brackets on vent piping, the first bracket must be within 1 foot of the boiler and the balance at 4 foot intervals on the vent pipe. Boiler venting must be readily accessible for visual inspection for the first three feet from the boiler.

J. HORIZONTAL VENTING

Figure 16 – Horizontal Venting - NOTE: Drawing is meant to demonstrate system venting ONLY.

NOTES:

- A. For every 1" of overhang, the exhaust vent must be located 1" vertical below overhang (overhang means top of building structure and not two adjacent walls [corner of building]).
- B. Typical installations require 12" minimum separation between bottom of exhaust outlet and top of air intake.
- C. Maintain 12" minimum clearance above highest anticipated snow level or grade (whichever is greater).
- D. Minimum 12" between vents when installing multiple vents.
- E. 12" minimum beyond air intake.

⚠ WARNING

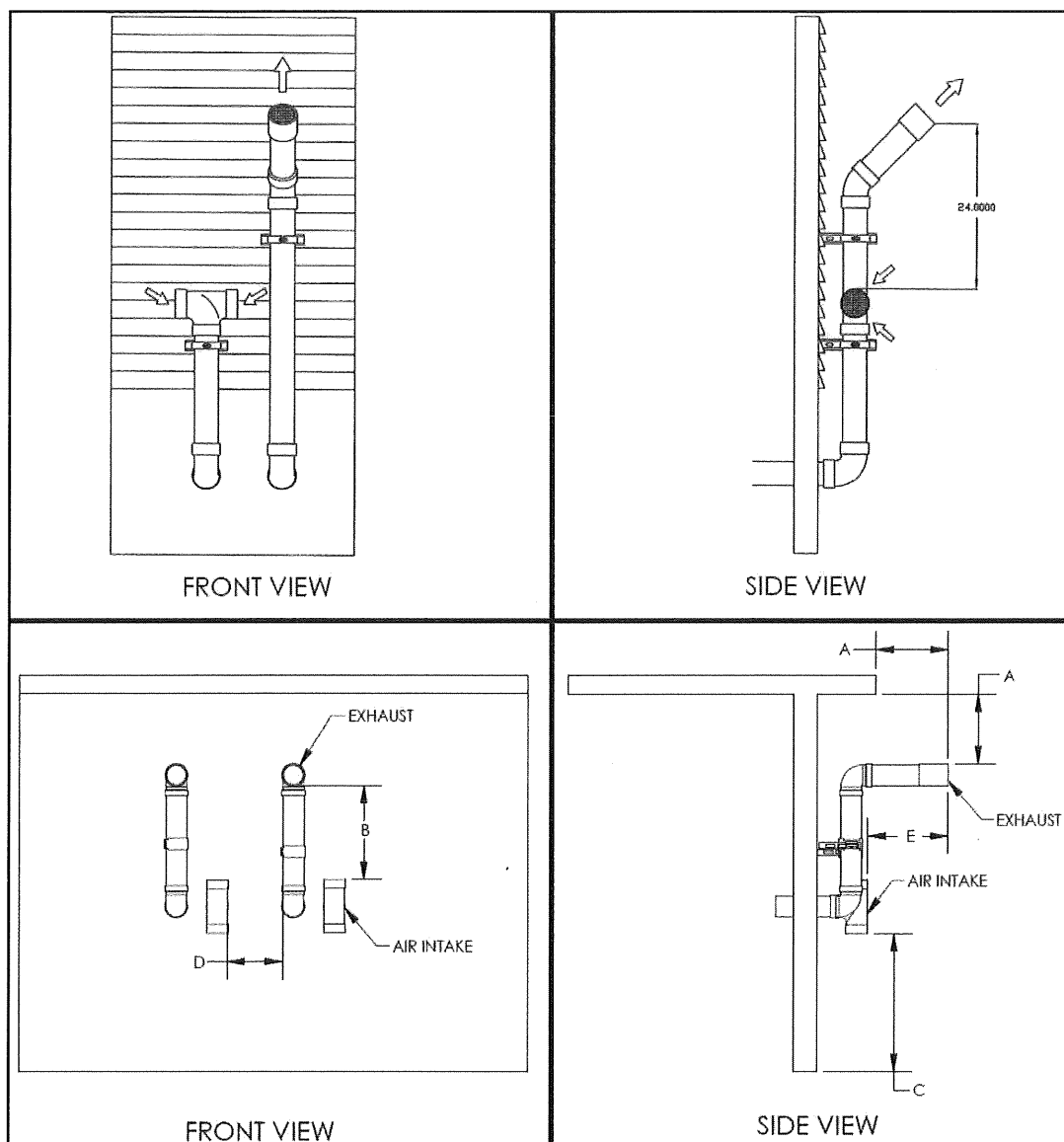
All vent pipes must be glued, properly supported, and the exhaust must be pitched a minimum of $\frac{1}{4}$ " per foot back to the boiler to allow drainage of condensate. When placing support brackets on vent piping, the first bracket must be within 1 foot of the boiler and the balance at 4 foot intervals on the vent pipe. Boiler venting must be readily accessible for visual inspection for the first three feet from the boiler.

K. UNBALANCED FLUE / VERTICAL VENT

Figure 17 – LP-293-T – Unbalanced Flue/Vertical Vent - NOTE: Drawing is meant to demonstrate system venting ONLY.

⚠ WARNING

All vent pipes must be glued, properly supported, and the exhaust must be pitched a minimum of $\frac{1}{4}$ " per foot back to the boiler to allow drainage of condensate. When placing support brackets on vent piping, the first bracket must be within 1 foot of the boiler and the balance at 4 foot intervals on the vent pipe. Boiler venting must be readily accessible for visual inspection for the first three feet from the boiler.

⚠ WARNING

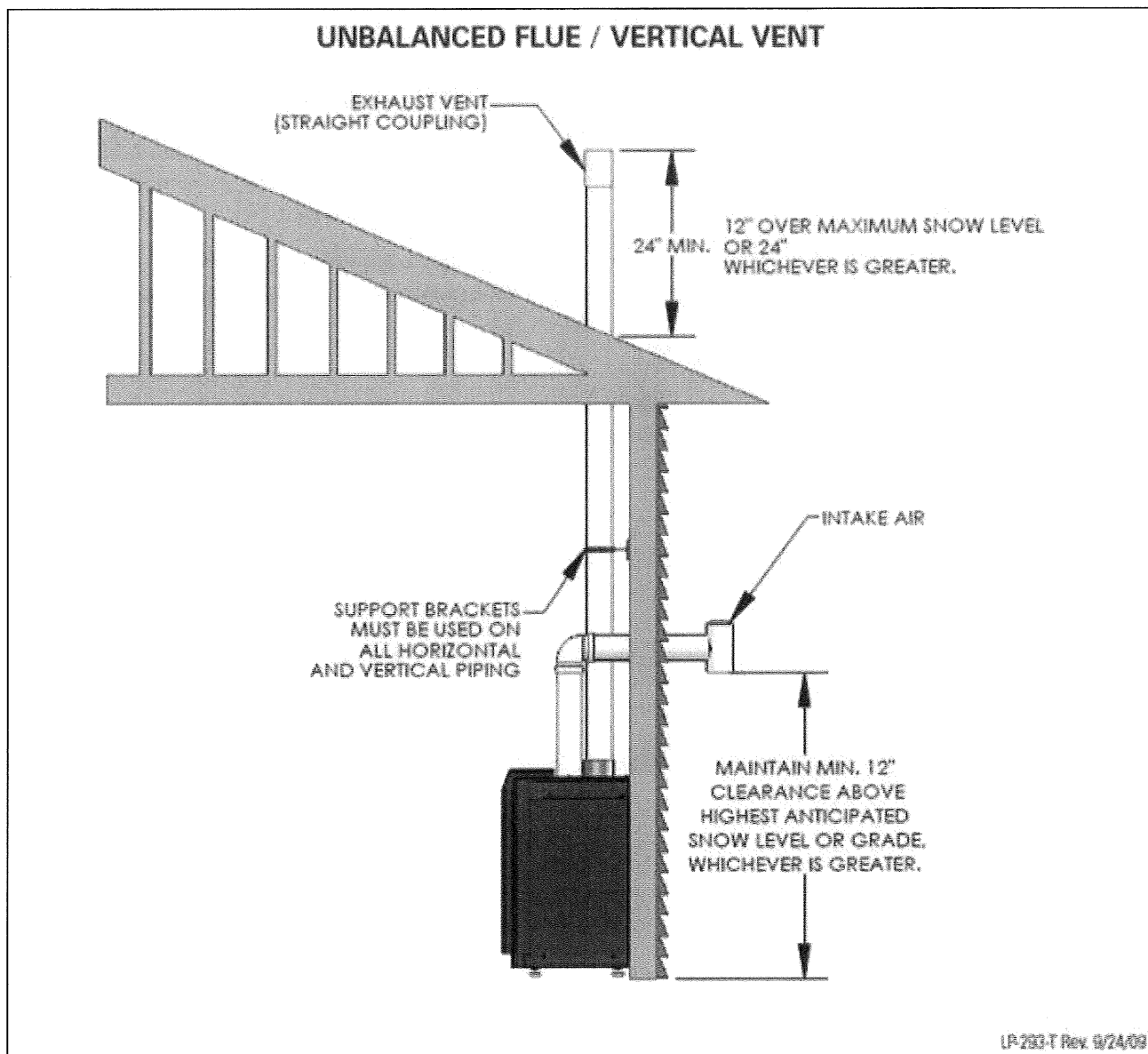
An unbalanced vent system can be installed ONLY when the exhaust is in a vertical position.

L. VENTING THROUGH AN EXISTING SYSTEM

This boiler may be vented through an existing unused vent system. The inner diameter of the existing vent system is utilized for the combustion air source. Two methods have been approved for such venting: Concentric Venting Through an Existing System and Venting as a Chase.

⚠ DANGER

Do not install the boiler into a common existing vent with any other appliance. This will cause flue gas spillage or boiler malfunction, resulting in substantial property damage, severe personal injury, or death.

CAUTION

Contractors must check state and local codes before installing through an existing vent opening. State and local codes always take precedence over manufacturer's instructions. Failure to check state and local codes before installing through an existing opening could result in property damage and add significantly to installation costs.

1. CONCENTRIC VENTING THROUGH AN EXISTING SYSTEM

NOTE: The following instructions refer only to venting through an existing vent system, and not to venting with HTP's concentric vent kits (2" Part # KGVAT0501CVT, 3" Part # KGAVT0601CVT). Refer to Concentric Vent Kit installation manual (Part # LP-166) for further concentric venting information and instructions.

Concentric venting through an existing system must run vertically through the roof. See Table 11 for proper minimum vent sizing. Use only the approved venting materials specified in Table 10 for piping the system. All instructions listed in Part 5 - Venting, Sections A – G apply. See Figures 18-1 and 18-2 for venting demonstrations.

⚠ DANGER

The upper and lower vent terminations as well as all joints in the venting system must be properly sealed to ensure that all combustion air is drawn properly and exhaust does not leak from the system. Failure to properly seal the venting system will result in property damage, severe personal injury, or death.

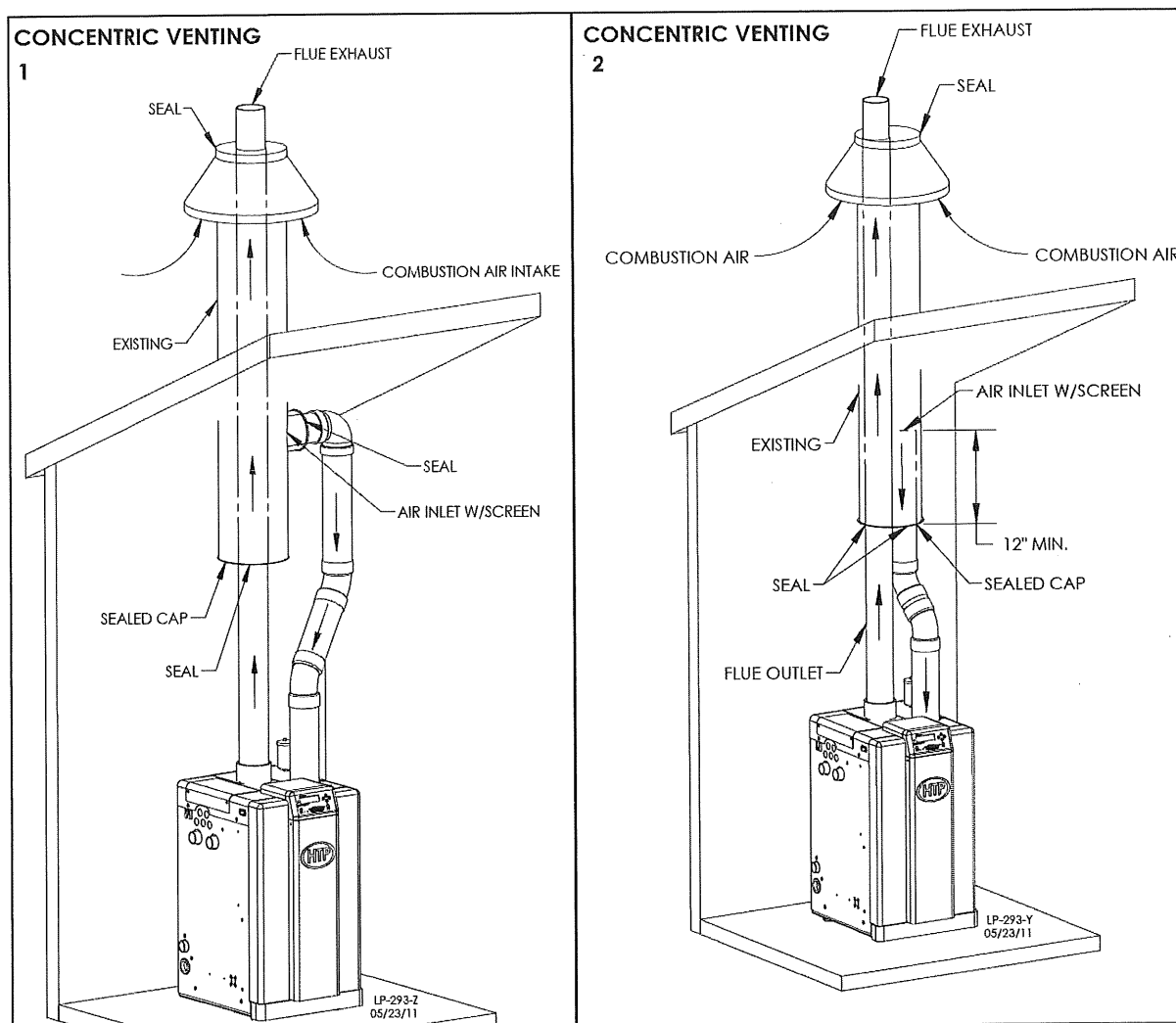

Figure 18 – 1, 18 – 2 Concentric Venting NOTE: Drawing is meant to demonstrate system venting ONLY.

NOTES:

- A. For every 1" of overhang, the exhaust vent must be located 1" vertical below overhang (overhang means top of building structure and not two adjacent walls [corner of building]).
- B. Typical installations require 12" minimum separation between bottom of exhaust outlet and top of air intake.
- C. Maintain 12" minimum clearance above highest anticipated snow level or grade (whichever is greater).
- D. Minimum 12" between vents when installing multiple vents.
- E. 12" minimum beyond air intake.
- F. Maintain 12" minimum clearance above highest anticipated snow level or grade (whichever is greater).

CAUTION

If an existing venting system is converted for use with this boiler, the installer must ensure that the existing venting system is clean and free from particulate contamination that could damage the boiler. Failure to do so could result in property damage and boiler failure. Such failure IS NOT covered under warranty.

VENT / AIR INLET SIZE	MINIMUM EXISTING VENT / CHASE SIZE
2"	4"
3"	5"
4"	7"

Table 12 – Minimum Vent / Chase Sizing

2. VENTING AS A CHASE

When venting as a chase, follow all instructions included in Part 5 – Venting, Sections A – G of this manual, as well as the previous Concentric Venting section. See Figure 19 for chase venting demonstration.

NOTES:

- A. For every 1" of overhang, the exhaust vent must be located 1" vertical below overhang (overhang means top of building structure and not two adjacent walls [corner of building]).
- B. Typical installations require 12" minimum separation between bottom of exhaust outlet and top of air intake.
- C. Maintain 12" minimum clearance above highest anticipated snow level or grade (whichever is greater).
- D. Minimum 12" between vents when installing multiple vents.
- E. 12" minimum beyond air intake.
- F. Maintain 12" minimum clearance above highest anticipated snow level or grade (whichever is greater).

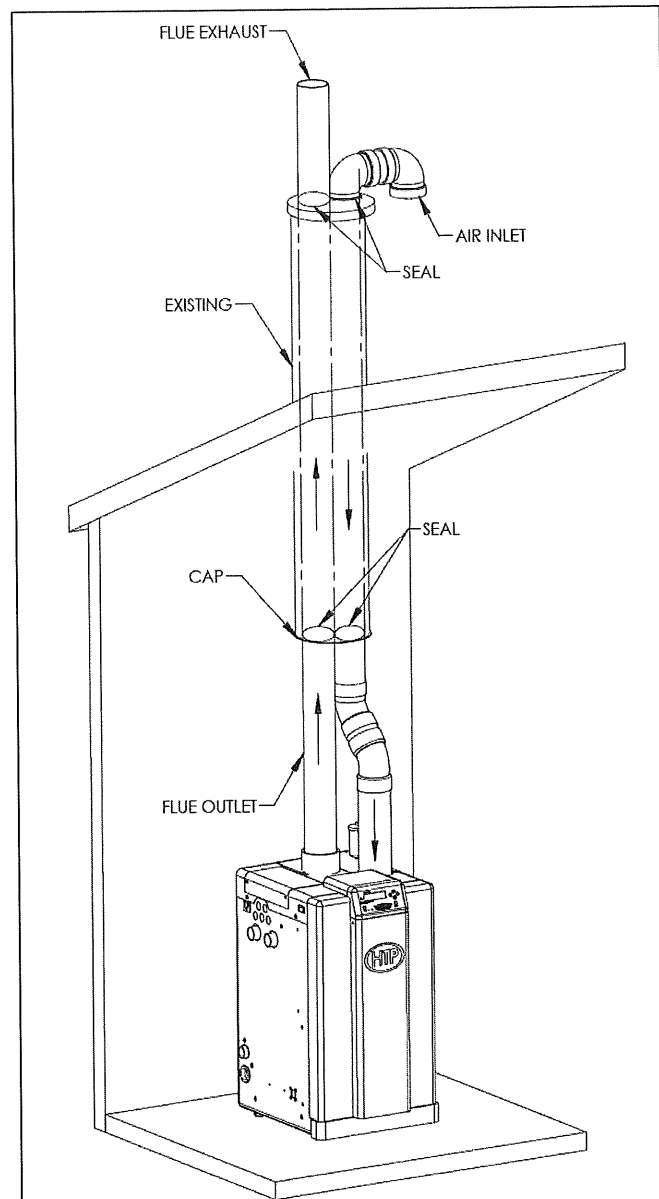

Figure 19 – Venting as a Chase

M. INDOOR COMBUSTION AIR INSTALLATION IN CONFINED OR UNCONFINED SPACE

NOTE: This installation is intended for commercial applications. For residential applications, it is recommended to pipe intake combustion air from the outdoors.

This boiler requires fresh, uncontaminated air for safe operation and must be installed in a mechanical room where there is adequate combustion and ventilating air. **NOTE: To prevent combustion air contamination, see Table 3.**

Combustion air from the indoor space can be used if the space has adequate area or when air is provided through a duct or louver to supply sufficient combustion air based on the boiler input. **Never obstruct the supply of combustion air to the boiler.** If the boiler is installed in areas where indoor air is contaminated (see Table 3) it is imperative that the boiler be installed as direct vent so that all combustion air is taken directly from the outdoors into the boiler intake connection.

Unconfined space is space with volume not less than 50 cubic feet per 1,000 Btu/hour (4.8 cubic meters per kW) of the total input rating of all fuel-burning boilers installed in that space. Rooms connected directly to this space, through openings not furnished with doors, are considered part of the space.

Confined space is space with volume less than 50 cubic feet per 1,000 Btu/hour (4.8 cubic meters per kW) of the total input rating of all fuel-burning boilers installed in that space. Rooms connected directly to this space, through openings not furnished with doors, are considered part of the space.

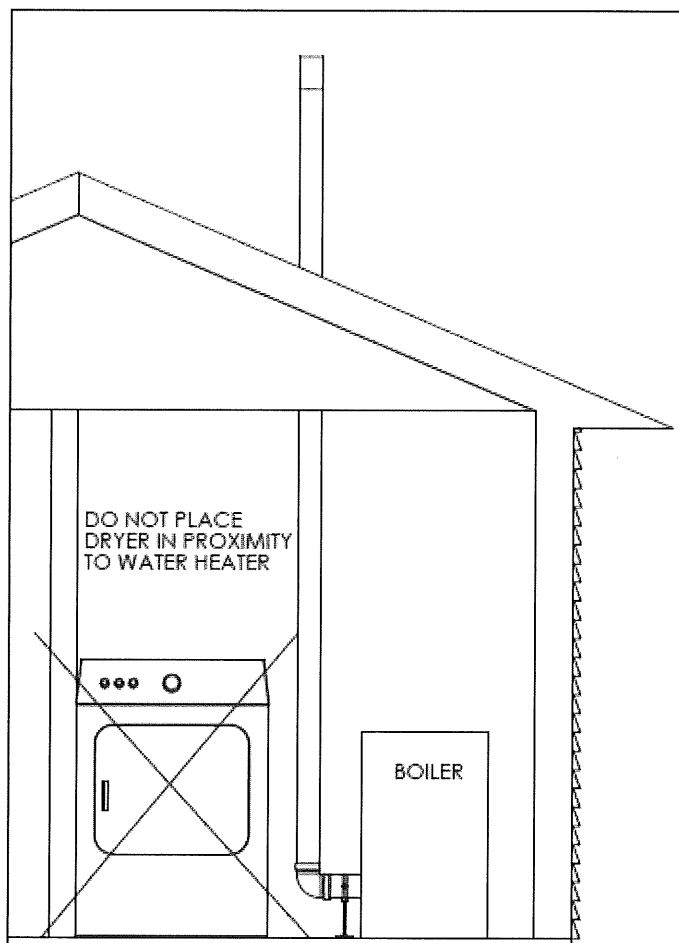

Figure 20 – LP-387-Z

When drawing combustion air from inside a conventionally constructed building to a confined space located on the same story, such space should be provided with two permanent openings: one located 6" (15 cm) below the space ceiling, the other 6" (15cm) above the space floor. Each opening should have a free area of one square inch per 1,000 Btu/hr (22cm²/kW) of the total input of all boilers in the space, but not less than 100 square inches (645cm²).

When drawing combustion air from inside a conventionally constructed building to a confined space located on different stories, such spaces should be considered as communicating spaces when connected with one or more permanent openings in doors or floors having a total minimum free area of two square inches per 1,000 Btu/hr (22cm²/kW) of the total input of all boilers in the space, but not less than 200 square inches (645cm²).

If the confined space is within a building of tight construction, air for combustion must be obtained from the outdoors as outlined in the Venting section of this manual.

NOTE: It is always recommended to isolate the boiler installation room from the rest of the building and bring uncontaminated air in from the outside for combustion and ventilation.

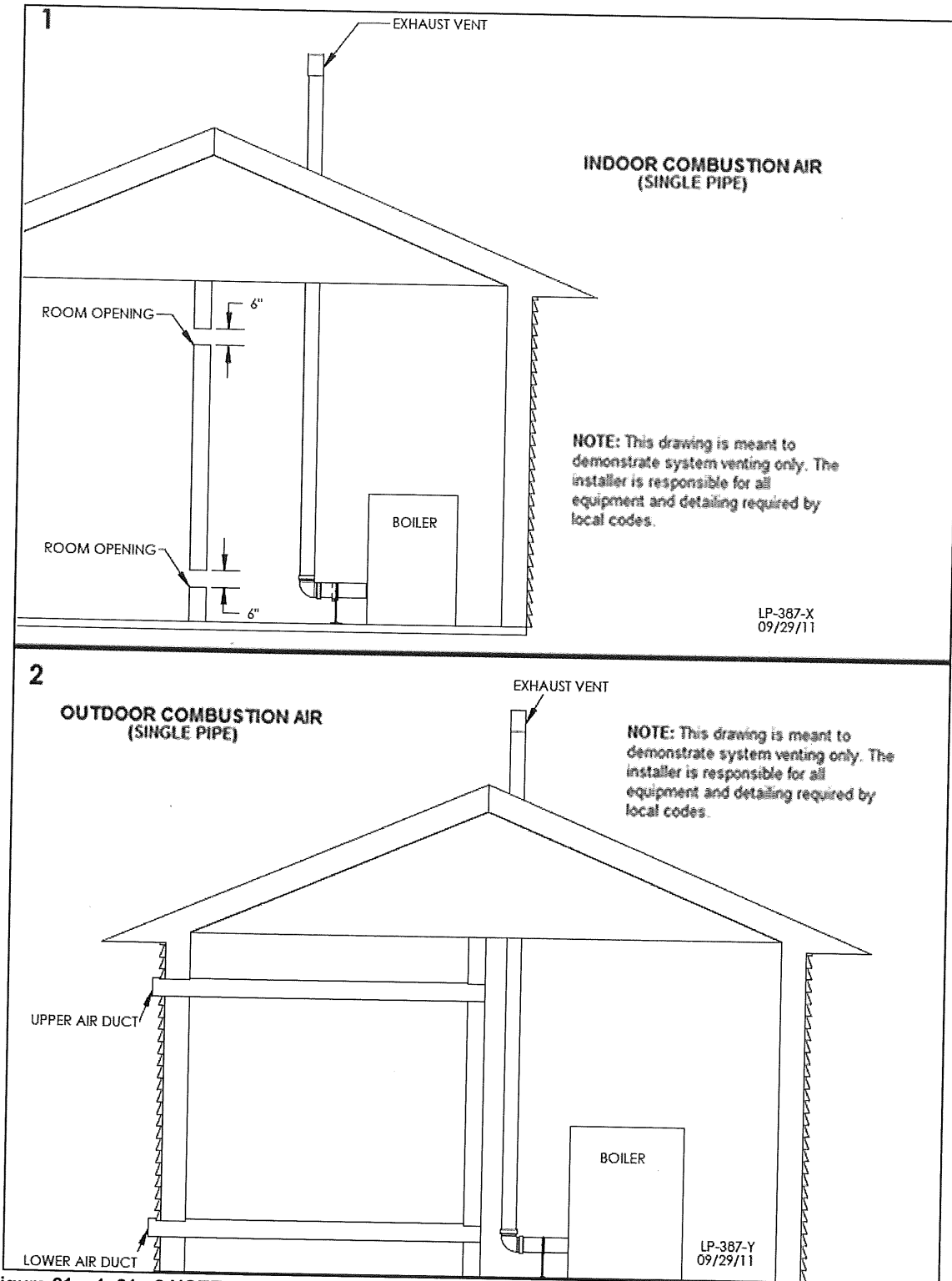

Figure 21 – 1, 21 - 2 NOTE: These drawings are meant to demonstrate system venting only. The installer is responsible for all equipment and detailing required by local codes.

PART 6 – GAS PIPING

⚠ DANGER

FAILURE TO FOLLOW ALL PRECAUTIONS IN THIS SECTION COULD RESULT IN FIRE, EXPLOSION, OR DEATH!

A. GAS CONNECTION

The gas supply shall have a maximum inlet pressure of less than 14" w.c. (3.5 kPa), and a minimum of 3.5" w.c. (.87 kPa). The entire piping system, gas meter and regulator must be sized properly to prevent pressure drop greater than 0.5" (.12 kPa) as stated in the National Fuel Gas Code. This information is listed on the rating label.

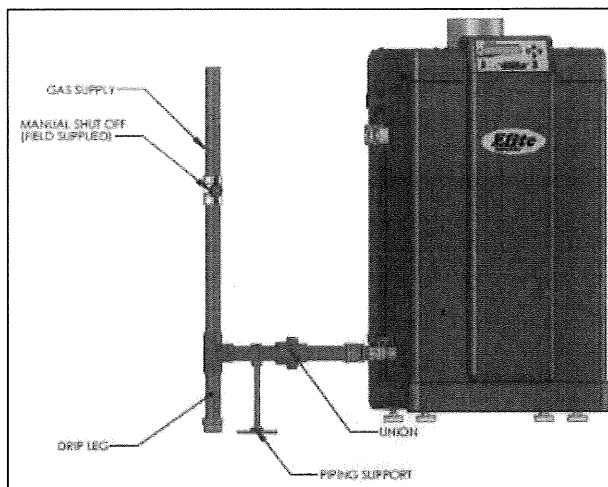

Figure 22

⚠ DANGER

It is very important that you are connected to the type of gas noted on the rating plate. "LP" for liquefied petroleum, propane gas, or "NAT" for natural or city gas. You must not do a gas conversion without an approved gas conversion kit. Prior to turning the gas on, all gas connections must be approved by the local gas supplier or utility, in addition to the governing authority.

A gas conversion kit comes with the boiler. Follow the included instructions VERY carefully. Failure to follow gas conversion instructions could result in property damage, serious injury, or death.

⚠ DANGER

The gas valve and blower will not support the weight of gas piping. Do not attempt to support the weight of piping with the boiler or its accessories. Failure to follow this warning could result in gas leakage, substantial property damage, severe personal injury, or death.

The gas connection on the boiler is 3/4" for the EL-80/110/150 and 1" for the EL-220/299/399. It is mandatory that this fitting is used for connection to a field fabricated drip leg as shown in the illustration above per the National Fuel Gas Code. You must ensure that the entire gas line to the connection at the boiler is no smaller than the unit supplied connection.

Once all inspections have been performed, the piping must be leak tested. If the leak test requirement is a higher test pressure than the maximum inlet pressure, you must isolate the boiler from the gas line. In order to do this, shut the gas off using factory and field-installed gas cocks. This will prevent high pressure. Failure to do so may damage the gas valve. In the event the gas valve is exposed to a pressure greater than 1/2 PSI, 14" w.c., or 3.5 kPa, the gas valve must be replaced. Never use an open flame (match, lighter, etc.) to check gas connections.

Gas Table

(Nominal Iron Pipe Size (inches))	Internal Diameter (inches)	Length of Pipe (Feet)								BTU'S PER HOUR x1,000
		10	20	30	40	50	60	70		
3/4	.824	278	190	152	130	115	105	96	}	
1	1.049	520	350	285	245	215	195	180		
1 1/4	1.380	1,050	730	590	500	440	400	370		
1 1/2	1.610	1,600	1,100	890	760	670	610	560		

(Nominal Iron Pipe Size (inches))	Internal Diameter (inches)	Length of Pipe (Feet)								BTU'S PER HOUR x1,000
		80	90	100	125	150	175	200		
3/4	.824	90	84	79	72	64	59	55	}	
1	1.049	170	160	150	130	120	110	100		
1 1/4	1.380	350	320	305	275	250	225	210		
1 1/2	1.610	530	490	460	410	380	350	320		

Table 13 – Gas Pipe Sizing / BTU's per Hour

B. GAS PIPING

1. Run the gas supply line in accordance with all applicable codes.
2. Locate and install manual shutoff valves in accordance with state and local requirements.
3. In Canada, the Manual Shutoff must be identified by the installing contractor.
4. It is important to support gas piping as the unit is not designed to structurally support a large amount of weight.
5. Purge all gas lines thoroughly to avoid start up issues with air in the lines.
6. Sealing compound must be approved for gas connections. Care must be taken when applying compound to prevent blockage or obstruction of gas flow which may affect the operation of the unit.

⚠ DANGER

Never use an open flame (match or lighter) to check for gas leaks. Use a soapy solution to test connection. Failure to use a soapy solution test or check gas connection for leaks can result in substantial property damage, severe personal injury, or death.

⚠ DANGER

Use two wrenches when tightening gas piping at the boiler: One to prevent the boiler gas line from turning. Failure to prevent the boiler gas connection from turning could result in damage to the gas line components, substantial property damage, severe personal injury, or death.

CAUTION

CSA / UL listed flexible gas connections can be used when installing the boiler. Flexible gas connections have different capacities and must be sized correctly for the connected boiler firing rates. Consult with the flex line supplier to assure the line size is adequate for the job. Follow local codes for proper installation and service requirements.

C. CHECK INLET GAS PRESSURE

The gas valve is equipped with an inlet gas pressure tap that can be used to measure the gas pressure to the unit. To check gas pressure, perform the steps listed below:

1. **IMPORTANT!** Before you connect to the inlet pressure, shut off the gas and electrical power to unit.
2. Loosen the pressure tap with a small screwdriver. Refer to Figure 24 for location.
3. Each unit is equipped with a needle valve that will accept a 5/16 ID hose to connect to a digital manometer or liquid gauge designed to measure incoming pressure from 0-35" w.c. See Figure 24.
4. Turn on the gas and power up the unit.
5. Put the unit into manual test mode (details on test mode are in Part 10 Section D). In service mode, monitor pressure to assure it does not drop below 1 inch from its idle reading. If gas pressure is out of range or pressure drop is excessive, contact the

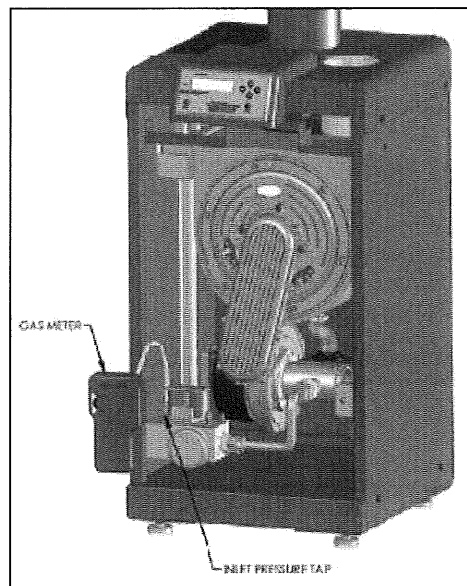

Figure 23 – LP-205-W

gas utility, gas supplier, qualified installer, or service agency to determine correct action that is needed to provide proper gas pressure to the unit. If Gas Pressure is within normal range proceed to Step 6.

6. Exit test mode, then turn power off and shut off gas supply at the manual gas valve before disconnecting the hose from the gas monitoring device. Tighten screw on the pressure tap and turn gas on. Check for leaks with soapy solution. Bubbles will appear on the pipe to indicate a leak is present.

The gas piping must be sized for the proper flow and length of pipe to avoid pressure drop. The gas meter and regulator must be properly sized for the total gas load. If you experience a pressure drop greater than 1" w.c. (.87 kPa), the meter, regulator or gas line may be undersized or in need of service. You can attach a manometer to the incoming gas drip leg after removing the cap. The gas pressure must remain between 3.5" (.87 kPa) and 14" (3.5 kPa) during stand-by (static) mode and while in operating (dynamic) mode.

If an in-line regulator is used, it must be a minimum of 10 feet from the boiler. It is very important that the gas line is properly purged by the gas supplier or utility. Failure to properly purge the lines, or improper line sizing, will result in ignition failure. This problem is especially noticeable in NEW LP installations and empty tank situations. This situation can also occur when a utility company shuts off service to an area to provide maintenance to their lines. This gas valve must not be replaced with a conventional gas valve under any circumstances.

⚠ WARNING

Ensure that the high gas pressure regulator is as least 6 – 10 feet upstream of the appliance. Failure to do so could result in substantial property damage, severe personal injury, or death.

D. BOILER GAS VALVE

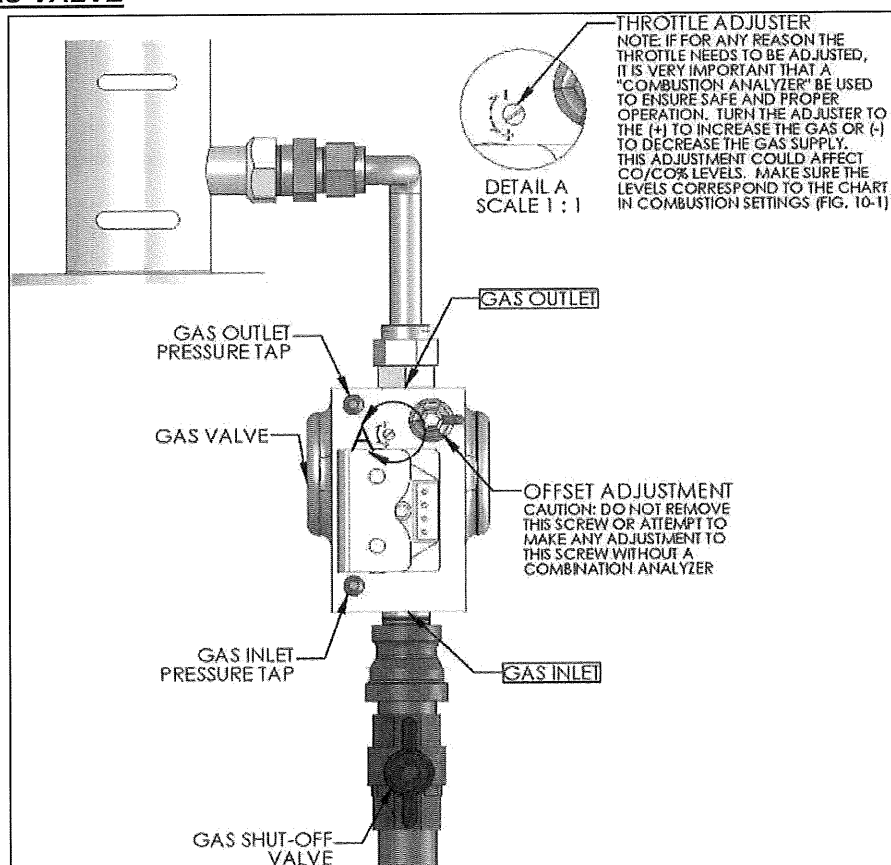

Figure 24 – LP-293-V

PART 7 – FIELD WIRING

⚠ WARNING

ELECTRICAL SHOCK HAZARD - For your safety, turn off electrical power supply at service entrance panel before making any electrical connections. Failure to do so can result in severe personal injury or death.

CAUTION

Wiring must be N.E.C. Class 1. If original wiring supplied with the boiler must be replaced, use only UL Listed TEW 105° C wire or equivalent. Boiler must be electrically grounded as required by National Electrical Code ANSI/NFPA 70 – Latest Edition.

⚠ CAUTION

To ease future service and maintenance, label all wires. Wiring errors can cause improper and dangerous operation, and result in substantial property damage, severe personal injury, or death.

A. INSTALLATION MUST COMPLY WITH:

1. National Electrical Code and any other national, state, provincial or local codes or regulations.
2. In Canada, CSA C22.1 Canadian Electrical Code Part 1, and any local codes.

B. FIELD WIRING TERMINATIONS

All connections made to the boiler in the field are done inside the electrical junction box located on the left side of the unit. Multiple knockout locations are available to route field wires into and out of the electrical junction box.

C. FIELD WIRING

The control used in the boiler is capable of directly controlling 1 pump in standard mode and 2 pumps when configured as a cascade master boiler. As a standard unit, each pump can provide a maximum of 4 amps at 120 volts. If a pump requires more than this amount of power, an external contactor or motor starter is needed. If the boiler is configured as a cascade master, the system pump output is a dry contact output capable of switching 5 amps at 120 volts, in addition to the boiler pump output sourcing 4 amps each.

The electrical junction box has separate, clearly marked terminal strips for line voltage and low voltage wiring. Special jacks are provided for trouble-free cascade system wiring using standard CAT3 or CAT5 patch cables.

D. LINE VOLTAGE WIRING FOR STANDARD BOILER

1. Connect 120V / 60Hz / 15 AMP incoming power wiring to the line voltage terminal strip in the electrical junction box at terminals 120V, Neutral, Ground (shown in Figure 26).
2. A line voltage fused disconnect or service switch may be required, externally mounted and connected according to local codes that may apply.
3. Connect the boiler pump as shown in Figure 26 to the

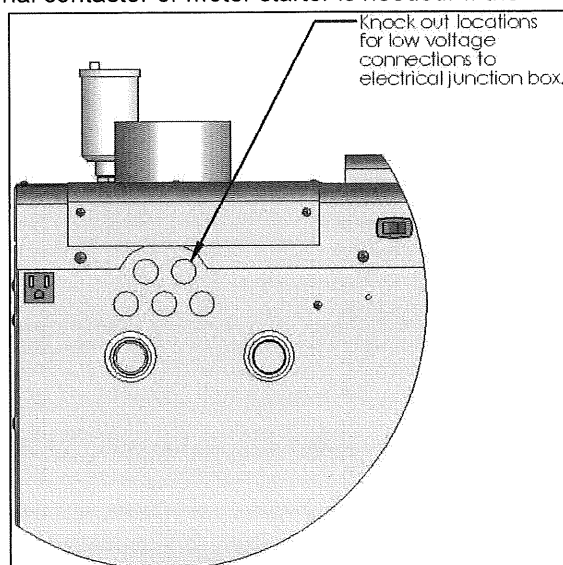

Figure 25 – Knockout Locations

terminals marked 4 – (HOT), 5 – (NEUT), and 6 – (GND). The connections shown are suitable for a maximum continuous pump draw of 3 amps at 120 volts. If the pump requires more current or voltage than the 120 volts supplied, an external motor starter or contactor will be required.

E. ALARM CONNECTIONS

The control includes a dry contact alarm output. This is an SPDT circuit, rated at 5 amps at 120 volts. This contact can be used to activate an alarm light or bell or notify a building management system if the boiler goes into a lockout condition. The circuit between the ALARM COM and NC terminals is closed during normal operation and the circuit between ALARM COM and NO is open during normal operation. The connections depicted in Figure 26 show two 120 volt lights connected to the alarm terminals. One light will be on when the boiler is in normal mode and the other light will be on when the boiler is in lockout mode.

F. LOW VOLTAGE CONNECTIONS FOR STANDARD BOILER

1. All low voltage cables should enter the electrical junction box through the provided knock out holes as shown in Figure 25.
2. Connect all low voltage field devices to the low voltage terminal strip located in the electrical junction box.

G. THERMOSTAT

1. Connect the room thermostat to the terminals marked THERMOSTAT in the electrical junction box (see Figure 2 **Error! eference source not found.**6). Alternately, any dry contact closure across these terminals will cause the boiler to run. Take caution to ensure neither of the terminals becomes connected to ground.
2. Mount the thermostat on an inside wall as central as possible to the area being heated, but away from drafts or heat producing devices such as television sets that could influence the ability of the thermostat to measure room dthw temperature.
3. If the thermostat is equipped with an anticipator and it is connected directly to the boiler, the anticipator should be set at .1 amps. If the thermostat is connected to other device(s), the anticipator should be set to match the

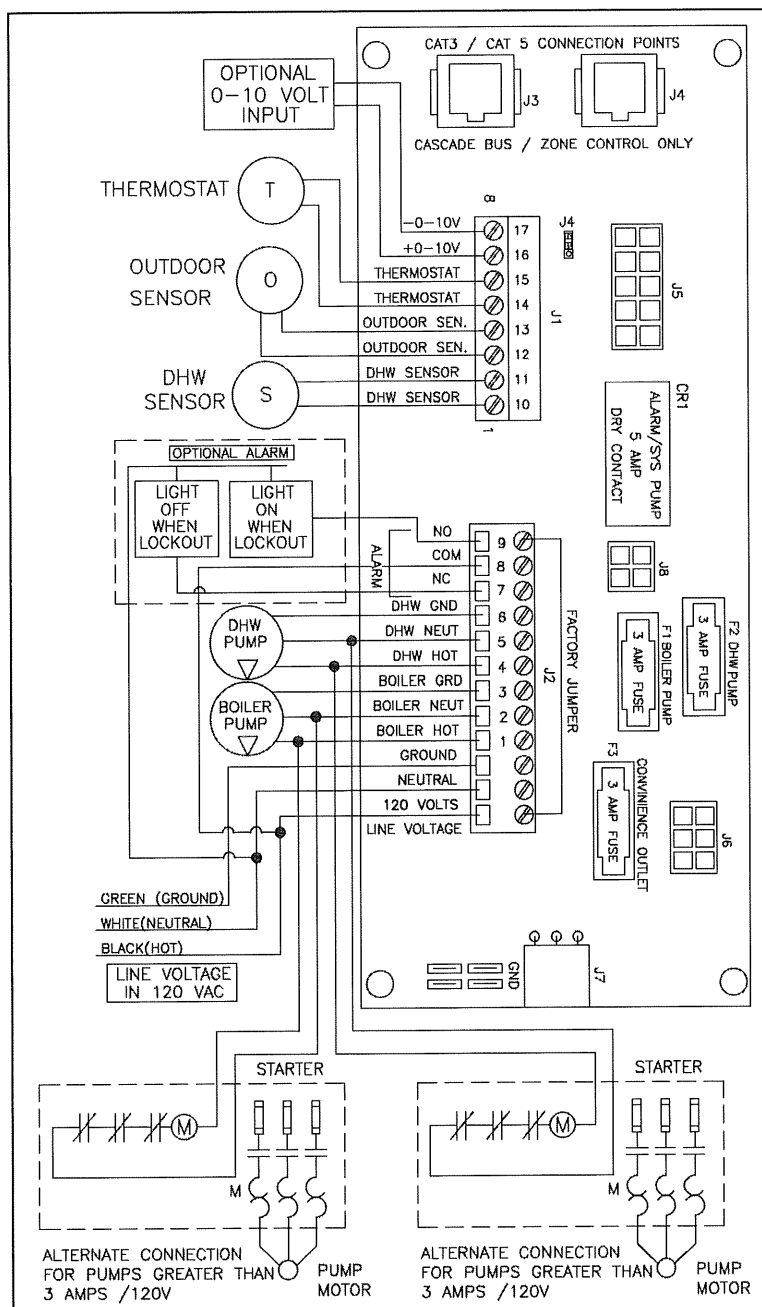

Figure 26 – LP-293-NN Elite Boiler Control

power requirements of the device(s). See the instruction manual of the connected device(s) for further information.

H. OUTDOOR SENSOR

There is no connection required if an outdoor sensor is not used in the installation.

1. Use a minimum 22 AWG wire for runs of 100 feet or less and minimum 18 AWG wire for runs of up to 150 feet.
2. Mount the outdoor sensor on an exterior surface of the building, preferably on the north side in an area that will not be affected by direct sunlight and will be exposed to varying weather conditions. NOTE: For correct mounting procedures, follow instructions provided with the sensor.

I. INDIRECT SENSOR

There is no connection required if an indirect water heater is not used in the installation.

1. The boiler will operate an indirect fired water heater with either a thermostat type aquastat installed in the indirect tank or an HTP 7250P-325 tank sensor. When a tank sensor is used, the boiler control will automatically detect its presence and a demand for heat from the indirect water heater will be generated when the tank temperature falls below the user set point by more than the user selectable offset. The demand will continue until the sensor measures that the indirect water heater temperature is above the set point.
2. Connect the indirect sensor (7250P-325) to the terminals marked DHW SENSOR (shown in Figure 26) in the electrical junction box.

WARNING

Caution should be used to ensure neither of these terminals becomes connected to ground.

J. OPTIONAL 0-10 VOLT BUILDING CONTROL SIGNAL

1. A signal from a building management system may be connected to the boiler to enable remote control. This signal should be a 0-10 volt positive-going DC signal. When this input is enabled using the installer menu, a building control system can be used to control the set point temperature of the boiler. The control interprets the 0-10 volt signal as follows; when the signal is between 0 and 1.5 volts, the boiler will be in standby mode, not firing. When the signal rises above 1.5 volts, the boiler will ignite. As the signal continues to rise towards its maximum of 10 volts, the boiler will increase in set point temperature. See Part 10 for details on the setting of function 16.
2. Connect a building management system or other auxiliary control signal to the terminals marked 16, 0-10 VOLT + and 17, 0-10 VOLT – in the electrical junction box (shown in Figure 26). Caution should be used to ensure that the 0-10 VOLT + connection does not become connected to ground.
3. Move jumper on connection board (shown in Figure 26) from A to B.
4. See Part 9, Section D, Function 17 to program the 0-10 volt signal.

NOTE: When a 0-10 volt building management system is installed, the return sensor temperature cannot be monitored through the appliance display.

K. OPTIONAL UL353 LOW WATER CUT-OFF INTERFACE KIT

If an optional UL 353 Low Water Cut-Off (LWCO) Interface Kit is used, the control box of the kit should be mounted to the left side of the boiler cabinet near the low water cut-off probe, which is located on the outlet nipple of the boiler.

Follow the complete instructions included in the kit for proper installation.

L. WIRING OF CASCADE SYSTEM COMMUNICATION BUS

1. Use standard CAT3 or CAT5 computer network patch cables to connect the communication bus between each of the boilers. These cables are readily available at any office supply, computer, electronic, department or discount home supply store in varying lengths. If you possess the skills you can also construct custom length cables.
2. It is recommended to use the shortest length cable that will reach between the boilers and create a neat installation. Do not run unprotected cables across the floor where they may become wet or damaged. Avoid running communication cables parallel and close to or against high voltage (120 volt or greater) wiring. HTP recommends that the maximum length of communication bus cables not exceed 200 feet.
3. Route the communication cables through one of the knockouts in the cabinet.
4. Connect the boilers in a daisy chain configuration as shown below. It is best to wire the boilers using the shortest wire runs rather than trying to wire them in the order that they are addressed. The communication bus jacks on the customer connection panel are interchangeable so you can use either one or both in any order to connect the cable. If you have connected the boilers to each other properly, two of the boilers will have one open connection port on them.

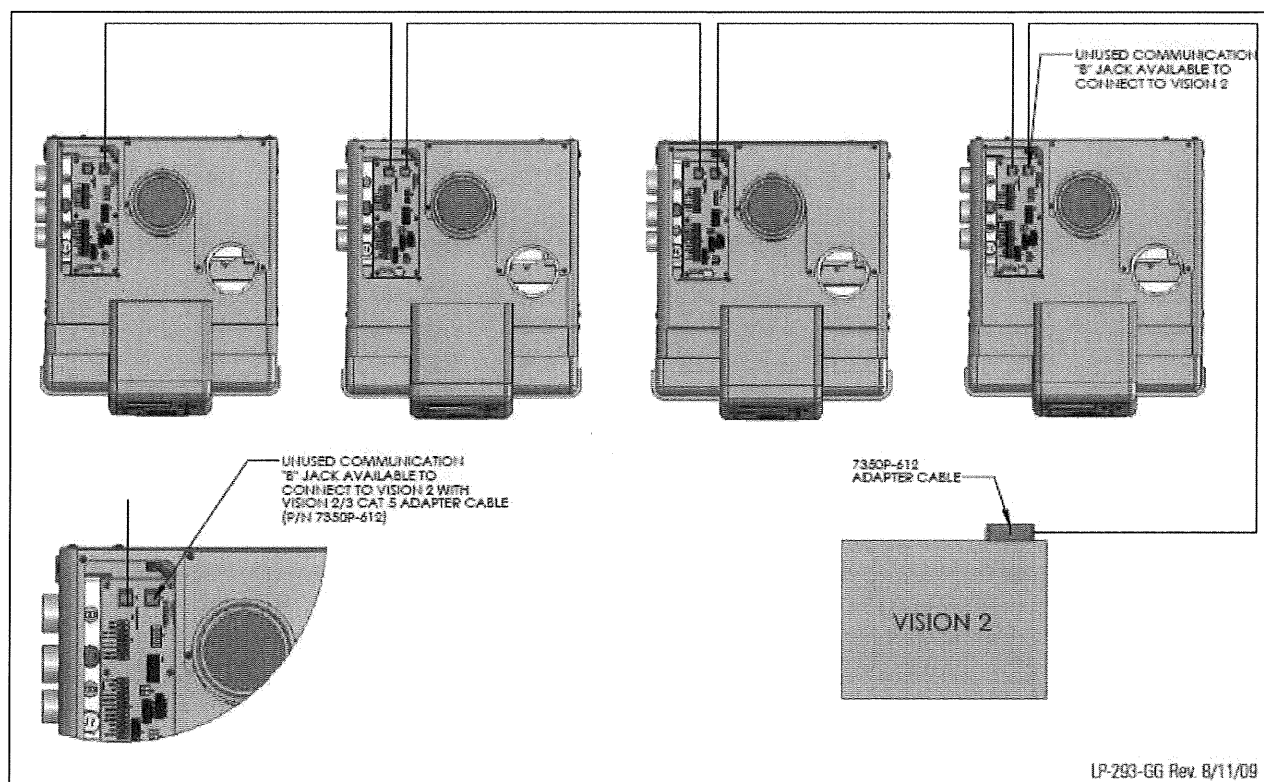

Figure 27

M. CASCADE MASTER PUMP AND SENSOR WIRING

1. Connect the system pump hot wire to the terminal marked 8.

2. Connect the system pump neutral to the 2 terminal and the pump ground wire to the 3 terminal.
3. Connect a jumper wire from the 120 VOLT terminal to the 9 terminal.
4. Connect the boiler pump to the terminals marked 4 (HOT), 5 (NEUT) and 6 (GND).
5. Connect the system pipe sensor to the terminals marked 10 and 11.

N. CASCADE FOLLOWER PUMP AND SENSOR WIRING

1. Connect the boiler pump to the terminals labeled 4 (HOT), 5 (NEUT), and 6 (GND).
2. An alarm bell or light can be connected to the alarm contacts of the follower boiler. The normally closed alarm contact may be used to turn a device off if the boiler goes into lockout mode. The alarm contacts are rated 5 amps at 120 VAC.

To connect an alarm device, connect the power for the device to the ALARM COM terminal. Connect the alarm device hot wire to the ALARM NO terminal. Connect the neutral or return of the alarm device to the neutral or return of the power for the alarm device.

To connect a device that should be powered off during a boiler lockout condition, follow the same instructions as above except use the ALARM NC terminal rather than the ALARM NO terminal.

Note that in a cascade system the alarm output of the boiler addressed as #1 will also be active if the master boiler has a lockout condition. The alarm output of boilers addressed as 2-7 will only activate an alarm if a lockout condition occurs on that specific boiler.

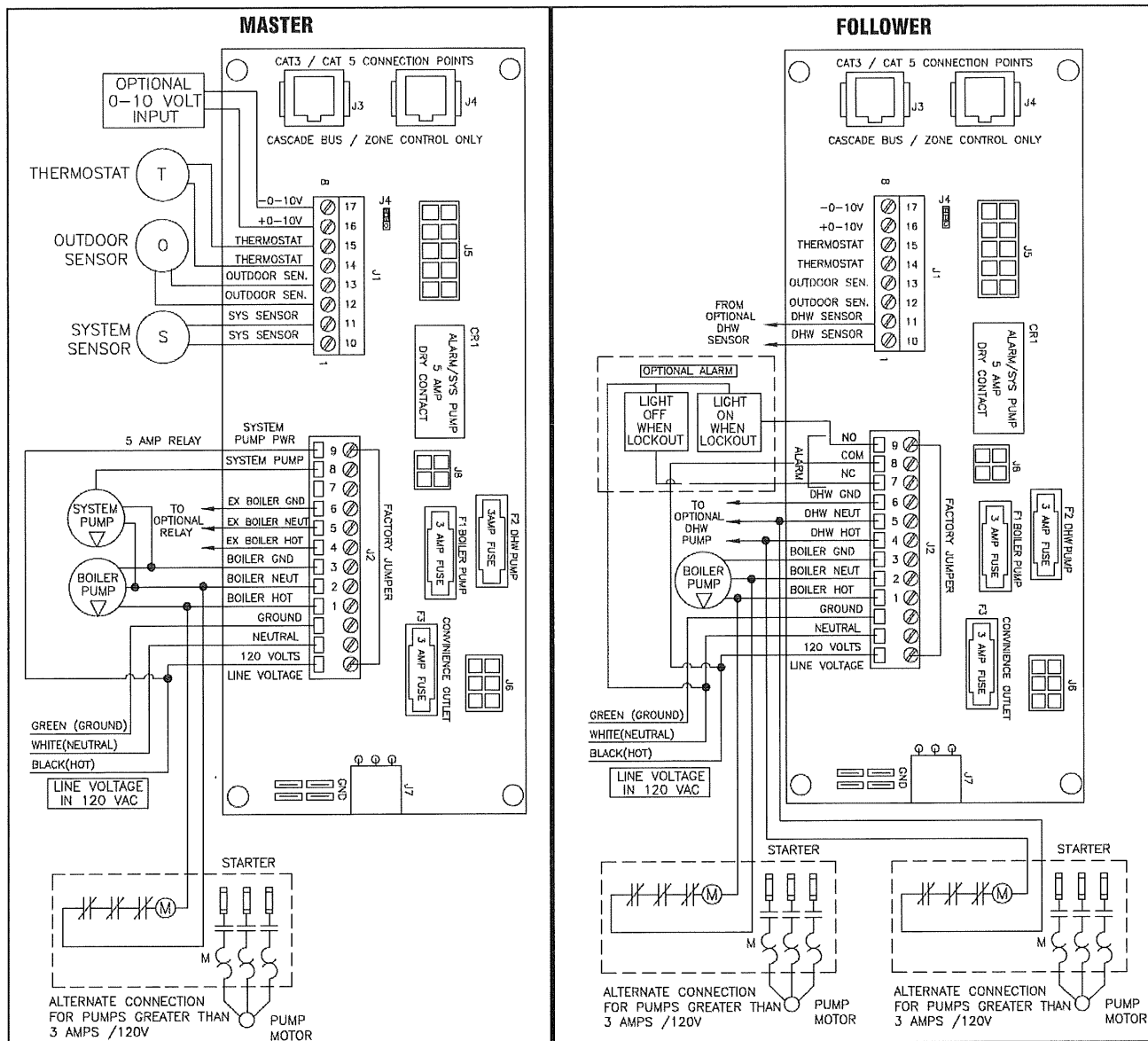
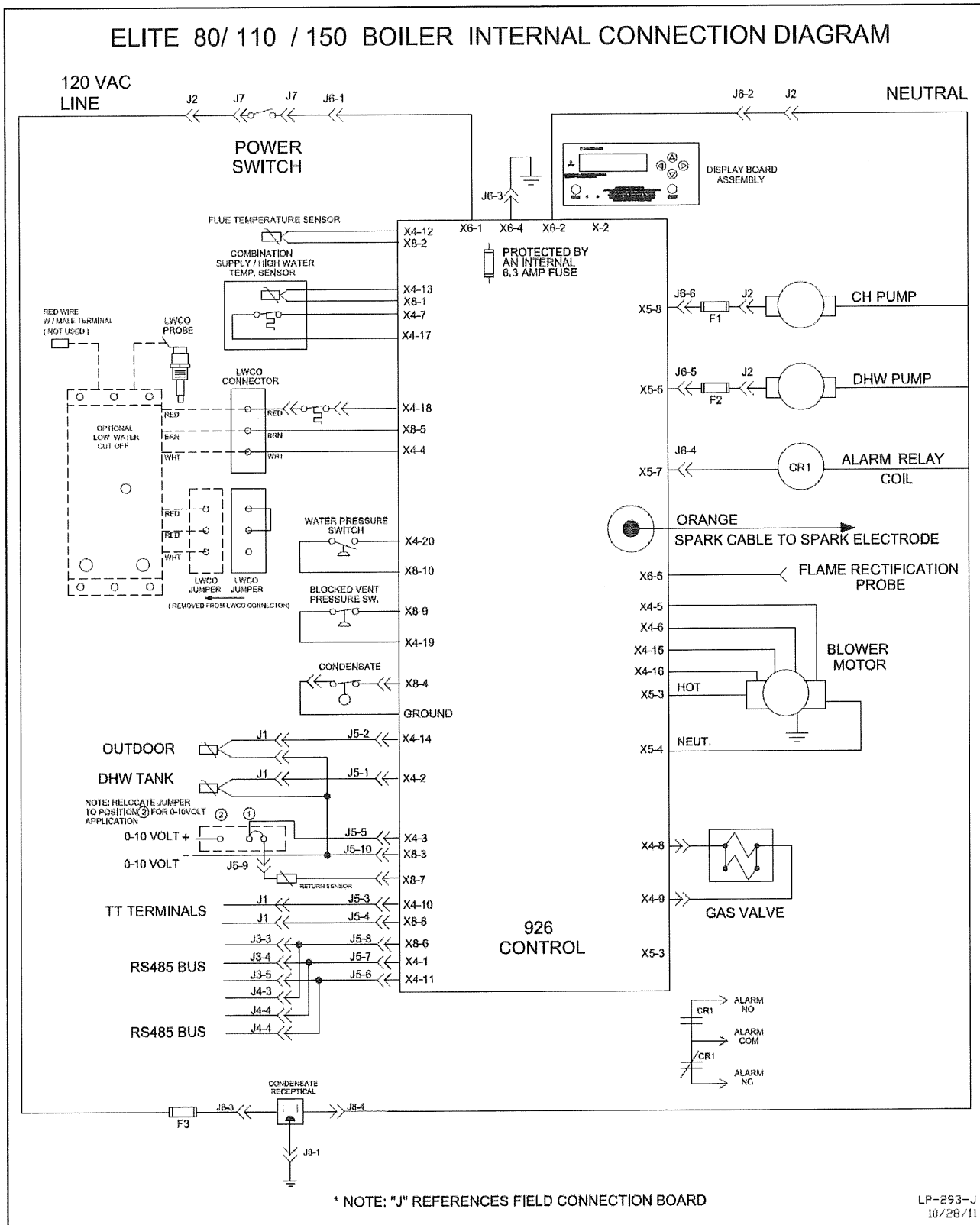

Figure 28 – Cascade Master and Follower

ELITE 80/ 110 / 150 BOILER INTERNAL CONNECTION DIAGRAM



LP-293-J
10/28/11

Figure 29

ELITE 220 / 299 / 399 BOILER INTERNAL CONNECTION DIAGRAM

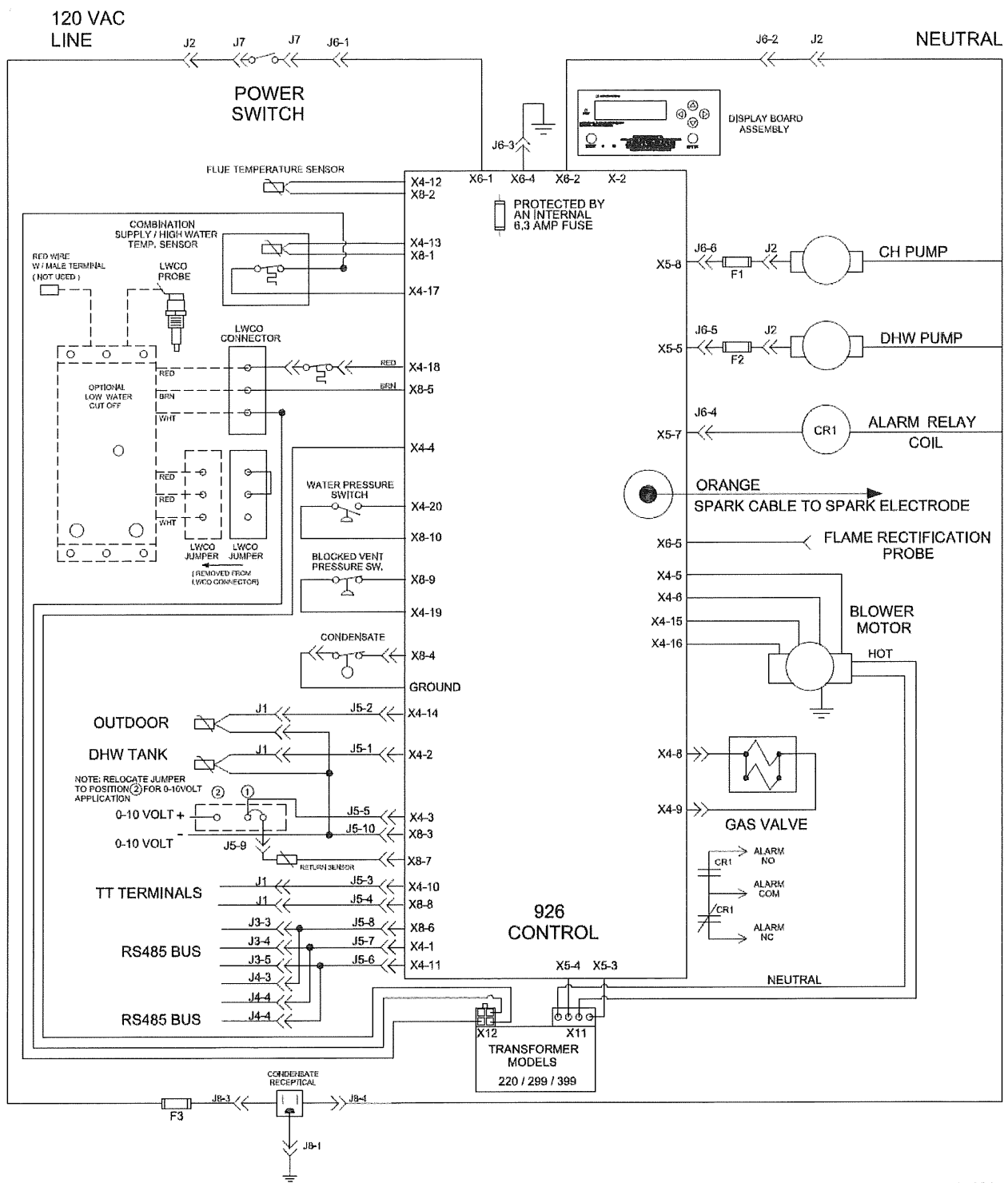

* NOTE: "J" REFERENCES FIELD CONNECTION BOARD

LP-293-J1
10/23/11

Figure 30

PART 8 – START-UP PREPARATION

A. CHECK / CONTROL WATER CHEMISTRY

To assure good extended service life, it is recommended that you test your water quality prior to installation. Listed below are some guidelines.

⚠ WARNING

Do not use petroleum-based cleaning or sealing compounds in the boiler system. Damage to elastomer seals and gaskets in the system could occur, resulting in substantial property damage.

Sodium less than 20 mGL

Water pH between 6.0 and 8.0

1. Maintain boiler water pH between 6.0 and 8.0. Check with litmus paper or have chemically analyzed by water treatment company.
2. If pH differs from above, consult local water treatment company for treatment needed.

Hardness less than 7 grains

Consult local water treatment companies for unusually hard water areas (above 7 grains hardness).

Chlorine concentration less than 200 ppm

1. Filling with chlorinated fresh water should be acceptable since drinking water chlorine levels are typically less than 5 ppm.
2. Do not use the boiler to directly heat swimming pool or spa water.
3. Do not fill boiler or operate with water containing chlorine in excess of 200 ppm.

Clean system to remove sediment*

1. You must thoroughly flush the system (without boiler connected) to remove sediment. The high-efficiency heat exchanger can be damaged by buildup or corrosion due to sediment.
2. For zoned systems, flush each zone separately through a purge valve. (If purge valves and isolation valves are not already installed, install them to properly clean the system.)
3. Flush system until water runs clean and you are sure piping is free of sediment.

***NOTE:** It is recommended you clean heat exchanger at least once a year to prevent lime scale buildup. Follow the maintenance procedure to clean the heat exchanger in the Maintenance Section (Part 12 of this manual).

Test/replace freeze protection fluid

1. For systems using freeze protection fluids, follow fluid manufacturer's instructions to verify inhibitor level and that other fluid characteristics are satisfactory.
2. Freeze protection fluid must be replaced periodically due to degradation of inhibitors over time. Follow all fluid manufacturer instructions.

NOTE: BOILER FAILURE DUE TO IMPROPER WATER CHEMISTRY IS NOT COVERED BY WARRANTY.

B. CHECK FOR GAS LEAKS**⚠ WARNING**

Before starting the boiler, and during initial operation, smell near the floor and around the boiler for gas odorant or any unusual odor. Remove boiler front door and smell interior of boiler enclosure. Do not proceed with startup if there is any indication of a gas leak. Repair any leaks at once.

⚠ WARNING

PROPANE BOILERS ONLY – Your propane supplier mixes an odorant with the propane to make its presence detectable. In some instances, the odorant can fade, and the gas may no longer have an odor. Before startup (and periodically thereafter), have the propane supplier verify the correct odorant level in the gas.

C. FREEZE PROTECTION (WHEN USED)**⚠ WARNING**

NEVER use automotive or standard glycol antifreeze. Do not use ethylene glycol made for hydronic systems. Use only freeze-protection fluids certified by fluid manufacturer as suitable for use with stainless steel boilers, verified in the fluid manufacturer's literature. Thoroughly clean and flush any system that has used glycol before installing the new boiler. Provide the boiler owner with a material safety data sheet (MSDS) on the fluid used.

1. Determine the freeze protection fluid quantity using total system water content following the fluid manufacturer's instructions. Remember to include expansion tank water content.
2. Local codes may require back flow preventer or actual disconnect from city water supply.
3. When using freeze protection fluid with automatic fill, install a water meter to monitor water makeup. Freeze protection fluid may leak before the water begins to leak, causing concentration to drop, reducing the freeze protection level.

D. FILL AND TEST WATER SYSTEM

1. Fill the system only after ensuring water chemistry meets the requirements listed in this manual.
2. Close the manual and automatic air vents and boiler drain valve.
3. Fill to the correct system pressure. Correct pressure will vary with each application.
 - a. Typical cold water fill pressure for a residential system is 12 psi.
 - b. Pressure will rise when boiler is turned on and system water temperature increases. Operating pressure must never exceed the relief valve pressure setting.
4. At initial fill and during boiler startup and testing, check system thoroughly for leaks. Repair all leaks before proceeding further.

⚠ WARNING

Eliminate all system leaks. Continual fresh make-up water will reduce boiler life. Minerals can build up in the heat exchanger, reducing heat transfer, overheating the heat exchanger and causing heat exchanger failure.

5. The system may have residual substances that could affect water chemistry. After the system has been filled and leak tested, verify that water pH and chlorine concentrations are acceptable by sample testing.

▲ CAUTION

It is important to purge the system of air to avoid damage to the boiler.

E. PURGE AIR FROM WATER SYSTEM

1. Purge air from the system:
 - a. Connect a hose to the purge valve and route hose to an area where water can drain and be seen.
 - b. Close the boiler or system isolation valve between the purge valve and fill connection to the system.
 - c. Close zone isolation valves.
 - d. Open quick-fill valve on cold water make-up line.
 - e. Open purge valve.
 - f. Open the isolation valves one zone at a time. Allow water to run through the zone, pushing out the air. Run water until no noticeable air flow is present. Close the zone isolation valves and proceed with the next zone. Follow this procedure until all zones are purged.
 - g. Close the quick-fill water valve and purge valve and remove the hose. Open all isolation valves. Watch the system pressure rise to correct cold-fill pressure. It is recommended that you put the pumps into manual operation to assist in purging the circuits.
 - h. Disconnect the wires that are connected to the THERMOSTAT terminals of the customer connection board. Apply power to the boiler. The display will show the temperature of the water in the boiler. Press the ▼ and **ENTER** keys simultaneously and hold for 1 second. The display will read:

```
SERVICE PUMP CH
PUMP ON           11:47A
```

The central heating pump will come on. If you then press the ▲ key, the central heating pump will shut off. The display will read:

```
SERVICE PUMP DH
PUMP ON           11:47A
```

The DHW pump will come on. If the boiler is set up as the cascade master and you press the ▲ key again, the DHW pump will shut off. The display will read:

```
SERVICE PUMP SH
PUMP ON           11:47A
```

The system pump will come on. Use the ▲ and ▼ keys to toggle between running each pump in the system as required to help bleed out all entrapped air. Some good indicators that air is removed include the absence of gurgling noises in the pipes and pump operation becoming very quiet. Pressing ▲ and ▼ together at any time will return the boiler to normal operation.

- i. After the system has operated for awhile, eliminate any residual air by using the manual air vents located throughout the system.
- j. If purge valves are not installed in the system, open manual air vents in the system one at a time, beginning with the lowest floor. Close vent when water squirts out. Repeat with remaining vents.
- k. Refill to correct pressure.

F. CHECK THERMOSTAT CIRCUIT(S)

1. Disconnect the two external wires connected to the boiler thermostat terminals (low voltage terminal strip).
2. Connect a voltmeter across these two incoming wires with power supplied to the thermostat circuits. Close each thermostat, zone valve and relay in the external circuit one at a time and check the voltmeter reading across the incoming wires.
3. There should NEVER be a voltage reading.

4. If a voltage reading does occur under any condition, check and correct the external wiring. (This is a common problem when using 3-wire zone valves.)

5. Once the external thermostat circuit wiring is checked and corrected if necessary, reconnect the external thermostat circuit wires to the boiler low voltage terminal strip. Allow the boiler to cycle.

G. CONDENSATE REMOVAL

1. The boiler is a high efficiency condensing boiler. Therefore, the unit has a condensate drain. Condensate fluid is nothing more than water vapor, derived from combustion products, similar to that produced by an automobile when it is initially started.

Condensation is slightly acidic (typically with a pH of 3 to 5) and must be piped with the correct materials. Never pipe the condensate using steel, copper, brass or other materials that will be subject to corrosion. Plastic PVC or CPVC pipe are the only approved materials.

A condensate neutralizer, if required by local authorities, can be made up of lime crystals, limestone or phosphate chips that will neutralize the condensate. This may be done by the installer or you may purchase a condensate neutralizer from HTP (7450-212).

2. The boiler is equipped with a ¾ female socket weld fitting connection that must be piped to a local drain. It is very important that the condensate line is sloped downward away from the boiler to a suitable inside drain. If the condensate outlet on the appliance is lower than the drain, you must use a condensate removal pump, available from HTP (554200). This pump is equipped with two leads that can be connected to an alarm or another type of warning device to alert the user of a condensate overflow, which, if not corrected, could cause property damage.

3. If a long horizontal run is used, it may be necessary to create a vent in the horizontal run to prevent a vacuum lock in the condensate line.

4. Do not expose the condensate to freezing temperatures.

5. It is very important you support the condensation line to assure proper drainage.

H. FINAL CHECKS BEFORE STARTING BOILER

1. Read Start-Up Procedure, Part 9 in this manual, for proper steps to start boiler. (See Start-Up Report to record steps for future reference.)

2. Verify the boiler and system are full of water and all system components are correctly set for operation.

3. Fill the condensate trap with water.

4. Verify electrical connections are correct and securely attached.

5. Inspect intake and exhaust piping for signs of deterioration from corrosion, physical damage, or sagging. Verify intake and exhaust piping are intact and correctly installed per Venting Section (Part 5) and local codes.

I. CASCADE SYSTEM

1. If a single boiler is installed, skip this section.

2. Programming the Master Boiler:

- a. Make sure there is no demand for heat being supplied to the boiler.
- b. Apply power to the boiler.

- c. Enter the system setting program navigation following instructions in Part 10 of this manual.
- d. Verify that the cascade address function 15 is set to 0. This sets the Master Boiler's address as 0.
- NOTE: The Master Boiler MUST be addressed as 0.
- e. Change cascade mode function 23 to 926 Boiler. This makes it a Master Boiler.
- f. Exit the installer menu.

NOTE: In order for the system to operate properly, the temperature set point of the master must match the follower boiler set point.

NOTE: READ THE NOTES BELOW BEFORE PROGRAMMING FOLLOWER BOILERS:

- The boiler addressed as 1 will share its alarm output with the master boiler.
- If one of the follower boilers has an indirect fired water heater connected to it, the address of this boiler must be 2 or greater.
- It is recommended but not necessary to address boilers in the order that they are wired.
- No two boilers can have the same address.
- It is not required to use all consecutive address numbers. Example: In a 2 boiler system with an indirect connected to the follower, the follower address would be 2 (address 1 is not used).

3. Programming Follower Boilers:

- a. Make sure there is no demand for heat being supplied to the master boiler.
- b. Apply power to the follower boiler you are working on.
- c. Enter the system settings following instructions in Part 10 of this manual.
- d. Set the Cascade Address parameter 15 to 1 for the first follower, 2 for the second follower, etc., depending on which boiler you are programming.
- e. Change "CASCADE MODE" parameter to "926 BOILER". This makes the boiler a follower and enables all data to be transferred between boilers as needed for the system to function to full capability.
- f. Exit the system menu.

NOTE: For the system to operate properly, the temperature set point of the follower must match that of the master boiler.

J. LOCKOUT CONDITION

If any boilers, including the master boiler in the cascade system, are in a lockout condition, the master control will recognize the lockout condition and skip over the boiler in the firing sequence. Each boiler in the cascade system is responsible for its own safety functions. So, if any individual boiler control senses an unsafe condition, it will extinguish the burner and, if necessary, go to a lockout condition. In this way, every boiler in the system has its individual safety controls intact and operational, even if the firing of the boiler is under control of the master boiler.

PART 9 – START-UP PROCEDURE

FOR YOUR OWN SAFETY READ BEFORE OPERATING

1. This appliance does not have pilot. It is equipped with an ignition device which automatically lights the burner. Do not try to light the burner by hand.
2. BEFORE OPERATING: smell all around the appliance area for gas. Be sure to smell next to the floor because some gas is heavier than air and will settle on the floor.

WHAT TO DO IF YOU SMELL GAS

- Do not try to light any appliance.
- Do not touch any electric switch; do not use any phone in your building.
- Immediately call your gas supplier from a neighbor's phone. Follow the gas suppliers' instructions.

- If you cannot reach your gas supplier, call the fire department.
- Turn off gas shutoff valve (located outside of the boiler) so that the handle is crosswise to the gas pipe. If the handle will not turn by hand, don't try to force or repair it, call a qualified service technician. Force or attempted repair may result in a fire or explosion.

4. Do not use this appliance if any part has been under water. Immediately call a qualified service technician to inspect the appliance and to replace any part of the control system and any gas control that has been damaged.

5. The boiler shall be installed so the gas ignition system components are protected from water (dripping, spraying, rain, etc.) during appliance operation and service (circulator replacement, condensate trap, control replacement, etc.)

WARNING

If you discover any evidence of a gas leak, shut down the boiler at once. Find the leak source with a bubble test and repair immediately. Do not start the boiler again until the leak is repaired. Failure to comply could result in substantial property damage, severe personal injury, or death.

A. CONTROL OVERVIEW

The control is one of the primary safety devices of the boiler. It monitors the safety sensors of the boiler to assure safe and efficient operation.

The control has many features associated with system design. This section addresses programming features, including Boiler Settings / System Settings / Maintenance Settings and System Diagnostics, to help in customizing your control. It is important to fully understand control capabilities before customization, as its factory defaults may already fit your system design and not require any adjustment at all.

B. NAVIGATION OF THE DISPLAY

The display includes a two-line backlit LCD readout to provide informative messages about the operation of the boiler. Many operating parameters can be viewed and adjusted by using the six buttons on the display. The function of each button is described below.

RESET – The RESET button has two functions.

- Resets any lockout error code
- Returns the user to the default display screen.

ENTER – The ENTER key is used to enter the parameter programming mode. To enter this mode, hold down the ENTER key for more than 4 seconds. The readout will change to:

ENTER MENU CODE 000

One of the zeroes will be blinking. Use the ▲▼ arrow keys to change the blinking digit to the correct value. Use the ◀▶ arrow keys to select the next digit to change and again use the ▼▲ keys to change the value. Repeat until the correct code is entered. Press the **ENTER** key to accept the code entered. If the code is correct, the readout will change to the appropriate screen. If the programming code is not accepted, the readout will continue to display as shown above.

The **ENTER** key is also used to enable a function for editing. After the user navigates to the desired function, the user would hold down the **ENTER** key for one second. When the **ENTER** key is released, the function value will begin to blink. The function can now be changed using the ▼▲ **ARROW** keys. After the new value is displayed, the user then presses the **ENTER** key for 1 second to lock the new value of the function in. The value will then stop blinking.

LEFT AND RIGHT ARROW KEYS – ◀▶ are used to navigate between the default display, status display, analog and cascade displays if they are enabled. The ◀▶ keys are also used in programming modes to change

between the programmable functions. It is recommended you use the Menu Maps in the back of this manual and the detailed menu instructions printed in this section to help in menu navigation.

UP AND DOWN ARROW KEYS – ▼▲ are used to navigate between the various functions displayed in the menu. After the function is enabled for editing by pushing the **ENTER** key, the ▼▲ keys are used to adjust the function upward or downward to the desired value.

C. OPERATING INSTRUCTIONS

Before operating the unit, it is important to remove the cover and verify that the gas line and water lines are connected to boiler and fully purged. If you smell gas, **STOP**; Follow the safety instructions listed in the first part of this section. If you do not smell gas, follow the next steps.

1. Turn down the thermostats before applying power to the boiler. If 0–10 volt or other inputs are used, make sure that they are set so there is no call for heat while programming.
2. Turn on the power to the boiler or boilers if a cascade system used.
3. Next, check the boiler settings. Adjustment and factory defaults are outlined within this section. If a cascade system is used, it is important that all the boilers have the same boiler settings.
4. Next, check the system settings. Adjustments and factory defaults are outlined within this section. If a cascade system is used, it is important that the Master Boiler is programmed with the correct system settings.
5. Create a demand on the boiler or boilers if a cascade system is used. The user can monitor system functions when the boilers are operational.
6. If the boilers fail to start, refer to the troubleshooting section in the back of this manual.

D. PROGRAMMING BOILER SETTINGS

Boiler Setting Program Access

NOTE: Programming the boiler control is not possible when the boiler is firing. Make sure any input which can create a demand on the boiler, such as the tank thermostat, is turned off, so the boiler will remain idle to allow programming.

SCREEN	DESCRIPTION
ENTER MENU CODE 000	To access the boiler setting program, press and hold the ENTER Key for 4 seconds, until the display shows the screen at left.
ENTER MENU CODE 600	Using the arrow keys, log in the Boiler Menu Access Code "600" . To confirm the code, press ENTER to access Boiler Setting Program navigation menu.

Table 14 – Programming Screens

Boiler Setting Program Navigation

Once the code is confirmed, the user can now start to set the **Boiler Settings**. Use the arrow keys on the display to navigate through the **Boiler Setting Program**. A blinking setting indicates it can be changed. To change a setting, press the **ENTER** Key. Boiler settings can be increased by pressing the **UP ARROW ▲** and decreased by pressing the **DOWN ARROW ▼** on the display. When done, press **ENTER**. Setting will stop blinking and you can move on to next setting. Press **RESET** to exit programming and store settings. Listed below are the boiler settings that can be programmed into the control.

SCREEN	DESCRIPTION
CENTRAL HEAT 180 °F	Function: Adjusts the boiler set point. Default: 180°F (Range: 50°F to 190°F).

CENTRAL DIFF SET 30 °F	Function: Adjusts the boiler differential set point. Default: 30°F (Range: 5°F to 30°F).
DHW SET POINT 119 °F	Function: Adjusts the indirect tank set point. Default: 119°F (Range: 70°F to 185°F).
DHW DIFF SET POINT 7 °F	Function: Adjusts the indirect tank differential set point. Default: 7°F (Range: 1°F to 30°F).
TEMP DISPLAY C OR F °F	Function: Adjusts the temperature measurement in F = Fahrenheit to C = Celsius (Default is Fahrenheit).

Table 15 – Boiler Setting Screen Descriptions

Clock Settings

(NOTE: The clock will reset if the boiler is powered off for more than a week.)

SCREEN	DESCRIPTION
CLOCK MODE (12/24) 08/28/2009 Fr 9:42A	Function: Changes the clock from 12 hour mode (8:45 PM) to 24 hour mode (20:45). To change to 24 hour mode, press the ENTER key. The letter (A or P) after the time will blink. Press the up or down arrow key once and the letter will disappear. Press the ENTER key to save the new setting.
CLOCK HOUR 08/28/2009 Fr 10:01A	Function: Allows the user to adjust the hour setting.
CLOCK MINUTE 08/28/2009 Fr 10:01A	Function: Adjusts the minute setting.
CLOCK DAY OF WEEK 08/28/2009 Fr 10:01A	Function: Adjusts the day of week.
CLOCK DATE MODE 08/28/2009 Fr 10:01A	Function: Allows the user to switch to European date format (2009/08/28) from US format (08/28/2009).
CLOCK YEAR 08/28/2009 Fr 10:01A	Function: Adjusts the year setting.
CLOCK MONTH 08/28/2009 Fr 10:01A	Function: Adjusts the month setting.
CLOCK DATE 08/28/2009 Fr 10:01A	The clock is set.

Table 16 – Clock Setting Screens

NOTE: The clock does not automatically adjust for Daylight Savings Time, and requires manual adjustment.

E. PROGRAMMING THE SYSTEM SETTING**System Setting Program Access**

NOTE: Programming the boiler control is not possible when the boiler is firing. Make sure any input which can create a demand on the boiler, such as the tank thermostat, is turned off, so the boiler will remain idle to allow programming.

SCREEN	DESCRIPTION
ENTER MENU CODE 000	To access the boiler setting program, press and hold the ENTER Key for 4 seconds, until the display shows the screen at left.
ENTER MENU CODE 925	Using the arrow keys on the display, log in your System Menu Access Code "925" . To confirm code, press ENTER to access system setting program navigation menu.

Table 17 – System Setting Access

F. SYSTEM SETTING PROGRAM NAVIGATION

Once the **System Menu Access Code** is confirmed, the user can begin to set the system setting menu. Use the ◀▶ arrow keys on the display to navigate through the system setting program. To change a setting, press **ENTER**. System settings can be **increased** by pressing the **UP ARROW** and **decreased** by pressing the **DOWN ARROW** on the display. When done, press **ENTER**. Setting will stop blinking and you can move on to next setting. Press **RESET** to exit programming and store settings. Listed below are the boiler settings that can be programmed into the control.

SCREEN	DESCRIPTION
Function 1	Factory Program Mode
MODE INDIRECT 1	This screen indicates that the control is configured correctly. Do not change this setting.
Function 3	DHW Tank Max Temp
DHW TANK MAX TEMP 180 °F 3	This is the maximum temperature that can be selected for the DHW indirect tank set point in the boiler menu. Default: 180°F (Range: 95°F to 180°F).
Function 6	DHW Post Pump Time
DHW POST PUMP TIME 0 MINUTES 6	The indirect pump has the ability to post purge energy from the boiler to run the pump after the set point has been achieved. Please note that running the pump for a time greater than 5 minutes may cause tank energy to be released back to the boiler heat exchanger. Default: 0 Minutes (Range: 0 – 10 minutes).
Function 7	Warm Weather Shutoff
WARM WEATHER OFF 68 °F 7	When used with an outdoor sensor, warm weather shut down will disable the boiler if the programmed outdoor temperature is exceeded. Default: 68°F (Range: 41°F to 122°F).
Function 8	Min Outdoor Temp
MIN OUTDOOR TEMP 5 °F 8	Sets the minimum outdoor design temperature for the system. Default: 5°F (Range: -49°F to 32°F).
Function 9	Max Supply Temp
MAX SUPPLY TEMP 190 °F 9	Sets the maximum design supply temperature based on the minimum outdoor design temperature. Default: 190°F (Range: 77°F to 190°F).
Function 10	Max Outdoor Temp
MAX OUTDOOR TEMP 68 °F 10	Sets the maximum outdoor design temperature for the system design. Default: 68°F (Range 32°F to 190°F).
Function 11	Min Supply Temp
MIN SUPPLY TEMP 95 °F 11	Sets the design supply water temperature based on the maximum outdoor design temperature. Default: 95°F (Range: 32°F to 190°F).
Function 12	Min Boiler Temp
MIN BOILER TEMP 68 °F 12	Sets the design minimum heat curve temperature for central heat. Default: 68°F (Range: 32°F to 190°F).
Function 13	CH Post Pump Time
CH POST PUMP TIME 0 MINUTES 13	Allows the user to set the boiler pump post purge time once the thermostat is satisfied. Default: 0 minutes (Range: 0 – 10 minutes).
Function 14	DHW Priority
DHW PRIORITY 30 MINUTES 14	Allows the user to set the maximum run time for the indirect fired water heater and the minimum run time for central heating. Default: 30 minutes (Range: 0 – 60 minutes).
Function 15	Cascade Address
CASCADE ADDRESS 0 15	Bus addressing boilers (maximum boilers allowed 8 in a cascade system). Master Boiler address is 0 and Following Boilers are addressed 1 thru 7. Default: 0 (Range: 0 – 8). NOTE: DO NOT USE ADDRESS 8.
Function 16	Optional Inputs
OPTIONAL INPUT RETURN SEN 16	Allows the user to select from optional inputs to control or monitor the system. Default: RETURN (Range: Off / Booster Board / 0-10 Volt / DHW Sensor / Return Sen).
Function 17	0-10 Volt Function
0-10 VOLT FUNCTION TEMPERATURE 17	Allows the user to control boiler modulation through temperature control. Default: Temperature (Range: Temperature or Fan Speed).
Function 18	Step Modulation Mode
STEP MODULATE MODE ON 18	Allows the user to turn ON the step modulation, which regulates burner output in six steps at one minute intervals. Step modulation will start at the last modulation rate of the boiler and work up one minute at a time. Default: OFF (Selection: OFF or ON).
Function 19	Boiler DHW Temp
BOILER SUPPLY DHW 180°F 19	Allows the user to program the boiler supply water temperature to the indirect heat exchanger during a demand cycle. Default: 180°F (Range: 119°F to 190°F).

Function 20	Water Safety Input
WATER SAFETY INPUT WATER PRESSURE 20	The user can select various water safety inputs used in the boiler system. Default: Flow Switch (Range: None / Low Water Cut off / Flow Switch / Water Pressure).
Function 21	Error Outdoor Sensor
ERROR OUTD SENSOR OFF 21	Allows the user to set the control to display an error message if an outdoor sensor is open or shorted. NOTE: This error does not stop the boiler from running. Factory Default: OFF (Range: ON / OFF / PHOEN ON).
Function 22	Adjust Boiler Output %
ADJ BOILER OUTPUT 100% 22	Allows the user to adjust the boiler output down from 100% to 50%. Factory Default: 100%. (Range: 100% – 50%)
Function 23	Cascade Mode
CASCADE MODE VISION 3 23	Allows the user to select cascade mode. Factory Default: Vision 3 (Range: 926 Boilers / Vision 3).
Function 24	Cascade Rotation
CASCADE ROTATION 48 HOURS 24	Sets the amount of hours before the first boiler in the cascade firing rotation will be changed. NOTE: If this parameter is set to 0, the firing order of the boilers will not rotate. Default: 48 hours (Range: 0 – 240 hours).
Function 25	Cascade DHW Mode
NOT USED NOT USED 25	Not used on this product.
Function 26	System Freeze Protect
SYS FREEZE PROT PROTECT OFF 26	NOTE: This parameter is only present if the boiler is a cascade master. Allows the user to set the freeze protection when a system pump is used. Factory Default: OFF. Selection of temperature activates freeze protection. (Range: OFF, -40°F – 104°F).
Function 27	Error System Sensor
ERROR SYSTEM SENS ON 27	Allows the user to set the control to display an error message if the system sensor is open or shorted. NOTE: This error does not stop the boiler (or boilers) from running. Factory Default: ON (Range: ON / OFF).
Function 28	Freeze Protection
FREEZE PROTECTION ON 28	Allows the user to set freeze protection on the boiler. Factory Default: ON (Range: ON / OFF).
Function 29	DHW Modulation Mode
DHW MODULATE MODE NORMAL MOD 29	This parameter controls how the boiler modulates for a DHW demand. In NORMAL MOD mode, the boiler will modulate down from high fire when there is a DHW demand. In LOW MOD mode, the boiler will modulate up from low fire when there is a DHW demand. This mode is useful to minimize short cycling when a large boiler and small indirect tank are used together. Factory Default: NORMAL MOD (Range: NORMAL MOD / LOW MOD).
Function 30	Extra Boiler Mode
EXTRA BOILER MODE OFF 30	Allows for a non HTP boiler to be controlled when the cascade output has risen above the percent of the cascade firing rate set in this parameter. Factory Default: Off (Range: 50% - 100%).
Function 31	System Sensor Mode
SYSTEM SENSOR MODE OFF 31	Suppresses the 'NO FOLLOWER' message on the display if the boiler is used as a cascade master boiler with no follower boilers connected. Factory Default: OFF (Range: ON / OFF).
Function 32	Service Schedule
SERVICE SCHEDULE OFF 32	Allows the user to select a service date or time based on the boiler run hours to program the boiler maintenance schedule. Factory Default: OFF (Range: Date or Run Hours). NOTE: Without setting this function, Functions 33/34/35/36 will not display.

Table 18 – System Setting Menu Screens

NOTE: For the following functions, you must have your maintenance function turned on.

To change, press **ENTER**. The left most digit will begin to blink. Use the up ▲ or down ▼ arrows to change the digit. Use the ◀ ▶ arrow keys to switch between digits. When you've made your selection, press **ENTER** again.

SCREEN	DESCRIPTION
Function 33	Year
SERVICE SCHEDULE YEAR 00/00/2000 33	Allows the user to set the year of the next service reminder.
	Hours
SERVICE SCHEDULE 10000's 000000h 33	Allows the user to set the left two digits of the amount of run hours before next service reminder.
Function 34	Month
SERVICE SCHEDULE MONTH 00/00/2000 34	If the date function was selected, this function allows the user to program the month. If you selected the run hour function, you will need to program 10,000 hours, if required.

	Hours
SERVICE SCHEDULE 10000's 000000 34	Allows the user to set the two middle digits of the amount of run hours for the next service reminder.
Function 35	Day
SERVICE SCHEDULE DAY 00/00/2000 35	Allows the user to set the day of next service reminder.
	Hours
SERVICE SCHEDULE 10000's 000000 35	Allows the user to set the 2 right digits of the amount of run hours for the next service reminder.
Function 36	Telephone
TELEPHONE # 000 000 0000 36	Allows the user to input a telephone number that will be displayed when maintenance is required.

Table 19 – Maintenance Reminder Function Screens

G. RESETTING THE MAINTENANCE SCHEDULE

When the system control flashes MAINTENANCE REQUIRED, it is advisable that you call for service. After the service is performed, reset the schedule for the next required service by using the following steps.

Press **ENTER** on the display for 3 seconds. The Menu code will appear as 000. This does not change. Press **ENTER** again. SERVICE SCHEDULE RESET will be displayed. Using the right arrow key ► scroll to the selection of year or hours. Select enter to reset the mode you are in. Use the up ▲ or down ▼ arrow key for each adjustment then select **ENTER** when reset is complete.

PART 10 – START-UP PROCEDURES FOR THE INSTALLER

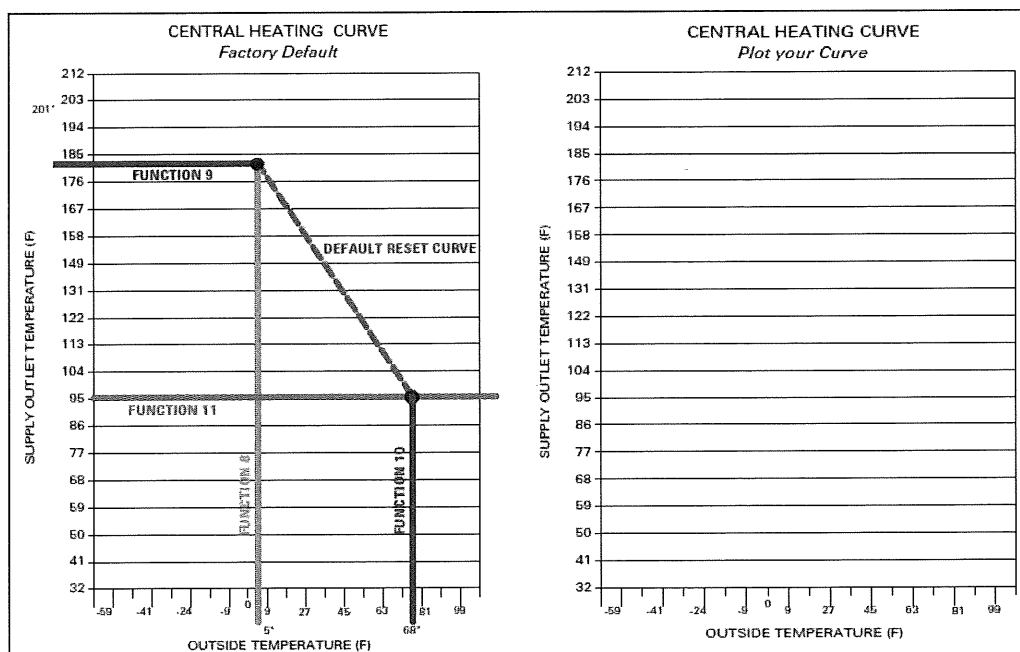

Table 20 – NOTE: It is important to note that the user can adjust the heat curve down by lowering the central heating temperature.

A. BOILER CONTROL STATUS MENU

The boiler control also has the ability to review the status of the system. To access the status screens, simply press the right arrow ►. Once the first value is displayed, press the up arrow ▲ or down arrow ▼ to access additional information. At any point you may press the RESET button to exit the status screen. Listed below are the status screens.

SCREEN	DESCRIPTION
SUPPLY SEN 180°F RETURN SEN 150°F	This screen is displayed after pressing the ► key as described above. This shows the actual temperature that the supply and return sensors are measuring. NOTE: If the boiler is configured to use a 0 – 10 volt input, the return sensor is disabled and the second line of the display will be blank.
Press the ▼ key once.	
CH SET 180°F SUPPLY 122°F	The screen displays the current central heating temperature set point on the top line. NOTE: This temperature set point may vary from what was set in the boiler settings if an outdoor sensor is used. The actual temperature measured by the supply sensor is displayed on the bottom line.
Press the ▼ key once.	
CH DEMAND OFF BOILER	This screen displays the central heat demand set for the cascade system.
Press the ▼ key once.	
0-10 SIGNAL ON *	Shows if 0 – 10 volt is enabled.
Press the ▼ key once.	
CAS SET 190 °F SYSTEM 112 °F	NOTE: This screen will appear only when set in Master Boiler mode. This screen displays the cascade set point (maximum 190°F) on the top line. The system sensor value reading is on the second line. The control will cascade the boilers up to this set point depending on demand.
Press the ▼ key once.	
DHW SET 119 °F DHW 117 °F	This screen displays the domestic hot water temperature set point on the top line. The actual temperature measured by the tank or return line sensor (HTP 7250P-325) is displayed on the bottom line. If a mechanical aquastat is used in place of the recommended sensor, the second line will display 'OFF' in place of the temperature if the aquastat measures close to its set temperature, or 'ON' in place of the temperature if the aquastat temperature is too low.
Press the ▼ key once.	
OUTDOOR 11 °F FLUE 95 °F	The current outdoor temperature is displayed on the top line. If there is no outdoor sensor connected to the boiler, this line will display 'OFF' in place of the temperature. If the outdoor sensor is shorted, this line will display 'ON' in place of the temperature. The second line displays the current flue temperature of the boiler.
Press the ▼ key once.	
FLAME 0.0uA FAN SPEED 3497 RPM	This screen displays the boiler flame current on the top line. The second line displays the fan speed in the boiler.
Press the ▼ key once.	
0-10 V 0.0 V BOILER	The top line displays the voltage on the optional input. This voltage is only relevant if an external 0-10 volt signal is being used to control the boiler.
Press the ▼ key once.	
BUS COMM NO CONN	This display shows the status of the communication bus between multiple boilers. If the boiler is in a single boiler configuration, the display will show 'NO CONN'. If the boiler is used in a multiple boiler configuration, is the Master Boiler, and other boilers are connected to the communication bus and powered, this screen will show the address of each boiler connected to the bus.
Press the ▼ key once.	
POWER ON 0H CH ON 0H	The top line of this display indicates the amount of hours the boiler has had power applied to it over its life. The second line indicates how many hours the burner has been on for central heat demand over its life.
Press the ▼ key once.	
DHW ON GOOD IGNIT 1X	The top line of this display indicates the amount of hours the burner has been on for domestic hot water demand in the life of the boiler. The second line indicates how many times the burner has successfully ignited in the life of the boiler.
Press the ▼ key once.	
SYS CH ON 0h SYS DWH ON 0h	This screen displays how many hours the boiler has run to meet central heat and DWH demand.

Table 21 – Boiler Control Status Menu Screens

The following 10 screens display the last ten boiler lockout faults. The faults are displayed from most recent to oldest by pressing the ▼ key.

SCREEN	DESCRIPTION
Press the ▼ key once.	
FAULT HISTORY 1 07/27/2009 Mo 5:19A	This screen displays the last lockout fault the boiler controller had. The top line will alternate between the words 'FAULT HISTORY' and the actual fault encountered. The bottom line displays the date and time the fault occurred.

Press the ▼ key once.	
FAULT HISTORY 2 08/28/2009 Fr 5:19A	This screen displays the second oldest lockout fault that occurred in the boiler controller. The top line will alternate between the words 'FAULT HISTORY' and the actual fault encountered. The bottom line will display the date and time that the fault occurred.
Press the ▼ key once.	
FAULT HISTORY 3 08/28/2009 Fr 5:19A	This screen displays the third oldest lockout fault that occurred in the boiler controller. The top line will alternate between the words 'FAULT HISTORY' and the actual fault encountered if one has occurred. The bottom line displays the date and time a fault occurred.
Press the ▼ key once.	
FAULT HISTORY 4 08/28/2009 Fr 5:19A	This screen displays the fourth oldest lockout fault that occurred in the boiler controller. The top line will alternate between the words 'FAULT HISTORY' and the fault encountered. The bottom line displays the date and time the fault occurred.
Press the ▼ key once.	
FAULT HISTORY 5 08/28/2009 Fr 5:19A	This screen displays the fifth oldest lockout fault that occurred in the boiler controller. The top line will alternate between the words 'FAULT HISTORY' and the fault encountered. The bottom line displays the date and time the fault occurred.
Press the ▼ key once.	
FAULT HISTORY 6 08/28/2009 Fr 5:19A	This screen displays the sixth oldest lockout fault that occurred in the boiler controller. The top line will alternate between the words 'FAULT HISTORY' and the fault encountered. The bottom line displays the date and time the fault occurred.
Press the ▼ key once.	
FAULT HISTORY 7 08/28/2009 Fr 5:19A	This screen displays the seventh oldest lockout fault that occurred in the boiler controller. The top line will alternate between the words 'FAULT HISTORY' and the fault encountered. The bottom line displays the date and time the fault occurred.
Press the ▼ key once.	
FAULT HISTORY 8 08/28/2009 Fr 5:19A	This screen displays the eighth oldest lockout fault that occurred in the boiler controller. The top line will alternate between the words 'FAULT HISTORY' and the fault encountered. The bottom line displays the date and time the fault occurred.
Press the ▼ key once.	
FAULT HISTORY 9 08/28/2009 Fr 5:19A	This screen displays the ninth oldest lockout fault that occurred in the boiler controller. The top line will alternate between the words 'FAULT HISTORY' and the fault encountered. The bottom line displays the date and time the fault occurred.
Press the ▼ key once.	
FAULT HISTORY 10 08/28/2009 Fr 5:19A	This screen displays the tenth oldest lockout fault that occurred in the boiler controller. The top line will alternate between the words 'FAULT HISTORY' and the fault encountered. The bottom line displays the date and time the fault occurred.

Table 22 – Fault History Screens

B. BOILER TEST MODE

This function is intended to simplify the gas adjustment. Listed in **Table 24** are the recommended combustion settings for the gas type selected to run the boilers. Automatic modulation does not take place when the controller is in test mode. However, the boilers will modulate down if the program set point is reached while running in test mode. It is recommended you have the largest load possible to create a heat demand so the test mode operation will not be interrupted. To enter test mode, press the ▲ and **ENTER** keys simultaneously. To exit, press ▲ and ▼ simultaneously.

NOTE: The boiler will automatically exit test mode after 20 minutes of operation.

C. CASCADE MENU

This menu is accessed by pressing the ◀ key from the default menu or the ▶ key from the status menu.

SCREEN	DESCRIPTION
CASCADE MASTER READY SYS PUMP OFF	This screen tells the user that the boiler is configured as a Cascade Master Boiler and that the cascade system is ready to accept a demand for heat. The second line indicates the status of the system pump output of the cascade system. This screen will alternate with the default screen every 5 seconds or it can be accessed by pressing the ◀ key from the default screen.
CASCADE NO FOLLOWER SYS PUMP OFF	This screen is displayed when the boiler is configured as a Master Boiler and there are no connected follower boilers, or the follower boilers are not powered. The second line indicates status of the cascade system pump output. This screen will alternate with the default screen every 5 seconds or it can be accessed by pressing the ◀ key from the default screen.

CASCADE NO SENSOR SYS PUMP OFF	This screen is displayed when the boiler is configured as a Master Boiler and there is no system temperature sensor connected or the system sensor is defective. The cascade system will still function in this situation with reduced efficiency. All boilers will run simultaneously rather than in a staged fashion. The second line indicates the status of the system pump output of the cascade system. This screen will alternate with the default screen every 5 seconds or it can be accessed by pressing the ◀ key from the default screen.
CASCADE TT 0123 567 SYS PUMP ON 12:47P	Shows information about cascade status. The TT in the center of the top line shows that the cascade demand is coming from the TT contact being closed. You may also see DHW if the demand is from a DHW sensor, or 0-10 if the demand is from a 0-10 volt input. The following numbers show which boiler addresses are currently communicating to the master. If a boiler address is not used or communicating, the number will not show on the display. In the example above, boiler address #4 is not communicating. When a boiler in the system is firing, its address number will alternate with a '.' to signify it is firing. The bottom line shows the status of system pump output contacts.
Press the ▼ key once.	
CASCADE PWR 100% PRESENT 01234567	This screen shows the overall cascade power output. The range of this value is the number of boilers communicating with the Master x 100. For example, if 8 boilers are connected and communicating, the maximum cascade power is 800%. The second line shows which boiler addresses are communicating with the Master.
Press the ▼ key once.	
CASCADE SYST 118°F CASCADE SET 190°F	This screen shows the current system temperature sensor reading on the top line and the cascade system temperature setting on the bottom.
Press the ▼ key once.	
BOILER 0 100% BOILER 1 56%	This screen shows the current cascade power demand output on a per connected boiler basis for boilers addressed as 0 and 1. In the screen above, boiler 0 is being commanded to fire at 100% and boiler 1 at 56%. If this were a 2 boiler system, the 'CASCADE PWR' screen above would read 156%.
Press the ▼ key once.	
BOILER 2 0% BOILER 3 0%	This screen shows the current cascade power demand output on a per connected boiler basis for boilers addressed as 2 and 3.
Press the ▼ key once.	
BOILER 4 0% BOILER 5 0%	This screen shows the current cascade power demand output on a per connected boiler basis for boilers addressed as 4 and 5.
Press the ▼ key once.	
BOILER 6 0% BOILER 7 0%	This screen shows the current cascade power demand output on a per connected boiler basis for boilers addressed as 6 and 7.

Table 23 – Cascade Menu Screens

COMBUSTION SETTINGS ON ALL MODELS				
	NATURAL GAS		PROPANE LP	
	Low	High	Low	High
CARBON MONOXIDE (CO%)	0 – 20 ppm	70 – 135 ppm	0 – 20 ppm	80 – 150 ppm
CARBON DIOXIDE (CO ₂ %)	8 ½% - 9 ½%	8 ½% - 9 ½%	9 ½% - 10 ½%	9 ½% - 10 ½%

Table 24

ELITE FAN SPEEDS			
MODEL	IGNITION	MIN	MAX
80	3000	1700	4600
110	3800	1700	4950
150	3800	1700	5200
220	3000	1450	4900
299	3000	1450	5000
399	3000	1600	6650

Table 25

D. TEST MODE ACCESS

To activate the test mode, be sure the appropriate pumps are running, then press the ▲ and ENTER keys together for 1 second. The boiler will go through the ignition sequence. Then the user can adjust the fan speed by pressing ▲ to increase or ▼ to decrease fan speed.

To leave service mode, press the ▲ and ▼ keys simultaneously.

SERVICE RUN	3400 RPM
PUMP ON	4:49P

PART 11 – TROUBLESHOOTING

A. BOILER ERROR CODE

If any of the sensors detect an abnormal condition, or an internal component fails during the operation of the boiler, the display may show an error message and error code. This message and code may be the result of a temporary condition, in which case the display will revert to its normal readout when the condition is corrected, or it may be a condition that the controller has evaluated as not safe to restart the boiler. In this case, the boiler control will be locked out, the red FAULT light will be lit, and the message "LOCKOUT" will be displayed on the readout on the lower line.

The Boiler will not start until a qualified technician has repaired the boiler and pressed the RESET button for more than 1 second. If there is an error message displayed on the readout, and the message "LOCKOUT" is not displayed and the FAULT light is not lit, then the message is the result of a temporary condition and will disappear when the problem corrects itself.

IMPORTANT NOTE: If you see error messages on your display readout, call a technician immediately, since the message may indicate a more serious problem will occur soon.

B. BOILER ERROR

When an error condition occurs, the controller will display a description and code on the display readout. These error messages and their recommended corrective actions are described in Section D.

C. BOILER FAULT

1. When a fault condition occurs, the controller will illuminate the red "FAULT" indication light and display a fault message in the screen. The alarm output will also activate. Most fault conditions cause the CH pump to run in an attempt to cool the boiler.
2. Note the fault message displayed and refer to Section D in this part for an explanation of the message along with several suggestions for corrective actions.
3. Press the reset key to clear the fault and resume operation. Be sure to observe the operation of the unit for a period of time to assure correct operation and no reoccurrence of fault message.

WARNING

When servicing or replacing any components of this boiler, be certain that:

- The gas is off.
- All electrical power is disconnected.

DANGER

When servicing or replacing components that are in direct contact with boiler water, be certain that:

- There is no pressure in the boiler. (Pull the release on the relief valve. Do not depend on the pressure gauge reading.)
- The boiler water is not hot.
- The electrical power is disconnected.

⚠ WARNING

Do not use this appliance if any part has been under water. Improper or dangerous operation may result. Contact a qualified service technician to inspect the boiler and to repair or replace any part of the boiler that has been under water prior to placing the boiler back in operation.

⚠ CAUTION

This appliance has wire function labels on all internal wiring. Observe the position of each wire before removing it. Wiring errors may cause improper and dangerous operation. Verify proper operation after servicing.

⚠ CAUTION

If overheating occurs, or the gas supply fails to shut off, do not turn off electrical power to the circulating pump. This may aggravate the problem and increase the likelihood of boiler damage. Instead, shut off the gas supply to the boiler at the gas service valve.

D. USER INTERFACE DISPLAY

Cascade Control FAULT Codes

SCREEN	DESCRIPTION	POSSIBLE REMEDY
Fault Code EO3 System Sensor Failure		
SYS SUPPLY SENSOR PUMP OFF EO3	<p>This screen shows that there is a problem with the system sensor circuit. The circuit could be open or shorted. Possible reasons for this error are:</p> <p>There is no system sensor connected to the Master Boiler.</p> <p>The system sensor is faulty.</p> <p>There is a short circuit in the system sensor wiring; possibly from a staple placed through the wire, or damage to the wire causing both conductors to touch.</p> <p>The system sensor wiring is open due to defect or damage.</p>	<p>Disconnect the system sensor from the wiring and measure the resistance of it. Compare the measured resistance to the table in this manual to see if it corresponds to the temperature of the sensor. If the resistance does not agree with the sensor, replace the sensor. If the sensor is OK, disconnect the sensor wiring from both the boiler and the sensor and check continuity using an ohmmeter. Repair or replace as necessary.</p> <p>If this error is present, all boilers in the cascaded group will run and ignite simultaneously when there is a heat demand. Each boiler will modulate to maintain set point temperature on its own supply sensor. This code will reset automatically when repair is complete. This code will not display if system setting function ERROR SYSTEM SENS is set to OFF.</p>
Fault Code TT Temperature Blocking TT Demand		
TEMPER BLOCKING PUMP ON TT	<p>This screen indicates a temporary hold on the burner. There is a demand on the boiler, the pump is powered on, but the temperature of the water at the supply sensor is too high for the boiler to ignite. This occurs because the water temperature measured by the supply sensor is higher than the boiler temperature – ignition diff setting. This error will clear itself when the water temperature measured by the supply sensor is less than the boiler temperature – ignition diff setting.</p>	
Fault Code DHW Temperature Blocking DHW Demand		
TEMPER BLOCKING PUMP ON DHW	<p>This display indicates a temporary hold on the burner. There is a demand on the boiler from the DHW circuit for heat, the pump is powered on, but the boiler supply sensor indicates that the water temperature is too high to ignite. This is a temporary hold on the burner only and all other functions will remain functioning properly. This error will clear itself when either the boiler supply temperature drops below the BOILER SUPPLY minus boiler supply differential (5°F) or DHW SETPOINT is satisfied and no longer calls for heat.</p>	
Fault Code PRO		
LOW WATER PRESS PUMP OFF PRO	<p>This display indicates that there is low water pressure in the boiler. This code will reset automatically after the water pressure is high enough for the boiler to run safely. The second line indicates the status of the pump. Note that while the water pressure is low, the pump will be off.</p>	<ol style="list-style-type: none"> 1. Assure that the system pressure is above 10 psig. 2. Check for leaks in the system piping.

Fault Code FLU		
HIGH FLUE PRESS FLU PUMP ON	This display indicates that there is excessive flue pressure. This code resets automatically after the high pressure condition is resolved. The second line indicates the status of the pump.	<ol style="list-style-type: none"> 1. Assure that the flue is not blocked. 2. Check the switch wiring by applying a jumper in place of the switch. If the code clears with the jumper in place, REPLACE the flue switch and connect the wires to the new switch BEFORE running boiler.
WARNING: Do not use jumper to remedy an FLU error. Faulty switch MUST be replaced. Failure to do so could result in serious injury or death.		
Fault Code LOU		
24 VOLT LOW LOU PUMP ON	This display indicates that the 24 volt power supply on the control is damaged or overloaded. This code resets automatically if it is the result of an overload and that overload condition is removed. The second line indicates the status of the pump. Note that while 24 volt power is low, the pump output will be on.	<ol style="list-style-type: none"> 1. Check line voltage. It must be between 100 and 128 volts. 2. If available, connect PC, and using HTP service software check the 24v supply display in the lower left corner of the screen. The number displayed here must be greater than 128 and should be no greater than 250. Use this as a troubleshooting guide as you follow the steps below. 3. Remove the 10 pin Molex connector from customer connection board. If the message clears, then the problem is with the external sensor wiring. Examine the external sensor wiring for shorts to the ground, repairing as necessary. If the message is still present and the boiler is so equipped, disconnect the UL 353 low water cut-off to see if the message clears. Replace the faulty part. Check the low voltage wire harness in boiler for shorts to ground. 4. If a message only occurs when the burner tries to light, check the gas valve for excessive current draw. 5. If a message is present with the low voltage harness disconnected from the 926 control board, replace the 926 control board.
Fault Code F00		
WATER HIGH TEMP F00 PUMP ON	This display indicates if the water in the boiler has overheated. This code indicates a serious safety issue and the boiler will not restart until it cools sufficiently and a technician repairs the cause of overheating and pushes the RESET button on the display. This is a serious situation and is indicated by the red light on the display illuminating and the word LOCKOUT flashing on the display. During this lockout fault, the pump will be on as indicated on the second line in an effort to cool the boiler down.	<ol style="list-style-type: none"> 1. Check circulator pump operation 2. If the circulator pump is running, be sure that there is water in the system and that the water is moving through the system as intended. Be sure that all correct ball valves and or zone valves are open or closed as intended. 3. Observe the temperature/pressure gauge. If the water is not too hot and this message is displayed, check the wiring to the water ECO sensor and repair if necessary. If the wiring is ok and this code is still present and the water is not excessively hot, replace the ECO sensor.
Fault Code F01		
FLUE TEMP/WAT LV F01 PUMP ON	This display indicates that the flue temperature limit switch of the boiler has tripped or that the water level in the boiler is low (this will only occur if the optional UL353 LWCO is installed). This code indicates a serious safety issue. The boiler will not restart until the flue cools down sufficiently or the water level is restored. A technician must repair the cause of the problem and push the RESET button first on the low water cut-off control box, then on the display. This situation is indicated by the red light on the display and the word LOCKOUT flashing on the display. During this lockout fault, the pump will be on as indicated on the second line of the display.	<ol style="list-style-type: none"> 1. If the boiler has a UL353 LWCO, check if the red LED on the LWCO control box is illuminated. If so, correct the low water condition and press the reset button on the LWCO control box to reset the LWCO. The LED should change to green. Press the reset button on the front panel of the boiler to reset the boiler control. 2. Check the flue for obstructions or any sign of damage, especially signs of excessive heat. Repair as necessary. Push the red reset button on the flue temperature switch located on the flue inside the rear access door of the boiler. NOTE: The switch temperature must be less than 90°F to reset. Press the reset button on the display. Run the boiler and check the flue temperature by using both an external thermometer in the flue pipe and the flue temperature display in the status screens. If the flue temperature is within specs and the switch trips, replace the switch. If the flue temperature is excessive, check and adjust combustion controls on the boiler. If the problem persists, inspect the target wall in the combustion chamber and replace it if cracked or damaged.

Fault Code F02		
SUPPLY SENSOR F02 PUMP ON	Indicates that the supply temperature sensor of the boiler has failed. This is a serious safety issue and the boiler will not restart until the sensor is replaced by a technician and he pushes the RESET button on the display. This situation is indicated by the red light on the display and the flashing word LOCKOUT. During this lockout fault, the pump will be on as indicated on the second line of the display.	<ol style="list-style-type: none"> 1. Check the electrical connection to the thermistor on the outlet manifold. Verify 5 VDC by checking in Molex connector. If there is no 5 VDC, check the harness. If harness is OK, replace control. NOTE: The boiler will reset automatically. Verify thermistor values by referencing chart in this manual. 2. Replace thermistor if necessary.
Fault Code F03		
RETURN SENSOR F03 PUMP ON	This display indicates that the return temperature sensor of the boiler has failed. This code indicates a serious safety issue and the boiler will not restart until the sensor is replaced by a technician and he pushes the RESET button on the display. This situation is indicated by the red light on the display and the word LOCKOUT flashing on the display. During this lockout fault, the pump will be on as indicated on the second line of the display.	<ol style="list-style-type: none"> 1. Check circulator pump operation. 2. Assure that there is adequate flow through the boiler by accessing the status menu and assuring that there is less than a 50°F rise from the return thermistor to the supply thermistor. 3. Troubleshoot thermistor by following steps in F02.
Fault Code F04		
FLUE SENSOR F04 PUMP ON	This display indicates that the flue temperature sensor of the boiler has failed. This is a serious safety issue. The boiler will not restart until the sensor is replaced by a technician and he pushes the RESET button on the display. This situation is indicated by the red light and the flashing word LOCKOUT on the display. During this lockout fault, the pump will be on as indicated on the second line of the display.	Inspect the flue sensor for physical damage or corrosion and replace it if necessary. Check the electrical connection to the flue sensor and repair as necessary. Measure the resistance of the sensor and refer to the chart in Table 17 of this manual. The temperature on the chart should be close to the same as the temperature in the flue. If not, replace the flue sensor.
Fault Code F05		
SUPPLY TEMP HIGH F05 PUMP ON	This display indicates that the supply temperature of the boiler is excessive. If accompanied by the red FAULT light and LOCKOUT flashing on the display, this code indicates that the temperature on the supply sensor has exceeded 230°F and a serious safety issue exists. The boiler will not restart until the cause of excessive temperature is repaired by a technician and the RESET button is pushed on the display. If the FAULT light is not illuminated and this message is displayed, then the supply temperature of the boiler is at or above 210°F. The message will clear automatically when the temperature drops below 194°F. During the time that this message or lockout fault is displayed, the pump will be on as indicated on the second line.	<ol style="list-style-type: none"> 1. Check circulator pump operation. 2. Assure that there is adequate flow through the boiler by accessing the status menu and assuring that there is less than a 50°F rise from the return thermistor to the supply thermistor. 3. Check the direction of flow off the boiler circulator. (See Piping Details in this manual.) 4. Troubleshoot the thermistor by following steps in F02.
Fault Code F06		
RETURN TEMP HIGH F06 PUMP ON	This display indicates that the return temperature of the boiler is excessive. If accompanied by the red FAULT light and LOCKOUT flashing on the display, the return sensor temperature has exceeded 230°F and a serious safety issue exists. The boiler will not restart until the cause of excessive temperature is repaired by a technician and the boiler is RESET. If the red FAULT light is not illuminated, then the return temperature of the boiler is at or above 210°F. The message will clear automatically when the temperature drops below 194° F. During the time that this message or lockout fault is displayed, the pump will be on as indicated on the second line.	<ol style="list-style-type: none"> 1. Check circulator pump operation. 2. Assure that there is adequate flow through the boiler by accessing the status menu and assuring that there is less than a 50°F rise from the return thermistor to the supply thermistor. 3. Check the direction of flow on boiler circulator. (See Piping Details in this manual.) 4. Troubleshoot thermistor by following steps in F02.

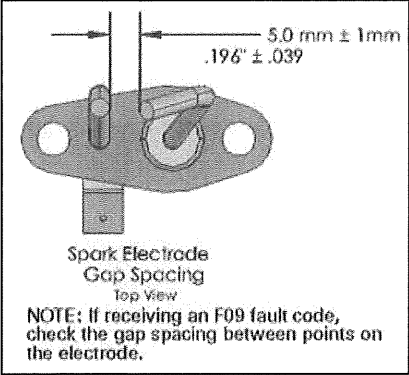
Fault Code F09		
<p>NO FLAME ON IGN F09 PUMP ON</p>	<p>The boiler tried to ignite four times during one heat call and failed. The red FAULT light and LOCKOUT will flash on the display. This code indicates a serious safety issue. The boiler will not restart until the cause of ignition failure is repaired by a technician and he pushes the RESET button on the display. During this lockout fault, the pump will remain on as indicated on the second line of the display.</p>	<ol style="list-style-type: none"> 1. Watch the igniter through the observation window provided. 2. If there is no spark, check the spark electrode for the proper .196" (5.0 mm ± 1mm) gap. 3. Remove any corrosion from the spark electrode and flame rectifier probe. 4. If there is a spark but no flame, check the gas supply to the boiler. 5. If there is a flame, check the flame sensor. 6. Check any flue blockage or condensate blocks.  <p>NOTE: If receiving an F09 fault code, check the gap spacing between points on the electrode.</p>
Fault Code F10		
<p>FLAME LOSS F10</p>	<p>The flame was lost while the boiler was firing 3 times during 1 demand call. The red light will display and the word LOCKOUT will flash. This code indicates a serious safety issue. The boiler will not restart until the cause of flame loss is determined by a technician and he pushes the RESET button on the display. During this lockout fault, the pump will be on as indicated on the second line of the display.</p>	<ol style="list-style-type: none"> 1. Monitor the gas pressure to the boiler while in operation. 2. Assure that the flame is stable when lit. 3. Check to see if the display readout changes from "GAS VALVE ON" to "RUN" within a few seconds after the boiler ignites. 4. Check the FLAME signal on the status display. It should be above 1.0 when the boiler is firing. 5. If the signal reads less than 1 microampere, clean the flame rectifier and spark probe. 6. If the problem persists and the "FLAME" signal is still less than 1.0, replace the flame probe and spark igniter probe. 7. The flame signal should be steady after the boiler has been firing for 1 minute and is normally at 5.0 to 9.0. If the flame signal is not steady, disassemble the burner door and check the burner and its sealing gaskets.
Fault Code F11		
<p>FALSE FLAME SIG F11 PUMP ON</p>	<p>There is flame when the control is not telling the boiler to run. The red light will display and the word LOCKOUT will flash. This code indicates a serious safety issue. The boiler will not restart until the cause is determined by a technician and he pushes the RESET button on the display. During this lockout fault, the pump will be on as indicated on the second line of the display.</p>	<ol style="list-style-type: none"> 1. Look into window. If there is flame, turn the gas off to the boiler at the service valve and replace the gas valve. 2. If the flame signal on the status menu is greater than 1.0 when the burner is not lit, replace the spark igniter and the flame rectification probe. 3. If the flame return sensor is not present after turning off the gas supply, check the gas valve electrical connection. 4. Repair condensate system as necessary. If condensate has backed up and partially filled the combustion chamber, the refractory wall may be damaged and should be replaced. 5. Turn the gas on at the service valve after corrective action is taken. 6. If the refractory wall falls against the rectifier probe, it may conduct the signal to ground, giving a false reading.

Fault Code F13		
FAN SPEED ERROR F13 PUMP ON	The fan is not running at the speed that the control has commanded it to run at. The fan speed had been more than 30% faster or slower than the commanded speed for more than 10 seconds. The red light will display and the word LOCKOUT will flash. This code indicates a serious safety issue and the boiler will not restart until the cause is determined by a technician and he pushes the RESET button on the display. During this lockout fault, the pump will be on as indicated on the second line.	1. Check the combustion air fan wiring. 2. Measure the DC voltage from the red fan wire to ground while it is connected to the fan. It should be between 24 to 40 volts. If it is lower than 24 volts, check for excessive external loads connected to the boiler sensor terminals. Disconnect the 5 pin plug from the fan and check the voltage on the red wire again. If it is now between 24-40 volts, replace the fan. If it is still below 24 volts replace the boiler control board.
Fault Code F20		
CONDENSATE FULL F20 PUMP ON	The condensate trap is full. The red light will display and the word LOCKOUT will flash. This code indicates a serious safety issue. The boiler will not restart until the cause is determined by a technician and he pushes the RESET button on the display. During this lockout fault, the pump will be off as indicated on the second line of the display.	1. Check condensate lines for obstructions. 2. Check float switch in condensate reservoir. 3. Check wiring from condensate reservoir to 926 control and repair as necessary.
Fault Code F31		
PROGRAM ERROR F31	There was an error while programming the control and the memory is corrupt. The boiler control will not function in this state and the pump will be off as indicated on the bottom line. This error only occurs if a technician is programming the control and the programming function fails. The only way to recover from this error is to reprogram the control. If this error occurs at any time other than when a technician is servicing the boiler, the control has failed and must be replaced by a qualified technician	The control must be re-programmed. If programming does not solve problem, the control must be replaced.
Fault Code PP		
CONTROL PROGRAMED PP	The control has been programmed by a technician or the factory. After programming, the control is left in a locked out mode. Press the RESET key for at least 1 second to begin use of the control.	
The following blocking codes will block operation until the control determines the situation safe for boiler operation.		
Blocking Code E07		
FLUE TEMP HIGH E07 PUMP OFF TIME	This display indicates that the flue sensor temperature is excessive and above 210°F. When this code is displayed, the boiler will not respond to a demand for heat. When the flue temperature decreases below 194°F, the display will return to normal and allow the boiler to respond to a heat demand. The bottom line indicates the status of the pump. The pump will remain off when this error is displayed.	Check the flue for obstructions or any sign of damage, especially signs of excessive heat. Repair as necessary. Run the boiler and check the flue temperature with an external thermometer. If the flue temperature on the thermometer does not agree with the flue temperature displayed in the status menu, inspect the wiring to the flue temperature sensor in the boiler and repair as necessary. If the wiring is intact, replace the flue sensor. If the flue temperature is excessive on the status menu and the test thermometer reads the same, check and adjust combustion controls on the boiler. If the problem persists, inspect the target wall in the combustion chamber and replace it if cracked or damaged.
Blocking Code E19		
LINE VOLTAGE PUMP OFF E19	This display indicates that the line voltage frequency is out of range. This could happen if the boiler is being powered from a small gasoline powered generator that is not functioning correctly or overloaded.	Inspect power wiring to boiler and repair as necessary. If connected to line voltage, notify the power company. If connected to an alternate power source such as generator or inverter, make sure the line voltage frequency supplied by the device is 60 Hz.

Table 26 – Fault and Blocking Code Screens

Resistance Tables		Supply Temperature Sensor 7250P-324	
Outdoor Sensor (7250P-319)		Boiler Sensor (7250P-667)	Indirect Sensor (7250P-325)
Outside Temperature (°F)	Resistance (ohms)	Water Temperature (°F)	Resistance (ohms)
-22	171800	32	32550
-13	129800	41	25340
-4	98930	50	19870
5	76020	59	15700
14	58880	68	12490
23	45950	77	10000
32	36130	86	8059
41	28600	95	6535
50	22800	104	5330
59	18300	113	4372
68	14770	122	3605
77	12000	131	2989
86	9804	140	2490
95	8054	149	2084
104	6652	158	1753
113	5522	167	1481
		176	1256
		185	1070
		194	915
		203	786
		212	667

Table 27

PART 12 – MAINTENANCE

A. MAINTENANCE PROCEDURES

Periodic maintenance should be performed once a year by a qualified service technician to assure that all the equipment is operating safely and efficiently. The owner should make necessary arrangements with a qualified heating contractor for periodic maintenance of the heater. The installer must also inform the owner that a lack of proper care and maintenance of the heater may result in a hazardous condition.

WARNING

BEFORE EACH HEATING SEASON a trained and qualified service technician should perform the inspections as per the boiler inspection and maintenance schedule in the back of the manual. Failure to do so could result in death or serious injury.

⚠ WARNING

The combustion chamber insulation in this product contains ceramic fiber material. Ceramic fibers can be converted to cristobalite in very high temperature applications. The International Agency for Research on Cancer (IARC) has concluded, "Crystalline silica inhaled in the form of quartz or cristobalite from occupational sources is carcinogenic to humans (Group 1)."

- Avoid breathing dust and contact with skin and eyes.
- Use NIOSH certified dust respirator (N95). This type of respirator is based on the OSHA requirements for cristobalite at the time this document was written. Other types of respirators may be needed depending on job site conditions. Current NIOSH recommendations can be found on the NIOSH website: <http://www.cdc.gov/niosh/homepage.html>. NIOSH approved respirators, manufacturers, and phone numbers are also listed on this website.
- Wear long-sleeved, loose fitting clothing, gloves, and eye protection.
- Apply enough water to the combustion chamber lining to prevent dust.
- Wash potentially contaminated clothes separately from other clothing. Rinse clothes washer thoroughly.

NIOSH stated First Aid.

- Eye: Irrigate immediately.
- Breathing: Fresh air.

B. COMBUSTION CHAMBER COIL CLEANING INSTRUCTIONS FOR BOILER

*Before beginning this procedure, you must have on hand the following items:

- a nylon, stainless steel or brass brush (not steel)
- an FDA approved liquid lime scale remover, in a spray bottle
- gloves and eye protection

1. Shut down the Boiler by using the following steps:

- a. Shut down the appliance. Close the gas valve. Wait for the appliance to be cool to the touch.
- b. Disconnect the condensate piping from the outside connection, (not from the Boiler side), so flow from condensate reservoir can be observed.
- c. Remove the front panel of the boiler by firmly pulling the panel toward you until it releases.
- d. Open the control door by turning the hand tightened nut counter-clockwise.
- e. Disconnect electrical connections from the gas valve, spark electrode, flame rectification probe and combustion blower.
- f. Remove the (4) screws on the aluminum $\frac{3}{4}$ " NPT connector on the right side of the gas valve.
- g. Disconnect the wiring connected to the combustion blower motor.
- h. Remove the (6) 10MM nuts from the burner plate assembly.

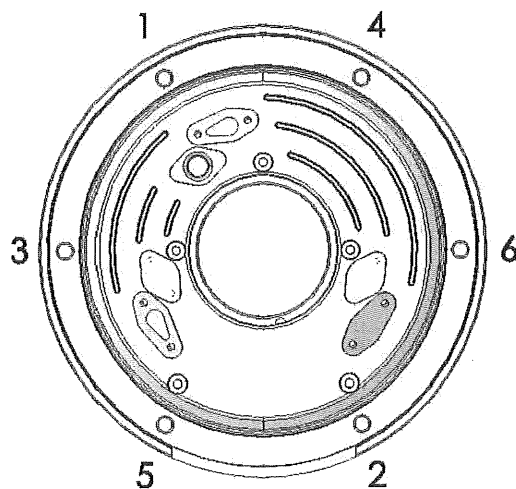

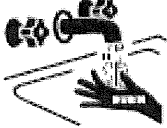

Figure 32

- i. Pull the entire burner plate assembly with blower still attached towards you. Remove or push aside any wiring to allow the removal of the assembly.
2. Using a spray bottle filled with the FDA approved lime scale remover, spray liberally on the coils, making sure the solution penetrates and funnels down through the condensate system. If the condensate system is blocked, let the chemical penetrate for at least 15 minutes or until it drains.
 3. Use the nylon, stainless steel or brass brush (do not use steel) and scrub coils to remove any buildup. Then vacuum the debris from the coils.
 4. Spray the coils with clear water, making sure to confine the spray to the area being cleaned (Try to avoid getting the back ceramic wall of the appliance wet). Flush the combustion chamber with fresh water until it runs clear from the condensate. At this point, the boiler should be ready to be re-assembled.
 - a. Inspect gaskets.
 - b. Re-install the burner assembly
 - c. Replace and tighten the (6) 10MM nuts to the burner plate using staggered tightening sequence. (See detail)
 - d. Re-connect all wiring connections
 - e. Inspect the gas valve to assure the O-ring is in place.
 - f. Replace the (4) screws on the aluminum connector on the gas valve. Turn the gas back on. (IMPORTANT: CHECK FOR GAS LEAKS!)
 - g. Re-secure the control door.
 - h. Replace the boiler front panel by aligning the four panel pins with the four jacket holes. Push firmly until the panel is secure.
 - i. Turn the Boiler power back on and create a demand on the boiler. When boiler is lit, observe condensate flow from the boiler. Be sure the boiler is operating properly.
 - j. Re-connect the condensate piping to the outside condensate connection.

C. CLEANING WATER SIDE OF HEAT EXCHANGER

⚠ DANGER		
⚠ DANGER	<p>Water temperature over 125 degrees F. can cause severe burns instantly, or death from scalds. Children, disabled, and elderly are at highest risk of being scalded. See instruction manual before setting temperature at water heater. Feel water before bathing or showering! Temperature limiting valves are available. See chart below showing temperature burn rate.</p>	⚠ DANGER
		

1. Make sure power is turned off to the boiler. Run water through the hot water system to assure it is below room temperature.
2. Close isolation valves on the return and supply connections to the boilers as shown in the piping diagrams within this manual. Slowly open the ball valves and release pressure into a bucket. Once pressure is released, connect a hose to the water line to flush the boiler. Scale removing solution may be used, but must be approved for use with stainless steel and FDA approved for use in a potable water system.
3. Thoroughly flush the heat exchanger before commissioning the unit back in service.

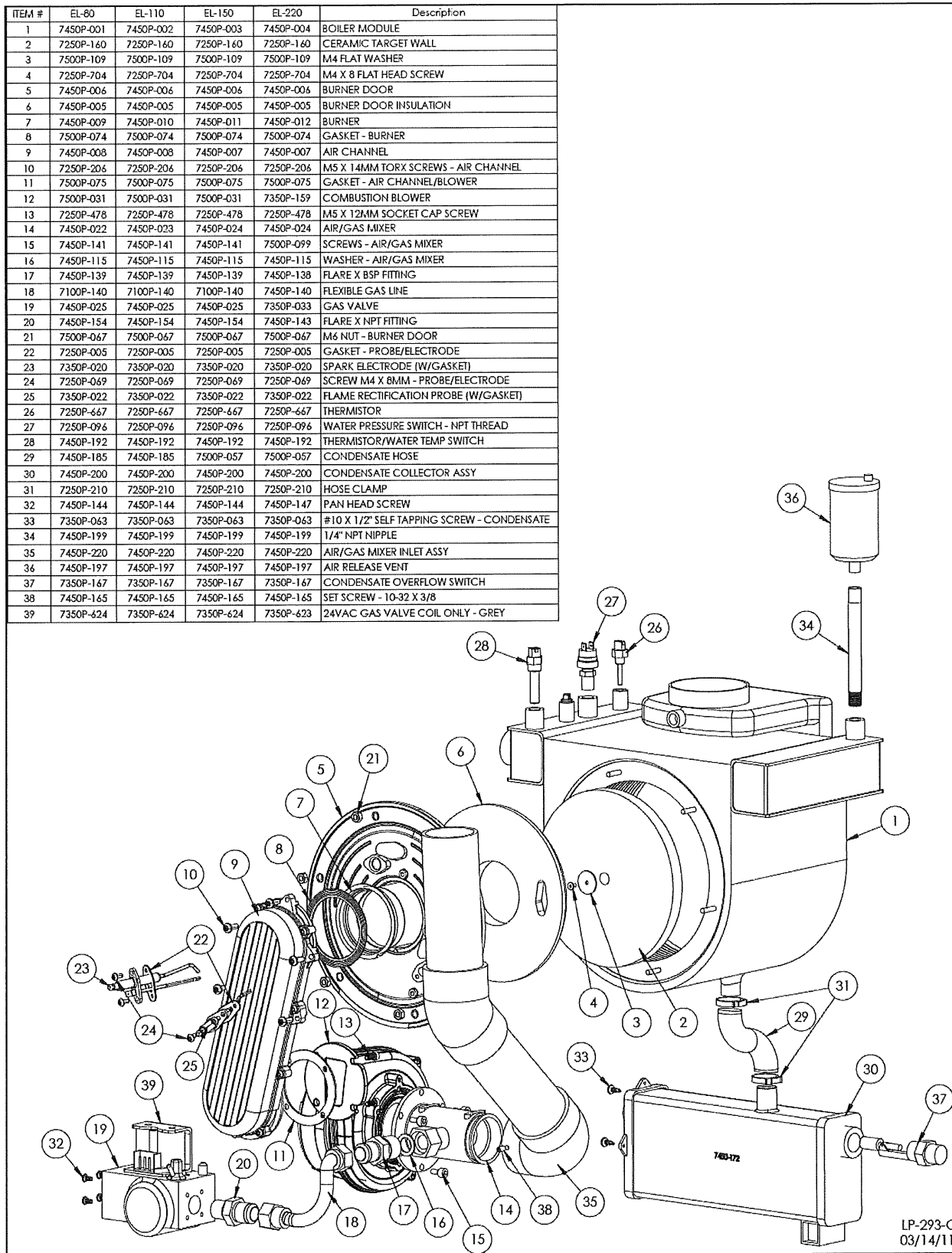
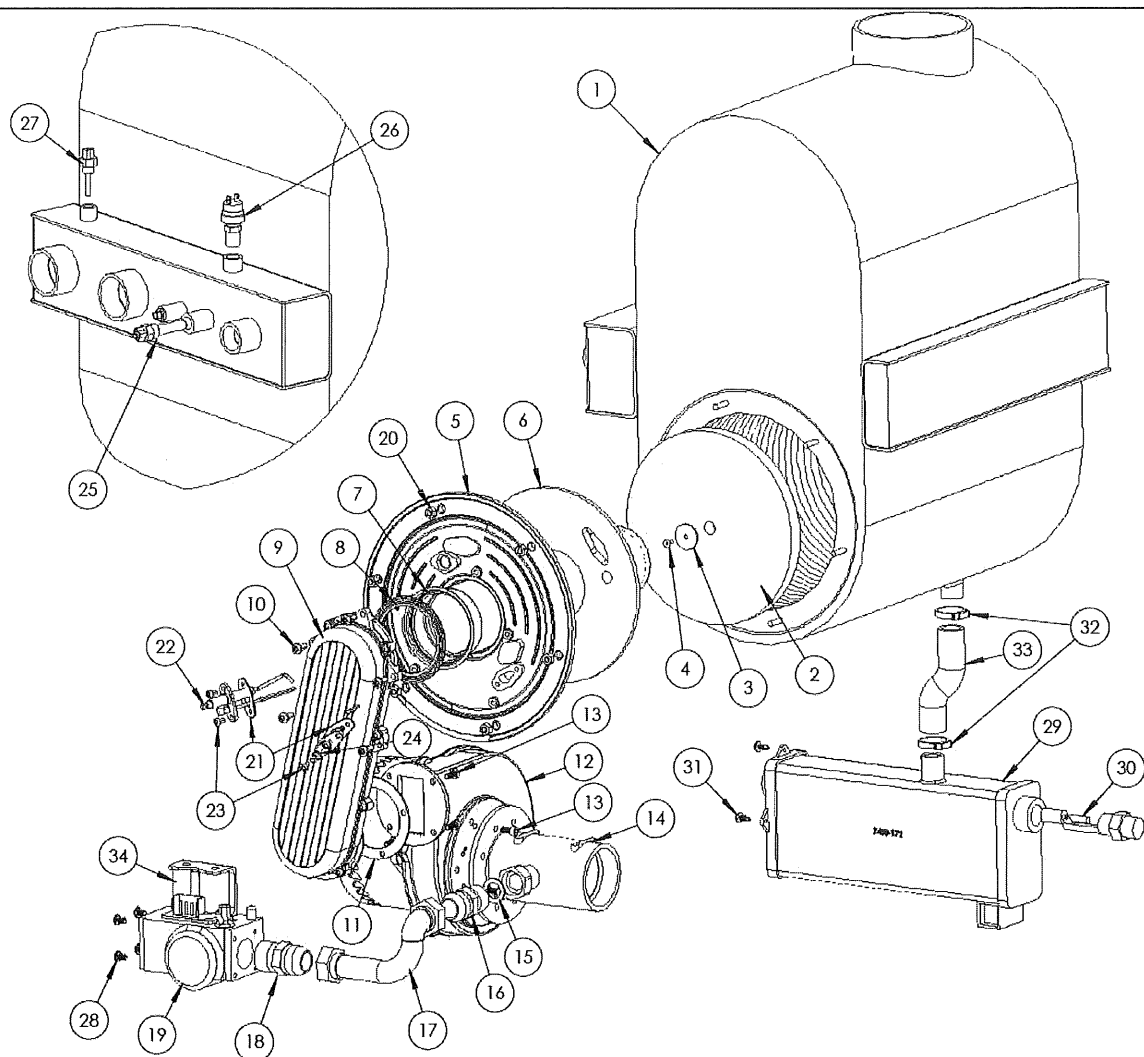

Figure 33

LP-293-N
01/25/11



Item No	EL-299	EL-399	Description	Item No	EL-299	EL-399	Description
1	7450P-014	7450P-015	BOILER MODULE	19	7350P-033	7350P-033	GAS VALVE
2	7250P-160	7250P-160	CERAMIC TARGET WALL	20	7500P-067	7500P-067	M6 NUT - BURNER DOOR
3	7500P-109	7500P-109	M4 FLAT WASHER - TARGET WALL	21	7250P-005	7250P-005	GASKET - PROBE/ELECTRODE
4	7250P-704	7250P-704	M4 X 8 FLAT HEAD SCREW - TARGET WALL	22	7350P-020	7350P-020	SPARK ELECTRODE (w/GASKET)
5	7450P-006	7450P-006	BURNER DOOR	23	7250P-069	7250P-069	SCREW M4 X 8MM - PROBE/ELECTRODE
6	7450P-005	7450P-005	BURNER DOOR INSULATION	24	7350P-022	7350P-022	FLAME RECTIFICATION PROBE (w/GASKET)
7	7350P-031	7350P-031	BURNER - GCFI	25	7450P-192	7450P-192	THERMISTOR/WATER TEMP SWITCH
8	7500P-074	7500P-074	GASKET - BURNER	26	7250P-096	7250P-096	WATER PRESSURE SWITCH - NPT THREAD
9	7450P-007	7450P-007	AIR CHANNEL	27	7250P-667	7250P-667	THERMISTOR
10	7250P-206	7250P-206	M5 X 14MM TORX SCREWS - AIR CHANNEL	28	7450P-147	7450P-147	M5 X 8MM PAN HEAD SCREW - GAS VALVE
11	7500P-075	7500P-075	GASKET - AIR CHANNEL/BLOWER	29	7450P-200	7450P-200	CONDENSATE COLLECTOR ASSY
12	7350P-159	7350P-159	COMBUSTION BLOWER	30	7500P-041	7500P-041	CONDENSATE OVERFLOW SWITCH
13	7250P-478	7450P-478	M5 X 12MM SOCKET CAP SCREW - MIXER/BLOWER	31	7350P-063	7350P-063	#10 x 1/2" SELF TAPPING SCREW - CONDENSATE
14	7450P-029	7450P-029	AIR GAS MIXER	32	7250P-210	7250P-210	HOSE CLAMP
15	7450P-115	7450P-115	WASHER - AIR/GAS MIXER	33	7500P-057	7500P-057	CONDENSATE HOSE
16	7450P-138	7450P-138	FLARE X BSP FITTING	34	7350P-623	7350P-623	24VAC GAS VALVE COIL ONLY - GREY
17	7450P-140	7450P-140	FLEXIBLE GAS LINE				
18	7450P-143	7450P-143	FLARE X NPT FITTING				

Figure 34

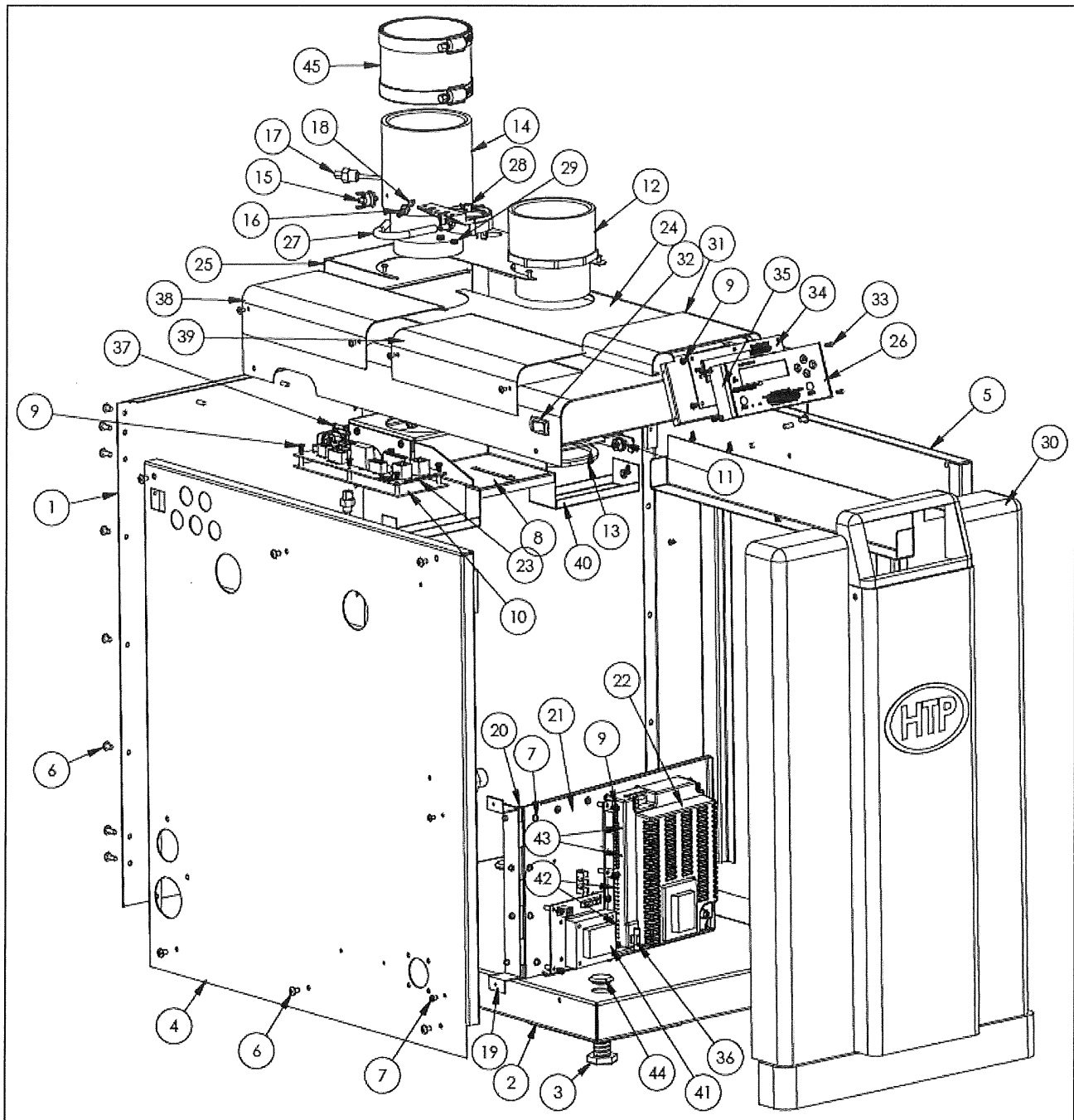

Figure 35 – LP-293-A

NOTE: Parts listed on the following page.

ITEM#	EL-80	EL-110	EL-150	EL-220	EL-299	EL-399	DESCRIPTION
1	7450P-039	7450P-039	7450P-039	7450P-039	7450P-065	7450P-065	JACKET - REAR
2	7450P-055	7450P-055	7450P-056	7450P-038	7450P-064	7450P-068	JACKET - BOTTOM
3	7450P-121	7450P-121	7450P-121	7450P-121	7450P-121	7450P-121	LEVELING FEET
4	7450P-057	7450P-059	7450P-060	7450P-036	7450P-061	7450P-066	JACKET - LEFT SIDE
5	7450P-058	7450P-123	7450P-062	7450P-037	7450P-063	7450P-067	JACKET - RIGHT SIDE
6	7450P-080	7450P-080	7450P-080	7450P-080	7450P-080	7450P-080	10-32 X 5/16 PAN HEAD SCREW - JACKET
7	7450P-081	7450P-081	7450P-081	7450P-081	7450P-081	7450P-081	6-32 X 1/4 PAN HEAD SCREW - ACCESSORIES
8	7450P-074	7450P-074	7450P-074	7450P-074	7450P-075	7450P-075	AIR/EXHAUST SUPPORT PLATE
9	7500P-115	7500P-115	7500P-115	7500P-115	7500P-115	7500P-115	6-32 X 1/4 PAN HEAD SCREW - ELECTRONIC BOARDS
10	7450P-178	7450P-178	7450P-178	7450P-178	N/A	N/A	FIELD CONNECTION BOARD PLATE
11	7450P-088	7450P-088	7450P-088	7450P-088	7450P-088	7450P-088	8-32 FLANGED NUT - AIR EXHAUST PLATE
12	7450P-030	7450P-030	7450P-030	7450P-030	7450P-031	7450P-031	AIR INLET ADAPTER
13	7450P-032	7450P-032	7450P-032	7450P-032	7450P-033	7450P-033	AIR INLET CONNECTOR NUT
14	7450P-201	7450P-201	7450P-201	7450P-201	7450P-202	7450P-202	EXHAUST ADAPTER
15	7250P-739	7250P-739	7250P-739	7250P-739	7250P-739	7250P-739	ECO FLUE SWITCH - 160 DEGREES
16	7250P-154	7250P-154	7250P-154	7250P-154	7250P-154	7250P-154	S.S. BARBED FITTING - 1/4 HOSE X 10-32
17	7450P-026	7450P-026	7450P-026	7450P-026	7450P-026	7450P-026	FLUE THERMISTOR
18	7250P-152	7250P-152	7250P-152	7250P-152	7250P-152	7250P-152	SILICONE O-RING 2-007 - BARBED FITTING
19	7450P-079	7450P-079	7450P-079	7450P-079	7450P-079	7450P-079	HINGE BRACKET
20	7450P-091	7450P-091	7450P-091	7450P-091	7450P-091	7450P-091	HINGE
21	7450P-132	7450P-132	7450P-132	7450P-132	7450P-132	7450P-132	CONTROL BOARD DOOR W/HINGE
22	7450P-122	7450P-122	7450P-122	7450P-122	7450P-122	7450P-122	926 CONTROL BOARD
23	7350P-070	7350P-070	7350P-070	7350P-070	7350P-070	7350P-070	FIELD CONNECTION BOARD
24	7450P-040	7450P-040	7450P-041	7450P-042	7450P-043	7450P-044	JACKET - TOP COVER FRONT
25	7450P-072	7450P-072	7450P-099	7450P-099	7450P-073	7450P-073	JACKET - TOP COVER BACK
26	7450P-021	7450P-021	7450P-021	7450P-021	7450P-021	7450P-021	MEMBRANE TOUCHPAD
27	7000P-805	7000P-805	7000P-805	7000P-805	7000P-805	7000P-805	PLASTIC TUBING - 3/16 OD - BLOCKED VENT PRESSURE SWITCH
28	7250P-150	7250P-150	7250P-150	7250P-150	7250P-150	7250P-150	BLOCKED VENT PRESSURE SWITCH
29	7450P-142	7450P-142	7450P-142	7450P-142	7450P-142	7450P-142	6-32 FLANGED NUT - BLOCKED VENT PRESSURE SWITCH
30	7450P-046	7450P-046	7450P-046	7450P-046	7450P-051	7450P-051	JACKET - FRONT COVER ASSY
31	7450P-045	7450P-045	7450P-045	7450P-045	7450P-045	7450P-045	JACKET - TOP COVER INSERT
32	7500P-087	7500P-087	7500P-087	7500P-087	7500P-087	7500P-087	POWER SWITCH
33	7450P-092	7450P-092	7450P-092	7450P-092	7450P-092	7450P-092	6-32 FLAT HEAD SCREW - ACCESSORIES
34	7450P-028	7450P-028	7450P-028	7450P-028	7450P-028	7450P-028	DISPLAY BOARD
35	7450P-018	7450P-018	7450P-018	7450P-018	7450P-018	7450P-018	MEMBRANE SWITCH BRACKET
36	7250P-378	7250P-378	7250P-378	7250P-378	7250P-378	7250P-378	FUSE - CONTROL BOARD - 6.3 AMPS
37	7350P-129	7350P-129	7350P-129	7350P-129	7350P-129	7350P-129	FUSE - CONNECTION BOARD - 3.15 AMPS
38	7450P-160	7450P-160	7450P-160	7450P-160	7450P-160	7450P-160	FIELD CONNECTION BOARD COVER
39	N/A	N/A	N/A	7450P-061	N/A	N/A	BOILER ACCESS COVER
40	7450P-076	7450P-076	7450P-076	7450P-076	7450P-077	7450P-077 (2)	MODULE HOLD-DOWN STRAP
41	N/A	N/A	N/A	7450P-221	7450P-221	7450P-221	TRANSFORMER ASSEMBLY
42	7450P-204	7450P-204	7450P-204	7450P-208	7450P-209	7450P-210	120V WIRING HARNESS (NOT SHOWN)
43	7450P-203	7450P-203	7450P-203	7450P-205	7450P-206	7450P-207	LOW VOLTAGE WIRING HARNESS (NOT SHOWN)
44	7450P-226	7450P-226	7450P-226	7450P-226	7450P-226	7450P-226	7/8 HOLE PLUG
45	7450P-282	7450P-282	7450P-282	7450P-282	7450P-157	7450P-157	CLAMP ALL - EXHAUST VENT ADAPTER

BOILER START-UP REPORT

LIGHT OFF ACTIVITIES		DATE COMPLETED			
1) Fill the heating system	Check all piping and gas connections, verify all are tight				
	Pressurize system (12 – 15 psi)	___ PSI			
	Add water to prime condensate cup				
	Percentage of glycol in system (0 – 50%)	___ %			
	Verify near boiler piping is properly supported				
2) Check gas pipe	Leak test using locally approved methods (consult jurisdictional code book)				
	Check incoming gas pressure (3.5" to 14" W.C.)	___ in w.c.	Static		
	What is the "drop" on light off (No more than 1" W.C.)?	___ in w.c.	Dynamic		
3) Check combustion	Check and adjust (if necessary) carbon dioxide content	___% CO ₂	High Fire	___% CO ₂	Low Fire
	Check and adjust (if necessary) carbon monoxide content	___ppm CO	High Fire	___ppm CO	Low Fire
4) Verify system operation	Turn up thermostat to verify wiring connections				
5) Record ionization current	Check uA reading at d7 on the status menu (see start-up section)	___ uA	High Fire	___ uA	Low Fire
6) Indirect water heater	Verify safety and operation of the indirect water heater, record settings	___de	___dh		
7) Convert the boiler	If necessary, convert the boiler to the proper gas type				
	Locate the stickers in the appropriate locations on the boiler				
	Verify combustion settings after gas conversion, Carbon Dioxide	___% CO ₂	High Fire	___% CO ₂	Low Fire
	Verify combustion settings after gas conversion, Carbon Monoxide	___ppm CO	High Fire	___ppm CO	Low Fire
	Mail in the conversion registration				
8)Record system settings	Record heating curve, record steps	___*8	___*9	___*10	___*11
Notes:					

Table 28

MAINTENANCE REPORT

Periodic maintenance should be performed once a year by a qualified service technician to assure that all the equipment is operating safely and efficiently. The owner should make necessary arrangements with a qualified heating contractor for periodic maintenance of the boiler. Installer must also inform the owner that the lack of proper care and maintenance of the boiler may result in a hazardous condition.

INSPECTION ACTIVITIES		DATE LAST COMPLETED			
		1 st YEAR	2 nd YEAR	3 rd YEAR	4 th YEAR*
PIPING					
Near boiler piping	Check boiler and system piping for any sign of leakage; make sure they are properly supported.				
Vent	Check condition of all vent pipes and joints.				
Gas	Check Gas piping, test for leaks and signs of aging. Make sure all pipes are properly supported.				
SYSTEM					
Visual	Do a full visual inspection of all system components.				
Functional	Test all functions of the system (Heat, Safeties)				
Temperatures	Verify safe settings on boiler or Anti-Scald Valve				
Temperatures	Verify programmed temperature settings				
ELECTRICAL					
Connections	Check wire connections. Make sure they are tight.				
Smoke and CO detector	Verify devices are installed and working properly. Change batteries if necessary.				
Circuit Breakers	Check to see that the circuit breaker is clearly labeled. Exercise circuit breaker.				
Switch and Plug	Verify ON/OFF switch and convenience plug are both functional				
CHAMBER/BURNER					
Combustion Chamber	Check burner tube and combustion chamber coils. Clean according to maintenance section of manual. Vacuum combustion chamber.				
Spark Electrode	Clean. Set gap at 1/4"				
Flame Probe	Clean. Check ionization in uA (d7 on status menu in Start-up Procedures). Record high fire and low fire.				
CONDENSATE					
Neutralizer	Check condensate neutralizer. Replace if necessary.				
Condensate hose	Disconnect condensate hose. Clean out dirt. Fill with water to level of outlet and re-install. (NOTE: Verify the flow of condensate, making sure that the hose is properly connected during final inspection.)				
GAS					
Pressure	Measure incoming gas pressure (3.5" to 14" W.C.)				
Pressure Drop	Measure drop in pressure on light off (no more than 1" W.C.)				
Check gas pipe for leaks	Check piping for leaks. Verify that all are properly supported.				
COMBUSTION					
CO/CO2 Levels	Check CO and CO2 levels in Exhaust (See Start-up Procedures for ranges). Record at high and low fire.				
SAFETIES					
ECO (Energy Cut Out)	Check continuity on Flue and Water ECO. Replace if corroded.				
Thermistors	Check wiring. Verify through ohms reading.				
FINAL INSPECTION					
Check list	Verify that you have completed entire check list. WARNING: FAILURE TO DO SO COULD RESULT IN SERIOUS INJURY OR DEATH.				
Homeowner	Review what you have done with the homeowner.				
TECH SIGN OFF					

Table 29 - *Continue annual maintenance beyond the 4th year as required.

<p>ADDITIONAL INSTALLATION REQUIREMENTS FOR THE COMMONWEALTH OF MASSACHUSETTS</p>
--

In the Commonwealth of Massachusetts, the installer or service agent shall be a plumber or gas fitter licensed by the Commonwealth.

When installed in the Commonwealth of Massachusetts or where applicable state codes may apply; the unit shall be installed with a CO detector per the requirements listed below.

5.08: Modifications to NFPA-54, Chapter 10

(1) Revise NFPA-54 section 10.5.4.2 by adding a second exception as follows:

Existing chimneys shall be permitted to have their use continued when a gas conversion burner is installed, and shall be equipped with a manually reset device that will automatically shut off the gas to the burner in the event of a sustained back-draft.

(2) Revise 10.8.3 by adding the following additional requirements:

(a) For all side wall horizontally vented gas fueled equipment installed in every dwelling, building or structure used in whole or in part for residential purposes, including those owned or operated by the Commonwealth and where the side wall exhaust vent termination is less than seven (7) feet above finished grade in the area of the venting, including but not limited to decks and porches, the following requirements shall be satisfied:

1. INSTALLATION OF CARBON MONOXIDE DETECTORS. At the time of installation of the side wall horizontal vented gas fueled equipment, the installing plumber or gasfitter shall observe that a hard wired carbon monoxide detector with an alarm and battery back-up is installed on the floor level where the gas equipment is to be installed. In addition, the installing plumber or gasfitter shall observe that a battery operated or hard wired carbon monoxide detector with an alarm is installed on each additional level of the dwelling, building or structure served by the side wall horizontal vented gas fueled equipment. It shall be the responsibility of the property owner to secure the service of qualified licensed professionals for the installation of hard wired carbon monoxide detectors

a. In the event that the side wall horizontally vented gas fueled equipment is installed in a crawl space or an attic, the hard wired carbon monoxide detector with alarm and battery back-up may be installed on the next adjacent floor level.

b. In the event that the requirements of this subdivision cannot be met at the time of completion of installation, the owner shall have a period of thirty (30) days to comply with the above requirements; provided, however, that during said thirty (30) day period, a battery operated carbon monoxide detector with an alarm shall be installed.

2. APPROVED CARBON MONOXIDE DETECTORS. Each carbon monoxide detector as required in accordance with the above provisions shall comply with NFPA 720 and be ANSI/UL 2034 listed and IAS certified.

3. SIGNAGE. A metal or plastic identification plate shall be permanently mounted to the exterior of the building at a minimum height of eight (8) feet above grade directly in line with the exhaust vent terminal for the horizontally vented gas fueled heating appliance or equipment. The sign shall read, in print size no less than one-half (1/2) inch in size, "GAS VENT DIRECTLY BELOW, KEEP CLEAR OF ALL OBSTRUCTIONS".

4. INSPECTION. The state or local gas inspector of the side wall horizontally vented gas fueled equipment shall not approve the installation unless, upon inspection, the inspector observes carbon monoxide detectors and signage installed in accordance with the provisions of 248 CMR 5.08 (2)(a) 1 through 4.

(b) EXEMPTIONS: the following equipment is exempt from 248 CMR 5.08 (2)(a) 1 through 4:

1. The equipment listed in Chapter 10 entitled "Equipment Not Required to be Vented" in the most current edition of NFPA 54 as adopted by the Board; and
2. Product Approved side wall horizontally vented gas fueled equipment installed in a room or structure separate from the dwelling, building or structure used in whole or in part for residential purposes.

(c) MANUFACTURER REQUIREMENTS – GAS EQUIPMENT VENTING SYSTEM PROVIDED. When the manufacturer of Product Approved side wall horizontally vented gas equipment provides a venting system design or venting system components with the equipment, the instructions provided by the manufacturer for installation of the equipment and the venting system shall include:

1. Detailed instructions for the installation of the venting system design or the venting system components; and
2. A complete parts list for the venting system design or venting system.

(d) MANUFACTURER REQUIREMENTS – GAS EQUIPMENT VENTING SYSTEM NOT PROVIDED. When the manufacturer of a Product Approved side wall horizontally vented gas fueled equipment does not provide the parts for venting the flue gases, but identifies "special venting systems", the following requirements shall be satisfied by the manufacturer:

1. The referenced "special venting system" instructions shall be included with the appliance or equipment installation instructions; and
2. The "special venting systems" shall be Product Approved by the Board, and the instructions for that system shall include a parts list and detailed installation instructions.

(e) A copy of all installation instructions for all Product Approval side wall horizontally vented gas fueled equipment, all venting instructions, all parts lists for venting instructions, and/or all venting design instructions shall remain with the appliance or equipment at the completion of the installation.

HTP CUSTOMER INSTALLATION RECORD FORM

The following form should be completed by the installer for you to keep as a record of the installation in case of a warranty claim. After reading the important notes at the bottom of the page, please also sign this document.

Customer's Name:	
Installation Address:	
Date of Installation:	
Installer's Code/Name:	
Product Serial Number(s):	
Combustion Setting at Time of Installation:	
Comments:	
Installer's Phone Number:	
Signed by Installer:	
Signed by Customer:	

IMPORTANT NOTES:

Customer: Please only sign after the installer has reviewed the installation, safety, proper operation and maintenance of the system. In the case that the system has any problems, please call the installer. If you are unable to make contact, please contact your HTP Sales Representative.

Distributor/Dealer: Please insert contact details.

SCALE 1/8"=1'
SCALE 1/16"=1'

BOILER PERFORMANCE SCHEDULE

TAG	HE-R RATING GROSS NET	DOE NET (FEB)	FUEL	HEATING EFFIC.	BOILER SECTN	ELECTRICAL REQUIREMENTS	BASIS OF DESIGN	HYP Products "Mudkat"
						HP WATTS	V/F/PHZ	BURNER MAKE BURNER MODEL
EB1	37.0	37.0	NG	83%	-	-	D0160	HUBR - - - - - 3991

AIR SEPARATOR PERFORMANCE SCHEDULE

TAG	FLOW RATE (GPM)	UP/D	CV FACTOR	STRAINER (Y) OR (N)	MAX WORKING TEMPERATURE (DEGREE F)	MAX WORKING PRESSURE (PSI)	SERVICE	PIPE SIZE (IN)	MODEL
AB1	25.0	1.4	-	N	730	50	HUBR	1/2	4500 A-D
AB2	4.0	1.4	-	N	730	50	SNOWMELT	1	43-1

WALL UNIT HEATER PERFORMANCE SCHEDULE

TAG	OUTPUT (BTU)	FLOW RATE (GPM)	UP/D (FT/IN)	AIRFLOW (CFM)	HTRCU	HTRHT.	ELECTRICAL REQUIREMENTS	BASIS OF DESIGN (BT) Sterling, (G) Greenheck
							HP WATTS	V/F/PHZ
UH1	6.7	1.0	-	50	-	-	50	D0160
UH2	45.0	3.0	0.0	550	30"	84"	10	D0160
UH3	45.0	3.0	0.0	550	30"	84"	10	D0160
UH4	7.1	1.0	-	50	-	-	50	D0160

EXPANSION TANK PERFORMANCE SCHEDULE

TAG	TANK VOLUME (GAL)	ACCEPTANCE VOLUME (GAL)	MIN. REQ'D. ACCEPT. VOL. (GAL)	MAX. WORKING TEMPERATURE (DEGREE F)	MAX. WORKING PRESSURE (PSI)	WEIGHT (LBS)	BASIS OF DESIGN (T) TACO, (A) AIRTRON
							MOUNTING FLOOR SERVICE MODEL
ET1	51.0	51.0	51.0	240	25	250	FLOOR HUBR (T) CA-25
ET2	8.0	5.0	3.6	240	25	105	FLOOR SNOWMELT (T) CBX-42

PUMP PERFORMANCE SCHEDULE

TAG	FLOW RATE (GPM)	HEAD (FT/IN)	PIPE SIZE	RF1	EFF %	ELECTRICAL REQUIREMENTS	BASIS OF DESIGN (T) TACO, (U) ULLO "TRATOR"
						HP BHP VFD AMP'S	SERVICE ARRANGEMENT MODEL
CP1	25.0	10.0	-	TDS	-	1/2 - - - 1.5	D0160 BOILER PUMP N-LINE (T) 2400-40
CP2	25.0	24.0	-	TDS	-	1/2 - - - 200/2160	STRETCH PUMP N-LINE (U) 1.25 x 3-35-3
CP3	4.0	25.0	-	3450	-	1/2 - - - 1.5	D0160 SNOWMELT N-LINE (T) 2400-30

FAN PERFORMANCE SCHEDULE

TAG	AIRFLOW (CFM)	TAP (IN/IN)	NOISE (dBA)	FRM	DRIVE	ELECTRICAL REQUIREMENTS	BASIS OF DESIGN (P) PANASONIC, (G) GREENHECK
						HP BHP WATTS AMP'S	SERVICE ARRANGEMENT MODEL
EF-T	80	0.1	0.3	TB	DIRECT	- - - 25.2	D0160 TOILETS CEILING (P) PV-20V23
EF1	7100	0.1	0.3	ST1	BELT	1/2 0.4 - - 9.8	D0160 MAINTENANCE BAY SIDEWALL (G) QUB-161-5
EF2	7100	0.1	0.3	ST1	BELT	1/2 0.35 - - 7.2	D0160 CAR WASH BAY SIDEWALL (G) QUB-141-3

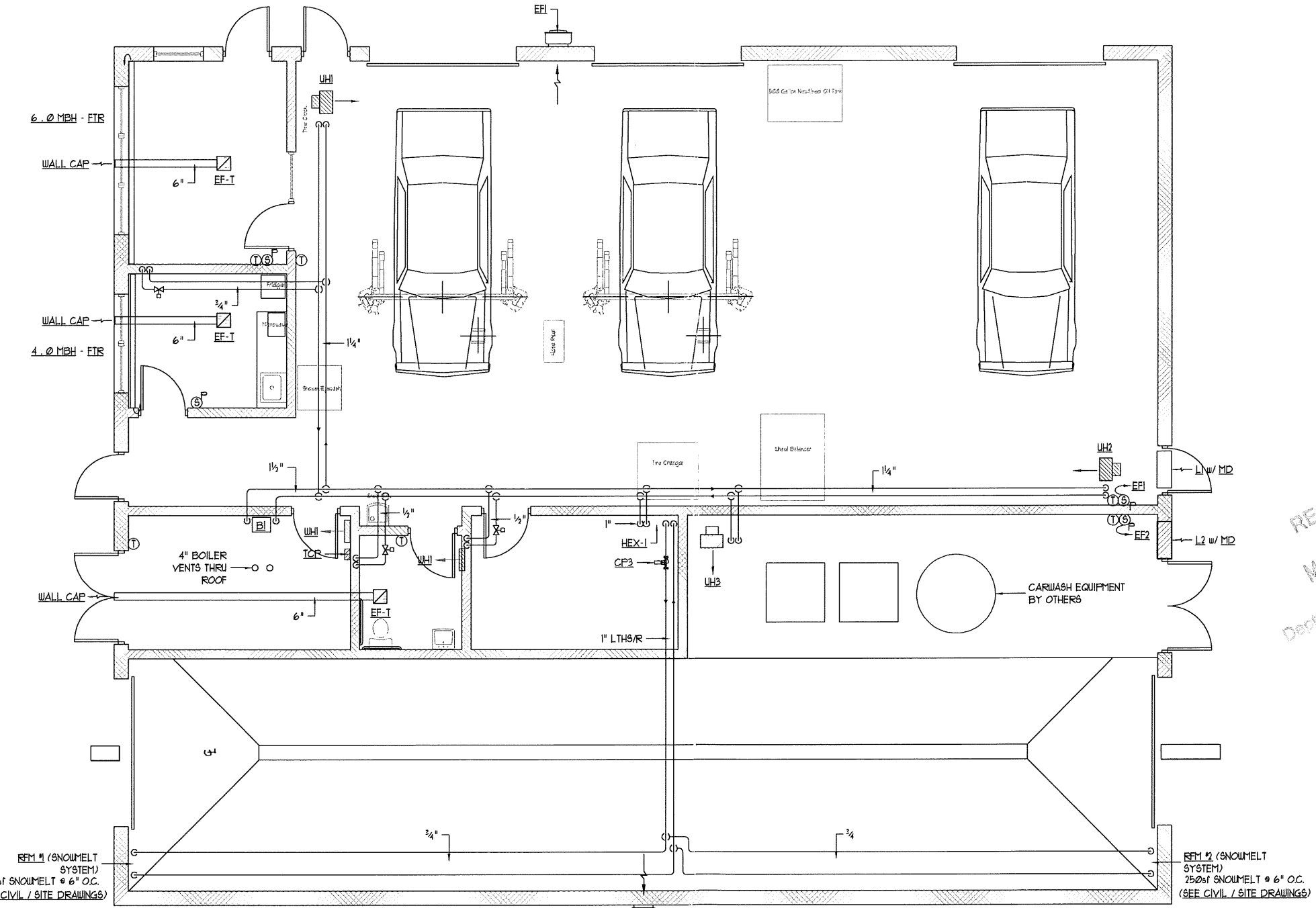

CONVECTOR / FIN TUBE PERFORMANCE SCHEDULE

TAG	OUTPUT (BTU/FT)	FLOW RATE (GPM)	MOUNTING HEIGHT (IN)	ENCLOSURE HEIGHT (IN)	ENCLOSURE LENGTH (FT)	ELEMENT LENGTH (FT)	CONTROL VALVE	BASIS OF DESIGN STERLINGS
								TUBE SIZE (IN) FIN FOOT NO. OF TIERS MODEL
FTR	0.70	2.0	14	11	-	-	V-5	3/4 50 1 JVC-01

LOUVER PERFORMANCE SCHEDULE

TAG	AIR FLOW (CFM)	SP LOSS (IN. W.G.)	AIR VEL. (FT/HR)	SIZE (INCHES) (WxH)	FREE AREA (SQ. FT)	DRAINABLE (Y) OR (N)	BLADE ANGLE (DEGREE)	FRAME DEPTH	BASIS OF DESIGN RUBIK
									SERVICE MODEL BLANK-OFF PANEL
L1	7100	.05	-	30"x30"	3.1	Y	35°, 6"	-	EF1 INTAKE ELF637BOX N
L2	7100	.05	-	30"x30"	3.1	Y	35°, 6"	-	EF2 INTAKE ELF637BOX N

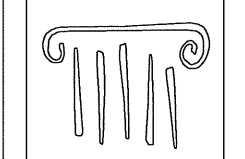
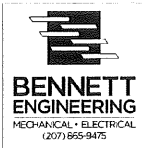

65 NEWBURY STREET
PORTLAND, ME 04101
207.761.9000
fax: 207.761.2010
info@portcityarch.com



FOR CONSTRUCTION

CONSULTANTS:
Structural Integrity
Consulting Engineers Inc.
77 Oak Street
Portland, Maine 04101
(207) 774-4614
contact: Aaron C. Jones, P.E.
aaron@structuralinteg.com

Bennett Engineering
7 Bennett Road
Freeport, Maine 04037
(207) 865-9475
contact: Will Bennett, P.E.
will@bennettengineering.net

Portland Pump Company
9 Border Road
Scarborough, Maine 04070
(207) 883-4317
contact: Charlie Wilson
charlie@portlandpump.com

RECEIVED
MAR 12 2012
Dept. of Building Inspections
City of Portland, Maine

Enterprise Rent-a-Car
1128 Westbrook Street
Portland, Maine

REVISIONS

#	DATE	DESCRIPTION
1	9-1-11	BID SET
2	9-9-11	FOR CONSTRUCTION

Date Issued: SEPTEMBER 9, 2011

Project Number: 11101

Drawing Scale:

SHEET NAME: HVAC Plan and Schedules

Drawn By: SP Doel
Checked By: SP Doel

BOILER PERFORMANCE SCHEDULE										
TAG	1-1/2" R RATING GROSS NET	DOE RTR (FEB)	REL. THERM EFFIC	BOILER RECTNS	ELECTRICAL REQUIREMENTS HP WATTS	V/F/PHZ	SERVICE	BURNER MAKE	BURNER MODEL	MODEL
B1	3T.0	3T.0	-	N3	33A	-	DVA/60	HUBR	-	399T

AIR SEPARATOR PERFORMANCE SCHEDULE									
TAG	FLOW RATE (GPM)	W/PD (PSIG)	CV FACTOR	STRANS (T) OR (N)	MAX WORKING TEMPERATURE (DEGREES F)	MAX WORKING PRESSURE (PSI)	SERVICE	PIPE SIZE (IN)	MODEL
AS1	20.0	1.4	-	N	710	50	HUBR	1 1/2	4508 A-D
AS2	4.0	1.4	-	N	710	50	SHOUFELT	1	49-1

WALL 4 UNIT HEATER PERFORMANCE SCHEDULE											
TAG	OUTPUT (BTU)	FLOW RATE (GPM)	W/PD (PSIG)	INLET/OUT (IN)	THROW	HEIGHT	HP WATTS	V/F/PHZ	SERVICE	ARRANGEMENT	MODEL
WH1	6.1	1.0	-	80	-	-	60	DVA/60	-	Wall Heater	(6) K500-06
WH2	45.0	3.0	0.0	950	30'	84"	18	DVA/60	-	HORIZONTAL	(5T) H8-T2
WH3	45.0	3.0	0.0	950	30'	84"	18	DVA/60	-	HORIZONTAL	(5T) H8-T2
WH4	12.1	4.0	0.0	750	40'	144"	18	DVA/60	-	HORIZONTAL	(5T) H8-20

EXPANSION TANK PERFORMANCE SCHEDULE											
TAG	TANK VOLUME (GAL)	ACCEPTANCE VOL (GAL)	MIN. REQD. ACCEPT VOL (GAL)	MAX WORKING TEMPERATURE (DEG F)	MAX WORKING PRESSURE (PSI)	WEIGHT (LBS)	BASIS OF DESIGN (T) TAGO, (A) AIRTEL				
ET1	51.0	51.0	51.0	240	25	250	FLOOR	SERVICE	HUBR	MODEL	(T) CA-2B
ET2	1.0	5.0	3.0	240	25	105	FLOOR	ENCUMBE	(T) CBX-2		

PUMP PERFORMANCE SCHEDULE													
TAG	FLOW RATE (GPM)	HEAD (FT/AG)	PIPE SIZE	RPM	EFF %	HP	ENP	VFD	A/P/S	V/F/PHZ	BASIS OF DESIGN (T) TAGO, (N) WLO "STRATOR"		
CP1	25.0	10.0	-	TDS	-	1/6	-	-	1.5	DVA/60	BOILER PUMP	N-LINE	(T) 2400-40
CP2	25.0	24.0	-	TDS	-	1/4	-	-	200/240	DVA/60	SYSTEM PUMP	N-LINE	(N) 1.25 x 3-30-3
CP3	4.0	25.0	-	3450	-	1/2	-	-	1.5	DVA/60	ENCUMBE	N-LINE	(T) 2400-30

FAN PERFORMANCE SCHEDULE													
TAG	AIRFLOW (CFM)	TAP (IN/SG)	NOISE (dBA)	RPM	DRIVE	HP	ENP	WATTS	A/P/S	V/F/PHZ	BASIS OF DESIGN (P) PANASONIC, (G) GREENHECK		
EF-T	60	0.1	0.3	TB	DIRECT	-	-	25.1	-	DVA/60	TOILETS	CEILING	(P) FV-6043
EF1	2100	0.1	0.3	ST1	BELT	1/4	0.4	-	5.0	DVA/60	MAINTENANCE BAY	SIDEWALL	(G) CUB-141-5
EF2	2100	0.1	0.0	ST1	BELT	1/3	0.35	-	7.2	DVA/60	CAR WASH BAY	SIDEWALL	(G) CUB-141-3

Note: All fans shall have gravity backdraft dampers.

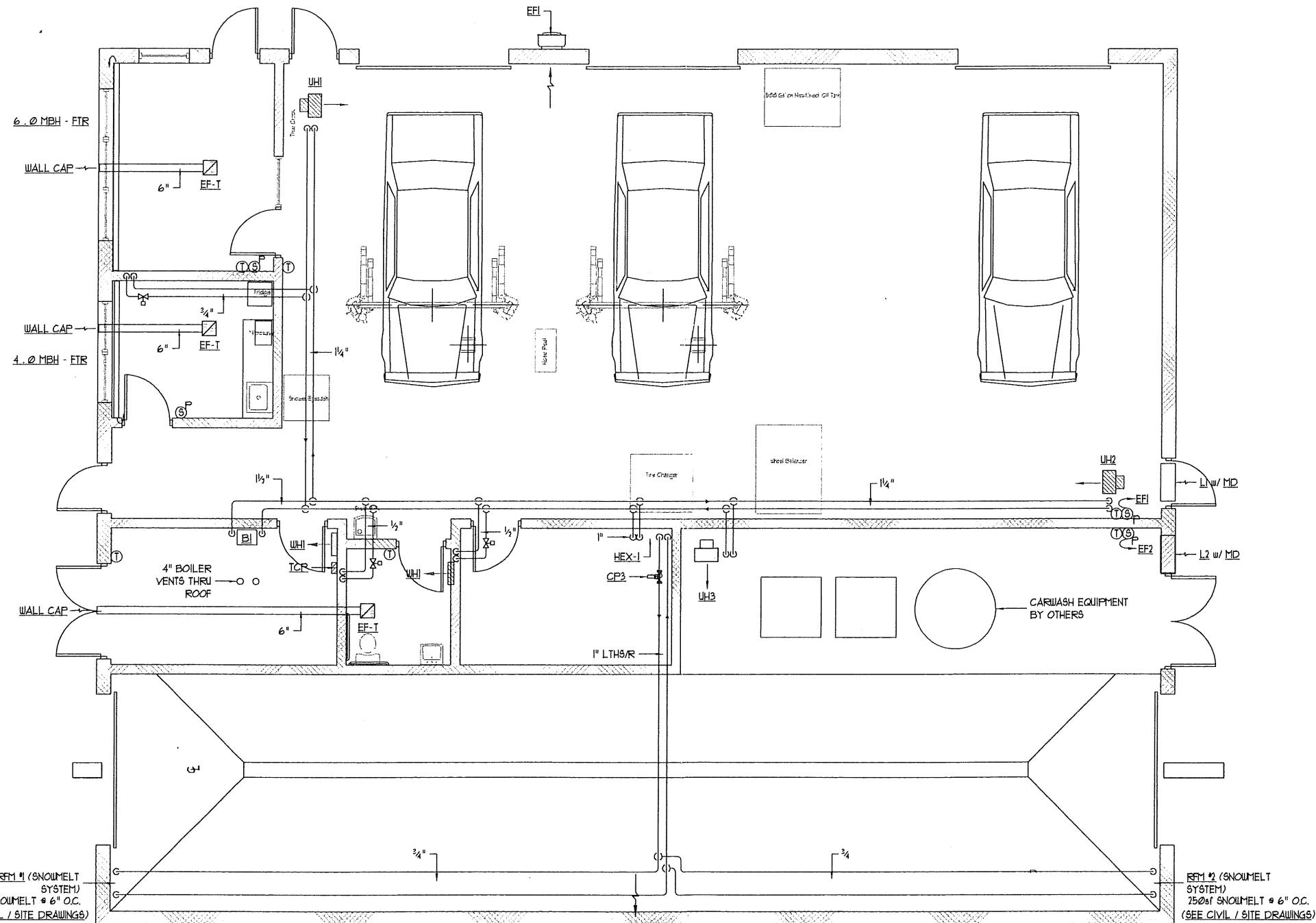

CONNECTOR / FIN TUBE PERFORMANCE SCHEDULE											
TAG	OUTPUT (BTU/FT)	FLOW RATE (GPM)	HEIGHT (IN)	ENCLOSURE HEIGHT (IN)	ENCLOSURE LENGTH (FT)	ELEMENT LENGTH (FT)	CONTROL VALVE	BASIS OF DESIGN STERLING			
FTR	0.70	7.0	H	I	-	-	V-5	3/4	50	1	JVC-611

SIZE ELEMENT TO MATCH HEAT OUTPUT INDICATED ON DRAWING.
ENCLOSURE SHALL BE RUN WALL-TO-WALL EXCEPT AS OTHERWISE NOTED.

LOUVER PERFORMANCE SCHEDULE											
TAG	AIR FLOW (CFM)	HP LOSS (IN. WG)	AIR VEL. (FPM)	SIZE (INCHES) (LxH)	FREE AREA (SQ. FT)	DRAINABLE (Y/N)	BLADE ANGLE (DEG)	FRAME DEPTH	SERVICE	MODEL	BLANK-OFF PANEL
L1	2100	.05	-	30"x36"	3.1	Y	35'	6"	EF 1 INTAKE	ELF6370CX	N
L2	2100	.05	-	30"x36"	3.1	Y	35'	6"	EF 2 INTAKE	ELF6370CX	N

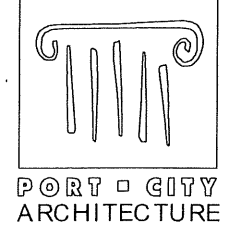
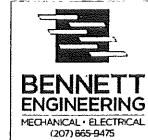

65 NEWBURY STREET
PORTLAND, ME 04101
207.761.9000
fax: 207.761.2010
info@portcityarch.com

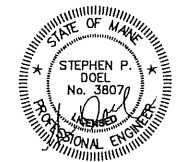

FOR CONSTRUCTION

CONSULTANTS:
Structural Integrity Consulting Engineers Inc.
77 Oak Street
Portland, Maine 04101
(207) 774-4614
contact: Aaron C. Jones, P.E.
aaron@structuralintegrity.com

Bennett Engineering
7 Bennett Road
Freeport, Maine 04037
(207) 865-9475
contact: Will Bennett, P.E.
will@bennettengineering.net

Portland Pump Company
9 Border Road
Scarborough, Maine 04070
(207) 883-4317
contact: Charlie Wilson
charlie@portlandpump.com

Enterprise Rent-a-Car
1128 Westbrook Street
Portland, Maine

REVISIONS		
#	DATE	DESCRIPTION
1	9-1-11	BID SET
2	9-9-11	FOR CONSTRUCTION

Date Issued: SEPTEMBER 9, 2011

Project Number: 11101

Drawing Scale:

SHEET NAME:

HVAC Plan and Schedules

Drawn By:

SP Doel

Checked By:

SP Doel

