

DISPLAY THIS CARD ON PRINCIPAL FRONTAGE OF WORK CITY OF PORTLAND

Please Read Application And Notes, If Any, Attached

BUILDING & INSPECTION

PERMIT

Permit Number: 040358

PERMIT ISSUED
APR 22 2004
CITY OF PORTLAND

This is to certify that Northeast Airmotive Inc/Burns Signs

has permission to Refacing 30 sq. Ft. Sign. 225 S. Main St. X 150'

AT 987 Westbrook St 204 A001001

provided that the person or persons, firm or corporation accepting this permit shall comply with all of the provisions of the Statutes of Maine and of the ordinances of the City of Portland regulating the construction, maintenance and use of buildings and structures, and of the application on file in this department.

Apply to Public Works for street line and grade if nature of work requires such information.

Notification of inspection must be given and written permission procured before this building or part thereof is altered or closed-in.
HEAVY NOTICE IS REQUIRED.

A certificate of occupancy must be procured by owner before this building or part thereof is occupied.

OTHER REQUIRED APPROVALS

Fire Dept. _____

Health Dept. _____

Appeal Board _____

Other _____
Department Name

[Handwritten Signature]
Director, Building & Inspection Services

PENALTY FOR REMOVING THIS CARD

City of Portland, Maine - Building or Use Permit Application

389 Congress Street, 04101 Tel: (207) 874-8703, Fax: (207) 874-8716

Permit No: 04-0358	Issue Date: APR 2 2004	CBL: 204 A001001
-----------------------	---------------------------	---------------------

Location of Construction: 987 Westbrook St	Owner Name: Northeast Airmotive Inc	Owner Address: 1011 Westbrook St	Phone: 207-774-6318
Business Name: n/a	Contractor Name: Burr Signs	Contractor Address: 10 Buttonwood St. So. Portland	Phone: 2077991183
Lessee/Buyer's Name n/a	Phone:	Permit Type: Signs - Permanent	Zone: AB

Past Use: Portland Jetport / Airport Storage	Proposed Use: Airport Storage / Refacing 30 sq. Ft. Sign <i>New 20" x 150"</i>	Permit Fee: \$90.00	Cost of Work: \$0.00	CEO District: 3
Proposed Project Description: Refacing 30 sq. Ft. Sign. <i>New 20" x 150"</i>		FIRE DEPT: <input type="checkbox"/> Approved <input checked="" type="checkbox"/> Denied <i>N/A</i>	INSPECTION: Use Group: <i>U</i> Type: <i>Sign</i> <i>BOCA 1999</i>	
		Signature: <i>[Signature]</i>	Signature: <i>[Signature]</i>	

PEDESTRIAN ACTIVITIES DISTRICT (P.A.D.)

Action: Approved Approved w/Conditions Denied

Signature: _____ Date: _____

Permit Taken By: gg	Date Applied For: 04/06/2004	Zoning Approval	
------------------------	---------------------------------	------------------------	--

<p>1. This permit application does not preclude the Applicant(s) from meeting applicable State and Federal Rules.</p> <p>2. Building permits do not include plumbing, septic or electrical work.</p> <p>3. Building permits are void if work is not started within six (6) months of the date of issuance. False information may invalidate a building permit and stop all work..</p>	<p>Special Zone or Reviews</p> <p><input type="checkbox"/> Shoreland</p> <p><input type="checkbox"/> Wetland</p> <p><input type="checkbox"/> Flood Zone</p> <p><input type="checkbox"/> Subdivision</p> <p><input type="checkbox"/> Site Plan</p> <p>Maj <input type="checkbox"/> Minor <input type="checkbox"/> MM <input type="checkbox"/></p> <p><i>OK</i> Date: <i>4/20/04</i></p>	<p>Zoning Appeal</p> <p><input type="checkbox"/> Variance</p> <p><input type="checkbox"/> Miscellaneous</p> <p><input type="checkbox"/> Conditional Use</p> <p><input type="checkbox"/> Interpretation</p> <p><input type="checkbox"/> Approved</p> <p><input type="checkbox"/> Denied</p> <p>Date: _____</p>	<p>Historic Preservation</p> <p><input checked="" type="checkbox"/> Not in District or Landmark</p> <p><input type="checkbox"/> Does Not Require Review</p> <p><input type="checkbox"/> Requires Review</p> <p><input type="checkbox"/> Approved</p> <p><input type="checkbox"/> Approved w/Conditions</p> <p><input type="checkbox"/> Denied</p> <p>Date: _____</p>
---	--	---	--

CERTIFICATION

I hereby certify that I am the owner of record of the named property, or that the proposed work is authorized by the owner of record and that I have been authorized by the owner to make this application as his authorized agent and I agree to conform to all applicable laws of this jurisdiction. In addition, if a permit for work described in the application is issued, I certify that the code official's authorized representative shall have the authority to enter all areas covered by such permit at any reasonable hour to enforce the provision of the code(s) applicable to such permit.

SIGNATURE OF APPLICANT	ADDRESS	DATE	PHONE
RESPONSIBLE PERSON IN CHARGE OF WORK, TITLE		DATE	PHONE

City of Portland, Maine - Building or Use Permit

389 Congress Street, 04101 Tel: (207) 874-8703, Fax: (207) 874-8716

Permit No: 04-0358	Date Applied For: 04/06/2004	CBL: 204 A001001
------------------------------	--	----------------------------

Location of Construction: 987 Westbrook St	Owner Name: Northeast Airmotive Inc	Owner Address: 1011 Westbrook St	Phone: 207-774-6318
Business Name: n/a	Contractor Name: Burr Signs	Contractor Address: 10 Buttonwood St. So. Portland	Phone: (207) 799-1183
Lessee/Buyer's Name: n/a	Phone:	Permit Type: Signs - Permanent	

Proposed Use: Airport Storage / Refacing 30 sq. Ft. Sign and adding new 20"x150"	Proposed Project Description: Refacing 30 sq. Ft. Sign. And adding new 20"x150"
--	---

Dept: Zoning	Status: Approved	Reviewer: Marge Schmuckal	Approval Date: 04/20/2004
Note:			Ok to Issue: <input checked="" type="checkbox"/>
Dept: Building	Status: Approved with Conditions	Reviewer: Tammy Munson	Approval Date: 04/21/2004
Note:			Ok to Issue: <input checked="" type="checkbox"/>
1) Signage Installation to comply with Chapter 31 BOCA 1999			



Sign Permit Application

If you or the property owner owes real estate or personal property taxes or user charges on any property within the City, payment arrangements must be made before permits of any kind are accepted.

Location/Address of construction: 1021 WESTBROOK ST. Zone: _____

Total square footage of proposed structure: _____ Square footage of lot: _____
Lot frontage: _____ Tenant frontage: _____

Tax Assessor's Chart, Block & Lot
Chart# 204 Block# A Lot# -001-001

Owner: NORTHEAST AIRMOTIVE INC. Telephone: 207-774-6318

Lessee/buyer's name (If applicable)

Current use: AIRCRAFT STORAGE
Proposed use: SAME

Total s.f. of signage 30
\$2.00 per s.f. \$ 60., plus
30000 base fee
Fee: \$ 90.00
Awning-without signage:
\$30.00 for first \$1,000
plus \$9.00 each addict.
\$1,000
Fee: \$ _____

Applicant name, address & telephone:
NORTHEAST AIRMOTIVE, INC.
1011 WESTBROOK ST.
PORTLAND, MAINE 04102

If vacant, prior use: _____
How long has it been vacant? _____
Project description: _____
Number of tenants in lot? _____

Freestanding sign? ___ Yes ___ No
More than one sign? ___ Yes ___ No
Sign Attached to Building? Yes ___ No

Dimensions _____ Height _____
Dimensions _____ Height _____
Dimensions 150 INCHES LONG Height 20 INCHES

Awning ___ Yes ___ No Is awning backlit? ___ Yes ___ No Height off sidewalk? _____

Awning Height: _____ Length: _____ Depth: _____

Is there any message, trademark or symbol on it? Yes ___ No If Yes, total s.f. of panels/graphics: _____

Please describe: SEE ATTACHED DRAWING

List ALL existing signage and their dimensions:

ON FILE

refueling sign

cell # 939-3924

Contractor's name, address & telephone: EXXON / BURR SIGNS - RANDY BURR 799-1183

Who should we contact when the permit is ready: STEPHEN M. WALKER

Mailing address: 1011 WESTBROOK ST., PORTLAND, MAINE Phone: 774-6318 AA call

Once your permit is approved, we will notify you to come in and pick up your permit and review the requirements with our plan reviewer. Beginning work prior to receiving your permit will result in a violation fee of \$50.00. X 122

Please submit all of the information outlined in the Signage Application Checklist including a building sketch showing exactly where existing is and proposed signage will be located. Please include sketches/pictures of proposed signage. Failure to do so will result in the automatic denial of your permit.

At the discretion of the Planning and Development Department, additional information may be required prior to permit approval. For further information stop by the Building Inspections office, room 315 City Hall or call 874-8703.

I hereby certify that I am the Owner of record of the named property, or that the owner of record authorizes the proposed work and that I have been authorized by the owner to make this application as his/her authorized agent. I agree to conform to all applicable laws of this jurisdiction. In addition, if a permit for work described in this application is issued, I certify that the Code Official's authorized representative shall have the authority to enter all areas covered by this permit at any reasonable hour to enforce the provisions of the codes applicable to this permit.

Signature of applicant:

Stephen M. Walker

Date: 3-30-04

This is not a Permit; you may not commence any work until the Permit is issued.

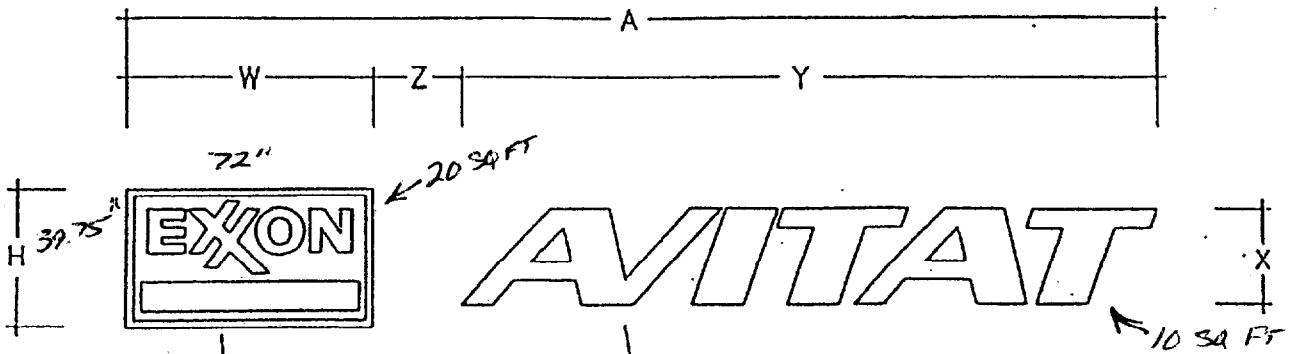

Internally Illuminated
Single Sided Standard
Exxon I.D. Sign

Internally Illuminated
Single Sided Avitat
Logo Sign, Face Color
Exxon Blue or Exxon
White to Contrast
with Building Color

$39.75 \times 72 = 2862 \text{ sq in}$
 $2862 \text{ sq in} \div 144 = 19.875 \text{ sq ft}$

$20 \times 150 = 3000 \text{ sq in}$
 $3000 \text{ sq in} \div 144 = 20.83 \text{ sq ft}$

All Dimensions in Inches Except Item A (Length)

Standard Exxon I.D. Sign Nominal Sq. Ft.	W.	H	X	Y	Z	A
10	50.00	28.50	20.00	150.0	18.00	18'-2"
20	72.50	39.70	27.00	203.0	26.00	25'-1 1/2"
30	88.00	48.44	33.00	248.0	31.50	30'-7 1/2"
40	97.50	53.50	36.00	271.0	36.00	33'-8 1/2"
70	135.00	73.75	50.00	376.0	50.00	46'-7"

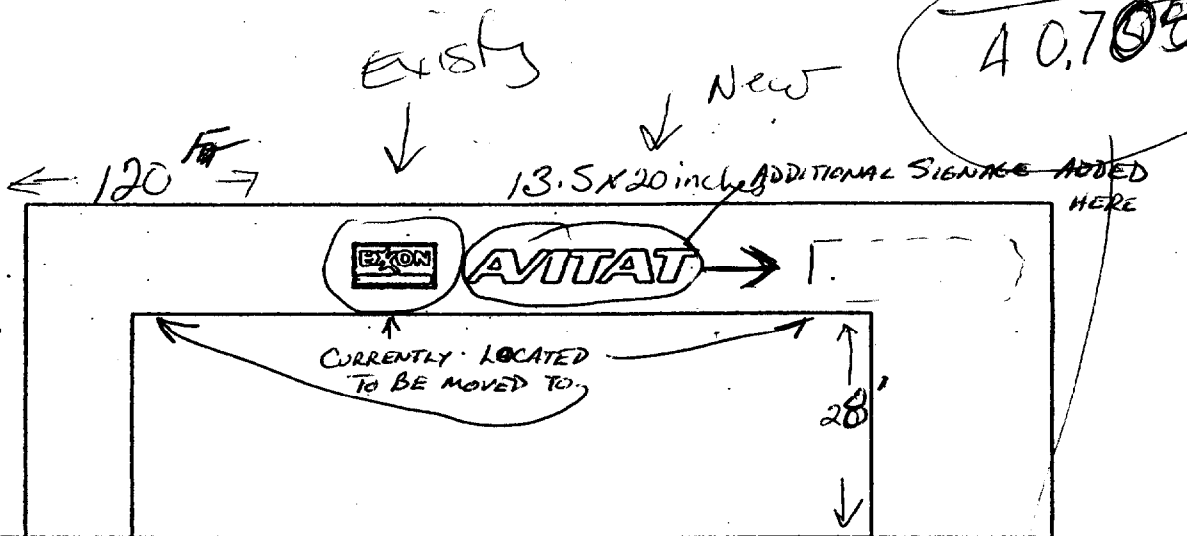

$19.875 + 40.708 = 60.583 \text{ sq ft}$

Typical Installation

$120 \times 1.5 = 180 \text{ sq ft}$

AVITAT

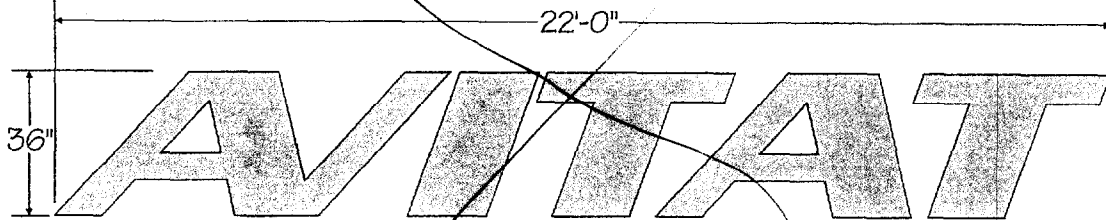

~~3 x 22 = 66 ft~~
 20" x 150" per other sheet

REMOTE TRANSFORMER MOUNTING DETAIL (EXTERIOR)

- | | |
|--|--|
| A. .050" ALUMINUM 5" RETURNS TO BE PAINTED PMS #300 BLUE | I. 3/8" RIV NUTS |
| B. 1" BLUE JEWELITE TRIM | J. 1/4" WEEP HOLES AS REQUIRED |
| C. .063" ALUMINUM BACKS - INSIDES TO BE PAINTED WHITE | K. SILICONE BEAD AROUND THE INSIDE OF RETURN AND BACK TO SEAL FROM WATER LEAKAGE |
| D. STANDARD TRANSFORMER IN A WEATHERPROOF SHEET METAL BOX | L. 1/4" LAG BOLTS OR 3/8" THREADED RODS WITH 2" x 4" WOOD BLOCKING AS REQ'D |
| E. #2051 BLUE .125" LEXAN FACES | M. 1/2" SEALTITE CONDUIT RUNNING TO SECONDARY CONNECTION |
| F. 15MM WHITE NEON | * NOTE: GENERAL CONTRACTOR TO HAVE PRIMARY CONNECTION HOOKED UP |
| G. TURNBACK WITH ELECTROBIT RUBBER BOOT; GTO WIRE WITH STRAIN RELIEF | N. HOV BOX FOR CONNECTION TO NEXT LETTER (SEE NOTE) |
| H. NEON TUBE SUPPORTS AS REQUIRED | |

NOTE: HOV BOXES TO BE IN WEATHER PROOF ENCLOSURES WHEN MOUNTED IN DAMP LOCATIONS. ALL TRANSFORMER BOXES TO HAVE TWO (2) WEEP HOLES WHEN MOUNTED IN A DAMP LOCATION.

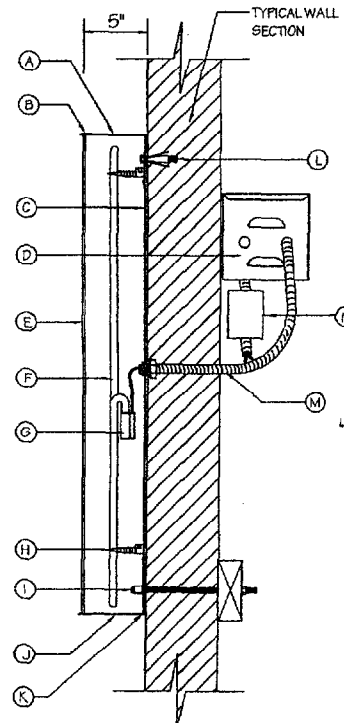

**SIDE SECTION VIEW
(NTS)**



"Paul Bradbury"
<PHB@portlandmaine.gov>

03/30/04 02:27 PM

To: SteveW@NortheastAirmotive.com

cc: MarkG@NortheastAirmotive.com, CLA@portlandmaine.gov,
JLS@portlandmaine.gov

Subject: Re: New Sign

Steve,

Thank you for submitting your request to add a sign to the east elevation of the Northeast Air Main GA Hangar. I have reviewed the installation and take no exceptions. This is an approval from the Jetport only, you must still file for a permit from the City of Portland Building Inspections Department. The Building Inspections office is located in City Hall room 315 and may be reached at 874-8703. Permit applications are available on the web at: www.portlandmaine.gov/planning/buildinginspect.htm

Best Regards,

Paul H. Bradbury, P.E.
Facilities Manager
Portland Int'l Jetport
1001 Westbrook St
Portland, ME 04102

207-756-8029

>>> <SteveW@NortheastAirmotive.com> 03/29 12:03 PM >>>

Paul,

Per our conversation earlier, I would like to obtain permission from the Jetport to add additional signage, per the drawing I gave you, to the East Face of our Main GA Hangar.

The sign will be approximately 10 square feet and spell out AVITAT, designating Northeast Air as an Elite Exxon FBO.

Any assistance you can render me, would be greatly appreciated.

Thanks!
Steve