

NOTE:

- BOARDS CONSTRUCTED OF 4" STEEL
- FACING & KICK PLATE ARE 1/2" POLY BOARD SHEETS

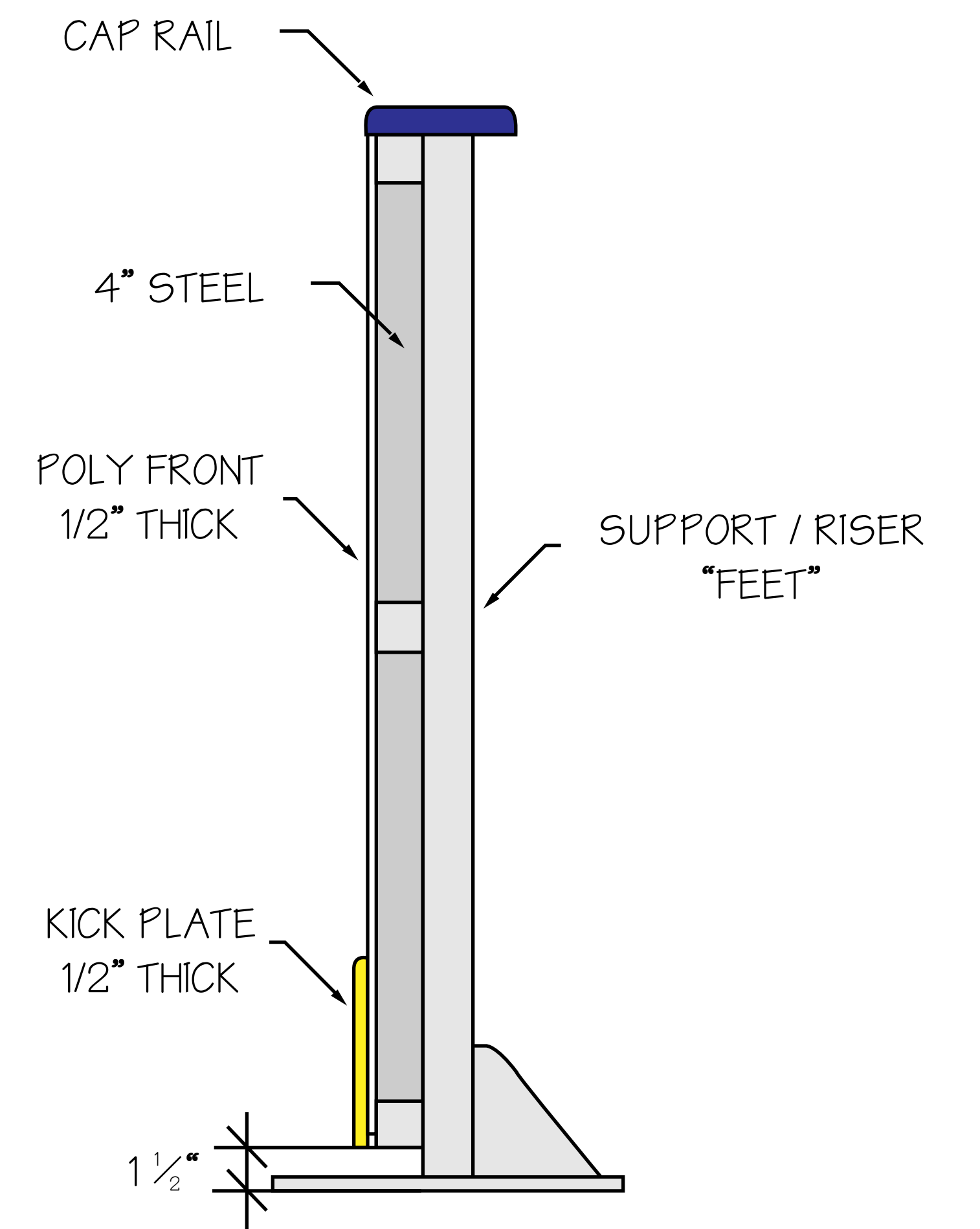

DASHERBOARDS

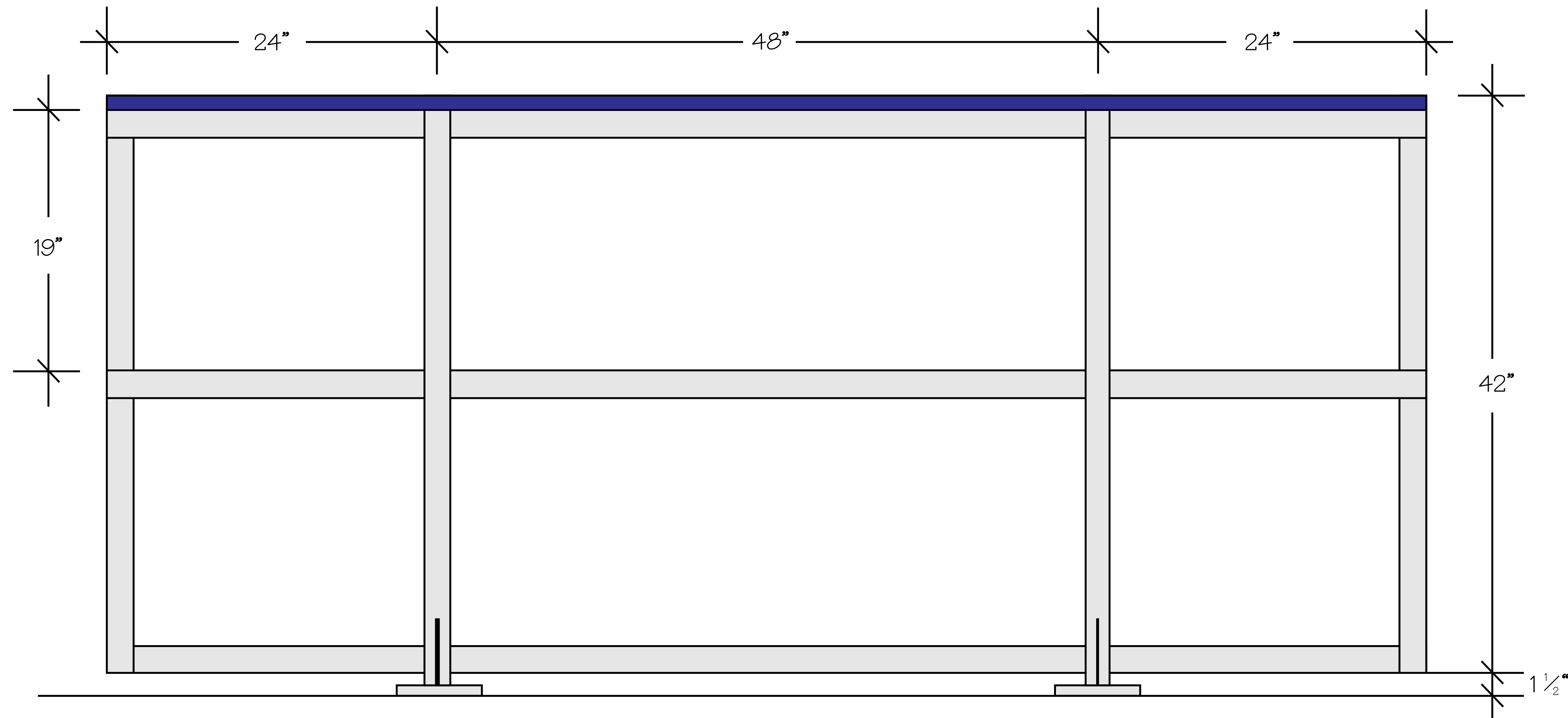

THOMPSON'S POINT

MM/DD/YY

/ /

REVISIONS

003