

EXAMPLE OF LIGHTING

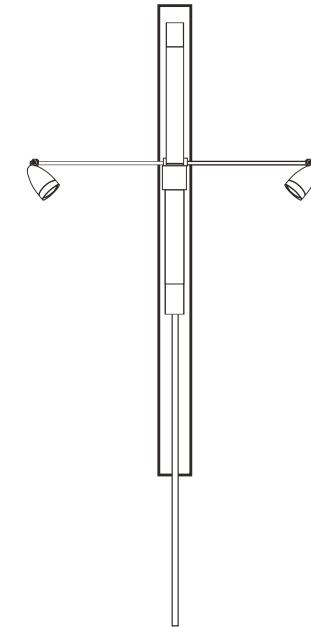

PLEASE NOTE:
 THIS IS A PROGRESS PRINT - FIELD MEASUREMENTS MAY OR MAY NOT NEED TO BE VERIFIED.
 THIS DESIGN IS THE EXCLUSIVE PROPERTY OF BAILEY SIGN INCORPORATED AND ALL RIGHTS TO ITS USE OR REPRODUCTION ARE RESERVED.
 THE ACCURACY OF THIS COLOR RENDERING IS LIMITED BY MEDIA AND OUTPUT DEVICES AND IS INTENDED FOR REPRESENTATIONAL USE ONLY. ACTUAL MANUFACTURING/GRAPHIC COLORS ALSO VARY DEPENDING ON PROCESSES & MATERIALS USED. 100% COLOR MATCHES OF SUBMITTED SPECIFICATIONS CAN NOT BE GUARANTEED.
 IF AN ELECTRIC SIGN, THEN INSTALLATION MUST BE ACCOMPLISHED IN TOTAL COMPLIANCE WITH ARTICLE 600 OF THE NATIONAL ELECTRIC CODE, THE REQUIREMENTS OF UNDERWRITERS LABORATORY, CANADIAN STANDARDS ASSOCIATION AND/OR ANY APPLICABLE LOCAL CODES. THIS INCLUDES PROPER GROUNDING AND BONDING OF THE SIGN.
 ALL ELECTRICAL SIGNS REQUIRE ROUTINE MAINTENANCE.

TENANT SIGNAGE: CUSTOM METAL BRACKET & D.F. 33" X 48" WOODEN SIGN PANEL

WALNUT WOOD PANEL
 CUT METAL LETTERS PAINTED WHITE
 METAL LOGO SYMBOL - FINISH TO BE DETERMINED

CLIENT

 ACCEPTANCE SIGNATURE DATE

BAILEY SIGN SALES REPRESENTATIVE

 APPROVED DATE

www.baileysign.com
 9 Thomas Drive
 Col. Westbrook Executive Park
 Westbrook, ME 04092
 207-774-2843 / 1-800-539-SIGN
 Fax: 774-1193
 E-Mail: sales@baileysign.com
 © COPYRIGHT 2015

CUSTOMER / SIGN LOCATION
CELLAR DOOR
 THOMPSON POINT
 PORTLAND, MAINE

SALESPERSON:	DRAWN BY: DB
	W.C. #
3/4" = 1'	DATE 3/3/2016

REVISION #	DATE	NOTES	INITIALS

DRAWING #
07576
 SHEET ____ OF ____