

PRODUCT DATA

PD19HE-2

Series 19HE Pressurized Wet Base Boiler/Burner Unit

Smith

CAST IRON BOILERS

Smith Series 19HE cast iron, pressurized, wet base boiler/burner units are ideal for light commercial water or steam heating systems utilizing No. 2 fuel oil, natural gas, or combination gas/oil. Ten different sizes are available, ranging from three-section, 308 MBH I=B=R gross output units to twelve-section, 1750 MBH I=B=R gross output units.

STANDARD FEATURES

- Cast iron wet base sections tested for 80 psi water working pressure, 15 psi steam working pressure
- Insulated metal jacket
- Burner mounting plate with insulation blocks
- Front and rear flame observation ports
- Steel angle floor rails
- Ceramic fiber rope seal between sections
- Hi-temp hydronic port seals
- Flue brush
- Target walls (3-6 sections)
- Manual, reset, hi-limit control
- Operating control

ADDITIONAL FEATURES FOR WATER BOILER/BURNER UNITS

- A.S.M.E. relief valve, 40 psi
- Theraltimeter

ADDITIONAL FEATURES FOR STEAM BOILER/BURNER UNITS

- A.S.M.E. side outlet safety valve, 15 psi
- Gauge glass with gauge cocks and guards



I B R Ratings, Burner Capacities

Designed and tested to the A.S.M.E. boiler and pressure vessel code, section IV for maximum allowable working pressure, steam 15 PSIG, water 80 PSIG.

Boiler Number	Boiler Horsepower	Heating Surface (Sq. Ft.)	Furnace Volume (Cu. Ft.)	I=B=R Gross Output	Net I=B=R Rating ⁽¹⁾			I=B=R Burner Capacity		Draft Loss (in W.C.)	Overfire ⁽⁴⁾ Pressure (in W.C.)	Water Content (Gals.)		Water Working Weight (Lbs.)	
					Steam		Water	Oil GPH ⁽²⁾	Gas MBH ⁽³⁾			Steam	Water	Steam	Water
					(Sq. Ft.)	MBH	MBH								
†19HE-*-3	9	23.9	2.12	308	963	231	268	2.60	375	0.18	0.28	33.2	38.6	1673.6	1716.8
†19HE-*-4	12	35.8	3.50	421	1316	316	369	3.60	520	0.18	0.28	41.1	49.2	2057.8	2122.6
†19HE-*-5	17	47.7	4.88	587	1835	441	510	5.00	725	0.20	0.30	49.0	59.8	2442.0	2528.4
†19HE-*-6	22	59.7	6.27	762	2382	572	663	6.50	931	0.23	0.33	56.8	70.3	2825.4	2933.4
†19HE-*-7	27	71.6	7.65	924	2888	694	803	7.90	1137	0.26	0.36	64.7	80.9	3209.6	3339.2
†19HE-*-8	32	83.5	9.04	1087	3398	817	945	9.30	1342	0.29	0.39	72.6	91.5	3593.8	3745.0
†19HE-*-9	37	95.4	10.42	1262	3945	947	1087	10.80	1548	0.32	0.42	80.5	102.0	3978.0	4150.0
†19HE-*-10	42	107.4	11.81	1424	4504	1081	1238	12.20	1754	0.35	0.45	88.3	112.6	4361.4	4555.8
†19HE-*-11	46	119.3	13.20	1587	5071	1217	1380	13.60	1989	0.38	0.48	96.2	123.1	4745.6	4960.8
†19HE-*-12	51	131.2	14.58	1750	5633	1352	1522	15.00	2165	0.41	0.51	104.0	133.7	5129.0	5366.6

† No insert for oil. Insert prefix "G" for gas or "GO" for combination gas/oil.

* Insert "S" for steam, "W" for water.
Example: GO19HE-S-10 is a 10-section 19HE Series Boiler for steam using combination gas/oil burner.

(1) The net I=B=R Steam Ratings shown are based on a piping and pickup allowance of 1.333. The I=B=R Water Ratings shown are based on an allowance of 1.15.

(2) Based on light oil having a heat content of 140,000 BTU per gallon.

(3) Gas having a heat content of 1,000 BTU/cu. ft. at 0.6 specific gravity.

(4) Includes 0.10" W.C. pressure on upstream side of exit damper.

Series 19HE

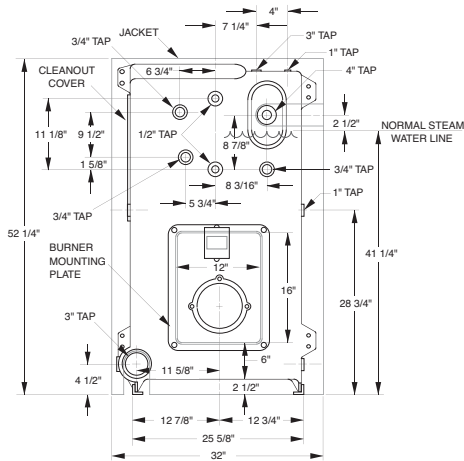

FRONT VIEW

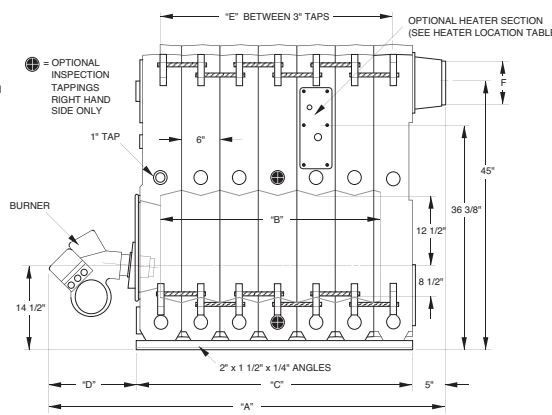

SIDE VIEW

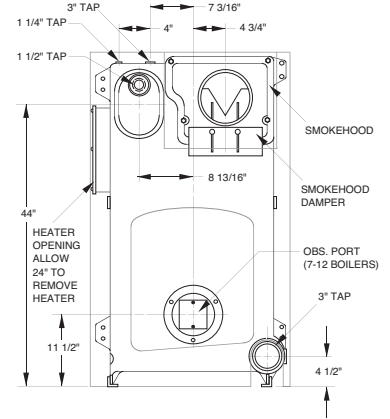

REAR VIEW

Dimensions (inches)

Boiler Number	Overall Length "A"				"B"	"C"	Burner Length "D"				"E" Distance Between Supply Tappings	"F" Flue Pipe Diameter
	Carlin	P/FJ	P/FC	Beckett			Carlin	P/FJ	P/FC	Beckett		
†19HE-*3	39	44	—	31	9	18	16	21	—	13	12	7
†19HE-*4	45	50	59	37	15	24	16	21	30	13	18	7
†19HE-*5	51	56	65	43	21	30	16	21	30	13	24	8
†19HE-*6	61	62	71	49	27	36	20	21	30	13	30	8
†19HE-*7	67	68	82	64	33	42	20	21	35	22	36	9
†19HE-*8	73	74	88	71	39	48	20	21	35	23	42	10
†19HE-*9	79	80	94	77	45	54	20	21	35	23	48	10
†19HE-*10	87	86	100	83	51	60	22	21	35	23	54	10
†19HE-*11	93	—	106	89	57	66	22	—	35	23	60	10+
†19HE-*12	99	—	112	99	63	72	22	—	35	27	66	10+

The manufacturer should be consulted before selecting a boiler for installations having unusual piping and pickup requirements, such as intermittent system operation, extensive piping, etc.

For forced hot water heating systems where the boiler and all the piping are within the area to be heated, the boiler may be selected on the basis of its Gross Output.

+ 11 and 12 section requires 12" diameter vent pipe. Transition collar provided by Smith.

NOTE: Dimensions are approximate. Should not be used to "rough-in" equipment.

Typical Steam Piping Diagram

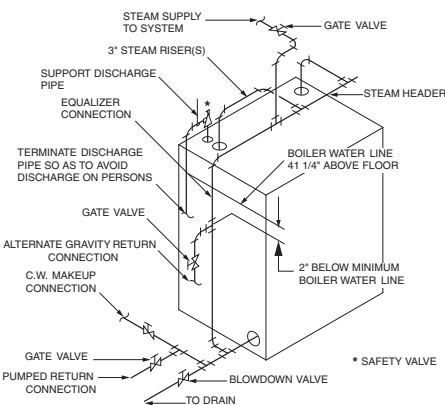

Boiler Size	No. of 3" Risers	Header	Equalizer
3 thru 5 Section	1	3"	1-1/2"
6 thru 10 Section	2	4"	2"
11 thru 12 Section	2	5"	2-1/2"

Typical Water Piping Diagram

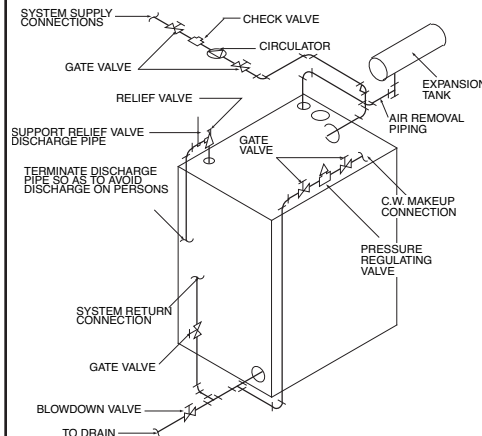

Boiler Size	GPM	Return Connection	Supply Connection
3	30	2"	2"
4	41	2"	2"
5	58	2-1/2"	2-1/2"
6	74	3"	3"
7	90	3"	3"
8	106	3"	3"
9	123	3"	3"
10	139	3"	3"
11	155	3"	4"
12	171	3"	4"

Based on 20°F temperature rise.

Smith
CAST IRON BOILERS

WESTCAST, INC.
260 NORTH ELM STREET WESTFIELD, MA 01085
TEL. (413) 562-9613 FAX (413) 562-3799

7555 TRANMERE DRIVE
MISSISSAUGA, ONTARIO L5S 1L4
TEL. (905) 672-2991 FAX (905) 672-2883