



Please fax this information to the Administrative Sales Assistant at the So. Portland Office at (207)-879-0540.

Building Owner Information Form

Job Name:	Project #:
------------------	-------------------

Electrical Contractor:

NFPA requires this information for proper documentation

****The contractor MUST provide all of the information with an asterisk below before ANY equipment can be released.***

If building owner contact is unknown provide contact name/tel. of GC and check box

Electrical Contractor Contact Name:
--

Estimated Date Equip. Needed:	*Estimated Finals Date:
--------------------------------------	--------------------------------

*Building Owner:

*Job Site Address:

*City:	State:	Zip:
---------------	---------------	-------------

*Contact Name: _____ Check here if GC

*Phone #:	Fax #:
------------------	---------------



Norris Inc.

PO Box 2551
2257 West Broadway
South Portland, ME 04106

1.800.370.3473
fax 207.879.0540

www.norrisinc.com

Thank you for your cooperation.

Please advise the building owners that if this system is equipped with a digital communicator, then they MUST also make monitoring arrangements prior to a certificate of occupancy. Norris Inc. will attempt to contact the building owners



STOP!

**THIS COPY IS FOR YOUR ELECTRICIAN
ON THE JOB-SITE**

PLEASE BE SURE THIS COPY IS FORWARDED

- 1) **A riser diagram is enclosed. DO NOT USE THE ENGINEER'S RISER SHOWN ON THE PLANS. If there is any information that you question, call us immediately.**
 - 2) **YOU MUST CALL AT LEAST FIVE DAYS IN ADVANCE TO SCHEDULE FINAL CONNECTION ASSISTANCE.**
 - 3) **All of your wires must be labeled and clear of any grounds, shorts or opens and must maintain polarity throughout. Meter out all circuits before calling for final connection assistance. If applicable verify End of Line resistors are in place.**
 - 4) **If using shielded cable, the drain wires must be connected and fully insulated (wrapped with tape) so that neither the shield or the drain wire touches the backbox.**
 - 5) **Unless special arrangements are made, we will make one final job-site visit. If a special visit is required for an elevator inspection or partial occupancy, then additional charges may apply if special arrangements were not made ahead. Call your customer service representative.**
 - 6) **If you have any defective or left-over parts DO NOT WRITE ON THEM OR THE BOXES. Save the original box, all mounting hardware and instructions. Returns that do not conform to this practice will not be accepted for credit.**
 - 7) **If the system is being monitored through a digital communicator, then please turn to page 2.**
-



Norris Inc.

PO Box 2551
2257 West Broadway
South Portland, ME 04106

1.800.370.3473
fax 207.879.0540

www.norrisinc.com

IMPORTANT INFORMATION FOR THE BUILDING OWNERS SPECIAL NOTE REGARDING ALARM MONITORING SERVICES

Included within your alarm system package is a digital communicator, which sends a coded message to a private 24-hour central station if your alarm system is activated. This is a code requirement for most fire alarm systems. As a service to our customer, we offer central station monitoring services from our local UL Listed central station at extremely competitive rates.

If the central station monitoring contract is purchased through Norris Inc. prior to our scheduled start-up; we will connect, program, and test the communicator at no additional charge.

Should the building owners decide to obtain monitoring services from another company, then the cost for programming and testing the communicator will be the sole responsibility of the firm they have contracted with. Furthermore, if programming changes are made to the system by persons other than Norris Inc. technicians, then the company performing the changes shall be solely liable for any personal injury or loss of life or damage to or loss of property arising out of the use of or inability to use the system and it shall result in a waiver of any system warranties.

We appreciate that you understand the delicate nature of this life safety and/or security system and realize that serious problems may arise when modifications to the system are made including very simple programming changes.

**Call Norris Inc. at 1-800-370-FIRE (3473) to make
arrangements for central station monitoring services.**



Norris Inc.

PO Box 2551
2257 West Broadway
South Portland, ME 04106

1.800.370.3473
fax 207.879.0540

www.norrisinc.com

SUBMITTAL PACKAGE

Project: Brick South at Thompson's Point

System: Fire Alarm System w/ Voice Evac

**Submitted By: Norris Inc.
2257 West Broadway
South Portland, Maine 04106
Telephone: (800) 370-3473**

Date: January 27th, 2017



Company Profile

"We are extremely proud to represent the highest quality manufacturers integrating life safety, alarm and communication systems throughout northern New England."

-- Bradford Norris, President --

Mission Statement

Provide quality engineered systems, exceptional service.

Goal

Learn...Continually Improve...Exceed Expectations

Founded in 1979 Norris Inc. has grown to become Northern New England's leading integrated system contracting and supply company. Norris Inc. is an innovated proactive organization with extensive experience in integration interdisciplinary building management systems. Our local and national affiliations assure that your project will be done properly regardless of size representing leading manufacturers our comprehensive products provide outstanding quality reliability and performance... surpassing customer application requirements and exceeding the stringent requirements of Underwriters Laboratories, National Fire Protection Association and other codes. We maintain an exceptional level of quality and provide the highest levels of customer service. Our knowledgeable technical support will insure the great service you deserve. Whether your needs involve industrial, commercial, institutional, or educational applications, you can trust that Norris Inc. has the complete resources it takes to provide the right solution right away.



This is to certify that

NORRIS, INC.

is an authorized Engineered Systems Distributor for NOTIFIER

During the years of 2015-2016



Signed for and on behalf of NOTIFIER

Vice President Global Sales



Norris Inc.

PO Box 2551
2257 West Broadway
South Portland, ME 04106

1.800.370.3473
fax 207.879.0540

www.norrisinc.com

LIMITED WARRANTY

Norris, Inc. warrants that the products of its manufacturers shall be free from defects in materials or workmanship as warranted by the manufacturer which is typically for a one (1) year period from the completed installation date, but not always. The completed installation date will be the date when the end-user was able to begin using or started using the product(s) or the system, whether partially or in its entirety. For projects that have a specification or bid instructions to follow which contains specific warranty requirements, Norris Inc. will always honor the warranty terms exactly as specified in the project's specifications or bid documents, which may be more or less in coverage and duration than the manufacturer's warranty. In performing hundreds of projects per year with thousands of different products it is impossible for Norris, Inc. to track the terms and details of specified or individual product warranties. Therefore Norris, Inc. will request that the owner's representative provide these special warranty details when the warranty work is requested; otherwise a standard one year warranty on the equipment will be honored. The manufacturer's warranty is for equipment only and does not include any labor and/or shipping costs. All warranties provided by Norris, Inc. are limited with the same limitations included with the manufacturer's warranty which is included in the manuals of the products being provided.

The warranty will apply only if such goods have been properly installed, are subject to normal proper use and have not been modified in any manner whatsoever. Upon return of the defective product, Norris, Inc. will, at its sole discretion, either repair or replace, at no cost, such goods determined to have a defect in materials or workmanship. In cases of a warranty repair, Norris, Inc. will use its sole discretion to determine if a suitable replacement part can be provided on loan while the repairs are being performed.

All warranty work is performed during regular business hours. If emergency warranty work is required, the customer will pay the difference between the emergency service bill and our normal hourly charges.

Norris, Inc.'s limited warranty does not apply to those products that are damaged due to misuse, abuse, negligence, exposure to adverse environmental conditions, acts of God or have been modified in any manner whatsoever.

Norris, Inc.'s Standard terms and conditions are provided with our invoices. Those Terms and Conditions shall be provided upon request.

NORRIS, INC. SHALL NOT UNDER ANY CIRCUMSTANCES BE LIABLE FOR ANY INCIDENTAL OR CONSEQUENTIAL DAMAGES ARISING FROM LOSS OF LIFE &/OR PROPERTY OR OTHER DAMAGE OR LOSSES OWING TO THE FAILURE OF NORRIS INC. PRODUCTS BEYOND THE COST OF REPAIR OR REPLACEMENT OF ANY DEFECTIVE PRODUCTS.

NORRIS, INC. MAKES NO WARRANTY OF FITNESS OR MERCHANTABILITY AND NO OTHER WARRANTY, ORAL OR WRITTEN, EXPRESS OR IMPLIED AS ALLOWED TO THE FULLEST EXTENT OF THE LAW.



Norris Inc.

PO Box 2551
2257 West Broadway
South Portland, ME 04106

1.800.370.3473
fax 207.879.0540

www.norrisinc.com

OUR CONTINUOUS COMMITMENT TO OUR ENVIRONMENT

At Norris, Inc. we are proudly committed to continuous environmental improvement for a sustainable future and to develop strong partnerships within our community.

Our mission while running our operations is to do everything within our power to improve the environmental quality of our world and to work together to create a clean and safe place to live in and work in for future generations.

We will incorporate and promote green practices within our operations with policies to support it, a system of rewarding those that fully embrace it and then will regularly review our practices for continuous improvement.

We will establish policies, make investments in technologies and set the example in our own operations to include our ongoing commitment to go paperless and making it a requirement to Reuse, Reduce & Recycle, to turn off unneeded lights, to not allow our vehicles to idle, to encourage carpooling and to utilize practical energy efficient transportation.

We will always be 100% compliant with all applicable environmental laws and regulations and will report any violations.

We will remain committed to working locally and whenever possible to sell and use locally manufactured products.

We will insist that every purchase we make will include a review of its environmental impact with a very high priority to selecting the greenest products and services available.

We will remain committed to selling low energy products. This includes promoting wireless technologies, using existing wire infrastructures in our installations, promoting solar powered devices, using our Remote Services in lieu of on-site service calls and performing calculations to minimize power supply and battery needs.

We will educate our employees and customers to illustrate that green practices and purchases are almost always less costly in the long run.

We will support and give priority to organizations that show the strongest commitment to the environment.

We will actively encourage and promote the same responsible green practices that we utilize in the work place to our employees for use in their everyday personal lives.



Norris Inc.

PO Box 2551
2257 West Broadway
South Portland, ME 04106

1.800.370.3473
fax 207.879.0540

www.norrisinc.com

REMOTE INTERNET CONNECTIONS

As an added service to our customers and in order to facilitate the commissioning of the system(s) being provided within this submittal and then later provide warranty support Norris, Inc. may (at Norris, Inc.'s option) use internet connections to gain access to the system(s) being provided. Many methods can be used, but the most popular is utilizing software named LogMeln. This software or any other method used to connect to the customer's network will allow Norris, Inc.'s technicians the ability to get onto the programming and diagnostic levels of the system(s) being provided via the building owner's or tenant's data network and program, diagnose or make needed changes to the operation of the system(s). This will provide a better working atmosphere to perform programming from a controlled environment without the disruptions of a construction job-site and will allow fast and efficient troubleshooting and/or servicing if problems should occur later. Acceptance of this submittal by those approving it shall constitute an acceptance and approval to perform the work necessary to install and/or enable these network connections if Norris, Inc. chooses to do so. It is the sole responsibility of the submittal approvers to advise the building owners and/or tenants that Norris, Inc. has the ability to gain access to their network. At the specific request of those approving this submittal or the contractor that Norris, Inc. is working for or the building owners or tenants that own the network, Norris, Inc. can remove or disable the ability to connect to the building's network. However, leaving it in place will allow for quicker and more cost effective service when it is needed. Under absolutely no circumstances shall Norris, Inc., its principals, employees or heirs be held responsible for any losses incurred as a result of this network connection or the inability for the network connection to operate as expected.

Norris Inc

2257 West Broadway

South Portland, ME 04106

1-800-370-3473

DEBLOIS ELECTRIC INC.

PO BOX 7899

LEWISTON, ME 04240

Tel:207-783-6512 Fax:207-783-7428

325668SP

Equipment List

Brick South

Description

NOTIFIER-NFS-320, Addressable Fire Alarm Panel

R5-RJ31X, UL 8P8C RJ31X JACK

R5-804R8, SILVER SATIN 8' PLUG - PLUG

NOTIFIER-UDACT-2, Digital Communicator

NOTIFIER-NFC50/100, Voice Evac Panel

IM-12180, 12V 18AH Battery

NOTIFIER-NFC-RM, Remote Microphone, Black

NOTIFIER-NFC-BDA-25V, Amplifier

NOTIFIER-FDU-80, Remote Annunciator

NOTIFIER-NBG-12LX, Addressable Pull Station

NOTIFIER-FSP-851, Addressable Smoke Detector

NOTIFIER-FST-851, Addressable heat Detector

NOTIFIER-B210LP, Detector Base

NOTIFIER-DNR, Duct Detector Housing

NOTIFIER-FSP-851R, Duct Detector Head

NOTIFIER-RTS151, Remote Test Station

NOTIFIER-DST3, Sampling Tube

NOTIFIER-FRM-1, Addressable Relay

NOTIFIER-FMM-101, Addressable Mini Module

NOTIFIER-FCPS-24S8, Remote Power Supply

ADI-IM-1270, 12V 7AH Battery

NOTIFIER-P2R, Horn Strobe, Wall, Red

NOTIFIER-SR, Strobe, Wall, Red

NOTIFIER-SPSR, Speaker Strobe, Wall, Red

Space Age-SSU00690, Fire Alarm Records Cabinet

O6ELOCKFA, Breaker Lock Out Kit

Norris Inc**2257 West Broadway****South Portland, ME 04106****1-800-370-3473****DEBLOIS ELECTRIC INC.**

PO BOX 7899

LEWISTON, ME 04240

Tel:207-783-6512 Fax:207-783-7428

325668SP**Equipment List****Brick South****Description**

KNOX4431, Recess Knox Box, Black

AES, AES Radio Masterbox

AES-7788F, UL Fire 8 Zone

EK-TRG1640, 16.5VAC, 45VA Transformer

AES-13-0346, Cable Assembly; 18# RG-58 Used to connect RG-8 with N male to

SPAAGEELE-VS000091, AES Radio Disconnect Enclosure

AES-7230, Standard Coaxial Surge Protector, N female N female

SR-3025TM, Box Tamper Switch

NOTIFIER-FRM-1, Addressable Relay

NOTIFIER-FMM-101, Addressable Mini Module

NOTIFIER-R-20T, Multi volt relay, track mount

NFS-320

Intelligent Addressable Fire Alarm System



Intelligent Fire Alarm Control Panels

General

The NFS-320 intelligent Fire Alarm Control Panel is part of the ONYX® Series of Fire Alarm Controls from NOTIFIER.

In stand-alone or network configurations, ONYX Series products meet virtually every application requirement.

The NFS-320's modular design makes system planning easier. The panel can be configured with just a few devices for small building applications, or networked with many devices to protect a large campus or a high-rise office block. Simply add additional peripheral equipment to suit the application.

For installations using NFS-320C, an optional ACM Series annunciator can be mounted in the same cabinet (up to 48 zones/points, order separately; see DN-60085).

NOTE: Unless called out with a version-specific "R", "C" or "E" at the end of the part number, "NFS-320" refers to models NFS-320, NFS-320R, NFS-320C, and NFS-320E.



NFS-320

Features

- Certified for seismic applications when used with the appropriate seismic mounting kit.
 - Approved for Marine applications when used with listed compatible equipment. See DN-60688.
 - One isolated intelligent Signaling Line Circuit (SLC) Style 4, 6 or 7.
 - Up to 159 detectors (any mix of ion, photo, thermal, or multi-sensor) and 159 modules (Addressable pull stations, normally open contact devices, two-wire smoke detectors, notification, or relay). 318 devices maximum.
 - Standard 80-character display.
 - Network options:
 - High-speed network for up to 200 nodes (NFS2-3030, NFS2-640, NFS-320(C), NFS-320SYS, NCA-2, DVC-EM, ONYXWorks, NFS-3030, NFS-640, and NCA).
 - Standard network for up to 103 nodes (NFS2-3030, NFS2-640, NFS-320(C), NFS-320SYS, NCA-2, DVC-EM, ONYXWorks, NCS, NFS-3030, NFS-640, NCA, AFP-200, AFP-300/400, AFP-1010, and AM2020). Up to 54 nodes when DVC-EM is used in network paging.
 - 6.0 A power supply with four Class A/B built-in Notification Appliance Circuits (NAC). Selectable System Sensor, Wheelock, or Gentex strobe synchronization.
 - Built-in Alarm, Trouble, Security, and Supervisory relays.
 - VeriFire® Tools online or offline programming utility. Upload/Download, save, store, check, compare, and simulate panel databases. Upgrade panel firmware.
 - Autoprogramming and Walk Test reports.
 - Multiple central station communication options:
 - Standard UDACT
 - Internet
 - Internet/GSM
 - 80-character remote annunciators (up to 32).
 - EIA-485 annunciators, including custom graphics.
 - Printer interface (80-column and 40-column printers).
- History file with 800-event capacity in nonvolatile memory, plus separate 200-event alarm-only file.
 - Alarm Verification selection per point, with automatic counter.
 - Presignal/Positive Alarm Sequence (PAS).
 - Silence inhibit and Auto Silence timer options.
 - NAC coding functions:
 - March time.
 - Temporal.
 - California two-stage coding.
 - Canadian two-stage.
 - Strobe synchronization.
 - Field-programmable on panel or on PC, with VeriFire® Tools program check, compare, simulate.
 - Full QWERTY keypad.
 - Battery charger supports 18 – 200 AH batteries.
 - Non-alarm points for lower priority functions.
 - Remote ACK/Signal Silence/System Reset/Drill via monitor modules.
 - Automatic time control functions, with holiday exceptions.
 - Extensive, built-in transient protection.
 - Powerful Boolean logic equations.

FLASHSCAN® INTELLIGENT FEATURES

- Polls up to 318 devices in less than two seconds.
- Activates up to 159 outputs in less than five seconds.
- Multicolor LEDs blink device address during Walk Test.
- Fully digital, high-precision protocol (U.S. Patent 5,539,389).
- Manual sensitivity adjustment — up to nine levels.
- Pre-alarm ONYX intelligent sensing — up to nine levels.
- Day/Night automatic sensitivity adjustment.
- Sensitivity windows:
 - Ion — 0.5 to 2.5%/foot obscuration.

- **Photo** - 0.5 to 2.35%/foot obscuration.
- **Laser (VIEW®)** - 0.02 to 2.0%/foot obscuration.
- **Acclimate® Plus™** - 0.5 to 4.0%/foot obscuration.
- **IntelliQuad** - 1.0 to 4.0%/foot obscuration.
- **IntelliQuad™ PLUS** - 1.0 to 4.0%/foot obscuration
- Drift compensation (U.S. Patent 5,764,142).
- Degraded mode — in the unlikely event that the NFS-320's primary microprocessor fails, FlashScan detectors revert to degraded operation and can activate the control panel's NAC circuits and alarm relay. Each of the four built-in panel circuits includes a Disable/Enable switch for this feature.
- Multi-detector algorithm involves nearby detectors in alarm decision (U.S. Patent 5,627,515).
- Automatic detector sensitivity testing (NFPA-72 compliant).
- Maintenance alert (two levels).
- Self-optimizing pre-alarm.

FSL-751 VIEW (VERY INTELLIGENT EARLY WARNING)

SMOKE DETECTION TECHNOLOGY

- Advanced ONYX intelligent sensing algorithms differentiate between smoke and non-smoke signals (U.S. Patent 5,831,524).
- Addressable operation pinpoints the fire location.
- Early warning performance comparable to the best aspiration systems at a fraction of the lifetime cost.

FAPT-851 ACCLIMATE® PLUS™

LOW-PROFILE INTELLIGENT MULTI-SENSOR

- Detector automatically adjusts sensitivity levels without operator intervention or programming. Sensitivity increases with heat.
- Microprocessor-based technology; combination photo and thermal technology.
- Low-temperature warning signal at 40°F ± 5°F (4.44°C ± 2.77°C).

FSC-851 INTELLIQUAD

ADVANCED MULTI-CRITERIA DETECTOR

- Detects all four major elements of a fire (smoke, heat, CO, and flame).
- Automatic drift compensation of smoke sensor and CO cell.
- High nuisance-alarm immunity.

FSA-8000 INTELLIGENT FAAST DETECTOR

- Connects directly to the SLC loop of compatible ONYX series panels
- Provides five event thresholds that can be individually programmed with descriptive labels for control-by-event programming; uses five detector addresses.
- Uses patented particle separator and field-replaceable filter to remove contaminants.
- Advanced algorithms reject common nuisance conditions

FCO-851 INTELLIQUAD™ PLUS

ADVANCED MULTI-CRITERIA FIRE/CO DETECTOR

- Detects all four major elements of a fire.
- Separate signal for life-safety CO detection.

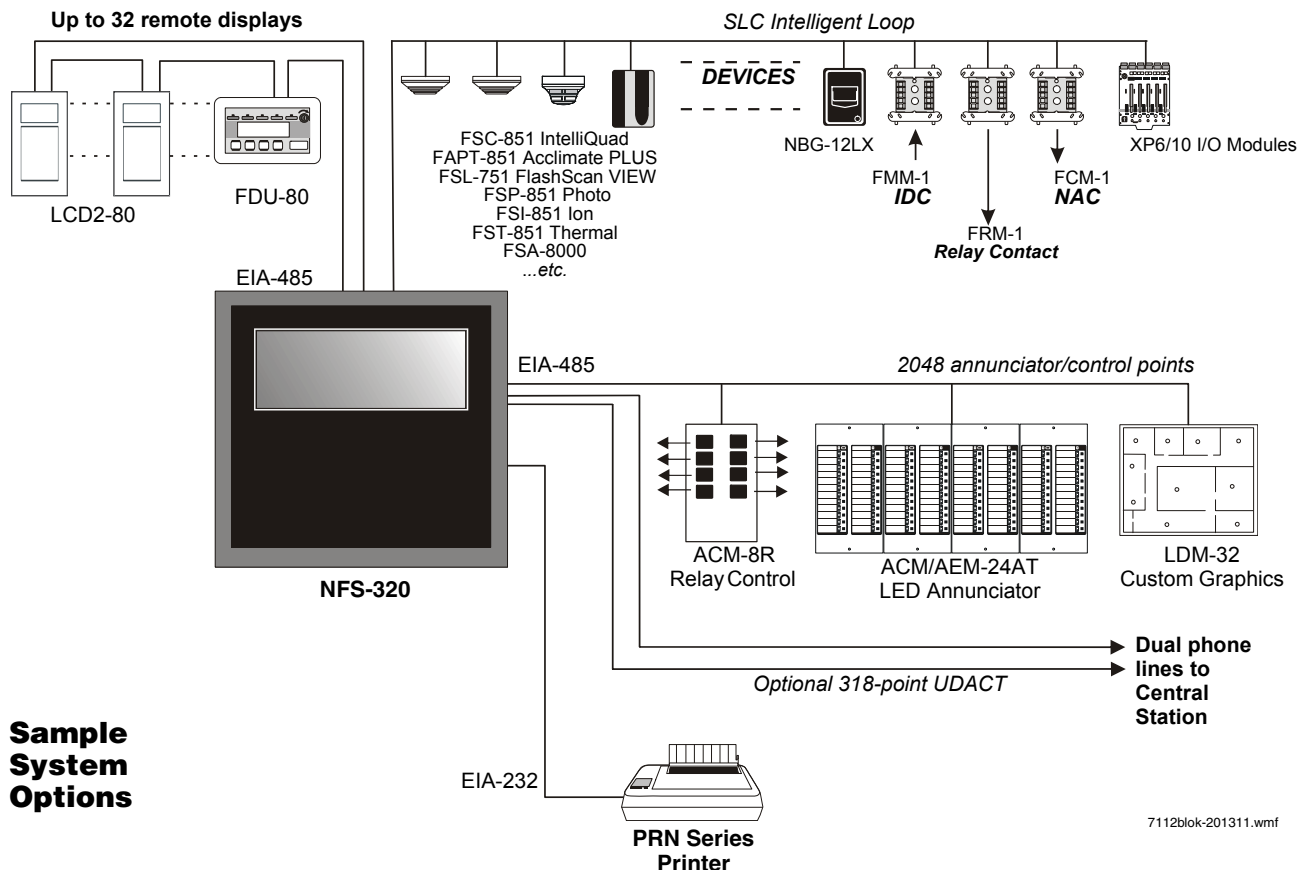

- Optional addressable sounder base for Temp-3 (fire) or Temp-4(CO) tone.
- Automatic drift compensation of smoke sensor and CO cell.
- High nuisance-alarm immunity.

RELEASING FEATURES

- Ten independent hazards.
- Sophisticated cross-zone (three options).
- Delay timer and Discharge timers (adjustable).
- Abort (four options).
- Low-pressure CO₂ listed.

VOICE FEATURES

- Integrates with FirstCommand Series. See DN-60772.
- Telephone applications require NFC-FFT.

HIGH-EFFICIENCY OFFLINE SWITCHING

3.0 A POWER SUPPLY (6.0 A IN ALARM)

- 120 VAC (NFS-320/NFS-320C); 240 VAC (NFS-320E).
- Displays battery current/voltage on panel (with display).

FlashScan, Exclusive World-Leading Detector Protocol

At the heart of the NFS-320 is a set of detection devices and device protocol — FlashScan (U.S. Patent 5,539,389). FlashScan is an all-digital protocol that gives superior precision and high noise immunity.

In addition to providing quick identification of an active input device, this protocol can also activate many output devices in a fraction of the time required by competitive protocols. This high speed also allows the NFS-320 to have the largest device per loop capacity in the industry — 318 points — yet every input and output device is sampled in less than two seconds. The microprocessor-based FlashScan detectors have bicolor LEDs that can be coded to provide diagnostic information, such as device address during Walk Test.

ONYX Intelligent Sensing

Intelligent sensing is a set of software algorithms that provides the NFS-320 with industry-leading smoke detection capability. These complex algorithms require many calculations on each reading of each detector, and are made possible by the high-speed microcomputer used by the NFS-320.

Drift Compensation and Smoothing: Drift compensation allows the detector to retain its original ability to detect actual smoke, and resist false alarms, even as dirt accumulates. It reduces maintenance requirements by allowing the system to automatically perform the periodic sensitivity measurements required by NFPA 72. Smoothing filters are also provided by software to remove transient noise signals, such as those caused by electrical interference.

Maintenance Warnings: When the drift compensation performed for a detector reaches a certain level, the performance of the detector may be compromised, and special warnings are given. There are three warning levels: (1) Low Chamber value; (2) Maintenance Alert, indicative of dust accumulation that is near but below the allowed limit; (3) Maintenance Urgent, indicative of dust accumulation above the allowed limit.

Sensitivity Adjust: Nine sensitivity levels are provided for alarm detection. These levels can be set manually, or can change automatically between day and night. Nine levels of

pre-alarm sensitivity can also be selected, based on predetermined levels of alarm. Pre-alarm operation can be latching or self-restoring, and can be used to activate special control functions.

Self-Optimizing Pre-Alarm: Each detector may be set for “Self-Optimizing” pre-alarm. In this special mode, the detector “learns” its normal environment, measuring the peak analog readings over a long period of time, and setting the pre-alarm level just above these normal peaks.

Cooperating Multi-Detector Sensing: A patented feature of ONYX intelligent sensing is the ability of a smoke sensor to consider readings from nearby sensors in making alarm or pre-alarm decisions. Without statistical sacrifice in the ability to resist false alarms, it allows a sensor to increase its sensitivity to actual smoke by a factor of almost two to one.

Field Programming Options

Autoprogram is a timesaving feature. The FACP “learns” what devices are physically connected and automatically loads them in the program with default values for all parameters. Requiring less than one minute to run, this routine allows the user to have almost immediate fire protection in a new installation, even if only a portion of the detectors are installed.

Keypad Program Edit (with KDM-R2) The NFS-320, like all NOTIFIER intelligent panels, has the exclusive feature of program creation and editing capability from the front panel keypad, while continuing to provide fire protection. The architecture of the NFS-320 software is such that each point entry carries its own program, including control-by-event links to other points. This allows the program to be entered with independent per-point segments, while the NFS-320 simultaneously monitors other (already installed) points for alarm conditions.

VeriFire® Tools is an offline programming and test utility that can greatly reduce installation programming time, and increase confidence in the site-specific software. It is Windows®-based and provides technologically advanced capabilities to aid the installer. The installer may create the entire program for the NFS-320 in the comfort of the office, test it, store a backup file, then bring it to the site and download from a laptop into the panel.

Placement of Equipment in Chassis and Cabinet

The following guidelines outline the NFS-320’s flexible system design.

Wiring: When designing the cabinet layout, consider separation of power-limited and non-power-limited wiring as discussed in the *NFS-320 Installation Manual*.

It is critical that all mounting holes of the NFS-320 are secured with a screw or standoff to ensure continuity of Earth Ground.

Networking: If networking two or more control panels, each unit requires a Network Communication Module or High-Speed Network Communication Module (HS-NCM) can support two nodes; see “Networking Options” on page 4). These modules can be installed in any option board position (see manual), and additional option boards can be mounted in front of them.

KDM-R2 Controls and Indicators

Program Keypad: QWERTY type (keyboard layout).

12 LED Indicators: Power; Fire Alarm; Pre-Alarm; Security; Supervisory; System Trouble; Signals Silenced; Points Disabled; Control Active; Abort; Pre-Discharge; Discharge.

Keypad Switch Controls: Acknowledge/Scroll Display; Signal Silence; Drill; System Reset; Lamp Test.

LCD Display: 80 characters (2 x 40) with long-life LED backlight.

Product Line Information

- “Configuration Guidelines” on page 4
- “Networking Options” on page 4
- “Auxiliary Power Supplies and Batteries” on page 4
- “Audio Options” on page 4
- “Compatible Devices, EIA-232 Ports” on page 4
- “Compatible Devices, EIA-485 Ports” on page 4
- “Compatible Intelligent Devices” on page 5
- “Enclosures, Chassis, and Dress Plates” on page 5
- “Other Options” on page 6

CONFIGURATION GUIDELINES

The NFS-320 system ships assembled; description and some options follow. See “Enclosures, Chassis, and Dress Plates” on page 5 for information about mounting peripherals.

NOTE: Stand-alone and network systems require a main display. On stand-alone systems, the panel’s keypad provides the required display. On network systems (two or more networked fire panel nodes), at least one NCA-2, NCS, or ONYXWorks annunciation device is required. (For NCA-2, see DN-7047.)

NFS-320: The standard, factory-assembled NFS-320 system includes the following components: one control panel mounted on chassis (120 V operation — ships with grounding cable, battery interconnect cables, and document kit); includes integral power supply mounted to the main circuit board; one primary display KDM-R2 keypad/display; and one cabinet for surface or semi-flush mounting. *Purchase batteries separately. One or two option boards may be mounted inside the NFS-320 cabinet; additional option boards can be used in remote cabinets. (Non-English versions also available. NFS-320-SP, NFS-320-PO.)*

NFS-320R: Same as NFS-320, but in red enclosure.

NFS-320C: Based on NFS-320 above. NFS-320C supports installation of an optional ACM-series annunciator in the same cabinet. UL- and ULC-listed. (Non-English version also available: NFS-320C-FR.) For NFS-320C, see DN-60085.

NFS-320CR: Same as NFS-320C but in a red enclosure. For NFS-320C, see DN-60085.

NFS-320E: Same as NFS-320, but with 240 V operation. (Non-English versions also available. NFS-320E-SP, NFS-320E-PO.)

TR-320: Trim ring for the NFS-320 cabinet.

NETWORKING OPTIONS

NCM-W, NCM-F: Standard Network Communications Modules. Wire and multi-mode fiber versions available. See DN-6861.

HS-NCM-W/MF/SF/WMF/WSF/MFSF: High-speed Network Communications Modules. Wire, single-mode fiber, multi-

mode fiber, and media conversion models are available. See DN-60454.

RPT-W, RPT-F, RPT-WF: Standard-network repeater board with wire connection (RPT-W), multi-mode fiber connection (RPT-F), or allowing a change in media type between wire and fiber (RPT-WF). Not used with high-speed networks. See DN-6971.

ONYXWorks: UL-listed graphics PC workstation, software, and computer hardware. See DN-7048 for specific part numbers.

NFN-GW-EM-3: NFN Gateway, embedded. See DN-60499.

NWS-3: NOTI•FIRE•NET™ Web Server. See DN-6928.

CAP-GW: Common Alerting Protocol Gateway. See DN-60576.

VESDA-HLI-GW: VESDAnet high-level interface gateway. See DN-60753.

LEDSIGN-GW: UL-listed sign gateway. Interfaces with classic and high-speed NOTI•FIRE•NET networks through the NFN Gateway. See DN-60679.

OAX2-24V: UL-listed LED sign, used with LEDSIGN-GW. See DN-60679.

AUXILIARY POWER SUPPLIES AND BATTERIES

ACPS-610: 6.0 A or 10.0 A addressable charging power supply. See DN-60244.

APS2-6R: Auxiliary Power Supply. Provides up to 6.0 amperes of power for peripheral devices. Includes battery input and transfer relay, and overcurrent protection. Mounts on two of four positions on a CHS-4L or CHS-4 chassis. See DN-5952.

FCPS-24S6/S8: Remote 6 A and 8 A power supplies with battery charger. See DN-6927.

BAT Series: Batteries. NFS-320 uses two 12 volt, 18 to 200 AH batteries. See DN-6933.

AUDIO OPTIONS

NFC-50/100: 25 watt, 25 VRMS, emergency Voice Evacuation Control Panel (VECP) with integral commercial microphone, digital message generator, and Class A or Class B speaker circuits. See DN-60772.

COMPATIBLE DEVICES, EIA-232 PORTS

PRN-6: 80-column printer. See DN-6956.

VS4095/5: Printer, 40-column, 24 V. Mounted in external backbox. See DN-3260.

DPI-232: Direct Panel Interface, specialized modem for extending serial data links to remotely located FACP’s and/or peripherals; mount on NFS-320 chassis. See DN-6870.

COMPATIBLE DEVICES, EIA-485 PORTS

ACM-24AT: ONYX Series ACS annunciator — up to 96 points of annunciation with Alarm or Active LED, Trouble LED, and switch per circuit. Active/Alarm LEDs can be programmed (by powered-up switch selection) by point to be red, green, or yellow; the Trouble LED is always yellow. See DN-6862.

AEM-24AT: Same LED and switch capabilities as ACM-24AT, expands the ACM-24AT to 48, 72, or 96 points. See DN-6862.

ACM-48A: ONYX Series ACS annunciator — up to 96 points of annunciation with Alarm or Active LED per circuit. Active/Alarm LEDs can be programmed (by powered-up switch

selection) in groups of 24 to be red, green, or yellow. Expandable to 96 points with one AEM-48A. *See DN-6862.*

AEM-48A: Same LED capabilities as ACM-48A, expands the ACM-48A to 96 points. *See DN-6862.*

ACM-8R: Remote Relay Module with eight Form-C contacts. Can be located up to 6,000 ft. (1828.8 m) from panel on four wires. *See DN-3558.*

FDU-80: Terminal mode. 80-character, backlit LCD display. Mounts up to 6,000 ft. (1828.8 m) from panel. Up to 32 per FACP. *See DN-6820.*

LCD2-80: Terminal and ACS mode. 80-character, backlit LCD display. Mounts up to 6,000 ft. (1828.8 m) from panel. Up to 32 per FACP. *See DN-60548.*

LDM: Lamp Driver Modules LDM-32, LDM-E32, and LDM-R32; remote custom driver modules. *See DN-0551.*

SCS: Smoke control stations SCS-8, SCE-8, with lamp drivers SCS-8L, SCE-8L; eight (expandable to 16) circuits (HVAC only). *See DN-4818.*

TM-4: Transmitter Module. Includes three reverse-polarity circuits and one municipal box circuit; mount on NFS-320 chassis or remotely. *See DN-6860.*

UDACT-2: Universal Digital Alarm Communicator Transmitter, 636 channel. *See DN-60686.*

UZY-256: Programmable Universal Zone Coder provides positive non-interfering successive zone coding. Microprocessor-controlled, field-programmable from IBM®-compatible PCs (requires optional programming kit). Mounts in **BB-UZY**. *See DN-3404.*

COMPATIBLE INTELLIGENT DEVICES

FSA-8000: Intelligent FFAST Fire Alarm Aspiration Sensing Technology®. Intelligent aspirating smoke detector. For Canadian applications, order FSA-8000A. *See DN-60792.*

FSB-200: Intelligent beam smoke detector. *See DN-6985.*

FSB-200S: Intelligent beam smoke detector with integral sensitivity test. *See DN-6985.*

FSC-851: FlashScan IntelliQuad Advanced Multi-Criteria Detector. *See DN-60412.*

FCO-851: FlashScan IntelliQuad PLUS Advanced Multi-Criteria Fire/CO Detector. *See DN-60689.*

FSI-851: Low-profile FlashScan ionization detector. *See DN-6934.*

FSP-851: Low-profile FlashScan photoelectric detector. *See DN-6935.*

FSP-851T: Low-profile FlashScan photoelectric detector with 135°F (57°C) thermal. *See DN-6935.*

FSP-851R: Remote-test capable photoelectric detector for use with DNR(W) duct detector housings. *See DN-6935.*

FST-851: FlashScan thermal detector 135°F (57°C). *See DN-6936.*

FST-851R: FlashScan thermal detector 135°F (57°C) with rate-of-rise. *See DN-6936.*

FST-851H: FlashScan 190°F (88°C) high-temperature thermal detector. *See DN-6936.*

FAPT-851: FlashScan Acclimate Plus low-profile multi-sensor detector. *See DN-6937.*

FSL-751: FlashScan VIEW laser photo detector. *See DN-6886.*

DNR: InnovairFlex low-flow non-relay duct-detector housing (order FSP-851R separately). Replaces FSD-751PL/FSD-751RPL. *See DN-60429.*

DNRW: Same as above with NEMA-4 rating, watertight. *See DN-60429.*

B224RB: Low-profile relay base. *See DN-60054.*

B224BI: Isolator base for low-profile detectors. *See DN-60054.*

B210LP: Low-profile base. Standard U.S. style. Replaces B710LP. *See DN-60054.*

B501: European-style, 4" (10.16 cm) base. *See DN-60054.*

B200S: Intelligent programmable sounder base, capable of producing a variety of tone patterns including ANSI Temporal 3. Compatible with synchronization protocol. *See DN-60054.*

B200SR: Sounder base, Temporal 3 or Continuous tone. *See DN-60054.*

FMM-1: FlashScan monitor module. *See DN-6720.*

FDM-1: FlashScan dual monitor module. *See DN-6720.*

FZM-1: FlashScan two-wire detector monitor module. *See DN-6720.*

FMM-101: FlashScan miniature monitor module. *See DN-6720.*

FCM-1: FlashScan control module. *See DN-6724.*

FCM-1-REL: FlashScan releasing control module. *See DN-60390.*

FRM-1: FlashScan relay module. *See DN-6724.*

FDRM-1: FlashScan dual monitor/dual relay module. *See DN-60709.*

NBG-12LX: Manual pull station, addressable. *See DN-6726.*

ISO-X: Isolator module. *See DN-2243.*

XP6-C: FlashScan six-circuit supervised control module. *See DN-6924.*

XP6-MA: FlashScan six-zone interface module; connects intelligent alarm system to two-wire conventional detection zone. *See DN-6925.*

XP6-R: FlashScan six-relay (Form-C) control module. *See DN-6926.*

XP10-M: FlashScan ten-input monitor module. *See DN-6923.*

SLC-IM: SLC integration module, for VESDAnet detectors. *See DN-60755.*

ENCLOSURES, CHASSIS, AND DRESS PLATES

CAB-BM Marine System: Protects equipment in shipboard and waterfront applications. Also order **BB-MB** for systems using 100 AH batteries. For a full list of required and optional equipment, see *DN-60688.*

BB-UZY: Backbox for housing the UZY-256. Required for NFS-320 applications. Black. For red, order BB-UZY-R.

NFS-LBB: Battery Box (required for batteries larger than 26 AH).

NFS-LBBR: Same as above, but red.

SEISKIT-320/B26: Seismic mounting kit. Required for seismic-certified applications with NFS-320 and BB-26. Includes battery bracket for two 26 AH batteries.

SEISKIT-BB25: Seismic mounting kit for the BB-25. Includes battery bracket for two 26 AH batteries.

SEISKIT-LBB: Seismic kit for the NFS-LBB. Includes battery bracket for two 55 AH batteries.

OTHER OPTIONS

411: Slave Digital Alarm Communicator. See DN-6619.

411UDAC: Digital Alarm Communicator. See DN-6746.

IPDACT-2/2UD, IPDACT Internet Monitoring Module: Connects to primary and secondary DACT telephone output ports for internet communications over customer-provided Ethernet connection. Requires compatible Teldat VisorALARM Central Station Receiver. Can use DHCP or static IP. See DN-60408.

IPSPLT: Y-adaptor option allow connection of both panel dialer outputs to one IPDACT-2/2UD cable input.

IPENC: External enclosure for IPDACT, includes IPBRKT mounting bracket; Red. For Black order **IPENC-B**.

IPGSM-4G: Internet and Digital Cellular Fire Alarm Communicator. Provides selectable configurable paths: cellular only, IP only, or IP primary with cellular backup. Connects to the primary and secondary ports of a DACT. See DH-60769.

NFS-320-RB: Replacement board with central processing unit (CPU). *NOTE: Keypad must be removed before shipping old unit out for repair.*

- NFS-320-RBE: Replacement CPU, Export.
- NFS-320-RB-PO: Replacement CPU, Portuguese.
- NFS-320-RB-POE: Replacement CPU, Export, Portuguese.
- NFS-320-RBC-FR: Replacement CPU, Canadian French.
- NFS-320-RB-SP: Replacement CPU, Spanish.
- NFS-320-RB-SPE: Replacement CPU, Export, Spanish.

NOTE: For other options including compatibility with retrofit equipment, refer to the panel's installation manual, the SLC manual, and the Device Compatibility Document.

System Specifications

SYSTEM CAPACITY

- Intelligent Signaling Line Circuits 1
- Intelligent detectors 159
- Addressable monitor/control modules 159
- Programmable internal hardware and output circuits 4
- Programmable software zones 99
- Special programming zones 14
- LCD annunciators per NFS-320/-320E 32
- ACS annunciators per NFS-320/-320E 32 addresses x 64 points

SPECIFICATIONS

- Primary input power
 - NFS-320: 120 VAC, 50/60 Hz, 5.0 A.
 - NFS-320E: 220/240 VAC, 50/60 Hz, 2.5 A.

- Current draw (standby/alarm):
 - NFS-320(E) board: 0.250 A. Add 0.035 A for each NAC in use.
 - KDM-R2 (Backlight on): 0.100 A.
- Total output 24 V power: 6.0 A in alarm.

NOTE: The power supply has a total of 6.0 A of available power. This is shared by all internal circuits. See Installation Manual for a complete current draw calculation sheet.

- Standard notification circuits (4): 1.5 A each.
- Resettable regulated 24V power: 1.25 A.
- Two non-resettable regulated 24V power outputs:
 - 1.25 A.
 - 0.50 A.
- Non-resettable 5V power: 0.15 A.
- Battery charger range: 18 AH – 200 AH. Use separate cabinet for batteries over 26 AH.
- Float rate: 27.6 V.

CABINET SPECIFICATIONS

NFS-320 cabinet dimensions:

- Backbox: 18.12 in. (46.025 cm) width; 18.12 in. (46.025 cm) height; 5.81 in. (14.76 cm) depth.
- Door: 18.187 in. (46.195 cm) width; 18.40 in. (46.736 cm) height; 0.75 in. (1.905 cm) depth.
- Trim ring: Molding width is 0.905 in. (2.299 cm).
- Shipping weight (without batteries): 36.15 lb. (16.4 kg).

TEMPERATURE AND HUMIDITY RANGES

This system meets NFPA requirements for operation at 0 – 49°C/32 – 120°F and at a relative humidity 93% ± 2% RH (noncondensing) at 32°C ± 2°C (90°F ± 3°F). However, the useful life of the system's standby batteries and the electronic components may be adversely affected by extreme temperature ranges and humidity. Therefore, it is recommended that this system and its peripherals be installed in an environment with a normal room temperature of 15 – 27°C/ 60 – 80°F.

AGENCY LISTINGS AND APPROVALS

The listings and approvals below apply to the basic NFS-320 control panel. In some cases, certain modules may not be listed by certain approval agencies, or listing may be in process. Consult factory for latest listing status.

- **UL Listed:** S635.
- **ULC Listed:** S635 (NFS-320C only, excludes IPDACT).
- **FM Approved.**
- **CSFM:** 7165-0028:0243.
- **MEA:** 128-07-E.
- **FDNY:** COA#6085, #6121.
- **City of Chicago.**

NOTE: For additional information on UL- and ULC-listed model NFS-320C, see DN-60085. For information on NFS-320SYS, see DN-60637.

Marine Applications: Marine approved systems must be configured using components itemized in this document. (See Main System Components, in "Product Line Information.") Specific connections and requirements for those components are described in the installation document,

PN 54756. When these requirements are followed, systems are approved by the following agencies:

- **US Coast Guard** 161.002/50/0, 161.002/55/0 (Standard 46 CFR and 161.002).
- **Lloyd's Register** 11/600013 (ENV 3 category).
- **American Bureau of Shipping** (ABS) Type Approval.

NOTE: For information on marine applications, see DN-60688.

STANDARDS

The NFS-320 complies with the following UL Standards and NFPA 72, International Building Code (IBC), and California Building Code (CBC) Fire Alarm Systems requirements:

- **UL 864** (Fire).
- **UL 1076** (Burglary).
- **UL 2572** (Mass Notification Systems).
- **LOCAL** (Automatic, Manual, Waterflow and Sprinkler Supervisory).
- **AUXILIARY** (Automatic, Manual and Waterflow) (requires TM-4).
- **REMOTE STATION** (Automatic, Manual, Waterflow and Sprinkler Supervisory) (requires TM-4).
- **PROPRIETARY** (Automatic, Manual, Waterflow and Sprinkler Supervisory). *Not applicable for FM.*
- **CENTRAL STATION** (Automatic, Manual, Waterflow and Sprinkler Supervisory) (requires DACT).
- **EMERGENCY VOICE/ALARM.**
- **OT, PSDN** (Other Technologies, Packet-switched Data Network).
- **IBC 2012, IBC 2009, IBC 2006, IBC 2003, IBC 2000** (Seismic).
- **CBC 2007** (Seismic).

NOTI•FIRE•NET™, **IntelliQuad™**, and **ONYXWorks™** are trademarks; and **Acclimate® Plus™**, **FirstCommand®**, **FlashScan®**, **NOTIFIER®**, **ONYX®**, **VeriFire®**, and **VIEW®** are registered trademarks of Honeywell International Inc. **Microsoft®** and **Windows®** are registered trademarks of Microsoft Corporation. **IBM®** is a registered trademark of IBM Corporation.
©2013 by Honeywell International Inc. All rights reserved. Unauthorized use of this document is strictly prohibited.



This document is not intended to be used for installation purposes.
We try to keep our product information up-to-date and accurate.
We cannot cover all specific applications or anticipate all requirements.
All specifications are subject to change without notice.

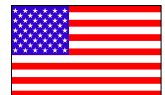

Made in the U.S. A.

For more information, contact Notifier. Phone: (203) 484-7161, FAX: (203) 484-7118.
www.notifier.com

FDU-80

80 Character Liquid Crystal Display

Annunciators

General

The FDU-80 is a compact, cost-effective, 80-character, backlit LCD remote Fire Annunciator for use with the NOTIFIER Fire-Warden-100-2, NFS2-640, and NFS-320 Fire Alarm Control Panels (FACPs). The FDU-80 mimics the display of the control panel and displays complete system point status information.

Up to 32 FDU-80s may be connected onto the EIA-485 terminal port of each FACP. The FDU-80 requires no programming, which saves time during system commissioning.

Features

- 80-character Liquid Crystal Display.
- Mimics all display information from the host panel.
- Control switches for System Acknowledge, Signal Silence, Drill and Reset with enable key.
- System status LEDs for Power, Alarm, Trouble, Supervisory and Alarm Silenced.
- No programming necessary — FDU-80 connects to the terminal port on the FACP.
- Displays device type identifiers, individual point alarm, trouble or supervisory, zone and custom alpha labels.
- Time-and-date display field.
- Aesthetically pleasing design.
- May be powered from the host FACP or by remote power supply (requires 24 VDC).
- Up to 32 FDU-80 annunciators per FACP.
- Plug-in terminal blocks for ease of installation and service.
- Can be remotely located up to 6,000 feet (1828.8 m) from the FACP.
- Local piezo sounder with alarm and trouble resound.
- Semi-flush mounts to 2.188" (5.556 cm) minimum deep, three-gang electrical box (NOTIFIER PN **10103**) or three-gangable electrical switchbox.
- Surface-mounts to NOTIFIER PN **SBB-3** surface backbox.

Operation

The FDU-80 annunciator provides the FACP with point annunciation with full display text on an 80-character LCD display. The FDU-80 also provides an array of LEDs to indicate system status, and includes control switches for remote control of critical system functions.

The FDU-80 provides the FACP with up to 32 remote serially connected annunciators. All field-wiring terminations on the FDU-80 use removable, compression-type terminal blocks for ease of wiring and circuit testing.

Communication between the FACP and the annunciators is accomplished over an EIA-485 serial interface, which greatly reduces wire and installation cost over traditional systems.

Installation

The FDU-80 can be semi-flush mounted to a 2.188" (5.556 cm) minimum deep, three-gang electrical box or three-gangable electrical switchboxes. Alternately, an SBB-3 surface backbox is available for surface-mount applications.



6820fdub.jpg

Ordering Information

FDU-80: 80 character, backlit, LCD Fire Annunciator with control switches for remote control of system functions, and key-switch lock.

FDU-80C: ULC-listed version; see DN-60573 for details.

10103: Three-gang electrical box, minimum 2.188" (5.556 cm) deep, for semi-flush mount applications.

SBB-3: Three-gang surface backbox for surface-mount applications.

Agency Listings And Approvals

These listings and approvals apply to the modules specified in this document. In some cases, certain modules or applications may not be listed by certain approval agencies, or listing may be in process. Consult factory for latest listing status.

- **UL Listed:** S635
- **MEA Listed:** 245-00-E
- **FDNY:** COA#6038
- **CSFM:** 7120-0028:209
- **FM Approved**

NOTE: For ULC-listed version, see DN-60573.

NOTIFIER® is a registered trademark of Honeywell International Inc.
©2010 by Honeywell International Inc. All rights reserved. Unauthorized use
of this document is strictly prohibited.



This document is not intended to be used for installation purposes.
We try to keep our product information up-to-date and accurate.
We cannot cover all specific applications or anticipate all requirements.
All specifications are subject to change without notice.



Made in the U.S. A.

For more information, contact Notifier. Phone: (203) 484-7161, FAX: (203) 484-7118.
www.notifier.com

UDACT-2

Universal Digital Alarm Communicator Transmitter



Annunciator Control System

General

The Universal Digital Alarm Communicator Transmitter (UDACT-2) is designed for use on Notifier Fire Alarm Control Panels and on the NCA-2 Network Control Annunciator. When used in conjunction with the NCA-2 network control annunciator, the UDACT-2 can report the status of all control panels on NOTI•FIRE•NET™. The UDACT-2 transmits system status to UL listed Central Station Receivers via the public switched telephone network. The UDACT-2 can be installed in the panel cabinet or remotely in a separate enclosure.

NOTE: The UDACT-2 can also be used with legacy panels. Please refer to the UDACT-2 manual for more information.

The UDACT-2 upload/download programming and firmware updates are accomplished with VeriFire Tools. Refer to the Programming Section for further details.

The UDACT-2 is capable of transmitting the status of software zones (Alarm and Trouble), System Trouble, Panel Off-Normal, Supervisory, Bell Trouble, Low Battery, and AC Fail. The UDACT-2 is capable of transmitting all of the zone and point status associated with each panel.

When the UDACT-2 is used with the NFS-3030, NFS2-3030, and NCA-2 it is capable of reporting up to 2,040 points. Reporting may be in the form of points or zones (refer to the UDACT-2 manual for specific reporting parameters). Points transmitted may be programmed for a variety of types, including fire, water-flow, supervisory, etc.

NOTE: Descriptions regarding point capacity, listed above, are for receivers which receive in Ademco Contact ID format. See chart on page 2 for compatible receivers.

Features

- Programmable with VeriFire Tools version 6.60 or higher, allowing the UDACT-2 programming to be uploaded/downloaded and saved.
- Maximum of 14 point trouble messages transmitted per hour.
- Dual phone lines with line voltage detect.
- Compact in size: 6.75" x 4.25" (17.145 x 10.795 cm).
- USB port for upload/download programming.
- Manual Test Report function.
- Manual Transmission Clear function.
- Mounts in a separate enclosure (ABS-8RB or UBS-1B/R).
- Communicates vital system status including:
 - Independent zone fire alarm.
 - Independent zone non-fire alarm.
 - Independent zone trouble.
 - Independent zone supervisory.
 - AC (mains) Power Loss (programmable).
 - Low Battery and Earth Fault.
 - System Off-Normal.
 - 12 or 24 hour test signal.
 - Abnormal Test Signal per new UL requirements.
 - EIA-485 Communication Bus Failure.
- Annunciation of UDACT-2 Troubles including: loss of phone lines, communication failure with either Central Station, total communications failure.
- Individual LEDs for: Power, EIA-485 Loss, Manual Test, Kiss-off, Comm Fail, Primary Line Seize, Secondary Line Seize and Modem Communications.

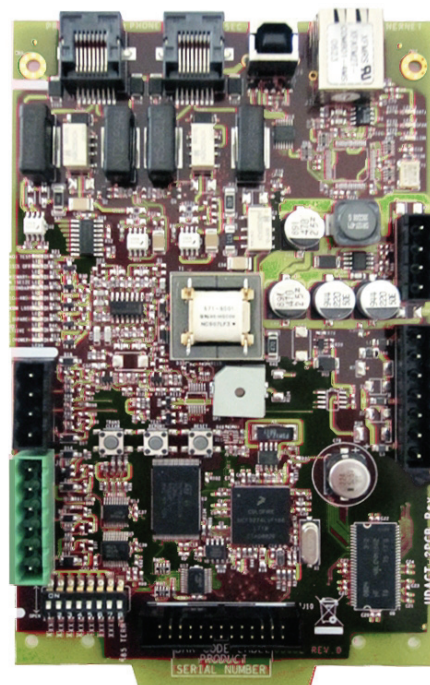

UDACT-2

- Open Collector relay driver for Total Communications Failure or UDACT-2 trouble.
- Real-time clock.
- Extensive transient protection.
- EIA-485 interface to host panel.

Programming

The UDACT-2 programming is created and downloaded using VeriFire Tools. This enables the unit to be programmed prior to installation, be easily modified, and saved either online or offline. A printed report with point or zone information can be generated from VeriFire Tools for an ONYX Series panel or network annunciator. The point report consists of the central station point address, ACS point, ACS point function, panel label, panel point, type code, custom and extended label, alarm verification, walktest participation, presignal, and PAS information. The zone report consists of a grid with the central station point address, ACS point address, source, ACS point function, custom label and panel label. This report may be sent to the Central Station for their records. VeriFire Tools also supports upgrading the UDACT-2 operating firmware.

Communication Formats

- Ademco Contact ID
- 4+2 Standard
- SIA

NOTE: Ademco Contact ID must be used for independent zone reporting.

Type Mode Feature

Ademco Contact ID format - only Use Type Mode to identify reports to Central Station as:

- Fire Alarm
- Supervisory
- Pull Station
- Heat Detector
- Waterflow
- Duct Detector
- Flame Sensor
- Smoke Zone
- Burglary
- 24 hour Non-Burglary
- High Temperature
- Low Temperature
- Low Water Pressure
- Low Water Level
- Pump Failure

Electrical Specifications

Standby current: 40 mA.

Current while communicating: 75 mA.

Maximum current while communicating and with open collector output activated: 100 mA.

Voltage: Regulated 24 volts. Range: 21.2 to 28.2 volts.

Agency Listings and Approvals

In some cases, certain modules may not be listed by certain approval agencies, or listing may be in process. Consult factory for latest listing status.

- UL/ULC Listed: S635
- FM Approved
- CSFM: 7165-0028:0243 (NFS2-640/320), 7165-0028:0224 (NFS2-3030)
- FDNY: COA#6085, COA#6098

Ordering Information

UDACT-2: Universal Digital Alarm Communicator Transmitter. Includes operating and programming instructions, and mounting hardware.

MCBL-7: DACT phone cord, 7 ft (2.13 m) long (two required).

ABS-8RB: Metal enclosure for externally mounting UDACT-2 up to 6,000 ft./1828.8 m from host FACP. 9.94" H x 4.63" W x 2.50" D (cm: 25.248 H x 11.760 W x 6.350 D).

UBS-1B: Metal enclosure with solid door, Black.

UBS-1BR: Metal enclosure with solid door, Red.

R-10E: SPDT Form-C relay. Contacts rated for 10 A @ 115 VAC. Connects to open collector relay driver.

R-20E: DPDT Two Form-C relays. Contacts rated for 10A @ 115 VAC. Connects to open collector relay driver.

FBD-1: Ferrite bead kit. Use for remote mounting only.

UL Listed Receivers

The chart below shows UL listed receivers compatible with the UDACT-2. A check in the protocol column indicates the receiver supports that protocol.

Receiver	4+2 Standard 1800/2300	Ademco Contact ID	SIA
Ademco 685 (1)	✓	✓	
Ademco MX8000 (2)	✓	✓	✓
Silent Knight 9500 (3)	✓	✓	✓
Silent Knight 9800 (4)	✓	✓	✓
FBI CP220FB (5)	✓	✓	✓
Osborne Hoffman 2000E (6)		✓	✓
Radionics 6600 (7)		✓	✓
SurGard MLR2 (8)	✓	✓	
SurGard System III (9)		✓	✓
SurGard MLR-2000 (10)		✓	

(1) With 685-8 Line Card with Rev 4.4d software

(2) With 124060V206B and 124063 Line Card Rev B

(3) With version V2.4 Receiver & 126047 Line Card Rev G

(4) With 124077V2.00 Receiver & 126047 Line Card Rev M

(5) With software V3.9

(6) With V.7301 Receiver S/W

(7) With 01.01.03 Receiver S/W & Line Card 01.01.03

(8) With software V1.86

(9) With software V1.72

(10) With DSP4016 and V1.6 Line Card

NOTIFIRENET™ is a trademark and Notifier® is a registered trademark of Honeywell International Inc.
©2012 by Honeywell International Inc. All rights reserved. Unauthorized use of this document is strictly prohibited.



This document is not intended to be used for installation purposes.
We try to keep our product information up-to-date and accurate.
We cannot cover all specific applications or anticipate all requirements.
All specifications are subject to change without notice.



Made in the U.S. A.

For more information, contact Notifier. Phone: (203) 484-7161, FAX: (203) 484-7118.
www.notifier.com

FCPS-24S6(C/E) & FCPS-24S8(C/E)

6- & 8-Amp 24-Volt Remote Power Supplies



Power Supplies

General

The FCPS-24S6E (6-amp) and FCPS-24S8E (8-amp) are remote power supplies with battery charger. The FCPS-24S6/-24S8 may be connected to any 12 or 24 volt fire alarm control panel (FACP) or may be used as stand-alone supplies. Primary applications include notification appliance circuit (NAC) expansion (to support ADA requirements and NAC synchronization) or auxiliary power to support 24 volt system accessories. The FCPS-24S6/-24S8 provides regulated and filtered 24 VDC power to four notification appliance circuits configured as either four Class B (Style Y) or Class A (Style Z, with ZNAC-4 option module). Alternately, the four outputs may be configured as all non-resettable, all resettable or two non-resettable and two resettable. The FCPS-24S6/-24S8 also contains a battery charger capable of charging up to 18 AH batteries. FCPS-24S6C & FCPS-24S8C are ULC-listed.

NOTE: Unless otherwise specified, the terms FCPS-24S6 and FCPS-24S8 used in this document refers to the standard FCPS-24S6 and FCPS-24S8, FCPS-24S6C and FCPS-24S8C, the FCPS-24S6E and FCPS-24S8E

Features

- UL-Listed NAC synchronization using System Sensor, Wheelock, or Gentex "Commander²" appliances.
- Operates as a "sync-follower" or as a "sync-generator" (default). See note on page 2.
- Contains two fully-isolated input/control circuits - triggered from FACP NAC (NAC expander mode) or jumped permanently "ON" (stand-alone mode).
- Four Class B (Style Y) or four Class A (Style Z, with ZNAC-4 module) NACs.
- 6-amp (FCPS-24S6) or 8-amp (FCPS-24S8) full load output, with 3 amps maximum/circuit, in NAC expander mode (UL 864).
- 4-amp (FCPS-24S6) or 6-amp (FCPS-24S8) continuous output in stand-alone mode (UL 1481).
- Compatible with coded inputs; signals passed through.
- Optional power-supervision relay (EOLR-1).
- In stand-alone mode, output power circuits may be configured as: resettable, (reset line from FACP required), non-resettable, or a mix of two and two.
- Fully regulated and filtered power output - optimal for powering four-wire smoke detectors, annunciators, and other system peripherals requiring regulated/filtered power.
- Power-limiting technology meets UL power-limiting requirements.
- Form-C normally-closed trouble relay.
- Fully supervised power supply, battery, and NACs.
- Selectable earth fault detection.
- AC trouble report selectable for immediate 2-hour delay.
- Works with virtually any UL 864 fire alarm control which utilizes an industry-standard reverse-polarity notification circuit (including unfiltered and unregulated NAC power).
- Requires input trigger voltage of 9 - 32 VDC.
- Self-contained in compact, locking cabinet - 15"H x 14.5"W x 2.75"D (cm: 38.1H x 36.83W x 6.985D).



- Includes integral battery charger capable of charging up to 18 AH batteries. Cabinet capable of housing 7.0 AH batteries.
- Battery charger may be disabled via DIP switch for applications requiring larger batteries.
- Fixed, clamp-type terminal blocks accommodate up to 12 AWG (3.1mm²) wire.

Specifications

Primary (AC) Power:

- FCPS-24S6C/-24S8C: 120 VAC, 60 Hz, 3.2A maximum.
- FCPS-24S6E/-24S8E: 240 VAC, 50 Hz, 1.6A maximum.
- Wire Size: minimum #14 AWG (2.0mm²) with 600 V insulation.

Control Input Circuit:

- **Trigger Input Voltage:** 9 to 32 VDC.
- **Trigger Current:** 2.0 mA (16 - 32 V); Per Input: 1.0 mA (9 - 16 V).

Trouble Contact Rating:

5 A at 24 VDC.

Auxiliary Power Output: Specific application power 500 mA maximum.

Output Circuits:

- +24 VDC filtered, regulated.
- 3.0 A maximum for any one circuit.
- Total continuous current for all outputs (stand-alone mode):
 - FCPS-24S6: 4.0 A maximum.
 - FCPS-24S8: 6.0 A maximum.
- Total short-term current for all outputs (NAC expander mode):
 - FCPS-24S6: 6.0 A maximum.
 - FCPS-24S8: 8.0 A maximum.

Secondary Power (Battery) Charging Circuit:

- Supports lead-acid batteries only.

- Float-charge voltage: 27.6 VDC.
- Maximum current charge: 1.5 A.
- Maximum battery capacity: 18 AH.

Applications

Example 1: Expand notification appliance power an additional 6.0 A (FCPS-24S6) or 8.0 A (FCPS-24S8). Use up to four Class B (Style Y) outputs or four Class A (Style Z) outputs (using ZNAC-4). For example, the FACP notification appliance circuits will activate the FCPS when reverse-polarity activation occurs. Trouble conditions on the FCPS are sensed by the FACP through the notification appliance circuit.

Example 2: Use the FCPS to expand auxiliary regulated 24-volt system power up to 4.0 A (FCPS-24S6) or up to 6.0 A (FCPS-24S8). Both resettable and non-resettable power options are available. Resettable outputs are created by connecting the resettable output from the FACP to one or both of the FCPS inputs.

Example 3: Use addressable control modules to activate the FCPS instead of activating it through the FACP notification appliance circuits. This typically allows for mounting the FCPS at greater distances* away from the FACP while expanding system architecture in various applications.

For example, an addressable control module is used to activate the FCPS, and an addressable monitor module is used to sense FCPS trouble conditions. Local auxiliary power output from the FCPS provides power to the addressable control module.

**NOTE: Addressable FACP's are capable of locating control and monitor modules at distances of up to 12,500 feet (3,810 meters).*

Sync Follower/Generator Note

In some installations, it is necessary to synchronize the flash timing of all strobes in the system for ADA compliance. Strobes accomplish this by monitoring very short timing pulses on the NAC power which are created by the FACP. When installed at the end of a NAC wire run, the FCPS-24S6/-24S8 can track (i.e. "follow") the strobe synchronization timing pulses on the existing NAC wire run. This maintains the overall system flash timing of the additional strobes attaches to the FCPS.

When the FCPS-24S6/-24S8 is configured (via DIP switch settings) as a "sync follower," the FCPS's NAC outputs track the strobe synchronization pulses present at the FCPS's sync input terminal. The pulses originate from an upstream FACP or other power supply.

When the FCPS-24S6/-24S8 are configured (via DIP switch settings) as a "sync generator," the FCPS's sync input terminals are not used. Rather, the FCPS is the originator of the strobe synchronization pulses on the FCPS's NAC outputs. In "sync generator" mode, the sync type (System Sensor, Wheelock, or Gentex) is selectable via DIP switch settings.

Standards and Codes

The FCPS-24S6 and FCPS-24S8 comply with the following standards:

- **NFPA 72** National Fire Alarm Code.
- **UL 864** Standard for Control Units for Fire Alarm Systems (NAC expander mode).
- **UL 1481** Power Supplies for Fire Alarm Systems.

Agency Listings and Approvals

These listings and approvals apply to the modules specified in this document. In some cases, certain modules or applications may not be listed by certain approval agencies, or listing may be in process. Consult factory for latest listing status.

- **UL Listed:** S635, S674
- **ULC Listed:** S635 (FCPS-24S6C & FCPS-24S8C)
- **CSFM Approved:** 7315-0028:225
- **MEA:** 299-02-E
- **FM Approved**

Ordering Information

FCPS-24S6: 6.0 A, 120 VAC remote charger power supply. Includes main printed circuit board, transformers, enclosure (15"H x 14.5"W x 2.75"D [cm: 38.1H x 36.83W x 6.985D]), and installation instructions.

FCPS-24S6C: Same as above, ULC-listed.

FCPS-24S6R: Same as FCPS-24S6 with red enclosure.

FCPS-24S6E: 6.0 A, 240 VAC remote charger power supply. Includes main printed circuit board, transformers, enclosure (15"H x 14.5"W x 2.75"D [cm: 38.1H x 36.83W x 6.985D]), and installation instructions.

FCPS-24S8: 8.0 A, 120 VAC remote charger power supply. Includes main printed circuit board, transformers, enclosure (15"H x 14.5"W x 2.75"D [cm: 38.1H x 36.83W x 6.985D]), and installation instructions.

FCPS-24S8C Same as above, ULC-listed.

FCPS-24S8R: Same as FCPS-24S8 with red enclosure.

FCPS-24S8E: 8.0 A, 240 VAC remote charger power supply. Includes main printed circuit board, transformers, enclosure (15"H x 14.5"W x 2.75"D [cm: 38.1H x 36.83W x 6.985D]), and installation instructions.

ZNAC-4: Class A (Style Y) NAC option module.

EOLR-1: 12/24 VDC end-of-line relay for monitoring four-wire smoke detector power.

BAT-1270: Battery, 12-volt, 7.0 AH (two required, see BAT Series data sheet DN-6933).

System Sensor® and NOTIFIER® are registered trademarks of Honeywell International Inc.

©2013 by Honeywell International Inc. All rights reserved. Unauthorized use of this document is strictly prohibited.



This document is not intended to be used for installation purposes.
We try to keep our product information up-to-date and accurate.
We cannot cover all specific applications or anticipate all requirements.
All specifications are subject to change without notice.



Made in the U.S. A.

For more information, contact Notifier. Phone: (203) 484-7161, FAX: (203) 484-7118.
www.notifier.com

First Command

NFC-50/100(E)



Voice Evacuation & Emergency Communications System

General

Notifier's First Command NFC-50/100 and NFC-50/100E are multipurpose emergency voice evacuation panels for fire applications, mass notification applications, or both. The First Command delivers 50 or 100 watts of audio power for distribution up to eight speaker circuits (i.e. zones). The NFC-50/100(E) comes standard with a single speaker circuit and a built-in 50 watt, 25V amplifier. A secondary 50 watt amplifier (NFC-BDA-25/70V) can be added for single speaker circuit backup or to increase system capacity to two speaker circuits and an additional 50 watts of audio power. An optional NFC-CE6 module added to the NFC-50/100(E) will upgrade the system to a maximum of eight speaker circuit outputs. All speaker output circuits can be wired in either Style Y (Class B) or Style Z (Class A) configuration. The NFC-50/100(E) has fourteen field programmable messages (up to 60 seconds each), built-in field configurable pre- and post-announce tone generators and a fully supervised Notification Appliance Circuit (NAC) with 2.0 amps of synchronized NAC power. The NFC-50/100(E) includes three built-in Form-C relay contacts, (AC power, trouble and MNS active) a NAC follower and 500mA special application power. A built-in power supply delivers operational power and on board battery charger supports charging up to 26AH batteries (NFC cabinet holds up to 18AH batteries).

For fire protection applications, the NFC-50/100(E) is an adjunct (slave) to most UL listed FACP's or as a stand-alone unit for non-fire applications. For seamless integration between fire and mass notification, the NFC-50/100(E) can be activated by the NFW2-100(Rev 3) and NFW-50 when connected to the ACS/ANN serial communication bus. Activation of the NFC-50/100(E) via other FACP's uses the eight on board Command Input Circuits (CMD's). Two of the eight CMD circuits (CMD 1 & CMD 2) can be individually field programmed for activation by an FACP Notification Appliance Circuit reverse polarity and all eight can be activated by a contact closure. In addition, the NFC-50/100(E) can be activated from a building's Private Branch Exchange (PBX) with the integral night ring feature.

All NFC-50/100(E) programming is done by using a simple, built-in programming utility accessed from any laptop. For added flexibility, the NFC-50/100(E) supports both 25V and 70V speaker output operation. By adding a 70V transformer conversion module (NFC-XRM-70V) or an additional 70 volt secondary amplifier (NFC-BDA-25/70V) the system supports 70 volt speaker devices.

The NFC-50/100(E) can expand in order to accommodate larger or more complex installations. To add more control and increase system capacity, any combination of up to eight external remote consoles (including the NFC-LOC, NFC-RPU, and NFC-RM) and up to eight distributed audio amplifiers (including the NFC-50DA(E) and NFC-125-DA(E)) can be connected on the external data bus and audio riser data bus to create a fully integrated command center. A fully loaded system supports up to 1100 watts of total audio power and up to 24 speaker circuit outputs.



TYPICAL APPLICATIONS

- Schools
- Nursing Homes
- Factories
- Theaters
- Military facilities
- Restaurants
- Auditoriums
- Places of Worship
- Office Buildings

Features

- UL Listed to UL 2572 Communication (Control Units Mass Notification Systems) and UL 864 (emergency voice evacuation for fire).
- Modular design for system flexibility and easy expansion.
- Removable terminal blocks.
- 50 watts of 25V audio power (expandable to 100 watts) RMS.
- 2 amp Notification Appliance Circuit (NAC) output, sync generator, or follower for System Sensor, Wheelock or Gen-tex protocols.
- Optional 70V transformer available for the primary amplifier. (Note that speaker wiring continues to be supervised in standby, alarm and when background music is playing with this optional transformer installed).
- Eight Command Input Circuits to activate messages 1 to 8:
 - CMD1 and CMD2 are field selectable to be activated from 12 or 24 VDC Notification Appliance Circuits (reverse polarity) or contact closures.
 - CMD3-CMD8 are activated by contact closures.
- Speaker Circuits.
 - Single Style Y (Class B) or Style Z (Class A) speaker Circuit.

- Two Style Y (Class B) or Style Z (Class A) speaker circuits (with optional NFC-BDA-25/70V Audio Amplifier installed).
- Eight Style Y (Class B) or Style Z (Class A) speaker circuits (with optional NFC-BDA-25/70V and NFC-CE6 installed).
- NFC-50/100(E) can be controlled by an FACP via the ANN/ACS (EIA-485) link of the NFW2-100 (Rev 3).
- Integral supervised microphone.
- Microphone time-out feature which reverts back to pre-recorded message if emergency page exceeds the programmed time.
- 14 recorded messages.
- Field-selectable message and custom message recording capability using the local microphone, a USB port, or an external audio input.
- External Audio Input can be used for background music.
- Up to 60 second message duration for all messages.
- Integral tone generators field selectable for multiple tone types.
- Powered by integral AC power supply or batteries during AC fail.
- Programmable delay of immediate, 2 hours or 6 hours reporting of AC Loss.
- Piezo sounder for local trouble.
- 100 event history log.
- Three Form-C relays:
 - AC Power Loss Relay - TB1.
 - System Trouble Relay - TB2.
 - MNS Active - TB3.
- 500mA (0.5A) Special Application (auxiliary power) output for addressable modules when interfaced with compatible addressable FACP's and End-of-Line power supervision relays.
- System Status LEDs (refer to "Controls and Indicators" on product manual LS10001-000NF-E).
- Integral Dress Panel.
- Optional TR-CE-B semi-flush trim ring.
- Any combination of up to eight (8) external remote consoles:
 - Optional NFC-RM Remote Microphone (includes cabinet). See DN-60778.
 - Optional NFC-RPU Remote Page Unit (includes cabinet). See DN-60775.
 - Optional NFC-LOC Local operator console (includes cabinet). See DN-60777.
- Any combination of up to eight (8) distributed audio amplifiers:
 - Optional NFC-50DA(E) distributed amplifier, 50 watts. See DN-60776.
 - Optional NFC-125DA(E) distributed amplifier, 125 watts. See DN-60776.

Optional Internal Expansion Modules

NFC-CE6: Circuit Expander Module provides connections for up to six Style Z (Class A) or Style Y (Class B) speaker circuits. Circuits are configured through the web-based programming utility.

NFC-BDA-25V: 25V, 50 watt audio amplifier module. Adding a second speaker circuit increases the total NFC-50/100 power output to 100 watts or can also be used as a backup amplifier.

NFC-BDA-70V: 70V, 50 watt audio amplifier module. Adding a second speaker circuit increases the total NFC-50/100 power output to 100 watts or can also be used as a backup amplifier.

NFC-XRM-70V: 70V Transformer Conversion Module. Converts the NFC-50/100(E) primary amplifier to a 70V output. This transformer mounts directly to the NFC-50/100(E) main control board by two metal brackets.

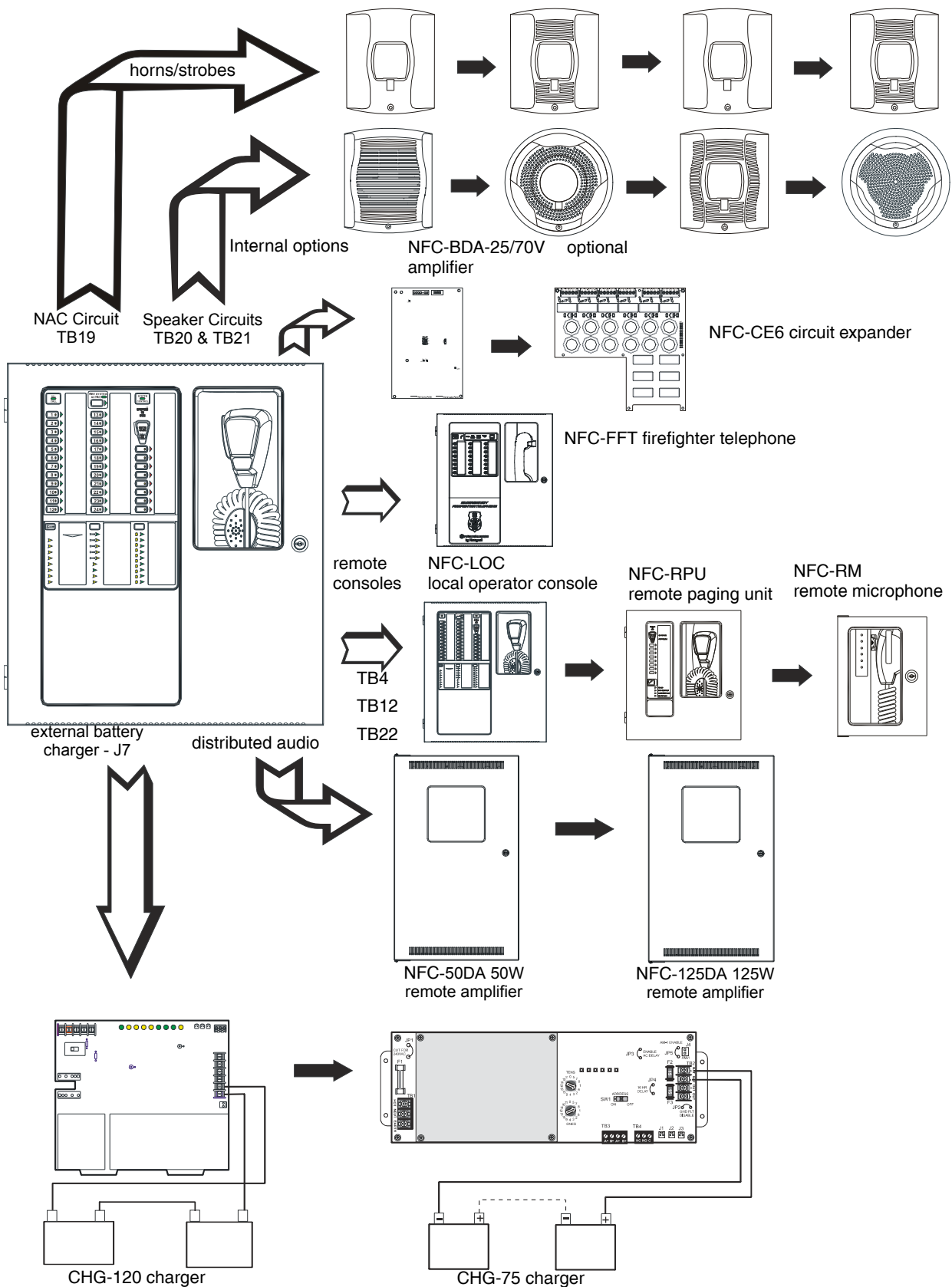

NFC-50/100(E) FirstCommand (Possible Configurations)

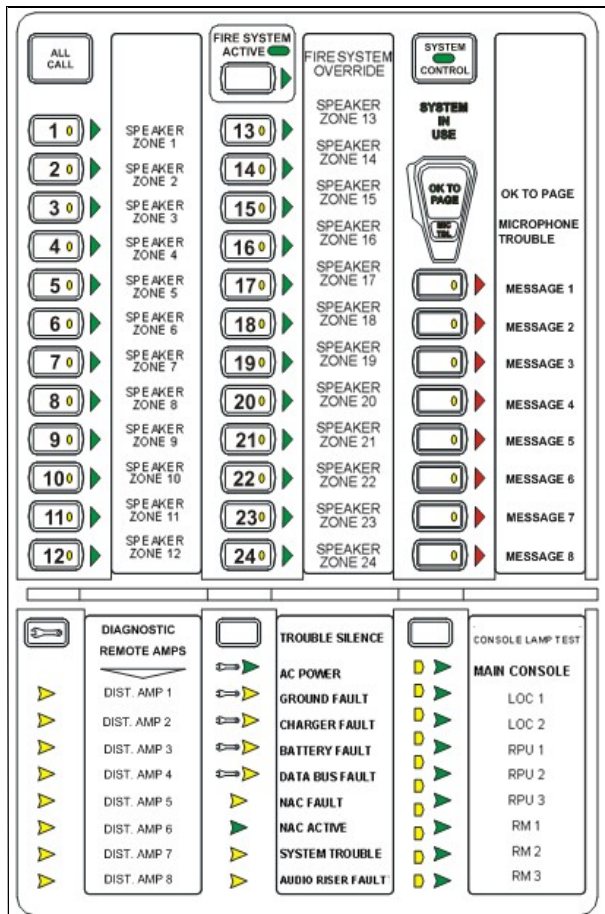

Control and Indicators

PUSH BUTTON CONTROLS

- All Call
- MNS Control
- System Control
- Speaker Select 1-24
- Message Select 1-14
- Diagnostic Select
- Trouble Silence
- Console Lamp Test

LED Status Indicators (visible with door closed)

- Fire System Active (green)
- MNS Control (green)
- System Control (green)
- System in Use (green)
- Speaker Zone 1-24 Active (green)
- Speaker Zone 1-24 Fault (yellow)
- OK to Page (green)
- Microphone Trouble (yellow)
- Message 1-8 Active (red)
- Message 1-8 Fault (yellow)
- Remote Amplifier 1-8 Fault (yellow)
- LOC/RPU/RM 1-8 Fault (yellow)
- LOC/RPU/RM 1-8 Active (green)
- Main Console Fault (yellow)
- AC Power (green)
- Ground Fault (yellow)
- Charger Fault (yellow)
- Battery Fault (yellow)
- Data Bus Fault (yellow)
- NAC Fault (yellow)
- NAC Active (green)
- System Trouble (yellow)
- Audio Riser Fault (yellow)

LED Indicators (visible with door and dress panel open)

- Speaker Volume Control Fault (yellow).
- Option Card Fault (yellow).
- Amplifier Over Current Fault (yellow).

Product Line Information

NFC-50/100: (Primary Operating Console) 50 Watt, 25V single speaker zone emergency voice evacuation system, integral microphone, built in tone generator and 14 recordable messages.

NFC-50/100E: Export version (Primary Operating Console) 50 Watt, 25V single speaker zone emergency voice evacuation system, integral microphone, built in tone generator and 14 recordable messages. (240 VAC, 50Hz).

NFC-CE6: Speaker Circuit/Zone Expander Module.

NFC-BDA-25V: 25V, 50 watt audio amplifier module. Adding a second speaker circuit increases the total NFC-50/100 power output to 100 watts or can also be used as a backup amplifier.

NFC-BDA-70V: 70V, 50 watt audio amplifier module. Adding a second speaker circuit increases the total NFC-50/100 power output to 100 watts or can also be used as a backup amplifier.

NFC-XRM-70V: 70V Transformer Conversion Module. Converts the NFC-50/100(E) primary amplifier to a 70V output. This transformer mounts directly to the NFC-50/100(E) main control board by two metal brackets.

NFC-LOC: Local Operator Console (Complete user interface), *Please refer to the data sheet DN-60777 for more information.*

NFC-RPU: Remote Page Unit Hand held microphone, 14 message buttons. *Please refer to the data sheet DN-60775 for more information.*

NFC-RM: Remote Microphone only. *Please refer to the data sheet DN-60778 for more information.*

NFC-50DA: Distributed (Remote) Audio Amplifier, 50 watts. *Please refer to the data sheet DN-60776 for more information.*

NFC-50DAE: Export version. Distributed (Remote) Audio Amplifier, 50 watts. (240 VAC, 50Hz). *Please refer to the data sheet DN-60776 for more information.*

NFC-125DA: Distributed (Remote) Audio Amplifier, 125 watts. *Please refer to the data sheet DN-60776 for more information.*

NFC-125DAE: Export version. Distributed (Remote) Audio Amplifier, 125 watts. (240 VAC, 50Hz). *Please refer to the data sheet DN-60776 for more information.*

NFC-CE4: Distributed Audio Speaker Circuit/Zone expander module.

NFC-FFT: Fire Fighter Telephone System. *Please refer to the data sheet DN-60779 for more information.*

N-FPJ: Remote Phone Jack.

FHS-F: Fire Fighters Remote Handset.

FHSC-R: Fire Fighters Handset Cabinet Recessed.

FHSC-S: Fire Fighters Handset Cabinet Surface Mount

TR-CE-B: Optional Trim Ring.

THUMBLTCH: Optional Thumb Latch. (Non UL-Listed).

CHG-75: 25 to 75 ampere-hours (AH) External Battery Charger.

CHG-120: 25-120 ampere-hours (AH) External Battery Charger.

ECC-MICROPHONE: Replacement Microphone only.

BAT-1270: Battery, 12 volt, 7.0 AH (Two required).

BAT-12120: Battery, 12 volt, 12.0 AH (Two required).

BAT-12180: Battery, 12 volt, 18.0 AH (Two required).

BAT-12260: Battery, 12 volt, 26.0 AH (Two required).

BB-26: Battery cabinet mounts up to two 26 AH batteries.

Wiring Requirements

See product manual, part number LS10001-001NF-E for detailed wiring requirements.

Total System Capacity: (NFC-50/100(E) only)

- Total Built-in Audio Power: 50 Watts.
- Total Expandable Audio Power: 100 Watts.
- Total Built-in Speaker Circuits: 2.
- Total Expandable Speaker Circuits: 8.
- Audio Message Max Time Duration: 60 seconds.
- External Audio Input: 1.

Total System Capacity: (Fully Loaded System)

- Total Distributed Audio Power: 1100 Watts.
- Total Speaker Circuits Per System: 24.
- Total Remote Consoles Supported: 8.
- Total Distributed Audio Amplifiers Supported: 8.

Electrical Specifications

PRIMARY (AC) POWER (TB15)

NFC-50/100: 120 VAC, 60 Hz, 3.5 amps.

NFC-50/100E: 240 VAC, 50 Hz, 2.0 amps.

Wire size: minimum #14 AWG (2.00mm²) with 600 V insulation.

SECONDARY POWER (BATTERY) CHARGING CIRCUIT (J7)

- Supports lead-acid batteries only.
- Float charge voltage at 27.3V
- Maximum charge current: 1.0 Amp
- Maximum battery charge capability: 2.8 Amps, 26AH (NFC cabinet holds max. 18AH battery).

- Minimum Battery size: 12 Amp Hour.

AC LOSS RELAY CONTACT RATING (TB3)

- 2.0 amps @ 30 VDC (resistive), 0.5 amps @ 30 VAC (resistive).

FORM C - TROUBLE RELAY CONTACT RATING (TB2)

- 2.0 amps @ 30 VDC (resistive), 0.5 amp @ 30 VAC (resistive).

MNS ACTIVE RELAY CONTACT RATING (TB1)

- 2.0 amps @ 30 VDC (resistive), 0.5 amps @ 30 VAC (resistive).

NOTIFICATION APPLIANCE CIRCUIT (NAC) OUTPUT RATING (TB19)

- One (1) Style Y (Class B) or Style Z (Class A) circuit.
- Power-limited circuitry, (Class 2) supervised.
- Nominal operating voltage: 24 VDC.
- Maximum signaling current for special application power: 2.0A.
- Maximum signaling current for regulated power: 200mA.
- Maximum wiring impedance: 1Ω.
- Current limit: fuse-less, electronic, power-limited.
- End-Of-Line Resistor: 4.7 KΩ, ½ watt, (P/N 71252) required for Style Y (Class B) operation.

Refer to the Device Compatibility Document 15378 for listed compatible devices.

NAC FOLLOWER OUTPUT REMOTE SYNC (TB18)

- Connections for FACP NAC synchronization trigger signal.
- Output terminals: pass-through to other system components.
- Trigger input voltage: 9 to 32 VDC, 24 VDC rated.
- Input current draw in Alarm condition: 10 mA at rated voltage.

SPECIAL APPLICATION POWER (AUX. POWER) (TB17)

- 500 mA @ 24 VDC.
- Used for powering addressable modules and associated End-of-Line power supervision relays.

Power-limited circuitry. Refer to the Device Compatibility Document 15378 for a list of compatible devices.

SPEAKER VOLUME CONTROL OVERRIDE (TB23)

- Style Y (Class B) or Style Z (Class A) circuit.
- Special application power.
- Power-limited circuitry, supervised.
- Nominal operating voltage: 24 VDC.
- Maximum signaling current: 0.25 amps.
- Current limit: fuse-less, electronic, power-limited.
- End-Of-Line Resistor: 4.7 KΩ, ½ watt, (P/N 71252) required for Style Y (Class B) operation.

Speaker Circuits

- Primary Speaker Circuit (TB20)
- Secondary Speaker Circuit (TB21) (with optional amplifier only).
 - Circuit can be wired Style Y (Class B) or Style Z (Class A).
 - Power-limited circuitry.
 - Normal Operating Voltage: 25 VRMS @ 2 amps max and maximum Load Impedance of 12.5Ω (70V @ 700 mA max. with maximum load Impedance of 100Ω operation possible by plugging optional NFC-XRM-70V conversion transformer into J12 of the main control board).

- Output Power: 50 watts (10 watts when background music is employed).
- Frequency Range: 400Hz - 4,000Hz.
- Maximum total capacitance for each speaker circuit: 250 μ F.
- End-of-Line Resistor required for Style Y circuit: 15 K Ω , 1 watt (P/N: ELR-15K).

Command Input Circuits (alarm polarities shown)

CMD1 - TB4 Terminals 3(+) & 4(-) are input terminals and Terminals 1(-) and 2(+) are output terminals which provide feed through of the NAC circuits to NAC devices down stream.

CMD2 - TB5 Terminals 3(+) & 4(-) are input terminals and Terminals 1(-) and 2(+) are output terminals which provide feed through of the NAC circuits to NAC devices downstream.

CMD3 - TB6 Terminals 1(+) & 2(-) are input terminals for contact closure only.

CMD4 - TB6 Terminals 3(+) & 4(-) are input terminals for contact closure only.

CMD5 - TB7 Terminals 1(+) & 2(-) are input terminals for contact closure only.

CMD6 - TB7 Terminals 3(+) & 4(-) are input terminals for contact closure only.

CMD7 - TB8 Terminals 1(+) & 2(-) are input terminals for contact closure only.

CMD8 - TB8 Terminals 3(+) & 4(-) are input terminals for contact closure only.

- Power-limited and supervised circuitry.
- Normal Operating Voltage Range: 10.5 VDC - 29 VDC; (Maximum Voltage: 29 VDC).
- NAC Reverse Polarity Current (requires End-of-Line Resistor from NAC): 1.6 mA maximum.
- Contact Closure Operation Current (requires 4.7K Ω , ½ watt End-of-Line Resistor P/N 27072): 6.6 mA maximum.
- Maximum Wiring Impedance CMD1 - CMD8 (Contact Closure Operation): 200 Ω .

NOTE: When the system is programmed for Mass Notification, CMD1 and CMD2 will be programmed for Reverse Polarity only. See manual P/N LS10001-001NF-E for more details.

MAXIMUM INPUT IMPEDANCE:

- CMD1 & CMD2 (Reverse Polarity Operation): 20K Ω .
- CMD1 - CMD8 (Contact Closure Operation): 4.75K Ω .

NIGHT RING INPUT - TB16, TERMINALS 1 (+) & 2 (-)

- Contact closure input.
- Isolated, non-supervised.
- Operation current: 3.8 mA, maximum.
- Maximum wiring impedance: 30K Ω .
- Minimum isolation withstand voltage: 1500 VRMS.

EXTERNAL OPERATOR INTERFACE POWER OUTPUT (TB24)

- Non-resettable power for external operator interface components.
- Power-limited circuitry, non-supervised.
- Nominal operating voltage: 24 VDC.
- Maximum output current: 0.80 amps.
- Current limit: fuse-less, electronic, power-limited circuit.

EXTERNAL DATA BUS (EIA-485) (TB12)

- Data connections for external operator interface components.

- Redundant transceiver circuitry for Class A operability.
- Power-limited circuitry, supervised.
- Maximum wiring impedance: 13.2 Ω .

FACP DATA BUS (EIA-485) (TB13)

- Dedicated connection to FACP serial bus.
- Output terminals: pass-through to other system components.
- Isolated, supervised.
- Minimum isolation withstand voltage: 1500 VRMS.
- Maximum wiring impedance: 40 Ω (ANN-BUS), 26 Ω (ACS-BUS).
- External Audio Riser (TB22).
- Style Y (Class B) or Style Z (Class A) audio connections to external operator interface components.
- Power-limited circuitry, supervised.
- Audio signal level: 3.85 V, maximum.
- Frequency range: 400 Hz - 4 KHz RMS.
- Frequency range (NFC-50/125DA): 800Hz - 2KHz RMS.

EXTERNAL AUDIO INPUT (TB5)

- Input Impedance: 8.5K Ω nominal @1KHz.
- Input Voltage: 700 mV rms maximum.
- Input Current: 0.1 mA maximum @ 700 mV.

NOTE: Some laptops/personal computers only provide an audio output for headphones. It may be necessary to adjust the headphone output level for proper recording of voice messages.

NFC-CE6 Circuit Expander Module Specifications

- Power-limited circuitry.
- Up to six (6) circuits on the NFC-CE6 can be wired as Style Y (Class B) or Style Z (Class A).
- Normal Operating Voltage for Speaker Circuits: 25 V @ 2.0 amps max. (Maximum Load Impedance of 12.5 Ω).
- 70.0 V @ 700 mA max. with maximum Load Impedance of 100 Ω operation possible for the primary circuit by plugging in an optional NFC-XRM-70V conversion transformer into J12 of the main control board. The same operation is possible for the optional 50W amplifier by selecting the NFC-BDA-70V model.
- Speaker circuit wiring is supervised during standby, background music, and alarm.
- Output Power: 50 watts total; Frequency Range: 400Hz - 4,000Hz.
- Maximum total capacitance: 250 μ F. (Note that the total capacitance for the speaker outputs must not exceed the maximum of 250 μ F).
- End-of-Line Resistor required for Style Y (Class B) speaker circuit: 15 K Ω , 1 watt (P/N: ELR-15K)TB13 on the main control board: ACS/ANN (EIA-485) electrically isolated link to FACP provides programmed speaker control.

Cabinet Specifications

Backbox: 19.0"(48.26 cm) high x 16.65"(42.29 cm) wide x 5.20"(13.23 cm) deep.

Door: 19.26" (48.92 cm) high x 16.82"(42.73 cm) wide x 0.12"(0.30 cm) deep.

Trim Ring (TR-CE-B): 22.00" (55.88 cm) high x 19.65" (49.91 cm) wide.

Shipping Specifications

Base Unit Weight: 27.85 lbs (12.63 kg).

Temperature and Humidity ranges

This system meets NFPA requirements for operation at 0-49° C/32-120° F and at a relative humidity 93% ± 2% RH (non-condensing) at 32°C ± 2°C (90°F ± 3°F). However, the useful life of the system's standby batteries and the electronic components may be adversely affected by extreme temperature ranges and humidity. Therefore, it is recommended that this system and its peripherals be installed in an environment with a normal room temperature of 15-27° C/60-80° F.

Agency Listings and Approvals

The listings and approvals below apply to the basic NFC-50/100(E) control panel. In some cases, certain modules may not be listed by certain approval agencies or listing may be in process. Consult factory for latest listing status.

- UL Listed S635.
- Compliant with UFC 4-021-01.

Standards and Codes

The NFC-50/100(E) complies with the following UL Standards and with NFPA 72 Fire Alarm system requirements.

- UL 864.
- UL 2572.

Notifier® is a registered trademark of Honeywell International Inc.
©2013 by Honeywell International Inc. All rights reserved. Unauthorized use
of this document is strictly prohibited.



This document is not intended to be used for installation purposes.
We try to keep our product information up-to-date and accurate.
We cannot cover all specific applications or anticipate all requirements.
All specifications are subject to change without notice.



Made in the U.S. A.

For more information, contact Notifier. Phone: (203) 484-7161, FAX: (203) 484-7118.
www.notifier.com

FirstCommand

NFC-RM Remote Microphone



External Remote Console

General

Notifier's First Command NFC-RM is an optional Remote Microphone that is compatible with the NFC-50/100(E) Emergency Voice Evacuation for fire protection applications. It is part of a family of external remote consoles that allows for extending the operator interface to remote locations within a building. It is housed in a cabinet with a keyed lock to limit access to qualified personnel.

The NFC-RM remote microphone allows for ALL CALL paging to be broadcast over the speaker circuits when depressing the microphone's push-to talk switch. The RM requires an external data bus connection, an external audio riser connection, and an external operator interface power connection (24 Volts DC) from the NFC-50/100 main console.

TYPICAL APPLICATIONS

- Schools
- Nursing Homes
- Factories
- Theaters
- Military facilities
- Restaurants
- Auditoriums
- Places of Worship
- Office Buildings

Features

- External remote console that provides ALL CALL paging broadcasts over the speaker zones of the NFC-50/100(E) primary operating console.
- Modular design for maximum system flexibility and easy expansion.
- Supports both Class A (Style Z) and Class B (Style Y) wiring.
- A maximum of eight NFC-RM's can be connected to an NFC-50/100(E) primary operating console.
- Built-in microphone with push-to-talk feature that can be used for ALL CALL paging.
- Sturdy cabinet design with a keyed lock to prevent unauthorized access. Optional thumb lock is available.
- Simple and straightforward user interface.

Electrical Specifications

PRIMARY POWER REQUIREMENTS:

Voltage 24VDC non-resettable power from the NFC-50/100(E). External Operator Interface Power (Non-supervised).

See NFC-50/100(E) Product Manual P/N LS10001-001NF-E for standby and alarm current requirements as well as battery calculations.

Wiring Requirements

See Product Installation Document PN: LS10029-000FL-E for detailed wiring requirements.

Agency Listings and Approvals

The listings and approvals below apply to the basic NFC-50/100(E) Fire emergency voice evacuation system. In some cases, certain modules may not be listed by certain approval



agencies or listing may be in process. Consult factory for latest listing status.

UL Listed S635.

Standards and Codes

The NFC-RM complies with NFPA 101 Life Safety Code and with the following UL Standards and with NFPA 72 Fire Alarm system requirements.

UL 864.

Temperature and Humidity ranges

This system meets NFPA requirements for operation at 0-49° C/32-120° F and at a relative humidity 93% ± 2% RH (non-condensing) at 32°C ± 2°C (90°F ± 3°F). However, the useful life of the system's standby batteries and the electronic components may be adversely affected by extreme temperature ranges and humidity. Therefore, it is recommended that this system and its peripherals be installed in an environment with a normal room temperature of 15-27° C/60-80° F.

Cabinet Specifications

8.3" (21.082 cm) high x 6.080" (15.44 cm) wide x 4.337" (11.02 cm) deep (Door attached and closed).

Shipping Specifications

Weight: 4 lbs (1.81 kg).

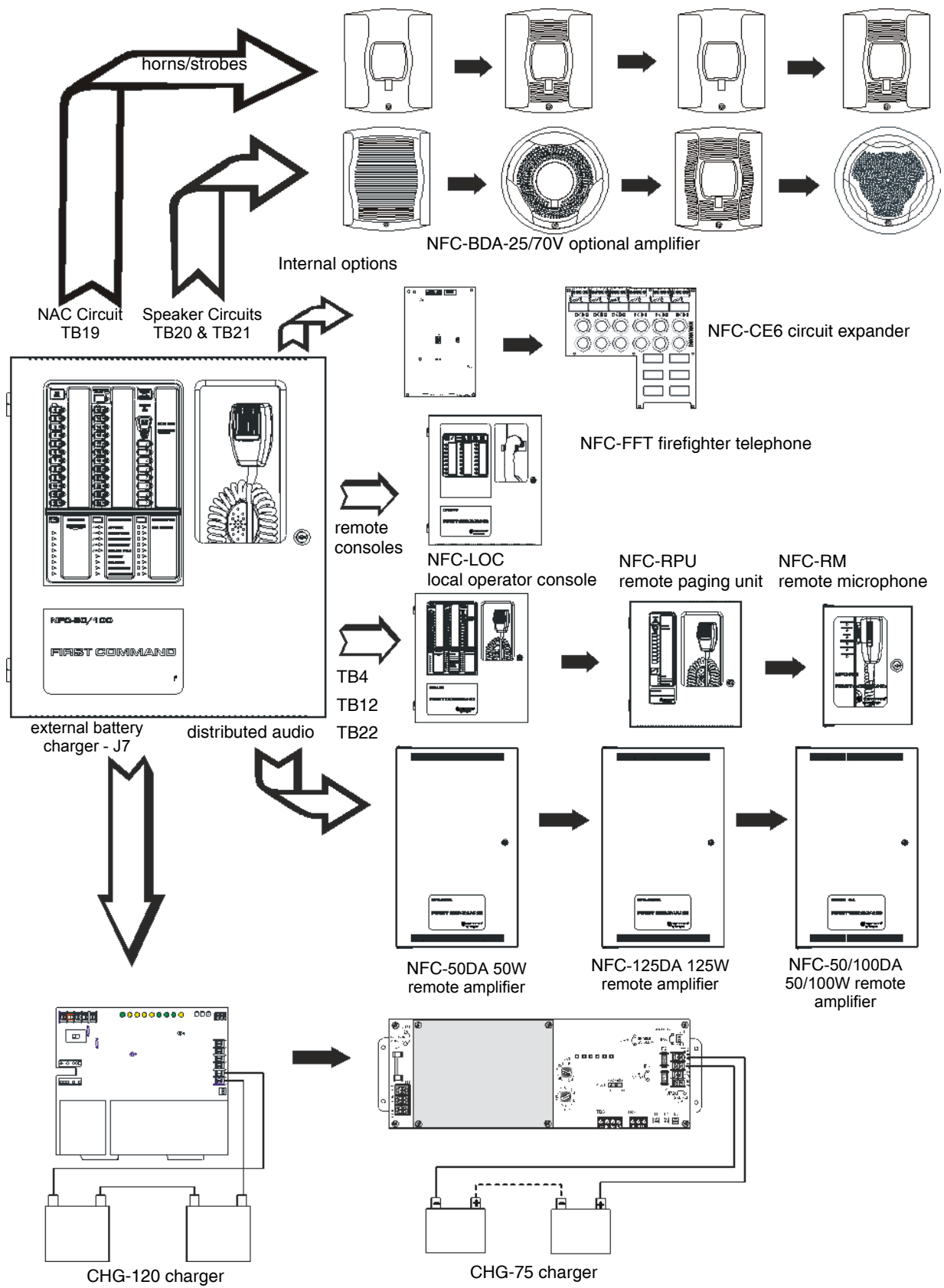

NFC-50/100(E) FirstCommand (Possible Configurations)

Control and Indicators

PUSH BUTTON CONTROLS

- Microphone
- Push to talk switch

LED STATUS INDICATORS (VISIBLE WITH DOOR CLOSED)

- System in Use (green)
- OK to Page (green)
- AC Power (green)
- Data Trouble (yellow)
- Audio Trouble (Yellow)
- Microphone Trouble (yellow)

Product Line Information (Ordering Information)

NFC-RM: Remote Microphone only.

NFC-50/100: (Primary operating Console) 50 Watt, 25VRMS single speaker zone emergency voice evacuation system, Integral microphone, built in tone generator and 14 recordable messages. *Please refer to the data sheet DN-60772 for more information.*

NFC-50/100E: Export version (Primary operating Console) 50 Watt, 25VRMS single speaker zone emergency voice evacuation system, Integral microphone, built in tone generator and 14 recordable messages, 240 VAC, 50Hz. *Please refer to the data sheet DN-60772 for more information.*

N-FPJ: Remote Phone Jack.

ECC-MICROPHONE: Replacement Microphone Only.

CHG-75: 25 to 75 ampere-hours (AH) external battery charger.

THUMBLTCH: Optional Thumb Latch. (Non UL Listed).

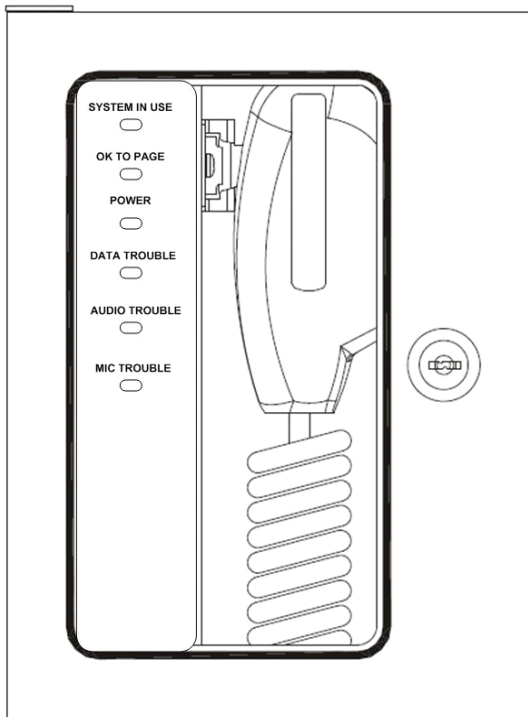

Notifier® is a registered trademark of Honeywell International Inc.
©2014 by Honeywell International Inc. All rights reserved. Unauthorized use
of this document is strictly prohibited.



This document is not intended to be used for installation purposes.
We try to keep our product information up-to-date and accurate.
We cannot cover all specific applications or anticipate all requirements.
All specifications are subject to change without notice.



Made in the U.S. A.

For more information, contact Notifier. Phone: (203) 484-7161, FAX: (203) 484-7118.
www.notifier.com

BAT Series Batteries

Sealed Lead-Acid or Gell Cell



Power Supplies

General

BAT Series Batteries feature a new part-numbering/listing system — providing an improved method of delivery for NOTIFIER-approved sealed lead-acid batteries for all your fire alarm system needs. Multiple brands of batteries are now offered under generic part numbers, reducing backorder situations and permitting us to deliver these products in a more timely fashion. NOTIFIER has approved the multiple brands listed below as possible product shipped for a given part number. Please note that any incoming orders for “PS Series” batteries will be converted to the equivalent BAT Series part numbers.



6933cov.jpg

Features

- Provide secondary power for control panels.
- Sealed and maintenance-free.
- Overcharge protected.
- Easy handling with leakproof construction.
- Ruggedly constructed, high-impact case (ABS, polystyrene, or polypropylene, depending on models).
- Long service life.
- Compact design.

Agency Listings and Approvals

The listings and approvals below apply to BAT Series Batteries. In some cases, certain modules may not be listed by certain approval agencies, or listing may be in process. Consult factory for latest listing status.

- **UL Recognized Components:** files MH19884 (*B & B Battery*), MH20567 (*UPG, previously Jolt*), MH20845 (*Power-Sonic*).

Part Number Reference

CURRENT Part Number	BATTERY DESCRIPTION	ALTERNATES APPROVED: manufacturers and P/Ns shipped under BAT P/Ns
BAT-1250	12 V, 5 AH, sealed.	BP5-12 (B&B Battery); PS-1250 (Power-Sonic); SA1250 (Jolt) to be replaced with UB1250 (UPG).
BAT-1250	12 V, 5 AH, sealed.	BP5-12 (B&B Battery); PS-1250 (Power-Sonic); SA1250 (Jolt) to be replaced with UB1250 (UPG).
BAT-1270	12 V, 7 AH, sealed.	BP7-12 (B&B Battery); PS-1270 (Power-Sonic); SA1272 (Jolt) to be replaced with UB1270 (UPG).
BAT-12120	12 V, 12 AH, sealed.	BP12-12 (B&B Battery); PS-12120 (Power-Sonic); SA12120 (Jolt) to be replaced with UB12120 (UPG).
BAT-12180	12 V, 18 AH, sealed.	PS-12180 (Power-Sonic); SA12180 (Jolt) to be replaced with UB12180 (UPG).
BAT-12180	12 V, 18 AH, sealed.	PS-12180 (Power-Sonic); SA12180 (Jolt) to be replaced with UB12180 (UPG).
BAT-12260	12 V, 26 AH, sealed.	BP26-12 (B&B Battery); PS-12260 (Power-Sonic); SA12260 (Jolt) to be replaced with UB12260 (UPG).
BAT-12550	12 V, 55 AH, sealed.	PS-12550 (Power-Sonic); XSA12550 (Jolt) to be replaced with UB12550 (UPG).
BAT-12550	12 V, 55 AH, sealed.	PS-12550 (Power-Sonic); XSA12550 (Jolt) to be replaced with UB12550 (UPG).
BAT-121000	12 V, 100 AH, gell cell.	PS-121000 (Power-Sonic); XSA121000A (Jolt) to be replaced with UB121000 (UPG).

POWER-SONIC

Part Number Reference

1109t1.tbl

MODEL	Nominal Voltage V	Nominal Capacity @ 20 hr. rate A.H.	Discharge Current @20 hr. rate mA	DIMENSIONS									
				Width		Depth		Height		Height over terminal		Weight	
				in.	mm	in.	mm	in.	mm	in.	mm	lb.	kg.
PS-1250	12	5	250	3.54	90	2.76	70	4.02	102	4.21	107	4.1	1.9
PS-1270	12	7	325	5.94	151	2.56	65	3.7	94	3.86	98	5.7	2.6
PS-12120	12	12	600	5.94	151	3.86	98	3.7	94	3.86	98	8.8	4
PS-12180	12	18	875	7.13	181	2.99	76	6.57	167	6.57	167	12.8	5.8
PS-12250	12	25	1300	6.89	175	6.54	166	4.92	125	4.92	125	18.7	8.5
PS-12550	12	55	3000	10.25	260	6.6	168	8.2	208	9.45	240	39.7	18
PS-121000	12	100	5000	12	305	6.6	168	8.2	208	9.45	240	65.7	29.8

Characteristic Discharge Curves

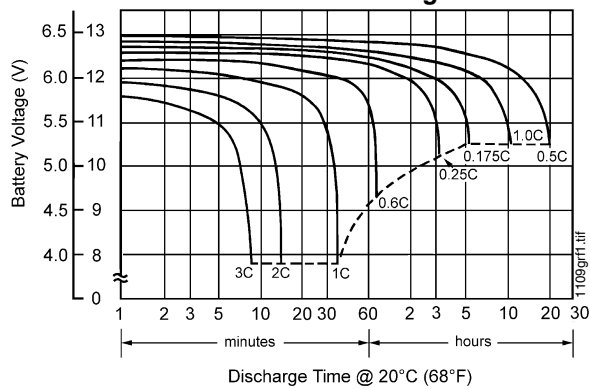

Effect of Temperature on Capacity

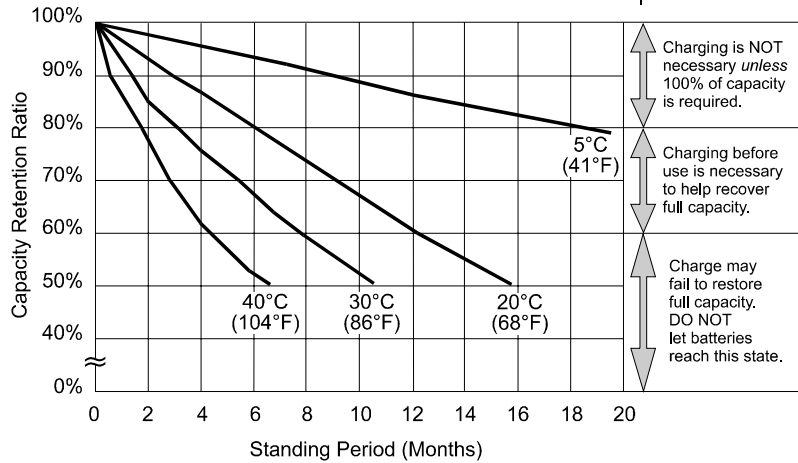
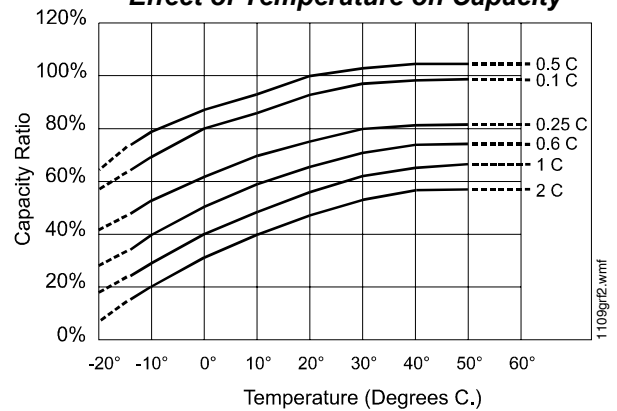

**at left:
PS-121000
Shelf-Life
and Storage**

Charging is NOT necessary unless 100% of capacity is required.

Charging before use is necessary to help recover full capacity.

Charge may fail to restore full capacity. DO NOT let batteries reach this state.

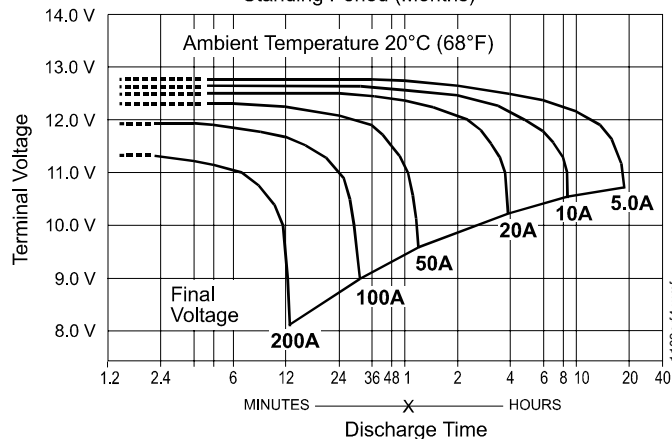

**at left:
PS-121000
Discharge
Characteristics**

NBG-12LX

Addressable Manual Pull Station



Intelligent/Addressable Devices

General

The Notifier NBG-12LX is a state-of-the-art, dual-action (i.e., requires two motions to activate the station) pull station that includes an addressable interface for any Notifier intelligent control panel except FireWarden series panels, and the NSP-25 panel. Because the NBG-12LX is addressable, the control panel can display the exact location of the activated manual station. This leads fire personnel quickly to the location of the alarm.

Features

- Maintenance personnel can open station for inspection and address setting without causing an alarm condition.
- Built-in bicolor LED, which is visible through the handle of the station, flashes in normal operation and latches steady red when in alarm.
- Handle latches in down position and the word “ACTIVATED” appears to clearly indicate the station has been operated.
- Captive screw terminals wire-ready for easy connection to SLC loop (accepts up to 12 AWG/3.25 mm² wire).
- Can be surface mounted (with SB-10 or SB-I/O) or semi-flush mounted. Semi-flush mount to a standard single-gang, double-gang, or 4" (10.16 cm) square electrical box.
- Smooth dual-action design.
- Meets ADAAG controls and operating mechanisms guidelines (Section 4.1.3[13]); meets ADA requirement for 5 lb. maximum activation force.
- Highly visible.
- Attractive shape and textured finish.
- Key reset.
- Includes Braille text on station handle.
- Optional trim ring (BG12TR).
- Meets UL 38, Standard for Manually Actuated Signaling Boxes.
- Up to 99 NBG-12LX stations per loop on CLIP protocol loops.
- Up to 159 NBG-12LX stations per loop on FlashScan® protocol loops.
- Dual-color LED blinks green to indicate normal on FlashScan® systems.

Construction

Shell, door, and handle are molded of durable polycarbonate material with a textured finish.

Specifications

- **Shipping Weight:** 9.6 oz. (272.15 g)
- **Normal operating voltage:** 24 VDC.
- **Maximum SLC loop voltage:** 28.0 VDC.
- **Maximum SLC standby current:** 375 µA.
- **Maximum SLC alarm current:** 5 mA.
- **Temperature Range:** 32°F to 120°F (0°C to 49°C)
- **Relative Humidity:** 10% to 93% (noncondensing)
- **For use indoors in a dry location**



The NBG-12LX
Addressable Manual Pull Station

Installation

The NBG-12LX will mount semi-flush into a single-gang, double-gang, or standard 4" (10.16 cm) square electrical outlet box, or will surface mount to the model SB-10 or SB-I/O surface backbox. If the NBG-12LX is being semi-flush mounted, then the optional trim ring (BG12TR) may be used. The BG12TR is usually needed for semi-flush mounting with 4" (10.16 cm) or double-gang boxes (not with single-gang boxes).

Operation

Pushing in, then pulling down on the handle causes it to latch in the down/activated position. Once latched, the word “ACTIVATED” (in bright yellow) appears at the top of the handle, while a portion of the handle protrudes from the bottom of the station. To reset the station, simply unlock the station with the key and pull the door open. This action resets the handle; closing the door automatically resets the switch.

Each manual station, on command from the control panel, sends data to the panel representing the state of the manual switch. Two rotary decimal switches allow address settings (1 – 159 on FlashScan® systems, 1 – 99 on CLIP systems).

Architectural/Engineering Specifications

Manual Fire Alarm Stations shall be non-coded, with a key-operated reset lock in order that they may be tested, and so designed that after actual Emergency Operation, they cannot be restored to normal except by use of a key. An operated station shall automatically condition itself so as to be visually detected as activated. Manual stations shall be constructed of red-colored polycarbonate material with clearly visible operating instructions provided on the cover. The word FIRE shall appear on the front of the stations in white letters, 1.00 inches (2.54 cm) or larger. Stations shall be suitable for surface mounting on matching backbox SB-10 or SB-I/O; or semi-flush mounting on a standard single-gang, double-gang, or

4" (10.16 cm) square electrical box, and shall be installed within the limits defined by the Americans with Disabilities Act (ADA) or per national/local requirements. Manual Stations shall be Underwriters Laboratories listed.

Manual stations shall connect with two wires to one of the control panel SLC loops. The manual station shall, on command from the control panel, send data to the panel representing the state of the manual switch. Manual stations shall provide address setting by use of rotary decimal switches.

The loop poll LED shall be clearly visible through the front of the station. The LED shall flash while in the normal condition, and stay steadily illuminated when in alarm.

Product Line Information

NBG-12LX: Dual-action addressable pull station. Includes key locking feature. (Listed for Canadian and non-Canadian applications.)

NBG-12LXSP: Spanish/English labelled version.

NBG-12LXP: Portuguese labelled version.

SB-10: Surface backbox; metal.

SB-I/O: Surface backbox; plastic.

BG12TR: Optional trim ring.

17021: Keys, set of two.

NY-Plate: New York City trim plate.

Agency Listings and Approvals

In some cases, certain modules or applications may not be listed by certain approval agencies, or listing may be in process. Consult factory for latest listing status.

- **UL/ULC Listed:** S692 (listed for Canadian and non-Canadian applications).
- **MEA:** 67-02-E.
- **CSFM:** 7150-0028:0199.
- **FDNY:** COA #6085 (NFS2-640), COA #6098 (NFS2-3030).
- **BSMI:** CI313066760047.
- **U.S. Coast Guard.**
- **Lloyd's Register.**
- **FM Approved.**

Patented: U.S. Patent No. D428,351; 6,380,846; 6,314,772; 6,632,108.

NOTIFIER® and FlashScan® are registered trademarks of Honeywell International Inc.

©2012 by Honeywell International Inc. All rights reserved. Unauthorized use of this document is strictly prohibited.



This document is not intended to be used for installation purposes.
We try to keep our product information up-to-date and accurate.
We cannot cover all specific applications or anticipate all requirements.
All specifications are subject to change without notice.



Made in the U.S. A.

For more information, contact Notifier. Phone: (203) 484-7161, FAX: (203) 484-7118.
www.notifier.com

FSP-851(A) Series

Intelligent Plug-In Photoelectric Smoke Detectors with FlashScan®



Intelligent/Addressable Devices

General

Notifier FSP-851(A) Series intelligent plug-in smoke detectors with integral communication provide features that surpass conventional detectors. Detector sensitivity can be programmed in the control panel software. Sensitivity is continuously monitored and reported to the panel. Point ID capability allows each detector's address to be set with rotary, decimal address switches, providing exact detector location for selective maintenance when chamber contamination reaches an unacceptable level. The FSP-851(A) photoelectric detector's unique optical sensing chamber is engineered to sense smoke produced by a wide range of combustion sources. Dual electronic thermistors add 135°F (57°C) fixed-temperature thermal sensing on the FSP-851T(A). The FSP-851R(A) is a remote test capable detector for use with DNR(A)/DNRW duct detector housings. FSP-851(A) series detectors are compatible with Notifier Onyx and CLIP series Fire Alarm Control Panels (FACPs).

FlashScan® (U.S. Patent 5,539,389) is a communication protocol developed by Notifier that greatly increases the speed of communication between analog intelligent devices. Intelligent devices communicate in a grouped fashion. If one of the devices in the group has new information, the panel's CPU stops the group poll and concentrates on single points. The net effect is response speed greater than five times that of earlier designs.

Features

- Sleek, low-profile design.
- Addressable-analog communication.
- Stable communication technique with noise immunity.
- Low standby current.
- Two-wire SLC connection.
- Compatible with FlashScan® and CLIP protocol systems.
- Rotary, decimal addressing (1-99 on CLIP systems, 1-159 on FlashScan systems).
- Optional remote, single-gang LED accessory.
- Dual LED design provides 360° viewing angle.
- Visible bi-color LEDs blink green every time the detector is addressed, and illuminate steady red on alarm (*FlashScan systems only*).
- Remote test feature from the panel.
- Walk test with address display (an address on 121 will blink the detector LED: 12-[pause]-1 (*FlashScan systems only*)).
- Built-in functional test switch activated by external magnet.
- Built-in tamper-resistant feature.
- Sealed against back pressure.
- Constructed of off-white fire-resistant plastic, designed to commercial standards, and offers an attractive appearance.
- 94-5V plastic flammability rating.
- SEMS screws for wiring of the separate base.
- Optional relay, isolator, and sounder bases.

Specifications

Sensitivity: 0.5% to 2.35% per foot obscuration

Size: 2.1" (5.3 cm) high; base determines diameter.

- **B210LP(A):** 6.1" (15.5 cm) diameter.
- **B501(A):** 4.1" (10.4 cm) diameter.
- **B200S(A):** 6.875" (17.46 cm) diameter.



FSP-851(A) in B210LP(A) Base

B210-2951.jpg

- **B200SR(A):** 6.875" (17.46 cm) diameter.
- **B224RB(A):** 6.2" (15.748 cm) diameter.
- **B224BI(A):** 6.2" (15.748 cm) diameter.

Shipping Weight: 5.2oz. (147g).

Operating Temperature range: FSP-851(A), 0°C to 49°C (32°F to 120°F). FSP-851T(A), 0°C to 38°C (32°F to 100°F). Low temperature signal for FSP-851T(A) at 45°F +/- 10°F (7.22°C +/- 5.54°C). FSP-851R(A) installed in a DNR(A)/DNRW, -20°C to 70°C (-4°F to 158°F).

UL/ULC Listed Velocity Range: 0-4000 ft/min. (1219.2 m/min.), suitable for installation in ducts.

Relative Humidity: 10%-93% noncondensing.

Thermal Ratings: Fixed-temperature setpoint 135°F (57°C).

DETECTOR SPACING AND APPLICATIONS

Notifier recommends spacing detectors in compliance with NFPA 72. In low airflow applications with smooth ceiling, space detectors 30 feet (9.144m) for ceiling heights 10 feet (3.148m) and higher. For specific information regarding detector spacing, placement, and special applications refer to NFPA 72. *System Smoke Detector Application Guide*, document A05-1003, is available at systemsensor.com

ELECTRICAL SPECIFICATIONS

Voltage Range: 15-32 volts DC peak.

Standby Current (max. avg.): 300µA @ 24VDC (one communication every five seconds with LED enabled).

LED Current (max.): 6.5mA @ 24 VDC ("ON").

Installation

FSP-851(A) plug-in detectors use a separate base to simplify installation, service, and maintenance. A special tool allows maintenance personnel to plug in and remove detectors without using a ladder.

Mount base (all base types) on an electrical backbox which is at least 1.5" (3.81 cm) deep. For a chart of compatible junction boxes, see DN-60054.

NOTE: 1) Because of inherent supervision provided by the SLC loop, end-of-line resistors are not required. Wiring "T-taps" or branches are permitted for Style 4 (Class "B") wiring. 2) When using relay or sounder bases, consult the ISO-X(A) installation

sheet 156-1380 for device limitations between isolator modules and isolator bases.

Agency Listings and Approvals

These listings and approvals apply to the modules specified in this document. In some cases, certain modules or applications may not be listed by certain approval agencies, or listing may be in process. *Consult factory for latest listing status.*

- **UL Listed:** S1115.
- **ULC Listed:** S1115 (FSP-851A, FSP-851RA, FSP-851TA).
- **MEA Listed:** 225-02-E .
- **FM Approved.**
- **CSFM:** 7272-0028:0206 .
- **Maryland State Fire Marshal:** Permit # 2122 .
- **BSMI:** CI313066760036.
- **CCCF:** Certif. # 2004081801000017 (FSP-851T)
Certif. # 2004081801000016 (FSP-851).
- **U.S. Coast Guard:** 161.002/42/1 (NFS-640); 161.002/50/0 (NFS2-640/NFS-320/NFS-320C, excluding B210LP(A)).
- **Lloyd's Register:** 11/600013 (NFS2-640/NFS-320/NFS-320C, excluding B210LP(A)).

Product Line Information

NOTE: "A" suffix indicates ULC Listed model.

FSP-851: Low-profile intelligent photoelectric sensor. Must be mounted to one of the bases listed below.

FSP-851A: Same as FSP-851 but with ULC listing.

FSP-851T: Same as FSP-851 but includes a built-in 135°F (57°C) fixed-temperature thermal device.

FSP-851TA: Same as FSP-851T but with ULC listing.

FSP-851R: Low-profile intelligent photoelectric sensor, remote test capable. For use with DNRA/DNRW.

FSP-851RA: Same as FSP-851R but with ULC listing. For use with DNRA.

INTELLIGENT BASES

NOTE: "A" suffix indicates ULC Listed model.

NOTE: For details on intelligent bases, see DN-60054.

B210LP(A): Standard U.S. flanged low-profile mounting base.

B210LPBP: Bulk pack of B210LP; package contains 10.

B501(A): Standard European flangeless mounting base.

B501BP: Bulk pack of B501; package contains 10.

B200S(A): Intelligent, programmable sounder base capable of producing sound output in high or low volume with ANSI Temporal 3, ANSI Temporal 4, continuous tone, marching tone, and custom tone.

B200SR(A): Intelligent sounder base capable of producing sound output with ANSI Temporal 3 or continuous tone. Replaces B501BH series bases in retrofit applications.

B224RB(A): Plug-in System Sensor **relay** base. Screw terminals: up to 14 AWG (2.0 mm²). Relay type: Form-C. Rating: 2.0 A @ 30 VDC resistive; 0.3 A @ 110 VDC inductive; 1.0 A @ 30 VDC inductive.

B224BI(A): Plug-in System Sensor **isolator** detector base. Maximum 25 devices between isolator bases .

ACCESSORIES

F110: Retrofit flange to convert B210LP(A) to match the B710LP(A) profile, or to convert older high-profile bases to low-profile.

F110BP: Bulk pack of F110; package contains 15.

F210: Replacement flange for B210LP(A) base.

RA100Z(A): Remote LED annunciator. 3 – 32 VDC. Mounts to a U.S. single-gang electrical box. For use with B501(A) and B210LP(A) bases only.

SMB600: Surface mounting kit

M02-04-00: Test magnet.

M02-09-00: Test magnet with telescoping handle.

XR2B: Detector removal tool. Allows installation and/or removal of detector heads from bases in high ceiling applications.

XP-4: Extension pole for XR2B. Comes in three 5-foot (1.524 m) sections.

T55-127-010: Detector removal tool without pole.

BCK-200B: Black detector covers for use with FSP-851(A) only; box of 10.

WCK-200B: White detector covers for use with FSP-851(A) only; box of 10.

-Notifier® and FlashScan® are registered trademarks of Honeywell International Inc.

©2011 by Honeywell International Inc. All rights reserved. Unauthorized use of this document is strictly prohibited.



This document is not intended to be used for installation purposes.
We try to keep our product information up-to-date and accurate.
We cannot cover all specific applications or anticipate all requirements.
All specifications are subject to change without notice.



Made in the U.S. A.

For more information, contact Notifier. Phone: (203) 484-7161, FAX: (203) 484-7118.
www.notifier.com

FST-851(A) Series

Intelligent Thermal (Heat) Detectors with FlashScan®



Intelligent / Addressable Devices

General

Notifier FST-851(A) Series intelligent plug-in thermal detectors with integral communication has features that surpass conventional detectors. Point ID capability allows each detector's address to be set with rotary, decimal address switches, providing exact detector locations. FST-851(A) Series thermal detectors use an innovative thermistor sensing circuit to produce 135°F/57°C fixed-temperature (FST-851/A) and rate-of-rise thermal detection (FST-851R/A) in a low-profile package. FST-851H(A) provides fixed high-temperature detection at 190°F/88°C. These thermal detectors provide effective, intelligent property protection in a variety of applications. FST-851(A) Series detectors are compatible with Notifier Onyx and CLIP series Fire Alarm Control Panels (FACPs).

FlashScan® (U.S. Patent 5,539,389) is a communication protocol developed by Notifier Engineering that greatly enhances the speed of communication between analog intelligent devices and certain NOTIFIER systems. Intelligent devices communicate in a grouped fashion. If one of the devices within the group has new information, the panel's CPU stops the group poll and concentrates on single points. The net effect is response speed greater than five times that of earlier designs.

Features

- Sleek, low-profile, stylish design.
- State-of-the-art thermistor technology for fast response.
- Rate-of-rise model (FST-851R/A), 15°F (8.3°C) per minute.
- Factory preset fixed temperature at 135°F (57°C); high-temperature model fixed at 190°F (88°C).
- Addressable by device.
- Compatible with FlashScan® and CLIP protocol systems.
- Rotary, decimal addressing (1-99 on CLIP systems, 1-159 on FlashScan systems).
- Two-wire SLC connection.
- Visible LEDs "blink" every time the unit is addressed.
- 360°-field viewing angle of the visual alarm indicators (two bi-color LEDs). LEDs blink green in Normal condition and turn on steady red in Alarm.
- Integral communications and built-in device-type identification.
- Remote test feature from the panel.
- Built-in functional test switch activated by external magnet.
- Walk test with address display (an address of 121 will blink the detector LED 12-(pause)-1).
- Low standby current.
- Backward-compatible.
- Built-in tamper-resistant feature.
- Designed for direct-surface or electrical-box mounting.
- Sealed against back pressure.
- Plugs into separate base for ease of installation and maintenance. Separate base allows interchange of photoelectric, ionization and thermal sensors.
- SEMS screws for wiring of the separate base.
- Constructed of off-white fire-resistant plastic, designed to commercial standards, and offers an attractive appearance.



FST-851(A) in B210LP(A) Base

B210-2251.jpg

- 94-5V plastic flammability rating.
- Remote LED output connection to optional RA100Z(A) remote LED annunciator.
- Optional sounder, relay, and isolator bases.
- Optional flanged surface mounting kit.

Specifications

Size: 2.1" (5.3 cm) high; base determines diameter.

- **B210LP(A):** 6.1" (15.5 cm) diameter.
- **B501(A):** 4.1" (10.4 cm) diameter.
- **B200S(A):** 6.875" (17.46 cm) diameter.
- **B200SR(A):** 6.875" (17.46 cm) diameter.
- **B224RB(A):** 6.2" (15.748 cm) diameter.
- **B224BI(A):** 6.2" (15.748 cm) diameter.

Shipping weight: 4.8 oz. (137 g).

Operating temperature range: FST-851(A) Series, FST-851R(A): -20°C to 38°C (-4°F to 100°F); FST-851H(A): -20°C to 66°C (-4°F to 150°F).

Detector spacing: UL approved for 50 ft. (15.24 m) center to center. FM approved for 25 x 25 ft. (7.62 x 7.62 m) spacing.

Relative humidity: 10% – 93% noncondensing.

Thermal ratings: fixed-temperature setpoint 135°F (57°C), rate-of-rise detection 15°F (8.3°C) per minute, high temperature heat 190°F (88°C).

ELECTRICAL SPECIFICATIONS

Voltage range: 15 - 32 volts DC peak.

Standby current (max. avg.): 300 µA @ 24 VDC (one communication every 5 seconds with LED enabled).

LED current (max.): 6.5 mA @ 24 VDC ("ON").

Applications

Use thermal detectors for protection of property. For further information, go to systemsensor.com for manual I56-407-00, Applications Manual for System Smoke Detectors, which provides detailed information on detector spacing, placement, zoning, wiring, and special applications.

Installation

The FST Series plug-in intelligent thermal detectors use a separate base to simplify installation, service, and maintenance. Installation instructions are shipped with each detector. A special tool allows maintenance personnel to plug in and remove detectors without using a ladder.

Mount base (all base types) on an electrical backbox which is at least 1.5" (3.81 cm) deep. For a chart of compatible junction boxes, see *DN-60054*.

NOTE: 1) Because of the inherent supervision provided by the SLC loop, end-of-line resistors are not required. Wiring "T-taps" or branches are permitted for Style 4 (Class "B") wiring. **2)** When using relay or sounder bases, consult the ISO-X(A) installation sheet 156-1380 for device limitations between isolator modules and isolator bases.

Agency Listings and Approvals

These listings and approvals apply to the modules specified in this document. In some cases, certain modules or applications may not be listed by certain approval agencies, or listing may be in process. Consult factory for latest listing status.

- **UL Listed:** S747.
- **ULC Listed:** S6978.
- **MEA Listed:** 383-02-E.
- **FM Approved.**
- **CSFM:** 7270-0028:0196.
- **BSMI:** CI313066760025.
- **CCCF:** Certif. # 2004081801000018.
- **U.S. Coast Guard:** 161.002/42/1 (NFS-640); 161.002/50/0 (NFS2-640/NFS-320/NFS-320C, excluding B210LP(A)).
- **Lloyd's Register:** 11/600013 (NFS-640/NFS-320/NFS-320C, excluding B210LP(A)).

Product Line Information

NOTE: "A" suffix indicates ULC Listed model.

FST-851: Intelligent thermal detector. Must be mounted to one of the bases listed below.

FST-851A: Same as FST-851 but with ULC Listing.

FST-851R: Intelligent thermal detector with rate-of-rise feature.

FST-851RA: Same as FST-851R but with ULC Listing.

FST-851H: Intelligent high-temperature thermal detector.

FST-851HA: Same as FST-851H but with ULC Listing.

INTELLIGENT BASES

NOTE: "A" suffix indicates ULC Listed model.

NOTE: For details about intelligent bases and their mounting, see *DN-60054*.

B210LP(A): Standard U.S. flanged low-profile mounting base.

B210LPBP: Bulk pack of B210LP; package contains 10.

B501(A): Standard European flangeless mounting base.

B501BP: Bulk pack of B501; package contains 10.

B200S(A): Addressable Intelligent, programmable sounder base capable of producing sound output in high or low volume

with ANSI Temporal 3, ANSI Temporal 4, continuous tone, marching tone, and custom tone.

B200SR(A): Intelligent sounder base capable of producing sound output with ANSI Temporal 3 or continuous tone. Replaces B501BH series bases in retrofit applications.

B224RB(A): Intelligent relay base. Screw terminals: up to 14 AWG (2.0 mm²). Relay type: Form-C. Rating: 2.0 A @ 30 VDC resistive; 0.3 A @ 110 VDC inductive; 1.0 A @ 30 VDC inductive.

B224BI(A): Intelligent isolator base. Isolates SLC from loop shorts. Maximum: 25 devices between isolator bases; see Note 2 under Installation.

ACCESSORIES

F110: Retrofit flange to convert B210LP(A) to match the B710LP(A) profile, or to convert older high-profile bases to low-profile.

F110BP: Bulk pack of F110; package contains 15.

F210: Replacement flange for B210LP(A) base.

RA100Z(A): Remote LED annunciator. 3 – 32 VDC. Fits U.S. single-gang electrical box. Supported by B210LP(A) and B501(A) bases only.

SMB600: Surface mounting kit, flanged.

M02-04-00: Test magnet.

M02-09-00: Test magnet with telescoping handle.

XR2B: Detector removal tool. Allows installation and/or removal of FlashScan® Series detector heads from base in high ceiling installations. Includes T55-127-010.

T55-127-010: Detector removal tool without pole.

XP-4: Extension pole for XR2B. Comes in three 5-foot (1.524 m) sections.

Notifier® and FlashScan® are registered trademarks of Honeywell International Inc.

©2011 by Honeywell International Inc. All rights reserved. Unauthorized use of this document is strictly prohibited.



This document is not intended to be used for installation purposes.
We try to keep our product information up-to-date and accurate.
We cannot cover all specific applications or anticipate all requirements.
All specifications are subject to change without notice.



For more information, contact Notifier. Phone: (203) 484-7161, FAX: (203) 484-7118.
www.notifier.com

DNR(A)/DNRW InnovairFlex

Intelligent Non-Relay Photoelectric Duct Smoke Detector



Intelligent Devices

General

The Notifier InnovairFlex® DNR(A) intelligent non-relay photoelectric duct smoke detector and DNRW watertight non-relay photoelectric duct smoke detector feature a pivoting housing that fits both square and rectangular footprints capable of mounting to a round or rectangular duct.

DNRW duct smoke detector, with its NEMA-4 rating, is listed as a watertight, UV resistant enclosure providing protection against falling dirt, rain, and windblown dust, splashing and hose directed water, allowing operators to use the detector in the most extreme environments.

These units sense smoke in the most challenging conditions, operating in airflow speeds of 100 to 4,000 feet per minute (0.5 to 20.32 m/s), temperatures of -4°F to 158°F (-20°C to 70°C), and a humidity range of 0 to 95 percent (non-condensing.)

An improved cover design isolates the sensor head, which allows for ease of maintenance. A cover tamper feature indicates a trouble signal for a removed or improperly installed sensor cover. The Notifier InnovairFlex housing provides a 3/4-inch conduit knockout and ample space to facilitate easy wiring and mounting of a relay module.

The Notifier InnovairFlex duct smoke detector can be customized to meet local codes and specifications without additional wiring. The new InnovairFlex product line is compatible with all previous Innovair models, including remote test accessories.

Features

- Photoelectric, integrated low-flow technology.
- Air velocity rating from 100 ft/min to 4,000 ft/min (0.5 m/s to 20.32 m/s).
- Versatile mounting options: square or rectangular configuration.
- Broad ranges for operating temperature (-4°F to 158°F, -20°C to 70°C) and humidity (0% to 95% non-condensing).
- Patented sampling tube installs from front or back of the detector with no tools required.
- Cover tamper signal.
- Increased wiring space with a newly added 3/4" conduit knockout.
- Available space within housing to accommodate mounting of a relay module.
- Easily accessible code wheels on sensor head (sold separately).
- Clear cover for convenient visual inspection.
- Remote testing capability.
- Requires com line power only.
- Accommodates the installation of an addressable relay module, sold separately, (FRM-1 or NC-100R) for applications requiring a Form-C relay.

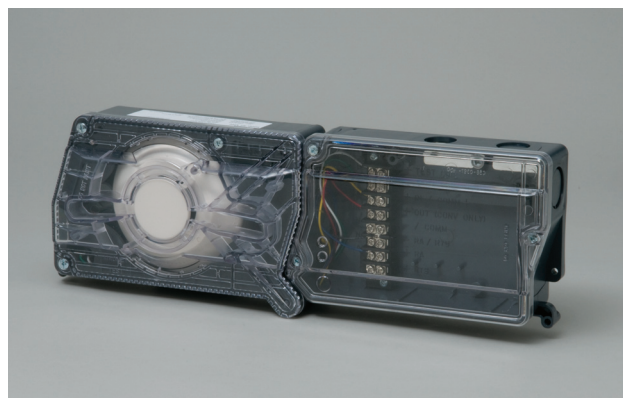

Specifications

Size: (Rectangle) 14.38 in (37 cm) Length; 5 in (12.7 cm) Width, 2.5 in (6.6 cm) Depth.

Size: (Square) 7.75 in (19.7 cm) Length; 9 in (22.9 cm) Width; 2.5 in (6.35 cm) Depth.

Weight: 1.6 lb (0.73 kg).

Operating Temperature Range: -4°F to 158°F (-20°C to 70°C).

Storage Temperature Range: -22°F to 158°F (-30°C to 70°C).

Operating Humidity Range: 0% to 95% relative humidity (non-condensing).

Air Duct Velocity: 100 to 4,000 ft/min (0.5 to 20.32 m/s).

Accessories

Notifier provides system flexibility with a variety of accessories, including two remote test stations and different means of visible and audible system annunciation. As with our duct smoke detectors, all duct smoke detectors accessories are UL listed.

DNR(W)s with a date code of 0013 or higher do not require external 24VDC for remote test applications when used with a remote-test-capable detector.

ACCESSORY CURRENT LOADS AT 24 VDC

Device	Standby	Alarm
RA100Z	0mA	12 mA Max
RTS151/ RTS151KEY	0mA	12mA Max

Agency Listings and Approvals

Consult product manual for lists of compatible UL-Listed devices. In some cases, certain modules may not be listed by certain approval agencies, or listing may be in process. Consult factory for latest listing status.

- **UL:** S911, S3705.
- **ULC:** S635.

- **CSFM:** 3242-1653:0209.
- **FM approved.**

Product Line Information

NOTE: "A suffix indicates ULC listed model.

DNR(A): Intelligent non-relay photoelectric low flow smoke detector housing. Requires photoelectric smoke detector (sold separately).

DNRW: Watertight intelligent non-relay photoelectric low flow duct smoke detector housing. Requires photoelectric smoke detector (sold separately).

FSP-851R(A): Remote test capable addressable low-profile photoelectric smoke detector.

FSP-851(A): Addressable low-profile photoelectric smoke detector.

NP-100: Addressable low-profile photoelectric smoke detector for FireWarden series panels.

NP-100R(A): Remote test capable addressable low-profile photoelectric smoke detector for FireWarden series panels.

DCOIL: Remote test coil. Required for older DNR(W) duct detector housing.

DST1(A): Metal sampling tube duct width up to 1 ft (0.3m).

DST1.5(A): Metal sampling tube duct widths up to 1 ft to 2 ft (0.3 to 0.6 m).

DST3(A): Metal sampling tube duct widths up to 2 ft to 4 ft (0.6 to 1.2 m).

DST5(A): Metal sampling tube duct widths up to 4 ft to 8 ft (1.2 to 2.4 m).

DST10(A): Metal sampling tube duct widths up to 8 ft to 12 ft (2.4 to 3.7 m).

DH400OE-1: Weatherproof enclosure.

ETX: Metal exhaust tube duct, width 1 ft (0.3 m).

M02-04-00: Test magnet.

P48-21-00: End cap for metal sampling tubes.

RA100Z(A): Remote annunciator alarm LED.

RTS151(A): Remote test station.

RTS151KEY(A): Remote test station with key lock.

Important Note

- DNRW duct detector housings with a date code of 0013 or higher do not require a DCOIL or auxiliary 24 VDC for remote test applications when used with a remote test capable detector.
- DNRW duct detector housings with a date code of 0012 or earlier require a DCOIL and auxiliary 24 VDC power for remote test applications.

Notifier® and FlashScan® are a registered trademark of Honeywell International Inc.

©2012 by Honeywell International Inc. All rights reserved. Unauthorized use of this document is strictly prohibited.



This document is not intended to be used for installation purposes.
We try to keep our product information up-to-date and accurate.
We cannot cover all specific applications or anticipate all requirements.
All specifications are subject to change without notice.



For more information, contact Notifier. Phone: (203) 484-7161, FAX: (203) 484-7118.
www.notifier.com

B210LP Plug-in Detector Base

SPECIFICATIONS

Base Diameter:	6.1 inches (155 mm)
Base Height:	.76 inches (19 mm)
Operating Temperature:	Refer to applicable sensor Operating Temperature Range using the Base/Sensor Cross Reference Chart at systemsensor.com
Electrical Ratings:	
Operating Voltage:	15 to 32 VDC
Standby Current:	170 μ A

BEFORE INSTALLING

Please read the *System Smoke Detectors Application Guide*, which provides detailed information on detector spacing, placement, zoning, wiring, and special applications. Copies of this application guide are available from System Sensor. NFPA 72 guidelines should be observed.

NOTICE: This manual should be left with the owner/user of this equipment.

IMPORTANT: The detector used with this base must be tested and maintained regularly following NFPA 72 requirements. The detector should be cleaned at least once a year.

GENERAL DESCRIPTION

The B210LP is a plug-in detector base intended for use in an intelligent system, with screw terminals provided for power (+ and -), and remote annunciator connections. Communication takes place over the power (+ and -) lines.

BASE TERMINALS

NO.	FUNCTION
1	Power (-), Remote Annunciator (-)
2	Power (+)
3	Remote Annunciator (+)

FIGURE 1. TERMINAL LAYOUT:

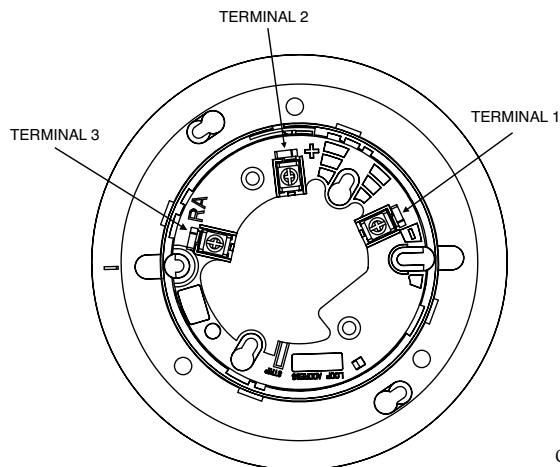

C0127-07

MOUNTING

This detector base mounts directly to 4-inch square (with and without plaster rings), 4-inch octagon, 3 1/2-inch octagon, and single gang junction boxes. To mount, remove the decorative ring by turning it in either direction to unhook the snaps, then separate the ring from the base. Install the base on the box using the screws supplied with the junction box and the appropriate mounting slots in the base.

Place the decorative ring on the base and rotate it in either direction until it snaps into place (see Figure 2).

FIGURE 2. MOUNTING DETECTOR TO BOX:

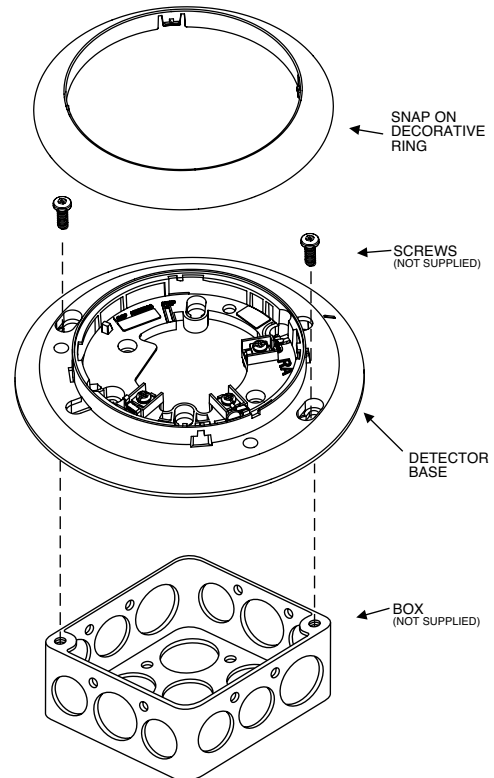

C0128-06

INSTALLATION AND WIRING GUIDELINES (SEE FIGURE 3)

All wiring must be installed in compliance with all applicable local codes and any special requirements of the authority having jurisdiction. Proper wire gauges should be used. The conductors used to connect smoke detectors to control panels and accessory devices should be color-coded to reduce the likelihood of wiring errors. Improper connections can prevent a system from responding properly in the event of a fire.

For signal wiring (the wiring between interconnected detectors), it is recommended that the wire be no smaller than 18 AWG (0.823 square mm). Wire sizes up to 12 AWG (3.31 square mm) may be used with the base.

Make electrical connections by stripping about 3/8 inch (10 mm) of insulation from the end of the wire (use strip gauge molded in base). Then slide the wire under the clamping plate and tighten the clamping plate screw. Do not loop the wire under the clamping plate. (See Figure 4)

Check the zone wiring of all bases in the system before installing the detectors. This includes checking the wiring for continuity, correct polarity, ground fault testing and performing a dielectric test.

The base includes an area for recording the zone, address, and type of detector being installed. This information is useful for setting the detector head address and for verification of the detector type required for that location.

Once all detector bases have been wired and mounted, and the loop wiring has been checked, the detector heads may be installed in the bases.

FIGURE 3. TYPICAL WIRING DIAGRAM FOR 2-WIRE LOOP:

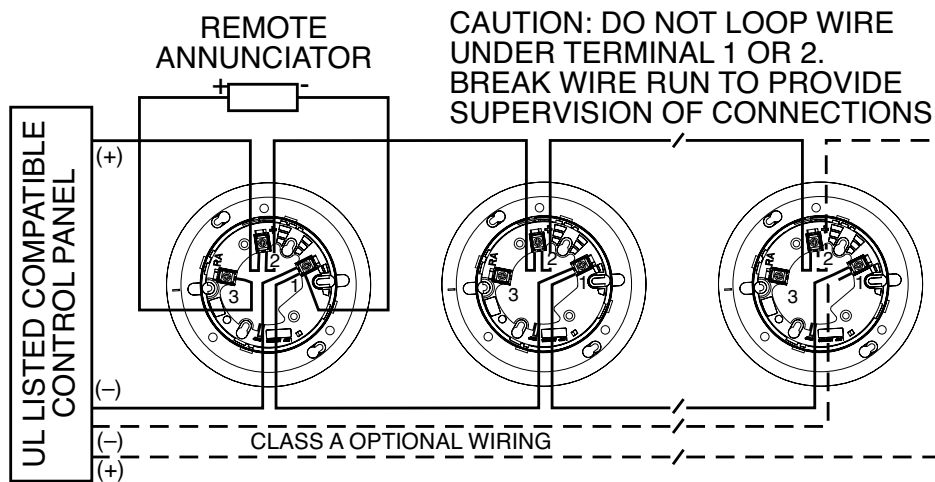

C0129-02

FIGURE 4.:

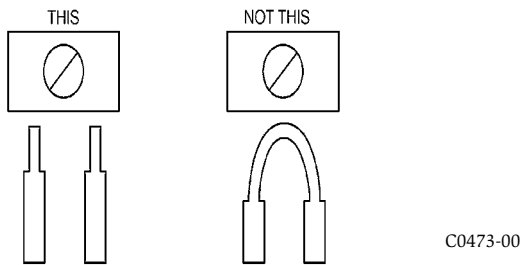

TAMPER-RESIST FEATURE

NOTE: Do not use the tamper-resist feature if the removal tool will be used.

The detector base includes a tamper-resist feature that prevents removal of the detector without using a small screwdriver or similar tool.

To activate this feature, use needle-nose pliers to break the tab on the detector base as shown in Figure 5A. Then, install the detector.

To remove the detector from the base once the tamper-resist feature has been activated, remove the decorative ring by rotating it in either direction and pulling it away from the base. Then, insert a small screwdriver into the notch, as indicated in Figure 5B, and press the plastic lever toward the mounting surface before rotating the detector counterclockwise for removal.

The tamper-resist feature can be defeated by breaking and removing the plastic lever from the base. However, this prevents the feature from being used again.

REMOTE ANNUNCIATOR (RA100Z)

Connect the remote annunciator between terminals 1 and 3 using the spade lug terminal included. The spade lug terminal is connected to the base terminal as shown in Figure 6.

It is not acceptable to have three stripped wires under the same wiring terminal unless they are separated by a washer or equivalent means. The spade lug supplied with the model RA100Z is considered an equivalent means. See Figure 3 for proper installation.

FIGURE 5A. ENABLING THE TAMPER-RESISTANT CAPABILITY:

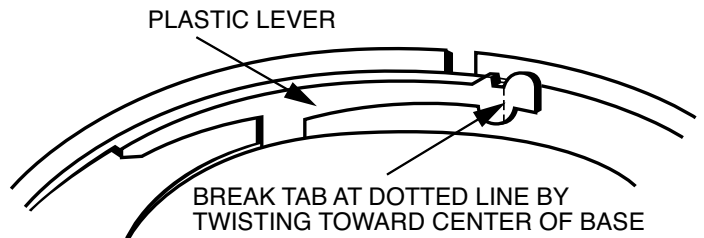

C0130-00

FIGURE 5B. REMOVING THE DETECTOR HEAD FROM THE BASE:

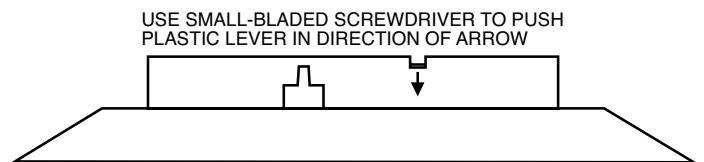

C0130-00

FIGURE 6. CONNECTION TO REMOTE ANNUNCIATOR TERMINAL:

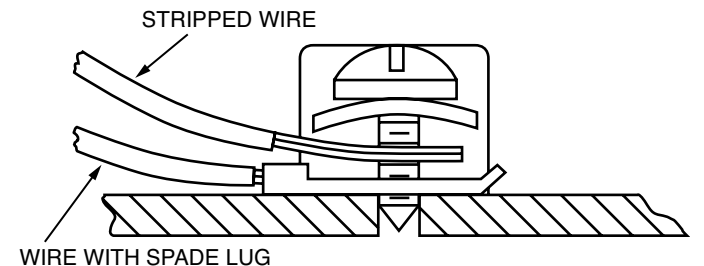

C0116-00

Please refer to insert for the Limitations of Fire Alarm Systems

THREE-YEAR LIMITED WARRANTY

System Sensor warrants its enclosed smoke detector base to be free from defects in materials and workmanship under normal use and service for a period of three years from date of manufacture. System Sensor makes no other express warranty for this smoke detector base. No agent, representative, dealer, or employee of the Company has the authority to increase or alter the obligations or limitations of this Warranty. The Company's obligation of this Warranty shall be limited to the repair or replacement of any part of the smoke detector base which is found to be defective in materials or workmanship under normal use and service during the three year period commencing with the date of manufacture. After phoning System Sensor's toll free number 800-SENSOR2 (736-7672) for a Return Authorization number, send defective units postage prepaid to: System Sensor,

Repair Department, RA # _____, 3825 Ohio Avenue, St. Charles, IL 60174. Please include a note describing the malfunction and suspected cause of failure. The Company shall not be obligated to repair or replace units which are found to be defective because of damage, unreasonable use, modifications, or alterations occurring after the date of manufacture. In no case shall the Company be liable for any consequential or incidental damages for breach of this or any other Warranty, expressed or implied whatsoever, even if the loss or damage is caused by the Company's negligence or fault. Some states do not allow the exclusion or limitation of incidental or consequential damages, so the above limitation or exclusion may not apply to you. This Warranty gives you specific legal rights, and you may also have other rights which vary from state to state.

Duct Smoke Detector Accessories

for Notifier/System Sensor Products



Miscellaneous

General

Duct smoke detector accessories add functionality to the duct smoke system by allowing quick, convenient inspections at eye level and effective audible and visual notification options. All System Sensor duct smoke detectors and accessories are UL listed.

Specifications

APA151 PIEZO ANNUNCIATOR

The **APA151** piezo annunciator, which replaces the APA451 with a new, improved look, provides an audible alarm signal, a red LED to indicate alarm status, and a green LED to indicate power status. It is intended for use with System Sensor 4-wire conventional duct smoke detector applications without a system control panel, to comply with NFPA 90A.



APA151.wmf

APA151 Piezo Annunciator	
Voltage	Regulated 24 VDC
Operating Voltage	16 to 33 VDC
Maximum Alarm Current	30 mA
Temperature Range	32°F to 120°F (0°C to 49°C)
Relative Humidity	10 to 93%, non-condensing
Wire Gauge	12 to 18 AWG
Dimensions	4.6" H x 2.9" W x .45" D

MHR/MHW MINI-HORNS

The **MHR** and **MHW** SpectrAlert® Advance mini-horns feature temporal or continuous tones at high and low volume settings. Their small footprint allows mounting to single-gang back boxes for applications where a small device is desired.



MHR.wmf, MHW.wmf



60535cov.wmf

MHR/MHW SpectrAlert Advance Mini-Horns	
Voltage	Regulated 12 DC or FWR (Full Wave Rectified) or Regulated 24 VDC or FWR
Operating Voltage	8 to 33 VDC (9 to 33 VDC with Sync-Circuit™ Module)
Sounder Current Draw	22 mA RMS max. at 8 to 17.5 Volts DC 17 mA RMS max. at 8 to 17.5 Volts FWR 29 mA RMS max. at 16 to 33 Volts DC 25 mA RMS max. at 16 to 33 Volts FWR
Temperature Range	32°F to 120°F (0°C to 49°C)
Humidity Range	10 to 93% non-condensing
Nominal Sounder Frequency	3 kHz
Wire Gauge	12 to 18 AWG
Dimensions	4.6"H x 2.9"W x 0.45"D

RA100Z/RA100ZA REMOTE ANNUNCIATORS

The **RA100Z** and **RA100ZA** remote annunciators are designed for both conventional and intelligent applications. Their red LED provides visual indication of an alarm condition.



RA100Z.wmf

RA100Z/RA100ZA Remote Annunciator	
Voltage Range	Conventional System: 3.1 to 32 VDC Intelligent System: 18 to 32 VDC
Maximum Alarm Current	10 mA
Dimensions	4.6"H x 2.8"W x 1.3"D

RTS151/RTS151KEY REMOTE TEST STATIONS

The **RTS151** and **RTS151KEY** remote test stations are automatic fire detector accessories designed to test duct smoke detectors from a convenient location. For 4-wire detectors, the **RTS151KEY** test station features a multi-colored LED that alternates between steady green and red. For 2-wire detectors, the LED illuminates red for alarm.



RTS151.wmf, RTS151KEY.wmf

RTS151 Remote Test Station	
Power Requirements	Alarm LED 2.8 to 32 VDC, 10 mA max. Total Current: 95 mA max.
Test Switch	10 VA @ 32 VDC
Reset Switch	10 VA @ 32 VDC
Alarm Response Time	40 seconds max.
Temperature Range	14°F to 140°F (-10°C to 60°C)
Relative Humidity	95% non-condensing
Wire Gauge	14 to 18 AWG
Dimensions	4.8"H x 2.9"W x 1.4"D

RTS151KEY Remote Test Station with Key

Power Requirements	Power LED (Green): 14 to 35 VDC, 12 mA max. Alarm LED (RED): 2.8 to 32 VDC, 12 mA max.
Alarm Response Time	40 seconds max.
Temperature Range	14°F to 140°F (-10°C to 60°C)
Relative Humidity	95% non-condensing
Wire Gauge	14 to 18 AWG
Dimensions	4.6"H x 2.75"W x 1.8"D

RTS2/RTS-AOS MULTI-SIGNALLING ACCESSORIES

The **RTS2** and **RTS2-AOS** multi-signaling accessories are designed to work with InnovairFlex 4-wire conventional duct smoke detectors. These accessories include a key switch that can be used to select one of two connected sensors to be tested, reset, or both by a push button switch. They also enable sensitivity measurements using the SENS-RDR sensitivity reader (sold separately). The **AOS** (Add-On Strobe) is an optional accessory included with the **RTS2-AOS** model.



RTS-AOS.wmf, AOS.wmf

RTS2 and RTS-AOS Multi-Signaling Accessory

Voltage	20 to 29 VDC
Power Requirements	Standby: 3.0 mA max. Trouble: 16.0 mA max. Alarm without Strobe: 30 mA max. Alarm with Strobe: 55 mA max.
Sounder	85 dBA at 10 ft.
Temperature Range	14°F to 140°F (-10°C to 60°C)
Relative Humidity	95% non-condensing
Wire Gauge	14 to 22 AWG
Dimensions	4.8"W x 5.3"H x 1.6"D

Product Line Information

APA151: Piezo Annunciator

MHR: Mini-Horn, Red

MHW: Mini-Horn, White

RA100Z/RA100ZA: Remote Annunciator

RTS151: Remote Test Station

RTS151KEY: Remote Test Station with Key

RTS2: Multi-signaling Accessory

AOS: Add-On Strobe

RTS2-AOS: Multi-Signaling Accessory

Temperature and Humidity Ranges

This system meets NFPA requirements for operation at 0 – 49°C/32 – 120°F and at a relative humidity 93% ± 2% RH (noncondensing) at 32°C ± 2°C (90°F ± 3°F). However, the useful life of the system's standby batteries and the electronic components may be adversely affected by extreme temperature ranges and humidity. Therefore, it is recommended that this system and its peripherals be installed in an environment with a normal room temperature of 15 – 27°C/60 – 80°F.

Agency Listings and Approvals

The listings and approvals below apply to the basic products. In some cases, certain modules may not be listed by certain approval agencies, or listing may be in process. Consult factory for latest listing status.

- **UL: S4011 (APA 151, MHR, MHW), S2522 (RTS2, RA100Z, RTS151, RTS151KEY, RTS2-AOS)**
- **FM Approved**
- **CSFM: 7135-1653:0212**

FlashScan®, **NOTIFIER®** and **System Sensor®** are registered trademarks of Honeywell International Inc.
©2012 by Honeywell International Inc. All rights reserved. Unauthorized use of this document is strictly prohibited.



This document is not intended to be used for installation purposes.
We try to keep our product information up-to-date and accurate.
We cannot cover all specific applications or anticipate all requirements.
All specifications are subject to change without notice.



Made in the U.S. A.

For more information, contact Notifier. Phone: (203) 484-7161, FAX: (203) 484-7118.
www.notifier.com

FCM-1(A) & FRM-1(A) Series

Control and Relay Modules



Intelligent / Addressable Devices

General

FCM-1(A) Control Module: The FCM-1(A) Addressable Control Module provides Notifier intelligent fire alarm control panels a circuit for Notification Appliances (horns, strobes, speakers, etc.). Addressability allows the FCM-1(A) to be activated, either manually or through panel programming, on a select (zone or area of coverage) basis.

FRM-1(A) Relay Module: The FRM-1(A) Addressable Relay Module provides the system with a dry-contact output for activating a variety of auxiliary devices, such as fans, dampers, control equipment, etc. Addressability allows the dry contact to be activated, either manually or through panel programming, on a select basis.

FlashScan® (U.S. Patent 5,539,389) is a communication protocol developed by NOTIFIER Engineering that greatly enhances the speed of communication between analog intelligent devices. Intelligent devices communicate in a grouped fashion. If one of the devices within the group has new information, the panel CPU stops the group poll and concentrates on single points. The net effect is response speed greater than five times that of other designs.

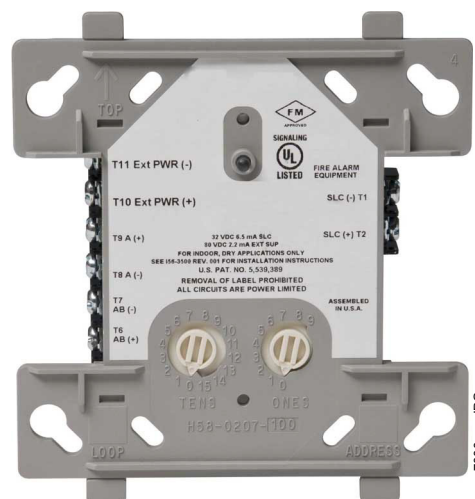

FCM-1(A)

Features

- Built-in type identification automatically identifies these devices to the control panel.
- Internal circuitry and relay powered directly by two-wire SLC loop. The FCM-1(A) module requires power (for horns, strobes, etc.), or audio (for speakers).
- Integral LED “blinks” green each time a communication is received from the control panel and turns on in steady red when activated.
- LED blink may be deselected globally (affects all devices).
- High noise immunity (EMF/RFI).
- The FCM-1(A) may be used to switch 24-volt NAC power, audio (up to 70.7 Vrms).
- Wide viewing angle of LED.
- SEMS screws with clamping plates for wiring ease.
- Direct-dial entry of address 01– 159 for FlashScan loops, 01 – 99 for CLIP mode loops.
- Speaker, and audible/visual applications may be wired for Class B or A (Style Y or Z).

Applications

The FCM-1(A) is used to switch 24 VDC audible/visual power, high-level audio (speakers). The FRM-1(A) may be programmed to operate dry contacts for applications such as door holders or Air Handling Unit shutdown, and to reset four-wire smoke detector power.

NOTE: Refer to the SLC Manual (PN 51253) for details regarding releasing applications with the FCM-1(A). Refer to the FCM-1-REL datasheet (DN-60390) for new FlashScan® releasing applications.

Construction

- The face plate is made of off-white heat-resistant plastic.
- Controls include two rotary switches for direct-dial entry of address (01-159).

- The FCM-1(A) is configured for a single Class B (Style Y) or Class A (Style Z) Notification Appliance Circuit.
- The FRM-1(A) provides two Form-C dry contacts that switch together.

Operation

Each FCM-1(A) or FRM-1(A) uses one of 159 possible module addresses on a SLC loop (99 on CLIP loops). It responds to regular polls from the control panel and reports its type and status, including the open/normal/short status of its Notification Appliance Circuit (NAC). The LED blinks with each poll received. On command, it activates its internal relay. The FCM-1(A) supervises Class B (Style Y) or Class A (Style Z) notification or control circuits.

Upon code command from the panel, the FCM-1(A) will disconnect the supervision and connect the external power supply in the proper polarity across the load device. The disconnection of the supervision provides a positive indication to the panel that the control relay actually turned ON. The external power supply is always relay isolated from the communication loop so that a trouble condition on the external power supply will never interfere with the rest of the system.

Rotary switches set a unique address for each module. The address may be set before or after mounting. The built-in TYPE CODE (not settable) will identify the module to the control panel, so as to differentiate between a module and a sensor address.

Specifications for FCM-1(A)

Normal operating voltage: 15 to 32 VDC.

Maximum current draw: 6.5 mA (LED on).

Average operating current: 350 μ A direct poll, 375 μ A group poll with LED flashing, 485 μ A Max. (LED flashing, NAC shorted.)

Maximum NAC Line Loss: 4 VDC.

External supply voltage (between Terminals T10 and T11): Maximum (NAC): Regulated 24 VDC; Maximum (Speakers): 70.7 V RMS, 50W.

Drain on external supply: 1.7 mA maximum using 24 VDC supply; 2.2 mA Maximum using 80 VRMS supply.

Max NAC Current Ratings: For class B wiring system, the current rating is 3A; For class A wiring system, the current rating is 2A.

Temperature range: 32°F to 120°F (0°C to 49°C).

Humidity range: 10% to 93% non-condensing.

Dimensions: 4.5" (114.3 mm) high x 4" (101.6 mm) wide x 1.25" (31.75 mm) deep. Mounts to a 4" (101.6 mm) square x 2.125" (53.975 mm) deep box.

Accessories: SMB500 Electrical Box; CB500 Barrier

Specifications for FRM-1(A)

Normal operating voltage: 15 to 32 VDC.

Maximum current draw: 6.5 mA (LED on).

Average operating current: 230 µA direct poll; 255 µA group poll.

EOL resistance: not used.

Temperature range: 32°F to 120°F (0°C to 49°C).

Humidity range: 10% to 93% non-condensing.

Dimensions: 4.5" (114.3 mm) high x 4" (101.6 mm) wide x 1.25" (31.75 mm) deep. Mounts to a 4" (101.6 mm) square x 2.125" (53.975 mm) deep box.

Accessories: SMB500 Electrical Box; CB500 Barrier

Agency Listings and Approvals

In some cases, certain modules may not be listed by certain approval agencies, or listing may be in process. Consult factory for latest listing status.

- **UL:** S635
- **ULC:** S3705 (A version only)
- **FM Approved**
- **CSFM:** 7300-0028:0219
- **MEA:** 14-00-E
- **FDNY:** COA #6067, #6065

Contact Ratings for FRM-1(A)

Current Rating	Maximum Voltage	Load Description	Application
3 A	30 VDC	Resistive	Non-Coded
2 A	30 VDC	Resistive	Coded
.9 A	110 VDC	Resistive	Non-Coded
.9 A	125 VDC	Resistive	Non-Coded
.5 A	30 VDC	Inductive (L/R=5ms)	Coded
1 A	30 VDC	Inductive (L/R=2ms)	Coded
.3 A	125 VAC	Inductive (PF=0.35)	Non-Coded
1.5 A	25 VAC	Inductive (PF=0.35)	Non-Coded
.7 A	70.7 VAC	Inductive (PF=0.35)	Non-Coded
2 A	25 VAC	Inductive (PF=0.35)	Non-Coded

NOTE: Maximum (Speakers): 70.7 V RMS, 50 W

Product Line Information

NOTE: "A" suffix indicates ULC Listed model.

FCM-1(A): Intelligent Addressable Control Module.

FRM-1(A): Intelligent Addressable Relay Module.

A2143-20: Capacitor, required for Class A (Style Z) operation of speakers.

SMB500: Optional Surface-Mount Backbox.

CB500: Control Module Barrier — required by UL for separating power-limited and non-power limited wiring in the same junction box as FCM-1(A).

NOTE: For installation instructions, see the following documents:

- *FCM-1(A) Installation document I56-1169.*
- *FRM-1(A) Installation document I56-3502.*
- *Notifier SLC Wiring Manual, document 51253.*

Notifier® and FlashScan® are registered trademarks of Honeywell International Inc.

©2011 by Honeywell International Inc. All rights reserved. Unauthorized use of this document is strictly prohibited.



This document is not intended to be used for installation purposes.
We try to keep our product information up-to-date and accurate.
We cannot cover all specific applications or anticipate all requirements.
All specifications are subject to change without notice.



Made in the U.S. A.

For more information, contact Notifier. Phone: (203) 484-7161, FAX: (203) 484-7118.
www.notifier.com

FMM-1(A), FMM-101(A), FZM-1(A) & FDM-1(A)

Monitor Modules with FlashScan®



Intelligent/Addressable Devices

General

Four different monitor modules are available for Notifier's intelligent control panels for a variety of applications. Monitor modules supervise a circuit of dry-contact input devices, such as conventional heat detectors and pull stations, or monitor and power a circuit of two-wire smoke detectors (FZM-1(A)).

FMM-1(A) is a standard-sized module (typically mounts to a 4" [10.16 cm] square box) that supervises either a Style D (Class A) or Style B (Class B) circuit of dry-contact input devices.

FMM-101(A) is a miniature monitor module a mere 1.3" (3.302 cm) H x 2.75" (6.985 cm) W x 0.5" (1.270 cm) D that supervises a Style B (Class B) circuit of dry-contact input devices. Its compact design allows the FMM-101(A) to be mounted in a single-gang box behind the device it monitors.

FZM-1(A) is a standard-sized module that monitors and supervises compatible two-wire, 24 volt, smoke detectors on a Style D (Class A) or Style B (Class B) circuit.

FDM-1(A) is a standard-sized dual monitor module that monitors and supervises two independent two-wire Style B (Class B) dry-contact initiating device circuits (IDCs) at two separate, consecutive addresses in intelligent, two-wire systems.

FlashScan® (U.S. Patent 5,539,389) is a communication protocol developed by NOTIFIER that greatly increases the speed of communication between analog intelligent devices. Intelligent devices communicate in a grouped fashion. If one of the devices within the group has new information, the panel CPU stops the group poll and concentrates on single points. The net effect is response speed greater than five times that of other designs.

FMM-1(A) Monitor Module

- Built-in type identification automatically identifies this device as a monitor module to the control panel.
- Powered directly by two-wire SLC loop. No additional power required.
- High noise (EMF/RFI) immunity.
- SEMS screws with clamping plates for ease of wiring.
- Direct-dial entry of address: 01 – 159 on FlashScan loops; 01 – 99 on CLIP loops.
- LED flashes green during normal operation (this is a programmable option) and latches on steady red to indicate alarm.

The FMM-1(A) Monitor Module is intended for use in intelligent, two-wire systems, where the individual address of each module is selected using the built-in rotary switches. It provides either a two-wire or four-wire fault-tolerant Initiating Device Circuit (IDC) for normally-open-contact fire alarm and supervisory devices. The module has a panel-controlled LED indicator. The FMM-1(A) can be used to replace MMX-1(A) modules in existing systems.

FMM-1(A) APPLICATIONS

Use to monitor a zone of four-wire smoke detectors, manual fire alarm pull stations, waterflow devices, or other normally-open dry-contact alarm activation devices. May also be used to monitor normally-open supervisory devices with special supervisory indication at the control panel. Monitored circuit may be wired as an NFPA Style B (Class B) or Style D (Class

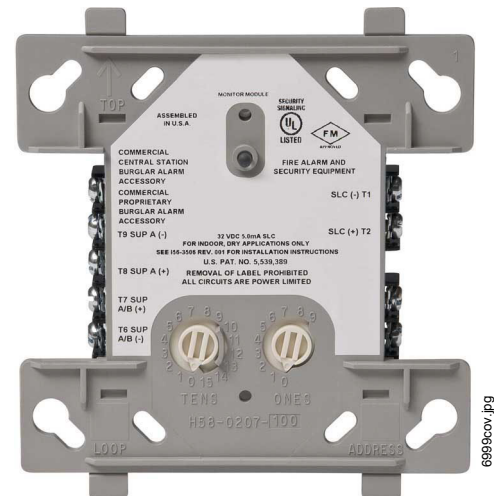

FMM-1(A) (Type H)

A) Initiating Device Circuit. A 47K ohm End-of-Line Resistor (provided) terminates the Style B circuit. No resistor is required for supervision of the Style D circuit.

FMM-1(A) OPERATION

Each FMM-1(A) uses one of the available module addresses on an SLC loop. It responds to regular polls from the control panel and reports its type and the status (open/normal/short) of its Initiating Device Circuit (IDC). A flashing LED indicates that the module is in communication with the control panel. The LED latches steady on alarm (subject to current limitations on the loop).

FMM-1(A) SPECIFICATIONS

Nominal operating voltage: 15 to 32 VDC.

Maximum current draw: 5.0 mA (LED on).

Average operating current: 350 μ A (LED flashing), 1 communication every 5 seconds, 47k EOL.

Maximum IDC wiring resistance: 40 ohms.

EOL resistance: 47K ohms.

Temperature range: 32°F to 120°F (0°C to 49°C).

Humidity range: 10% to 93% noncondensing.

Dimensions: 4.5" (11.43 cm) high x 4" (10.16 cm) wide x 1.25" (3.175 cm) deep. Mounts to a 4" (10.16 cm) square x 2.125" (5.398 cm) deep box.

FMM-101(A) Mini Monitor Module

- Built-in type identification automatically identifies this device as a monitor module to the panel.
- Powered directly by two-wire SLC loop. No additional power required.
- High noise (EMF/RFI) immunity.
- Tinned, stripped leads for ease of wiring.
- Direct-dial entry of address: 01 – 159 on FlashScan loops; 01 – 99 on CLIP loops.

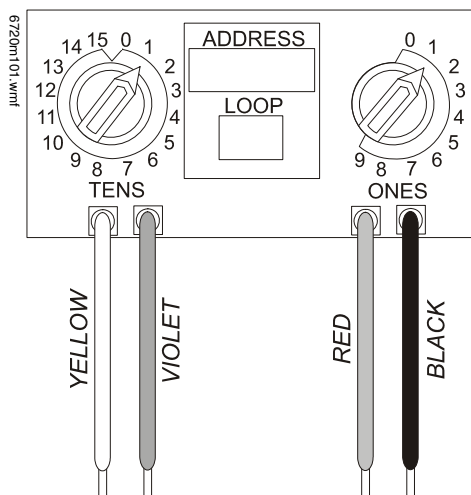

The FMM-101(A) Mini Monitor Module can be installed in a single-gang junction directly behind the monitored unit. Its small size and light weight allow it to be installed without rigid mounting. The FMM-101(A) is intended for use in intelligent, two-wire systems where the individual address of each module is selected using rotary switches. It provides a two-wire initiating device circuit for normally-open-contact fire alarm and security devices. The FMM-101(A) can be used to replace MMX-101(A) modules in existing systems.

FMM-101(A) APPLICATIONS

Use to monitor a single device or a zone of four-wire smoke detectors, manual fire alarm pull stations, waterflow devices, or other normally-open dry-contact devices. May also be used to monitor normally-open supervisory devices with special supervisory indication at the control panel. Monitored circuit/device is wired as an NFPA Style B (Class B) Initiating Device Circuit. A 47K ohm End-of-Line Resistor (provided) terminates the circuit.

FMM-101(A) OPERATION

Each FMM-101(A) uses one of the available module addresses on an SLC loop. It responds to regular polls from the control panel and reports its type and the status (open/normal/short) of its Initiating Device Circuit (IDC).

FMM-101(A) SPECIFICATIONS

Nominal operating voltage: 15 to 32 VDC.

Average operating current: 350 μ A, 1 communication every 5 seconds, 47k EOL; 600 μ A Max. (Communicating, IDC Shorted).

Maximum IDC wiring resistance: 40 ohms.

Maximum IDC Voltage: 11 Volts.

Maximum IDC Current: 400 μ A.

EOL resistance: 47K ohms.

Temperature range: 32°F to 120°F (0°C to 49°C).

Humidity range: 10% to 93% noncondensing.

Dimensions: 1.3" (3.302 cm) high x 2.75" (6.985 cm) wide x 0.65" (1.651 cm) deep.

Wire length: 6" (15.24 cm) minimum.

FZM-1(A) Interface Module

- Supports compatible two-wire smoke detectors.
- Supervises IDC wiring and connection of external power source.
- High noise (EMF/RFI) immunity.
- SEMS screws with clamping plates for ease of wiring.
- Direct-dial entry of address: 01 – 159 on FlashScan loops, 01 – 99 on CLIP loops.
- LED flashes during normal operation; this is a programmable option.
- LED latches steady to indicate alarm on command from control panel.

The FZM-1(A) Interface Module is intended for use in intelligent, addressable systems, where the individual address of each module is selected using built-in rotary switches. This module allows intelligent panels to interface and monitor two-wire conventional smoke detectors. It transmits the status (normal, open, or alarm) of one full zone of conventional detectors back to the control panel. All two-wire detectors being monitored must be UL compatible with the module. The FZM-1(A) can be used to replace MMX-2(A) modules in existing systems.

FZM-1(A) APPLICATIONS

Use the FZM-1(A) to monitor a zone of two-wire smoke detectors. The monitored circuit may be wired as an NFPA Style B (Class B) or Style D (Class A) Initiating Device Circuit. A 3.9 K ohm End-of-Line Resistor (provided) terminates the end of the Style B or D (class B or A) circuit (maximum IDC loop resistance is 25 ohms). Install ELR across terminals 8 and 9 for Style D application.

FZM-1(A) OPERATION

Each FZM-1(A) uses one of the available module addresses on an SLC loop. It responds to regular polls from the control panel and reports its type and the status (open/normal/short) of its Initiating Device Circuit (IDC). A flashing LED indicates that the module is in communication with the control panel. The LED latches steady on alarm (subject to current limitations on the loop).

FZM-1(A) SPECIFICATIONS

Nominal operating voltage: 15 to 32 VDC.

Maximum current draw: 5.1 mA (LED on).

Maximum IDC wiring resistance: 25 ohms.

Average operating current: 300 μ A, 1 communication and 1 LED flash every 5 seconds, 3.9k eol.

EOL resistance: 3.9K ohms.

External supply voltage (between Terminals T3 and T4): DC voltage: 24 volts power limited. Ripple voltage: 0.1 Vrms maximum. Current: 90 mA per module maximum.

Temperature range: 32°F to 120°F (0°C to 49°C).

Humidity range: 10% to 93% noncondensing.

Dimensions: 4.5" (11.43 cm) high x 4" (10.16 cm) wide x 1.25" (3.175 cm) deep. Mounts to a 4" (10.16 cm) square x 2.125" (5.398 cm) deep box.

FDM1(A) Dual Monitor Module

The FDM-1(A) Dual Monitor Module is intended for use in intelligent, two-wire systems. It provides two independent two-wire initiating device circuits (IDCs) at two separate, consecutive addresses. It is capable of monitoring normally open contact fire alarm and supervisory devices; or either normally open or normally closed security devices. The module has a single panel-controlled LED.

NOTE: The FDM-1(A) provides two Style B (Class B) IDC circuits ONLY. Style D (Class A) IDC circuits are NOT supported in any application.

FDM-1(A) SPECIFICATIONS

Normal operating voltage range: 15 to 32 VDC.

Maximum current draw: 6.4 mA (LED on).

Average operating current: 750 μ A (LED flashing).

Maximum IDC wiring resistance: 1,500 ohms.

Maximum IDC Voltage: 11 Volts.

Maximum IDC Current: 240 μ A

EOL resistance: 47K ohms.

Maximum SLC Wiring resistance: 40 Ohms.

Temperature range: 32° to 120°F (0° to 49°C).

Humidity range: 10% to 93% (non-condensing).

Dimensions: 4.5" (11.43 cm) high x 4" (10.16 cm) wide x 2.125" (5.398 cm) deep.

FDM-1(A) AUTOMATIC ADDRESSING

The FDM-1(A) automatically assigns itself to two addressable points, starting with the original address. For example, if the FDM-1(A) is set to address "26", then it will automatically assign itself to addresses "26" and "27".

NOTE: "Ones" addresses on the FDM-1(A) are 0, 2, 4, 6, or 8 only. Terminals 6 and 7 use the first address, and terminals 8 and 9 use the second address.



CAUTION:

Avoid duplicating addresses on the system.

Installation

FMM-1(A), FZM-1(A), and FDM-1(A) modules mount directly to a standard 4" (10.16 cm) square, 2.125" (5.398 cm) deep, electrical box. They may also be mounted to the SMB500 surface-mount box. Mounting hardware and installation instructions are provided with each module. All wiring must conform to applicable local codes, ordinances, and regulations. These modules are intended for power-limited wiring only.

The FMM-101(A) module is intended to be wired and mounted without rigid connections inside a standard electrical box. All wiring must conform to applicable local codes, ordinances, and regulations.

Agency Listings and Approvals

In some cases, certain modules may not be listed by certain approval agencies, or listing may be in process. Consult factory for latest listing status.

- **UL:** S635
- **ULC:** S635
- **FM Approved**
- **CSFM:** 7300-0028:0219
- **MEA:** 457-99-E
- **U.S. Coast Guard:**

– 161.002/23/3 (AFP-200: FMM-1/-101, FZM-1)

– 161.002/42/1 (NFS-640: FMM-1/-101)

- **Lloyd's Register:**

– 03/60011/E1 (FMM-1/-101, FZM-1)

– 94/60004/E2 (AFP-200: *except* FDM-1)

– 02/60007 (NFS-640: FDM-1)

- **FDNY:** COA #6038 (NFS2-640, NFS-320), COA# 6058 (NFS2-3030)

Product Line Information

NOTE: "A" suffix indicates ULC-listed model.

FMM-1(A): Monitor module.

FMM-101(A): Monitor module, miniature.

FZM-1(A): Monitor module, two-wire detectors.

FDM-1(A): Monitor module, dual, two independent Class B circuits.

SMB500: Optional surface-mount backbox.

NOTE: See installation instructions and refer to the SLC Wiring Manual, PN 51253.

FlashScan® and NOTIFIER® are registered trademarks and FireWatch™ is a trademark of Honeywell International Inc.
©2010 by Honeywell International Inc. All rights reserved. Unauthorized use of this document is strictly prohibited.



This document is not intended to be used for installation purposes.
We try to keep our product information up-to-date and accurate.
We cannot cover all specific applications or anticipate all requirements.
All specifications are subject to change without notice.

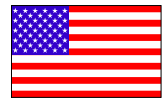

Made in the U.S. A.

For more information, contact Notifier. Phone: (203) 484-7161, FAX: (203) 484-7118.
www.notifier.com

SpectrAlert® Advance

Selectable Output Notification Appliances



Audio/Visual Devices

General

System Sensor® SpectrAlert® Advance selectable-output horns, strobes and horn/strobes are rich with features guaranteed to cut installation times and maximize profits. The SpectrAlert Advance series of notification appliances is designed to simplify your installations, with features such as: plug-in designs, instant feedback messages to ensure correct installation of individual devices, and eleven field-selectable candela settings for wall and ceiling strobes and horn/strobes.

More specifically, when installing Advance products, first attach a universal mounting plate to a four-inch square, four-inch octagon, or double-gang junction box. The two-wire mounting plate attaches to a single-gang junction box.

Then, connect the notification appliance circuit wiring to the SEMS terminals on the mounting plate.

Finally, attach the horn, strobe, or horn/strobe to the mounting plate by inserting the product's tabs in the mounting plate's grooves. The device will rotate into position, locking the product's pins into the mounting plate's terminals. The device will temporarily hold in place with a catch until it is secured with a captured mounting screw.

SpectrAlert Advance products allow you to choose:

- 12 or 24 volts.
- 15, 15/75, 30, 75, 95, 110, 115, 135, 150, 177, or 185 candela by way of a rear-mounted slide switch and front viewing window.
- Horn tones and volume by way of a rotary switch.
- The SpectrAlert Advance series includes outdoor notification appliances. Outdoor strobes and horn/strobes (two-wire and four-wire) are available for wall or ceiling. Outdoor horns are available for wall only. All System Sensor outdoor products are rated between -40°F and 151°F (-40°C and 66°C) in wet or dry applications.

Models available:

- Indoor wall-mount: horn, strobe, 2-wire horn/strobe, 4-wire horn/strobe.
- Indoor ceiling-mount: strobe, 2-wire horn/strobe, 4-wire horn/strobe.
- Outdoor wall-mount: horn, strobe, 2-wire horn/strobe, 4-wire horn/strobe.
- Outdoor ceiling-mount: strobe, 2-wire horn/strobe, 4-wire horn/strobe.

Features

- Plug-in design.
- Same mounting plate for wall- and ceiling-mount units.
- Shorting spring on mounting plate for continuity check before installation.
- Captive mounting screw.
- Tamper-resistance capability.
- Field-selectable candela settings on wall and ceiling units: 15, 15/75, 30, 75, 95, 110, 115, 135, 150, 177, 185.
- Automatic selection of 12 or 24 volt operation at 15 and 15/75 candela.
- Outdoor wall and ceiling products.



Indoor Ceiling
Horn/Strobe



Outdoor Ceiling
Strobe



Indoor Wall
Horn/Strobe



Indoor Ceiling
Strobe



Indoor Wall
Horn



Outdoor Wall
Strobe

- Outdoor products rated from -40°F and 151°F (-40°C and 66°C).
- Outdoor products rainproof per UL50 (NEMA 3R) and weatherproof per NEMA 4X, IP56
- Minimal intrusion into the backbox.
- Horn rated at 88+ dbA at 16 volts.
- Rotary switch for tone selection.
- Three horn volume settings.
- Electrically compatible with existing SpectrAlert products.

Engineering Specifications

SpectrAlert Advance horns, strobes, and horn/strobes shall mount to a standard 4.0" x 4.0" x 1.5" (10.16 x 10.16 x 3.81 cm) backbox, 4.0" (10.16 cm) octagonal backbox, or a double-gang backbox. Two-wire products shall also mount to a single-gang 2.0" x 4.0" x 1.875" (5.08 x 10.16 x 4.763 cm) backbox. A universal mounting plate shall be used for mounting ceiling and wall products. The notification appliance circuit wiring shall terminate at the universal mounting plate. Also, SpectrAlert Advance products, when used with the Sync•Circuit™ Module accessory, shall be powered from a non-coded notification appliance circuit output and shall operate on a nominal 12 or 24 volts. When used with the Sync•Circuit Module, 12-volt rated notification appliance circuit outputs shall operate between 9 and 17.5 volts; 24-volt rated notification appliance circuit outputs shall operate between 17 and 33 volts. Indoor SpectrAlert Advance products shall operate between 32°F and 120°F (0°C and 49°C) from a regulated DC, or full-wave-rectified, unfiltered power supply. Strobes and horn/strobes shall have field-selectable candela settings including 15, 15/75, 30, 75, 95, 110, 115, 135, 150, 177, 185.

STROBE

The strobe shall be a System Sensor SpectrAlert Advance Model _____ listed to UL 1971 and shall be approved for fire protective service. The strobe shall be wired as a primary-signaling notification appliance and comply with the Americans with Disabilities Act requirements for visible signaling appliances, flashing at 1 Hz over the strobe's entire operating voltage range. The strobe light shall consist of a xenon flash tube and associated lens/reflector system.

HORN/STROBE COMBINATION

The horn/strobe shall be a System Sensor SpectrAlert Advance Model _____ listed to UL 1971 and UL 464 and shall be approved for fire protective service. The horn/strobe shall be wired as a primary-signaling notification appliance and comply with the Americans with Disabilities Act requirements for visible signaling appliances, flashing at 1 Hz over the strobe's entire operating voltage range. The strobe light shall consist of a xenon flash tube and associated lens/reflector system. The horn shall have three audibility options and an option to switch between a Temporal 3 pattern and a Non-Temporal (continuous) pattern. These options are set by a multiple position switch. On four-wire products, the strobe shall be powered independently of the sounder. The horn on horn/strobe models shall operate on a coded or non-coded power supply.

OUTDOOR PRODUCTS

SpectrAlert Advance outdoor horns, strobes and horn/strobes shall be listed for outdoor use by UL and shall operate between -40°F and 151°F (-40°C and 66°C). The products shall be listed for use with a System Sensor outdoor/weather-proof backbox with half-inch and three-fourths-inch conduit entries.

SYNCHRONIZATION MODULE

The module shall be a System Sensor Sync•Circuit MDL3R or MDL3W listed to UL 464 and shall be approved for fire protective service. The module shall synchronize SpectrAlert strobes at 1 Hz and horns at Temporal 3. Also, while operating the strobes, the module shall silence the horns on horn/strobe models over a single pair of wires. The module shall mount to a 4.688" x 4.688" x 2.125" (11.906 x 11.906 x 5.398 cm) backbox. The module shall also control two Style Y (class B) circuits or one Style Z (Class A) circuit. The module shall synchronize multiple zones. Daisy-chaining two or more synchronization modules together will synchronize all the zones they control. The module shall not operate on a coded power supply.

Strobe Current Draw, UL Maximum (mA RMS)

Candela	8 – 17.5 V		16 – 33 V		
	DC	FWR	DC	FWR	
Standard Candela Range	15	123	128	66	71
	15/75	142	148	77	81
	30	NA	N/A	94	96
	75	NA	NA	158	153
	95	NA	NA	181	176
	110	NA	NA	202	195
	115	NA	NA	210	205
High Candela Range	135	NA	NA	228	207
	150	NA	NA	246	220
	177	NA	NA	281	251
	185	NA	NA	286	258

Operating Specifications

- **Standard operating temperature:** 32°F to 120°F (0°C to 49°C).
- **K Series operating temperature:** -40°F to 151°F (-40°C to 66°C).
- **Humidity range:** 10% to 93% non-condensing (indoor products).
- **Strobe flash rate:** 1 flash per second.
- **Nominal voltage:** regulated 12 VDC/FWR or regulated 24 VDC/FWR. **NOTE:** Full Wave Rectified (FWR) voltage is a non-regulated, time-varying power source that is used on some power supply and panel outputs.
- **Operating voltage range:** 8 V to 17.5 V (12 V nominal); or 16 V to 33 V (24 V nominal). **NOTE:** P, S, PC, and SC products will operate at 12 V nominal only for 15 cd and 15/75 cd.
- **Input terminal wire gauge:** 12 to 18 AWG (3.31 to 0.821 mm²).
- **Ceiling-mount dimensions (including lens):** 6.8" diameter x 2.5" deep (17.3 cm diameter x 6.4 cm deep).
- **Wall-mount dimensions (including lens):** 5.6" H x 4.7" W x 2.5" D (14.2 cm H x 11.9 cm W x 6.4 cm D).
- **Horn dimensions:** 5.6" H x 4.7" W x 1.3" D (14.2 cm H x 11.9 cm W x 3.3 cm D).

Agency Listings and Approvals

The listings and approvals below apply to SpectrAlert Advance Selectable Output Notification Devices. In some cases, certain modules may not be listed by certain approval agencies, or listing may be in process. Consult factory for latest listing status.

- **UL Listed:** S4011 (HR__, HW__, P2__, P4__, PC2__, PC4__ models); S5512 (models SCR, SCRH, SCW, SCWH, SR, SRH, SW, SWH); S3593 (SCRHK, SCRK, SRHK, SRK).
- **ULC Listed:** S4011 (HRA, HRKA); S5512 (typically "A" models, with exception of outdoor strobes). See Canadian data sheet for listings and specifications.
- **FM approved**
- **MEA: 452-05-E**
- **CSFM: 7125-1653:0186** (SCR, SCRH, SCW, SCWH, SR, SRH, SW, SWH); **7300-1653:0188** (P2_, P4_, PC2_, PC4_ modules); **7135-1653:0189** (HR, HRK, HW); **7300-1653:0187** (SCRHK, SCRK, SRHK, SRK).

Horn Current Draw, UL Maximum (mA RMS)

Sound Pattern	dB	8 – 17.5 V		16 – 33 V	
		DC	FWR	DC	FWR
Temporal	High	57	55	69	75
Temporal	Medium	44	49	58	69
Temporal	Low	38	44	44	48
Non-temporal	High	57	56	69	75
Non-temporal	Medium	42	50	60	69
Non-temporal	Low	41	44	50	50
Coded	High	57	55	69	75
Coded	Medium	44	51	56	69
Coded	Low	40	46	52	50

Horn and Horn/Strobe Rotary Switch Setting

Setting	Repetition Rate	dB Level
1	Temporal horn	High
2	Temporal horn	Medium
3	Temporal horn	Low
4	Normal horn	High
5	Normal horn	Medium
6	Normal horn	Low
7*	Externally coded	High
8*	Externally coded	Medium
9*	Externally coded	Low

***NOTE:** Settings 7, 8, and 9 are not available on 2-wire horn/strobe.

Horn and Horn/Strobe Output (dBA)

Switch Position	Sound Pattern	dB	8 – 17.5 V		16 – 33 V	
			DC	FW R	DC	FW R
1	Temporal	High	78	78	84	84
2	Temporal	Medium	74	74	80	80
3	Temporal	Low	71	73	76	76
4	Non-temporal	High	82	82	88	88
5	Non-temporal	Medium	78	78	85	85
6	Non-temporal	Low	75	75	81	81
7*	Coded	High	82	82	88	88
8*	Coded	Medium	78	78	85	85
9*	Coded	Low	75	75	81	81

***NOTE:** Settings 7, 8, and 9 are not available on 2-wire horn/strobe.

Two-Wire Horn/Strobe, **STANDARD** Candela Range (15 – 115 cd), UL Maximum Current Draw (mA RMS)

Input, Sound Pattern, dB Level	8 – 17.5 V		16 – 33 V						
	15	15/75	15	15/75	30	75	95	110	115
DC Input, Temporal, High	137	147	79	90	107	176	194	212	218
DC Input, Temporal, Medium	132	144	69	80	97	157	182	201	210
DC Input, Temporal, Low	132	143	66	77	93	154	179	198	207
DC Input, Non-temporal, High	141	152	91	100	116	176	201	221	229
DC Input, Non-temporal, Medium	133	145	75	85	102	163	187	207	216
DC Input, Non-temporal, Low	131	144	68	79	96	156	182	201	210
FWR Input, Temporal, High	136	155	88	97	112	168	190	210	218
FWR Input, Temporal, Medium	129	152	78	88	103	160	184	202	206
FWR Input, Temporal, Low	129	151	76	86	101	160	184	194	201
FWR Input, Non-temporal, High	142	161	103	112	126	181	203	221	229
FWR Input, Non-temporal, Medium	134	155	85	95	110	166	189	208	216
FWR Input, Non-temporal, Low	132	154	80	90	105	161	184	202	211

Two-Wire Horn/Strobe, **HIGH** Candela Range (135 – 185 cd), UL Maximum Current Draw (mA RMS)

DC Input	16 – 33 V				FWR Input	16 – 33 V			
	135	150	177	185		135	150	177	185
DC, Temporal, High	245	259	290	297	FWR, Temporal, High	215	231	258	265
DC, Temporal, Medium	235	253	288	297	FWR, Temporal, Medium	209	224	250	258
DC, Temporal, Low	232	251	282	292	FWR, Temporal, Low	207	221	248	256
DC, Non-temporal, High	255	270	303	309	FWR, Non-temporal, High	233	248	275	281
DC, Non-temporal, Medium	242	259	293	299	FWR, Non-temporal, Medium	219	232	262	267
DC, Non-temporal, Low	238	254	291	295	FWR, Non-temporal, Low	214	229	256	262

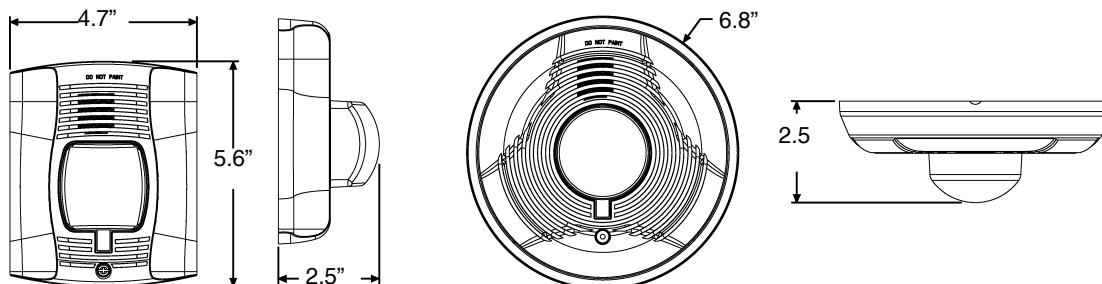

Ordering Information

Model	Description	Model	Description
WALL HORN/STROBES		CEILING HORN/STROBES	
P2R	2-wire horn/strobe, standard cd, red.	PC2R	2-wire horn/strobe, standard cd, red.
P2RH	2-wire horn/strobe, high cd, red.	PC2RH	2-wire horn/strobe, high cd, red.
P2RK	2-wire horn/strobe, standard cd, red, outdoor.	PC2RK	2-wire horn/strobe, standard cd, red, outdoor.
P2RHK	2-wire horn/strobe, high cd, red, outdoor.	PC2RHK	2-wire horn/strobe, high cd, red, outdoor.
P2W	2-wire horn/strobe, standard cd, white.	PC2W	2-wire horn/strobe, standard cd, white.
P2WH	2-wire horn/strobe, high cd, white.	PC2WH	2-wire horn/strobe, high cd, white.
P4R	4-wire horn/strobe, standard cd, red.	PC4R	4-wire horn/strobe, standard cd, red.
P4RH	4-wire horn/strobe, high cd, red.	PC4RH	4-wire horn/strobe, high cd, red.
P4RK	4-wire horn/strobe, standard cd, red, outdoor.	PC4RK	4-wire horn/strobe, standard cd, red, outdoor.
P4RHK	4-wire horn/strobe, high cd, red, outdoor.	PC4RHK	4-wire horn/strobe, high cd, red, outdoor.
P4W	4-wire horn/strobe, standard cd, white.	PC4W	4-wire horn/strobe, standard cd, white.
P4WH	4-wire horn/strobe, high cd, white.	PC4WH	4-wire horn/strobe, high cd, white.
WALL STROBES		CEILING STROBES	
SR	Strobe, standard cd, red.	SCR	Strobe, standard cd, red.
SRH	Strobe, high cd, red.	SCRH	Strobe, high cd, red.
SRK	Strobe, standard cd, red, outdoor.	SCRK	Strobe, standard cd, red, outdoor.
SRHK	Strobe, high cd, red, outdoor.	SCRHK	Strobe, high cd, red, outdoor.
SW	Strobe, standard cd, white.	SCW	Strobe, standard cd, white.
SWH	Strobe, high cd, white.	SCWH	Strobe, high cd, white.
ACCESSORIES		HORNS	
BBS-2A	Backbox skirt, wall, red.	HR	Horn, red.
BBSW-2A	Backbox skirt, wall, white.	HRK	Horn, red, outdoor.
BBSC-2A	Backbox skirt, ceiling, red.	HW	Horn, white.
BBSCW-2A	Backbox skirt, ceiling, white.	ACCESSORIES, continued	
SA-WBB	Weatherproof backbox, wall.	TR-HS	Trim Ring, wall, red, package of 5
SA-WBBC	Weatherproof backbox, ceiling.	TRW-HS	Trim Ring, wall, white, package of 5
WTP	Weatherproof, flush mount plate, red	TRC-HS	Trim Ring, ceiling, red, package of 5
WTPW	Weatherproof, flush mount plate, white	TRCW-HS	Trim Ring, ceiling, white, package of 5
<p>NOTE: "High cd" refers to strobes that include 135, 150, 177, and 185 candela settings. "Standard cd" refers to strobes that include 15, 15/75, 30, 75, 95, 110, and 115 candela settings.</p> <p>NOTE: For strobes and horn/strobes, add suffix "F" for French or "B" for Bilingual.</p> <p>NOTE: All outdoor models ("K(A)" suffix) include a plastic weatherproof backbox.</p> <p>NOTE: Add "-R" to models for weatherproof replacement device (no back box included). Only for use with weatherproof outdoor flush mounting plate, WTP and WTPW.</p> <p>NOTE: Add "P" to model for plain housing. (No "FIRE" marking on cover.)</p>			

SyncCircuit™ is a trademark and NOTIFIER® and SpectraAlert® are registered trademarks of Honeywell International Inc.
 ©2011 by Honeywell International Inc. All rights reserved. Unauthorized use of this document is strictly prohibited.



This document is not intended to be used for installation purposes.
 We try to keep our product information up-to-date and accurate.
 We cannot cover all specific applications or anticipate all requirements.
 All specifications are subject to change without notice.

For more information, contact Notifier. Phone: (203) 484-7161, FAX: (203) 484-7118.
www.notifier.com

SpectrAlert® Advance

Indoor Selectable Output Speaker Strobes and Dual Voltage Evacuation Speakers



Audio/Visual Devices

General

The SpectrAlert Advance Series of speakers and speaker strobes is designed to reduce ground faults. The plug-in design allows the installer to pre-wire mounting plates and dress the wires before plugging in the speakers. The plastic cover prevents nicked wires by covering exposed speaker components.

This design also allows faster installations with instant feedback to ensure that wiring is properly connected; rotary switches to select voltage and power settings; and 11 field selectable candela settings for wall and ceiling speaker strobes.

The low total harmonic distortion of the SP speaker offers high fidelity sound output while the SPV speaker offers high volume sound output for use in high ambient noise applications.

SpectrAlert Advance makes installation easy

- Attach a universal mounting plate to a 4" x 4" x 2-1/8" back box. Flush mount applications are achievable without the need for an extension ring.
- Connect the notification appliance circuit or speaker wiring to the PEMS terminals on the mounting plate.
- Attach the speaker or speaker strobe to the mounting plate by inserting the product tabs into the mounting plate grooves. Rotate the device into position to lock the product pins into the mounting plate terminals. The device will temporarily hold in place with a catch until it is secured with a captured mounting screw.

Features

- Plug-in design
- Protective cover isolates speaker components, reduces ground faults
- Electrical compatibility with existing SpectrAlert products
- Field selectable candela settings on wall and ceiling units:
 - Standard: 15, 15/75, 30, 75, 95, 110, 115
 - High: 135, 150, 177, 185
- Shorting spring on mounting plate tests continuity before installation
- Rotary switch simplifies field selection of speaker voltage and power settings
- Universal mounting plate for wall- and ceiling-mount units
- Compatible with System Sensor synchronization protocol
- SP speakers offer high fidelity sound output
- SPV speakers offer high volume sound output
- Automatic selection of 12 or 24 volt operation at 15 and 15/75 candela
- No extension ring required
- Ceiling and wall mount application
- Optional tamper resistant Torx head screw included

Specifications

PHYSICAL SPECIFICATIONS

Operating Temperature: 32°F to 120°F (0°C to 49°C)

Humidity Range: 10 to 93% non-condensing

Dimensions, Wall-Mount: –

- SPS Speaker Strobe: 6.0"L x 5.0"W x 4.7"D (includes lens and speaker)



- SPSV Speaker Strobe: 6.0"L x 5.0"W x 4.9"D (includes lens and speaker)
- SP Speaker: 6.0"L x 5.0"W x 2.8"D
- SPSV Speaker: 6.0"L x 5.0"W x 2.9"D

Dimensions, Ceiling-Mount:

- SPS Speaker Strobe: 6.8"Dia x 4.7"D (includes lens and speaker)
- SPSV Speaker Strobe: 6.8"Dia x 4.8"D (includes lens and speaker)
- SP Speaker: 6.8"Dia x 2.8"D
- SPSV Speaker: 6.8"Dia x 2.9"D

ELECTRICAL/OPERATING SPECIFICATIONS

Nominal Voltage (speakers): 25 Volts or 70.7 Volts (nominal)

Maximum Supervisory Voltage (speakers): 50VDC

Strobe Flash Rate: 1 flash per second

Nominal Voltage (strobes): Regulated 12VDC/FWR or regulated 24DC/FWR

Operating Voltage Range (includes fire alarm panels with built-in sync): 8 to 17.5V (12V nominal) or 16 to 33V (24V nominal)

Operating Voltage with MDL Sync Module: 9 to 17.5V (12V nominal) or 17 to 33V (24V nominal)

Frequency Range: 400 to 4000 Hz

Power: ¼, ½, 1, 2 watts

Agency Listings and Approvals

In some cases, certain modules may not be listed by certain approval agencies, or listing may be in progress. *Consult factory for latest listing status.*

- **UL/ULC Listed:** S4048
- **MEA:** 10-08-E
- **CSFM:** 7320-1653:201
- **FM Approved**

UL Maximum Strobe Current Draw (mA RMS)					
	Candela	8 to 17.5 Volts		16 to 33 Volts	
		DC	FWR	DC	FWR
Standard Candela Range	15	123	128	66	71
	15/75	142	148	77	81
	30	NA	NA	94	96
	75	NA	NA	158	153
	95	NA	NA	181	176
	110	NA	NA	202	195
	115	NA	NA	210	205
High Candela Range	135	NA	NA	228	207
	150	NA	NA	246	220
	177	NA	NA	281	251
	185	NA	NA	286	258

Sound Output					
UL Reverberant (dBA @ 10ft)	2W	1W	1/2W	1/4W	
Wall Mount SP Series	86	83	80	77	
Wall Mount SPV Series	90	87	84	81	
Ceiling Mount SPC Series	86	83	80	77	
Ceiling Mount SPCV Series	90	87	84	81	
Wall Mount SPS Series	85	82	79	76	
Wall Mount SPSV Series	89	86	83	80	
Ceiling Mount SPSC Series	85	82	79	76	
Ceiling Mount SPSCV Series	89	86	83	80	

Architectural/Engineering Specifications

GENERAL

SpectrAlert Advance speaker and speaker strobes shall mount to a 4" x 4" x 2-1/8" backbox. A universal mounting plate shall be used for mounting ceiling and wall products. The notification appliance circuit and amplifier wiring shall terminate at the universal mounting plate. Also, SpectrAlert Advance speaker strobes, when used with the Sync Circuit. Module accessory, shall be powered from a non-coded notification appliance circuit output and shall operate on a nominal 12 or 24volts. When used with the Sync.Circuit Module, 12 volt rated notification appliance circuit outputs shall operate between nine and 17.5 volts; 24 volt rated notification appliance circuit outputs shall operate between 17 and 33 volts. Indoor SpectrAlert Advance products shall operate between 32°F and 120°F from a regulated DC, or full-wave rectified, unfiltered power supply. Speaker strobes shall have field-selectable candela settings including 15, 15/75, 30, 75, 95, 110, 115, 135, 150, 177, 185.

SPEAKER

The speaker shall be a System Sensor SpectrAlert Advance model dual-voltage transformer speaker capable of operating at 25.0 or 70.7 nominal Vrms. It should be listed to UL/ULC 1480 and shall be approved for fire protective service. The speaker shall have a frequency range of 400 to 4000Hz and shall have an operating temperature between 32°F and 120°F. Speaker shall have power taps and voltage that are selected by rotary switches.

SPEAKER STROBE COMBINATION

The speaker strobe shall be a System Sensor SpectrAlert Advance model listed to UL1480 and UL/ULC 1971 and be approved for fire protective signaling systems. Speaker shall be capable of operating at 25.0 or 70.7 nominal Vrms selected via rotary switch, and shall have a frequency range of 400 to 4000Hz. Speaker shall have power taps which are selected by rotary switch. The strobe shall comply with the NFPA 72 requirements for visible signaling appliances, flashing at 1Hz over the strobe's entire operating voltage range. The strobe light shall consist of a xenon flash tube and associated lens/reflector system.

SYNCHRONIZATION MODULE

The module shall be a System Sensor Sync Circuit model MDL listed to UL/ULC 464 and shall be approved for fire protective service. The module shall synchronize SpectrAlert strobes at 1Hz. The module shall mount to a 4-11/16" x 4-11/16" x 2-1/8" backbox. The module shall also control two Style Y (class B) circuits or one Style Z (class A) circuit. The module shall synchronize multiple zones. Daisy chaining two or more synchronization modules together will synchronize all the zones they control. The module shall not operate on a coded power supply.

Ordering Information

NOTE: (W) indicates white coloring; (R), red.

NOTE: "A" suffix indicates ULC-Listed model.

WALL MOUNT

SP(W)(R)(A): Speaker only.

SP(W)(R)V(A): Speaker only, high dB; white.

SPS(W)(R)(A)*: Speaker strobe, selectable candela (15, 15/75, 30, 75, 95, 110, 115).

SPS(W)(R)H(A)*: Speaker strobe, selectable candela, high cd (135, 150, 177, 185).

SPS(W)(R)V(A)*: Speaker strobe, selectable candela, high dB.

CEILING MOUNT

SPC(W)(R)(A): Speaker only.

SPC(W)(R)V(A): Speaker only, high dB.

SPSC(W*)(R)(A): Speaker strobe, selectable candela (15, 15/75, 30, 50, 75, 95, 110, 115)

SPSC(W*)(R)H(A): Speaker strobe, selectable candela, high cd (135, 150, 177, 185)

SPSC(W*)(R)V(A): Speaker strobe, selectable candela, high dB (15, 15/75, 30, 50, 75, 95, 110, 115).

SPSC(W*)(R)VH(A): Speaker strobe, selectable candela, high dB, high cd (135, 150, 177, 185).

ACCESSORIES

RFP(A): Retrofit plate (5 pack), red.

RFPW(A): Retrofit plate (5 pack), white.

SPBBSC(A): Ceiling mount backbox skirt, red.

SPBBSCW(A): Ceiling mount backbox skirt, white.

SPBBS(A): Wall mount backbox skirt, red.

SPBBSW(A): Wall mount backbox skirt, white.

TR(A): Wall mount trim ring, red, package of 5.

TRW(A): Wall mount trim ring, white, package of 5.

TRC(A): Ceiling mount trim ring, red, package of 5.

TRCW(A): Ceiling mount trim ring, white, package of 5.

MWBB(A): Wall mount, metal weatherproof backbox

MWBBW(A): Wall mount, metal weatherproof backbox, white

MWBBC(A): Ceiling mount, metal weatherproof backbox

MWBBCW(A): Ceiling mount, metal weatherproof backbox, white

***NOTE:** Add -P to model number for plain housing (no 'FIRE' marking on the cover), e.g. SPSW-P

SpectrAlert® is a registered trademark of Honeywell International Inc.
©2011 by Honeywell International Inc. All rights reserved. Unauthorized use of this document is strictly prohibited.



This document is not intended to be used for installation purposes.
We try to keep our product information up-to-date and accurate.
We cannot cover all specific applications or anticipate all requirements.
All specifications are subject to change without notice.



Made in the U.S.A.

For more information, contact Notifier. Phone: (203) 484-7161, FAX: (203) 484-7118.
www.notifier.com

Multi-Voltage Conventional Relays



Miscellaneous

General

Notifier's multi-voltage conventional relays are used for high-current switching applications such as fan and damper assembly control, door control, air handling unit controls, and other types of system interfacing.

The R-10T(A)/20T(A) and R-14T(A)/R-24T(A) models are multi-voltage relays with terminal strip field wiring connections, mounting track and hardware. The R-10T(A) is a single FORM-C (SPDT) relay with a red activation LED, and the R-14T(A) is a 4-gang 1 FORM-C (SPDT) relay with 4 red activation LEDs. The R-20T(A) is a single 2 FORM-C (DPDT) relay with red activation LED, and the R-24T(A) is a 4-gang 2 FORM-C (DPDT) relay with 4 red activation LEDs.

The R-10E(A)/R-20E(A) and R-14E(A)/R-24E(A) are similar to the T series track mount relays, but they are mounted into a steel enclosure. The enclosure has a removable front cover that provides easy access and a LED viewing hole on the top of the cover.

PR-1(A)/PR-2(A)/PR-3(A) are epoxy encapsulated multi-voltage relays. They are single pole double throw relays that use a red LED as a visible indication of relay coil energization. PR-3 is identical to PR-2 except it has an extra pair of wires for redundant power input.

Model EOLR-1(A) is an epoxy encapsulated single pole single throw, normally open relay that can be used as an end of line device in fire alarm systems, e.g. to supervise power supplies.

Specifications

R-10T(A)/R-14T(A)/R-20T(A)/ R-24(A)T

Operating Voltage Range: 18-35 VDC, 18-35 VAC, 115 VAC, 230 VAC.

Operating Current: 23 mA @ 24 VDC, 59 mA @ 24 VAC, 150 mA @ 120 VAC, 180 mA @ 240 VAC [R-10T(A)/R-14T(A)].

40 mA DC max. @ 24 VDC, 24 VAC, 92 mA @ 24 VAC, 220 mA @ 120 VAC, 260 mA @ 240 VAC [R-20T(A)/R-24T(A)]

Humidity Range: 10% to 93% (non-condensing).

Dimensions: R-10T(A)/ R-20T(A): 2.5"L x 3.35"W x 1.2"H.

R-14T(A)/R-24T(A): 10"L x 3.35"W x 1.2"H.

Operating Temperature: -40° F to 158° F (-40°C to 70°C)

Contact Ratings: 24 VDC: 7A with L/R = 5 mS.
120 VAC: 10 A.
120 VAC: 1/6 HP.
230 VAC: 7 A.

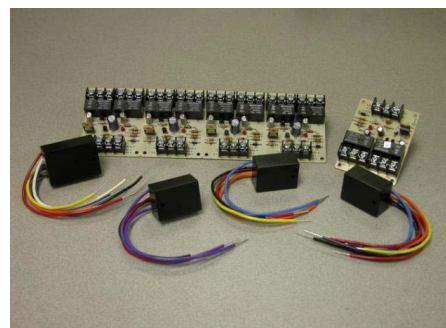

Multi-Voltage Conventional Relays

7015dn015g101

R-10E(A)/ R-14E(A)/R-20E(A)/ R-24E(A)

Operating Voltage Range: 18-35 VDC, 18-35 VAC, 115 VAC, 230 VAC.

Operating Current: 23 mA DC max. @ 24 V, 59 mA @ 24 VAC, 150 mA @ 120 VAC, 180 mA @ 240 VAC [R-10E(A)/R-14E(A)].

-40 mA DC max. @ 24 VDC, 24 VAC, 115 VAC, 230 VAC (R-20E/R-24E).

Humidity Range: 10% to 93% (non-condensing).

Dimensions: R-10E(A)/R-20E(A): 5.1"L x 3.75"W x 2.5"H.

R-14E(A)/R-24E(A): 11"L x 5.3"W x 2.5"H.

Operating Temperature: -40° F to 158° F (-40° C to 70° C).

Contact Ratings: 24 VDC: 7 A with L/R = 5mS.
120 VAC: 10 A.
120 VAC: 1/6 HP.
230 VAC: 7 A.

PR-1(A)

Operating Voltage Range: 18-35 VDC, 18-35 VAC, 120 VAC.

Operating Current: 15 mA DC max. @ 24 VDC, 24 VAC, 120VAC.

Humidity Range: 10% to 93% RH.

Dimensions: 0.87" H x 2.01" W x 1.42" D.

Operating Temperature: -40° F to 158° F (-40° C to 70° C).

Contact Ratings: 24 VDC: 7 A with LR = 5 mS.
120 VAC: 7 A max. (0.35 PF).
250 VAC: 10 A resistive.
30 VDC: 10 A resistive.

Wire Length: 8" minimum.

PR-2(A)/PR-3(A)

Operating Voltage Range:	10 to 40 VDC.
Operating Current:	30 mA DC max.
Humidity Range:	10% to 93% RH.
Dimensions:	0.91" H x 1.65" W x 1.22" D.
Operating Temperature:	-40° F to 158° F (-40° C to 70° C).
Contact Ratings:	120 VAC: 10 A (resistive load). 120 VAC: 7 A max. (0.35 PF). 250 VAC: 10 A max. (resistive load). 30 VDC: 10 A max. (resistive load).
Wire Length:	8" minimum.

EOLR-1(A)

Operating Voltage Range:	9 to 40 VDC.
Operating Current:	20 mA DC max.
Humidity Range:	10% to 93% RH.
Operating Temperature:	-22° F to 140° F (-30° C to 60° C).
Contact Ratings:	120 VAC: 0.5 A max. (resistive load). 30 VDC: 3 A max. (resistive load).
Wire Length:	8" minimum.

Agency Listings and Approvals

In some cases, certain modules may not be listed by certain approval agencies, or listing may be in process. Consult factory for latest listing status.

- UL/ULC Listed: S3705
- ULC Listed: CS669
- MEA: 419-04-E
- CSFM: 7300-1653:173

PRODUCT LINE INFORMATION

NOTE: "A" suffix indicates ULC listed model.

PR-1(A): Epoxy encapsulated single pull double throw (SPDT) relay. It also uses a red LED as a visible indication of relay coil energization with pigtailed.

PR-2(A): Epoxy encapsulated single pull double throw (SPDT) activated by 10 to 40 VDC. It uses a red LED as a visible indication of relay coil energization with pigtailed.

PR-3(A): Epoxy encapsulated single pull double throw (SPDT) activated by 10 to 40 VDC. It contains an additional black and red wire for redundant power input with pigtailed.

EOLR-1(A): Epoxy encapsulated single pull single throw (SPST) normally open relay that is activated by 9 to 40 VDC. This relay can be used as an end of line device in fire alarm systems, e.g., to supervise power supplies.

R-10T(A): Single (SPDT) relay with a red activation LED.

R-14T(A): 4-gang (SPDT) relay with 4 red activation LEDs.

R-20T(A): Single (DPDT) relay with a red activation LED.

R-24T(A): 4-gang (DPDT) relay with 4 red activation LEDs.

The R-10E(A)/R-20E(A) and R-14E(A)/R-24E(A) are similar to the T series track mount relays, but they are mounted into a steel enclosure. The enclosure has a removable front cover that provides easy access and a LED viewing hole on the top of the cover.

R-10E(A): Single (SPDT) relay mounted into a steel enclosure, 1 red activation LED.

R-14E(A): 4-gang (SPDT) relay mounted into a steel enclosure, 4 red activation LEDs.

R-20E(A): Single (DPDT) relay mounted into a steel enclosure, 1 red activation LED.

R-24E(A): 4-gang (DPDT) relay mounted into a steel enclosure, 4 red activation LEDs.



7015pr1.jpg

PR-1(A)



7015pr2.jpg

PR-2(A)



7015pr3.jpg

PR-3(A)

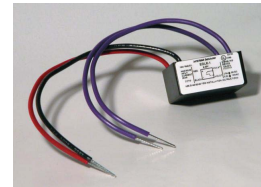

7015eolr1.jpg

EOLR-1(A)



7015r10t.jpg

R-10T(A)

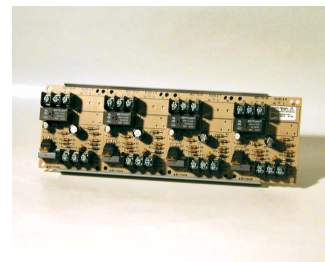

7015r14t.jpg

R-14T(A)

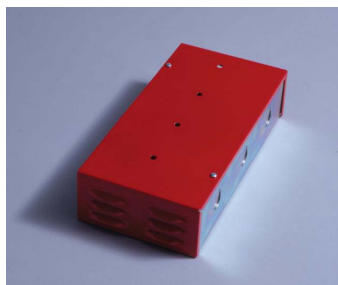

7015r20-24e.jpg

**R-20E(A) & R-24E(A)
Enclosures**

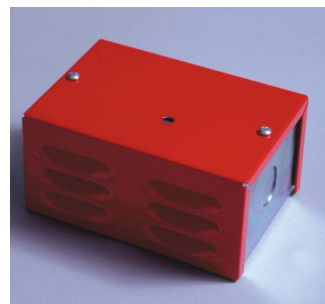

7015r10-14e.jpg

**R-10E(A) & R-14E(A)
Enclosures**

©2013 by Honeywell International Inc. All rights reserved. Unauthorized use of this document is strictly prohibited.



This document is not intended to be used for installation purposes.
We try to keep our product information up-to-date and accurate.
We cannot cover all specific applications or anticipate all requirements.
All specifications are subject to change without notice.

For more information, contact Notifier. Phone: (203) 484-7161, FAX: (203) 484-7118.
www.notifier.com

7788F/7744F Series

Wireless Fire Alarm Communicators for AES-IntelliNet

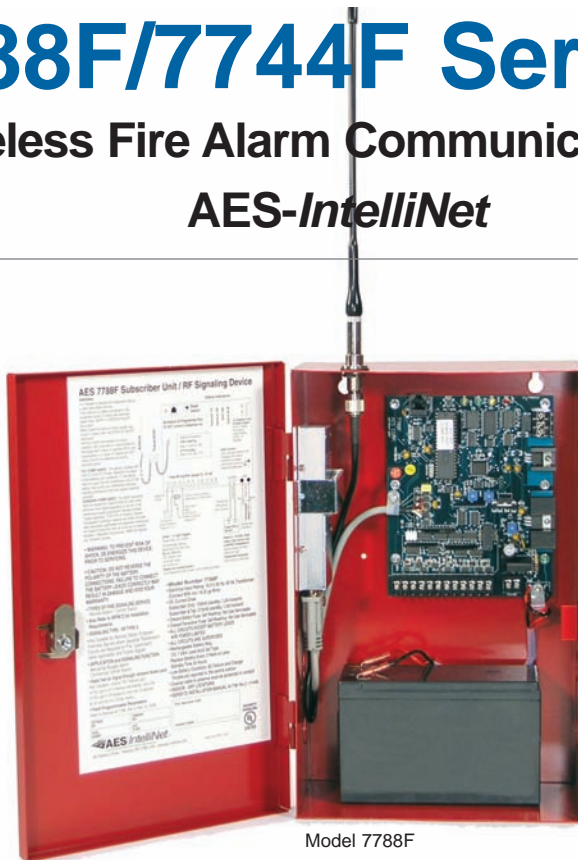

Features – All models

- UL Listed commercial fire alarm applications.
- Meets NFPA 72 requirements
- Direct reporting to AES receiver across IntelliNet wireless mesh network
- Each Subscriber acts as transmitter/receiver/repeater
- Simple and fast activation on network
- On board status LEDs for easy set up
- 8 programmable zone inputs – 7788F
- 4 programmable zone inputs and 4 reverse polarity inputs – 7744F
- Easy programming via AES handheld programmer or PC
- Rugged metal housing ideal for any commercial fire alarm application

Models 7788F/7744F-ULP with IntelliPro Fire also includes

- IntelliPro Fire transmits full alarm data from virtually any fire alarm panel digital communicator
- Alarm format support for Contact ID, Pulse, or Bosch Modem IIe or Modem IIIa2
- Easy installation in AES subscriber
- Operates in applications with or without a phone line

Advanced Wireless Alarm Monitoring

The AES-IntelliNet mesh radio network offers unmatched reliability and speed in delivering wireless alarm signals to a central station without third party fees or reliance on networks owned by companies outside the security and fire alarm industry. AES-7788F/7744F Series Smart Subscriber Transceivers provide the wireless communication link between the fire alarm panel and the central station receiver. The 7788F/7744F Series is ideal for most commercial fire alarm applications. Each 7788F/7744F Series Subscriber is housed in a full sized, red, locked, steel cabinet and supports a range of alarm panel inputs including EOL fire, EOL supervised, and direct voltage from the panel (non-fire applications).

Supervised Operation

AES Smart Subscribers offer fully supervised operation that includes monitoring of operating power (both primary AC power and battery backup) and the connection to the radio network. Each Subscriber “checks in” with the AES central station receiver at least once every 24 hours. The supervision check in time can be set for as often as once per minute and, because the central station owns the wireless network, there is no additional cost for air time to transmit supervisory signals.

Full Data Reporting from Alarm Panel Digital Dialer

Models 7788F-ULP and 7744F-ULP come equipped with an IntelliPro Fire Full Data Module (AES-7794) which enables reporting of full alarm data captured from the fire alarm panel's digital communicator. IntelliPro Fire supports most alarm communication formats including Contact ID, Pulse, as well as Bosch Modem IIe and Modem IIIa2.



Wireless mesh networking is an innovative technology adopted by many industries with applications that need to communicate data over a large geographic area with a high level of reliability at a low total cost of ownership.

The advanced design and 2-way communications capability provides easy installation, expansion, and management when compared to alternative communication methods, both wired and wireless.

7788F/7744F Series



Technical Specifications

7788F/7744F Series Subscribers

Dimensions

- 13.25"H x 8.5"W x 4.3"D
(34cm H x 21.5cm W x 11cm D)

Weight

- Approx. 7 pounds (3.2 kilograms),
excludes battery.

Radio Frequency

- Standard Frequency Range:
450-470MHz (others available)
- Output Power - 2 Watts
(others available)

Antenna

- Included 2.5 db tamper resistant
antenna mounts on enclosure
- Multiple remote antenna options
available

Power Input

- 16.5VAC, 40VA (transformer not
included)

Backup Battery

- Will charge 12V battery up to 7.5 AH.
Requires 12VDC 7.5 AH battery for
UL 864.

Alarm Signal Inputs (subscriber)

- 7788F – 8 individually programmable
zones
- 7744F - 4 individually programmable
zones and 4 reverse polarity inputs

UL Standards

- UL 864 Edition 9 – Standard for
Control Units and Accessories for Fire
Alarm Systems
- UL 365 – Standard for Police Station
Connected Burglar Alarm Units and
Systems
- UL 1681 – Standard for Central
Station Burglar Alarm Units

Antenna Cut / Communication

Trouble Output

- Form C relay; fail secure; rated for 24
VDC 1A resistive

Reset Button

- Located on main circuit board.

Operating Temperature

- 0° to 50° C (32° to 122°F)

Storage Temperature

- -10° to 60° C (14° to 140°F)

Relative Humidity

- 0 to 85% RHC, Non Condensing

AES-7794 IntelliPro Fire

Input / Output Connections

- RJ11 connection to AES subscriber for
module data and power
- RJ11 connector for Handheld
Programmer/PC programming
- RJ31X Telco connections - T and R
both in and out via terminal strip and
RJ45
- Alarm Panel digital communicator
T and R both in and out via terminal
strip and RJ45
- Trouble output: Form C relay detects if
Subscriber is off the network

Alarm Formats

- Support for Contact ID and Pulse
formats as well as Modem IIe and
Modem IIIa2 converted to CID

Size

- 2.8 x 5.0 inches (7.1cm x 12.7cm)

Power Requirements

- 12 VDC nominal - primary and backup
power provided by the AES
7788F/7744F or other Subscriber

How to Order

Model	Description
7744F	4 Zone Fire Alarm Subscriber with 4 reverse polarity inputs
7744F-ULP	7744F Fire Alarm Subscriber with IntelliPro Fire full data module
7788F	8 Zone Fire Alarm Subscriber
7788F-ULP	7788F Fire Alarm Subscriber with IntelliPro Fire full data module

Optional Accessories

7041E	Subscriber Handheld Programmer
7794	IntelliPro Fire Full Data Module



AES-IntelliNet™ is the industry leader in delivering high quality wireless mesh networks to the fire and security industry in commercial, corporate, government, and educational applications with its broad line of products and advanced network management tools. Users of AES-IntelliNet networks have gained significant revenue, communications, and cost advantages while meeting the high standards of reliability required for the fire and security industry. AES-IntelliNet alarm monitoring systems are deployed at hundreds of thousands of locations in over 150 countries.



For more information

Call 800-AES-NETS (800-237-6387)

AES Corporation | 285 Newbury Street | Peabody, MA 01960 USA

Tel. +1 978-535-7310 | Fax +1 978-535-7313 | Email info@aes-intellinet.com

Web www.aes-intellinet.com

Copyright 2011 AES Corporation
AES-IntelliNet is a registered trademark
of AES Corporation

7788F-7744F/9/7/11R3

**NO
EXCUSES!**

SIGNALING



SYSTEM RECORD DOCUMENTS

The SRD is the perfect item to help you meet demanding code requirements today. NFPA 72 2013 7.7.2.4 states that a cabinet must be "prominently labelled 'SYSTEM RECORD DOCUMENTS'."

The SRD is the perfect fit to meet today's demanding code requirements. SAE's number one goal is to manufacture code compliant solutions and this product allows you to do just that. NFPA 72 2013 7.7.2.1 states, "With every new system, a documentation cabinet shall be installed at the system control unit or other approved location at the protected premises."

This durable 16 gauge steel enclosure with a solid piano hinge and key lock will keep all of your code required documents in one safe place. With a 4GB USB flash drive it stores your fire alarm software safe and secure eliminating the occurrences of the software not being on site when technicians arrive to service the system. Along with your fire alarm software you can store your test & inspection, service records, manuals & system records. Using a standard USB B connector you may also store your records electronically (See NFPA 72 2013 7.5.6.7).

The SRD has designated hooks to organize key rings and hold important business cards for easy access and reference. Inside the cover it has an organized record for identifying equipment information, required documentation locations (See NFPA 72 2013 7.2.1).

Standard Features:

- Installed with a 4 GB digital flash drive with USB B connector
- 2 key ring hooks to hold system keys
- Business card holder for key contacts
- Overall dimensions are 12" x 13" tall and 2 1/4" deep
- 18 gauge steel box and cover for security
- Durable powder coat baked on finish other colors available
- Standard 3/4" cat 30 key lock. Other lock assemblies available
- Solid stainless steel piano hinge
- Permanently screened white ink 1" high "SYSTEM RECORD DOCUMENTS"
- Legend sheet for documentation, passwords and system information



**ISO 9001
REGISTERED
COMPANY**

ACEBOX

Space Age Electronics, Inc.
www.1sae.com
800.486.1723 Toll Free
508.485.0966 Local
508.485.4740 Fax

Specifications:

The system record documents box (SRD) shall be UL Listed, constructed of 18 gauge cold rolled steel. It shall have a red powder coat epoxy finish. The cover shall be permanently screened with 1" high lettering "SYSTEM RECORD DOCUMENTS " with white indelible ink. The access door shall be locked with a 3/4" barrel lock and the hinge shall be a solid width 12" stainless steel piano hinge. The enclosure will supply 4 mounting holes. Inside the enclosure will accommodate standard 8 1/2 x 11 manuals and loose document records that will be protected within the enclosure. A legend sheet will be permanently attached to the door for system required documentation, key contacts and system information. The SRD will have securely mounted inside a minimum of 4 Gigabyte digital flash memory drive with a standard USB B connector for uploading and downloading information. The drive shall not be accessible without tools to any person whom gains access to the records. The enclosure shall also provide 2 key ring holders with a location to mount standard business type cards for key contact personnel.

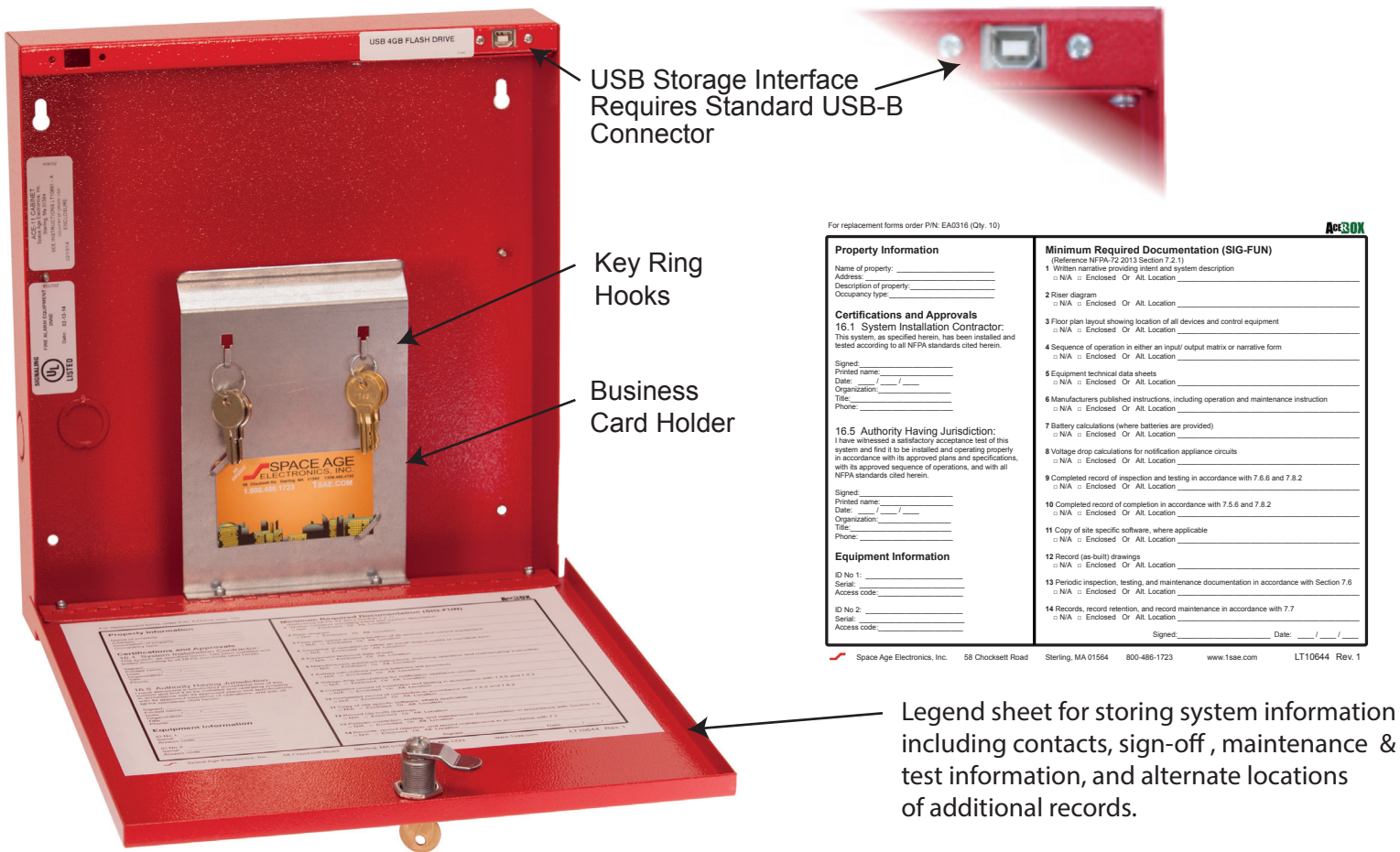

For replacement forms order PIN: EA0316 (Qty. 10)

Property Information	Minimum Required Documentation (SIG-FUN)
Name of property: _____	1 Written narrative providing intent and system description <input type="checkbox"/> N/A <input type="checkbox"/> Enclosed <input type="checkbox"/> All Location _____
Address: _____	2 Riser diagram <input type="checkbox"/> N/A <input type="checkbox"/> Enclosed <input type="checkbox"/> All Location _____
Description of property: _____	3 Floor plan layout showing location of all devices and control equipment <input type="checkbox"/> N/A <input type="checkbox"/> Enclosed <input type="checkbox"/> All Location _____
Occupancy type: _____	4 Sequence of operation in either an input/output matrix or narrative form <input type="checkbox"/> N/A <input type="checkbox"/> Enclosed <input type="checkbox"/> All Location _____
Certifications and Approvals	
16.1 System Installation Contractor: This system, as specified herein, has been installed and tested according to all NFPA standards cited herein.	
Signed: _____	5 Equipment technical data sheets <input type="checkbox"/> N/A <input type="checkbox"/> Enclosed <input type="checkbox"/> All Location _____
Printed name: _____	6 Manufacturers published instructions, including operation and maintenance instruction <input type="checkbox"/> N/A <input type="checkbox"/> Enclosed <input type="checkbox"/> All Location _____
Date: ____/____/____	7 Battery calculations (where batteries are provided) <input type="checkbox"/> N/A <input type="checkbox"/> Enclosed <input type="checkbox"/> All Location _____
Organization: _____	8 Voltage drop calculations for notification appliance circuits <input type="checkbox"/> N/A <input type="checkbox"/> Enclosed <input type="checkbox"/> All Location _____
Title: _____	9 Completed record of inspection and testing in accordance with 7.6.6 and 7.8.2 <input type="checkbox"/> N/A <input type="checkbox"/> Enclosed <input type="checkbox"/> All Location _____
Phone: _____	10 Completed record of completion in accordance with 7.5.6 and 7.8.2 <input type="checkbox"/> N/A <input type="checkbox"/> Enclosed <input type="checkbox"/> All Location _____
16.5 Authority Having Jurisdiction: I have witnessed a satisfactory acceptance test of this system and find it to be installed and operating properly in accordance with its approved plans and specifications, with its approved sequence of operations, and with all NFPA standards cited herein.	
Signed: _____	11 Copy of site specific software, where applicable <input type="checkbox"/> N/A <input type="checkbox"/> Enclosed <input type="checkbox"/> All Location _____
Printed name: _____	12 Record (as-built) drawings <input type="checkbox"/> N/A <input type="checkbox"/> Enclosed <input type="checkbox"/> All Location _____
Date: ____/____/____	13 Periodic inspection, testing, and maintenance documentation in accordance with Section 7.6 <input type="checkbox"/> N/A <input type="checkbox"/> Enclosed <input type="checkbox"/> All Location _____
Organization: _____	14 Records, record retention, and record maintenance in accordance with 7.7 <input type="checkbox"/> N/A <input type="checkbox"/> Enclosed <input type="checkbox"/> All Location _____
Title: _____	Signed: _____ Date: ____/____/____
Phone: _____	
Equipment Information	
ID No 1: _____	
Serial: _____	
Access code: _____	
ID No 2: _____	
Serial: _____	
Access code: _____	

Space Age Electronics, Inc. 58 Chocksett Road Sterling, MA 01564 800-486-1723 www.1sae.com LT10644 Rev. 1

Ordering Information:

Part #	Description
SSU00689	System Record Documents Cabinet RED
SSU00690	Custom screening with your Logo
EA0315	10 pack door legend sheet



Space Age Electronics, Inc.
www.1sae.com
800.486.1723 Toll Free
508.485.0966 Local
508.485.4740 Fax

This document is subject to change without notice, see doc # ED0479 for legal disclaimer

High Security Industrial/Government Key Vault

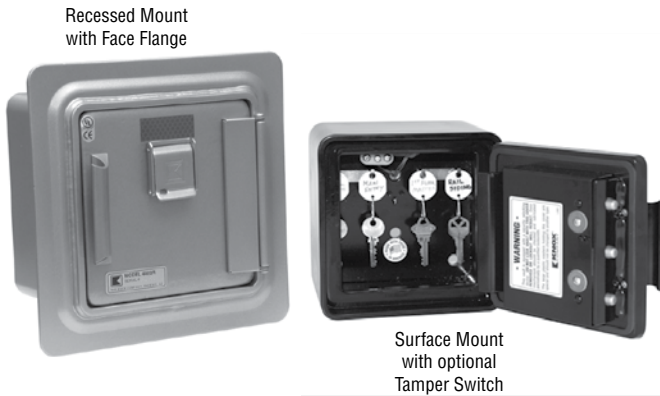

Knox-Vault™ key boxes are used in larger businesses, industrial properties, public buildings and universities. The heavy-duty, high security 4400 Series Knox-Vault protects and stores building keys, access cards and floor plans for emergency entry. The vault also provides secure storage for other internal and external applications.

Features and Benefits

- Holds up to 50 keys in the large interior compartment
- Ensures high security with UL® Listed Medeco lock(s)
- Includes Knox-Coat® that is four times better than standard powder coat
- Resists moist conditions with a weather resistant door gasket
- Colors: Black, Dark Bronze or Aluminum
- Weight: Surface mount - 28 lbs.
Recessed mount - 29 lbs.

Options

- Alarm tamper switches (UL Listed)
- Additional rust and corrosion protection (Aluminization)
- Recessed Mounting Kit (RMK) for recessed models only
- Custom vault depth available
- Dual lock configuration
- Inside switch for use on electrical doors, gates and other electrical equipment

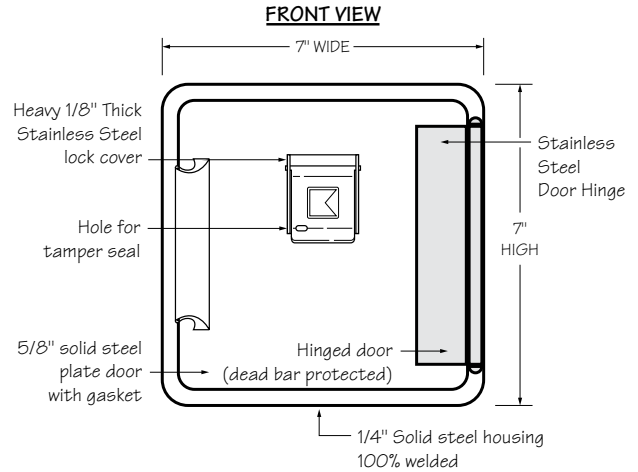

4400 Surface Mount

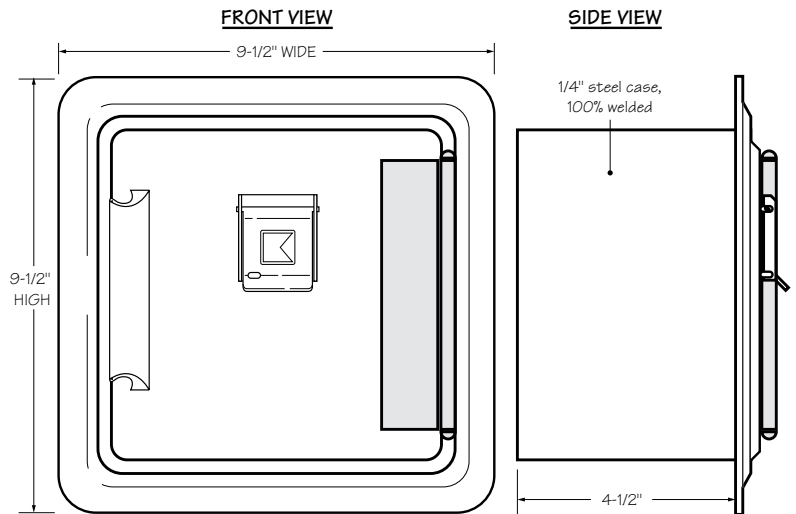

4400 Recessed Mount

Ordering Specifications

To insure procurement and delivery of the 4400 Series Knox-Vault, it is suggested that the following specification paragraph be used:

KNOX-VAULT surface/recessed mount, with/without UL Listed tamper switches. 1/4" plate steel housing, 5/8" thick steel door with interior gasket seal and stainless steel hinge. Vault and lock UL Listed. Lock has 1/8" thick stainless steel dust cover with tamper seal mounting capability. Vault has anti-theft re-locking mechanism with drill resistant hard-plate lock protector.

Exterior Dimensions: Surface mount - 7"H x 7"W x 5"D
Recessed mount flange - 9 1/2"H x 9 1/2"W

Lock: UL Listed. Double-action rotating tumblers and hardened steel pins accessed by a biased cut key.

Finish: Knox-Coat® proprietary finishing process
Finish Color - Black, Dark Bronze or Aluminum

P/N: 4400 Series Knox-Vault (mfr's cat. ID)

Mfr's Name: **KNOX COMPANY**

**Suggested minimum mounting height
6 feet above ground**

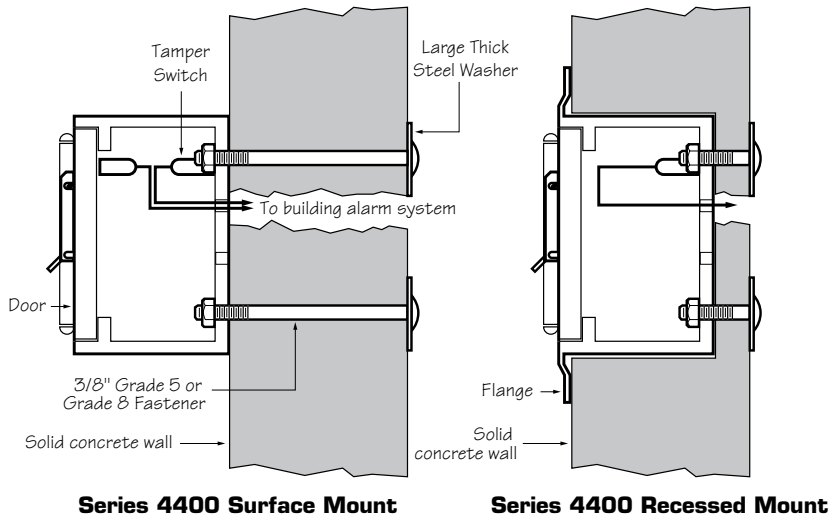

INSIDE VIEW

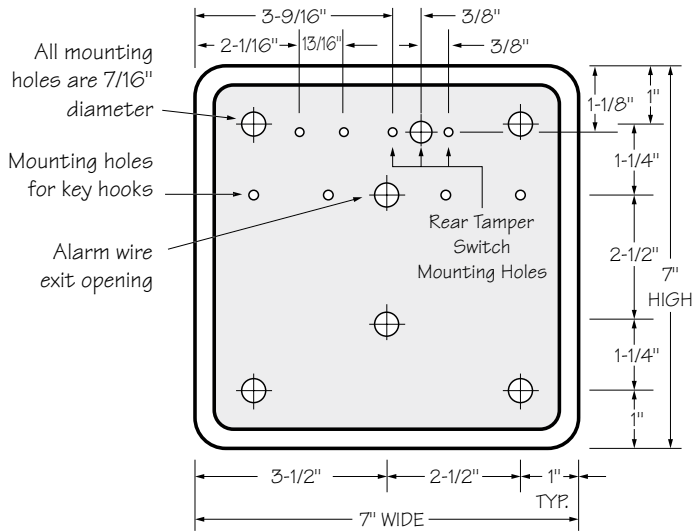

Attention: KNOX-VAULT™ is a very strong device that MUST be mounted properly to ensure maximum security and resist physical attack.

Knox® Rapid Entry System

The Knox Company manufactures a complete line of high security products including Knox-Box key boxes, key vaults, cabinets, key switches, padlocks, locking FDC caps, plugs and electronic master key security systems. For more information or technical assistance, please call Customer Service at 1-800-552-5669.

Recessed Mounting Kit

The 4400 Recessed Mounting Kit (RMK) is used for recessed models only. It contains a shell housing and mounting hardware to be cast-in-place in new concrete or masonry construction. After construction is completed, the Knox-Vault mounts inside the recessed shell housing. The RMK may only be used in new concrete or masonry construction.

Installation In Cast Concrete

The optional Recessed Mounting Kit is for use in new concrete or masonry construction only. The kit includes a shell housing and mounting hardware to be cast-in-place. The KNOX-VAULT is mounted into the shell housing after construction is completed.

Rough-In Dimensions

8 1/2"H x 8 1/2"W x 7"D

IMPORTANT: Care should be taken to insure that the front of the RMK shell housing, including the cover plate and screw heads, is flush with the finish wall. The RMK must be plumbed to insure vertical alignment of the vault.

Recessed Mounting Using Recessed Mounting Kit (RMK)

