

Door #	size	Mat	Rating	Hardware
101	3'-0"x7'-0"	HM		OFFICE LOCK

3 DOOR SCHEDULE
A1.01

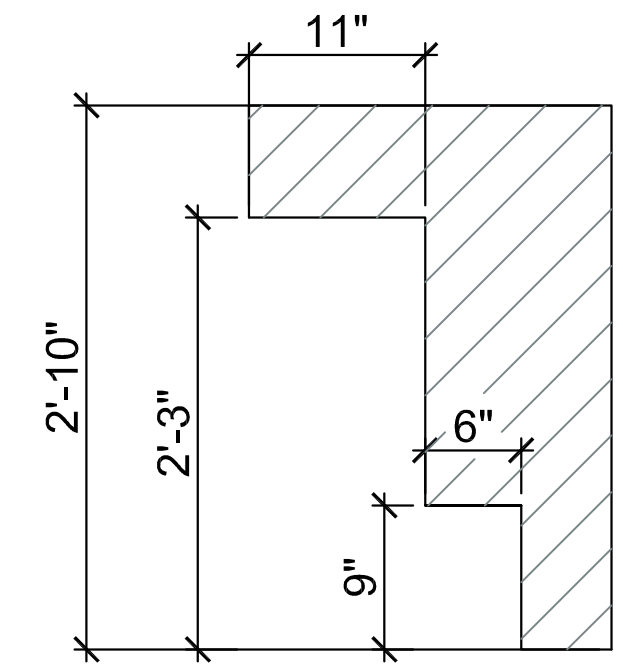

4 ADA COMPLIANT COUNTER
A1.01

1 FIRST FLOOR PLAN
A1.01 3/32" = 1'-0"

CODE ANALYSIS
 CONSTRUCTION TYPE 3B, SPRINKLED
 OCCUPANCY TYPE: B
 SQUARE FOOTAGE:
 560 S.F./200 = 2.8 OCCUPANTS
 3 OCCUPANTS
 UNIFORM PLUMBING CODE
 (TO USE COMMON BATHROOMS):
 MEN - 1 TOILETS, 0 URINAL, 1 LAV
 WOMEN - 1 TOILET, 1 LAV
 TRAVEL DISTANCES TO EGRESS
 LONGEST DISTANCE 40'+124'=164'
 PATH <300' W/ SPRINKLER
 COMMON PATH OF TRAVEL <100'
 W/ SPRINKLER

IBC 2009 TABLE 1004.1.1
 IBC 1016.1
 IBC 1014.3 EXCEPTION 1

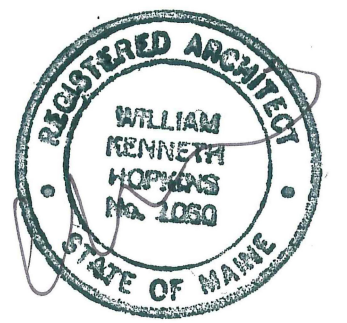

Prepared For:

Consultant:

Architect:

Project:

Revisions:

Date: 3-14-2016
 Scale: 1/8" = 1'-0"

PLAN & DETAILS &
 SCHEDULE

A1.01

ARCHETYPE
 48 Union Wharf Portland, Maine 04101
 (207) 772-6022 Fax (207) 772-4056

BRICK NORTH
 YETI KITCHEN
 THOMPSON'S POINT,
 PORTLAND ME