

1 MARKET 109 ISLAND: PLAN
Z3 SCALE: 1/2" = 1' - 0"

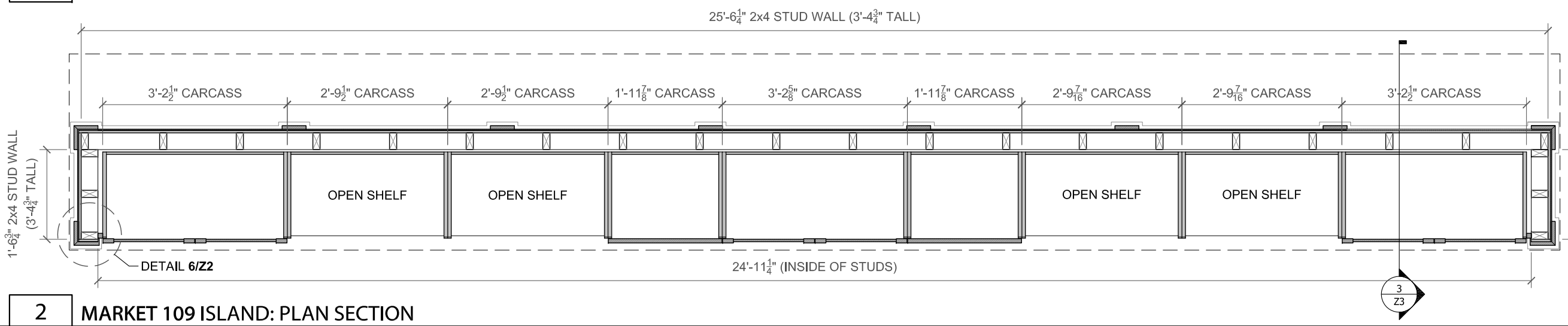

2 MARKET 109 ISLAND: PLAN SECTION
Z3 SCALE: 1/2" = 1' - 0"

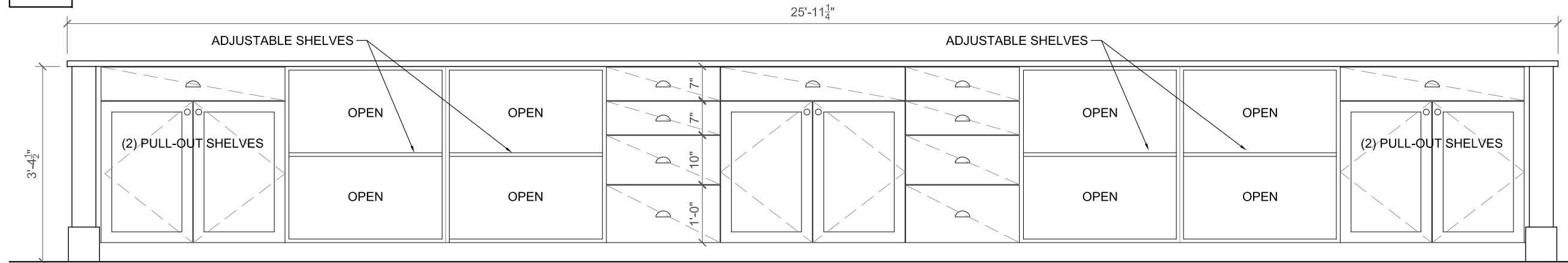

3 MARKET 109 ISLAND - SECTION
Z3 SCALE: 1" = 1' - 0"

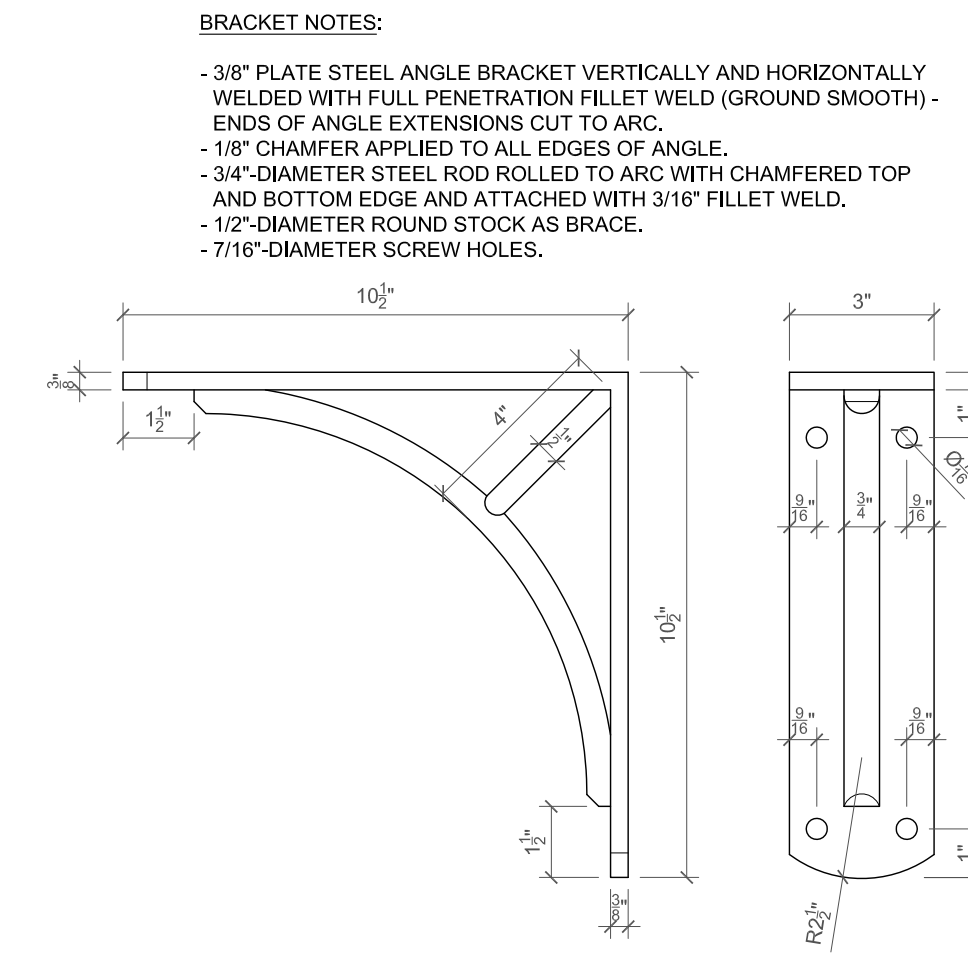

4 MARKET 109 ISLAND - SECTION
Z3 SCALE: 1" = 1' - 0"

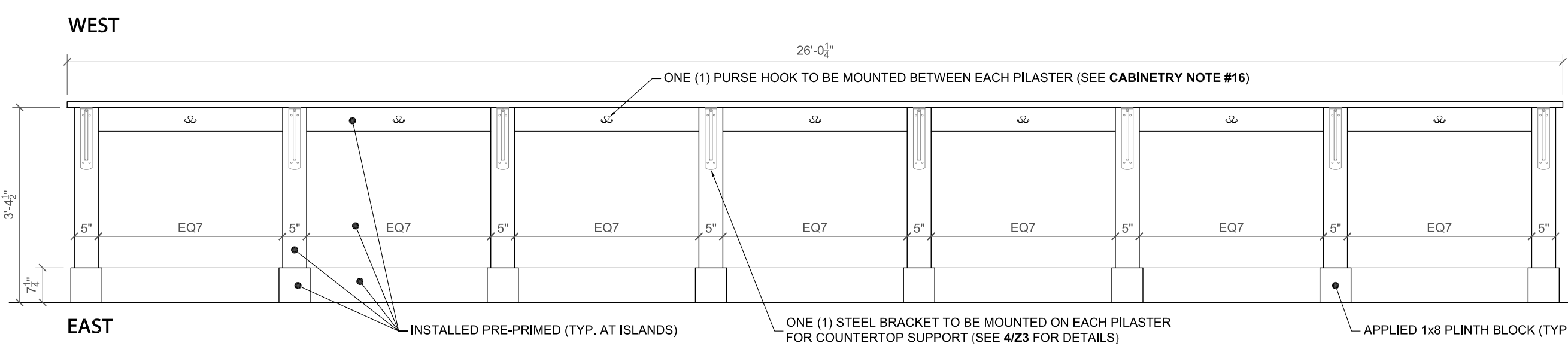

5 MARKET 109 ISLAND: ELEVATIONS
Z3 SCALE: 1/2" = 1' - 0"

CASEWORK SPECIFICATIONS:

DINING 101 BAR:
2x4 PONY-WALL SKINNED WITH PLYWOOD AND DETAILED AS DRAWN. FINISHED PAINTED
WORKING SIDE CABINERY DARK GRAY MELAMINE BOXES AND SHELVING, INCLUDING OPEN SHELVING

DINING 101 WALL CABINERY:
PREFINISHED PLYWOOD CABINERY BOXES AND INTERIOR SHELVING
OPEN SHELVING, UPPER DETAIL AND APPLIANCE SURROUNDS FINISH PAINTED

TASTING ROOM 108:
CABINERY BOXES AND OPEN SHELVING DARK GRAY MELAMINE
1/2 WALL 2x4 SKINNED WITH PLYWOOD AND DETAILED AS DRAWN, FINISHED PAINTED

BACK BAR 109 ISLAND:
CABINERY BOXES AND OPEN SHELVING DARK GRAY MELAMINE
1/2 WALL 2x4 SKINNED WITH PLYWOOD AND DETAILED AS DRAWN, FINISHED PAINTED

BACK BAR 109 WALL CABINERY:
PREFINISHED PLYWOOD CABINERY BOXES AND INTERIOR SHELVING
OPEN, UPPER DETAIL AND APPLIANCE SURROUNDS FINISH PAINTED

ALL CABINERY TO HAVE:
BAL TIC BIRCH PLYWOOD DRAWER BOXES CLEAR FINISHED
PAINTED DRAWERS AND DOOR FRONTS
SOFT CLOSE UNDER MOUNT DRAWER SLIDES
SOFT CLOSE CONCEALED HINGES
BLOCKING WILL BE IN PLACE FOR WALL MOUNTED CABINERY
5MM SHELF HOLES AND SHELF PINS IN ALL UPPER CABINETS WITH ONE SHELF
METAL BRACKETS ON 1/2 WALLS PROVIDED AND NEED TO BE INSTALLED
INSTALLATION OF ALL CABINERY AND 1/2 WALLS

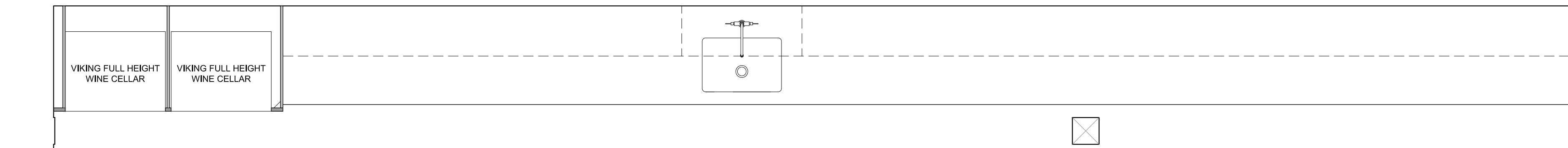

6 MARKET 109 WALL CABINERY: PLAN
Z3 SCALE: 1/2" = 1' - 0"



7 MARKET 109 WALL CABINERY: PLAN SECTION
Z3 SCALE: 1/2" = 1' - 0"

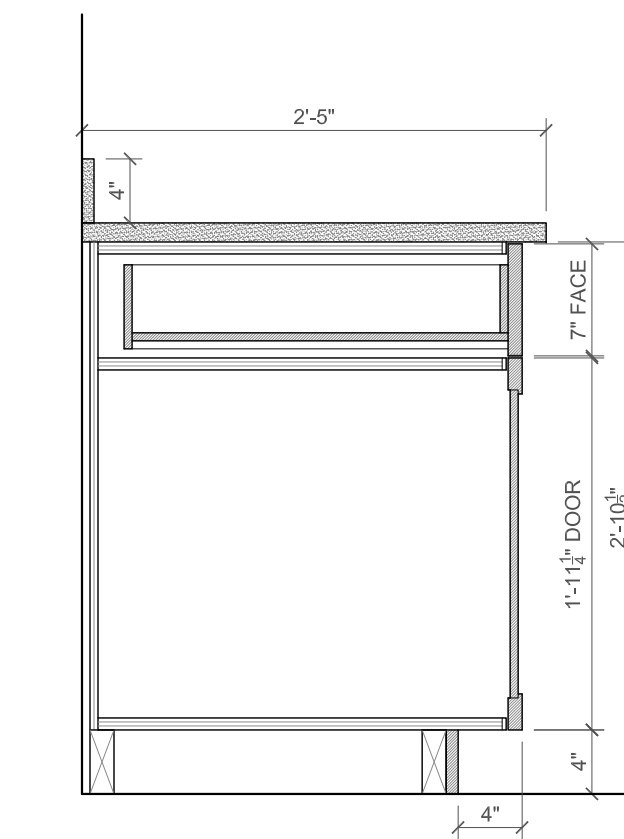

8 MARKET 109 BASE CABINERY - TYPICAL SECTION
Z3 SCALE: 1" = 1' - 0"

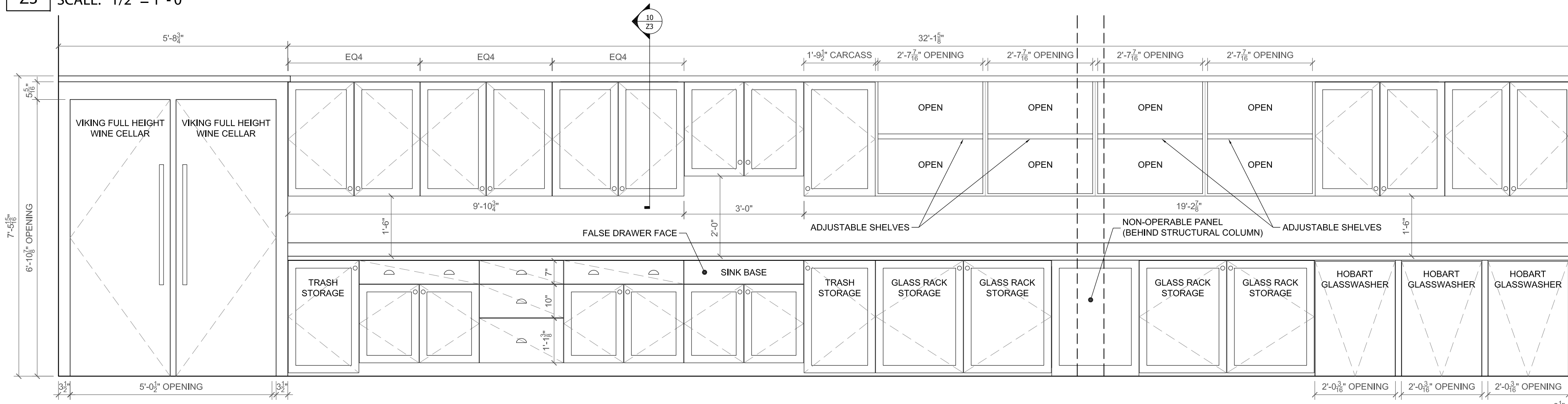

9 MARKET 109 WALL CABINERY: ELEVATION
Z3 SCALE: 1/2" = 1' - 0"

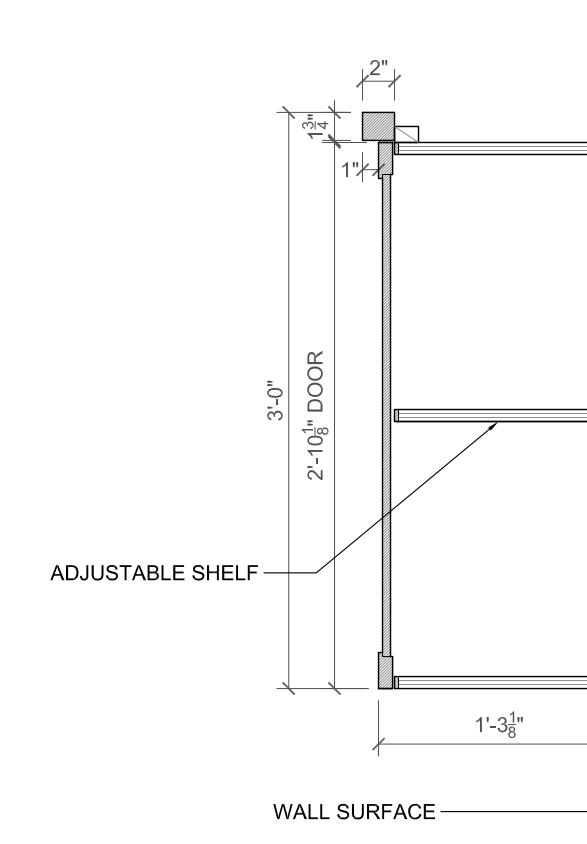

10 TYPICAL UPPER CABINET SECTION
Z3 SCALE: 1" = 1' - 0"

FOR REVIEW
ISSUED FOR PERMITTING NOT FOR CONSTRUCTION