

BASE PLATE TYPE "B-1"
(A.B. = 3/4"Ø, EMBED = 9")

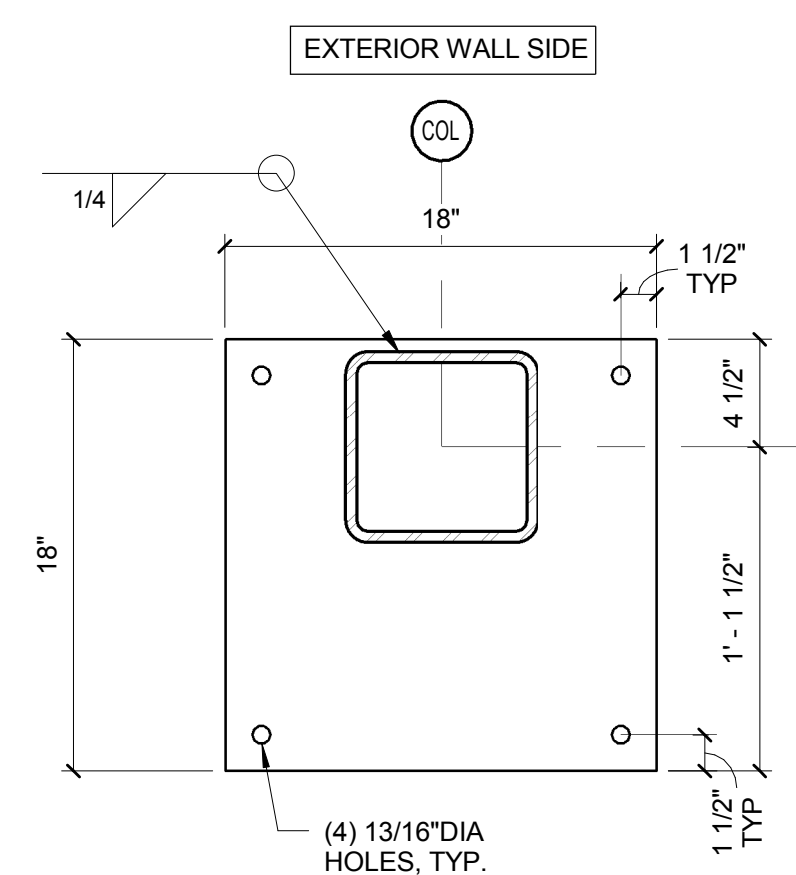

BASE PLATE TYPE "B-2"
(A.B. = 3/4"Ø, EMBED = 14")

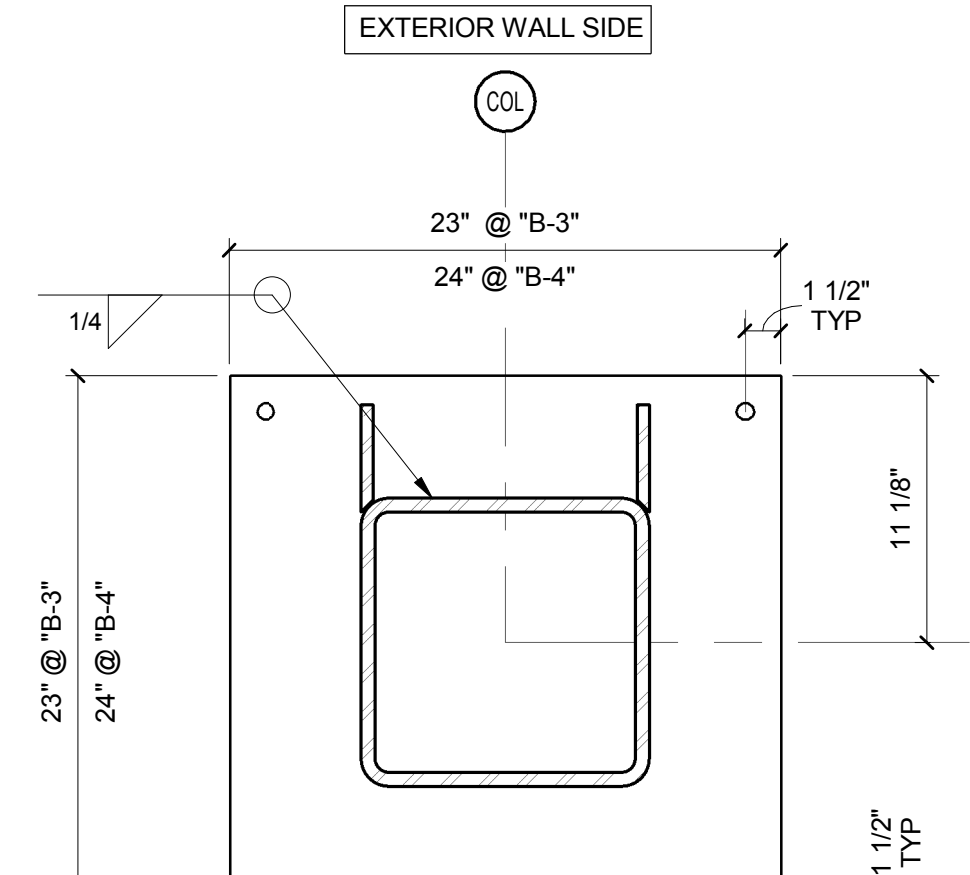

BASE PLATE TYPE "B-3" AND "B-4"
(A.B. = 3/4"Ø, EMBED = 14")

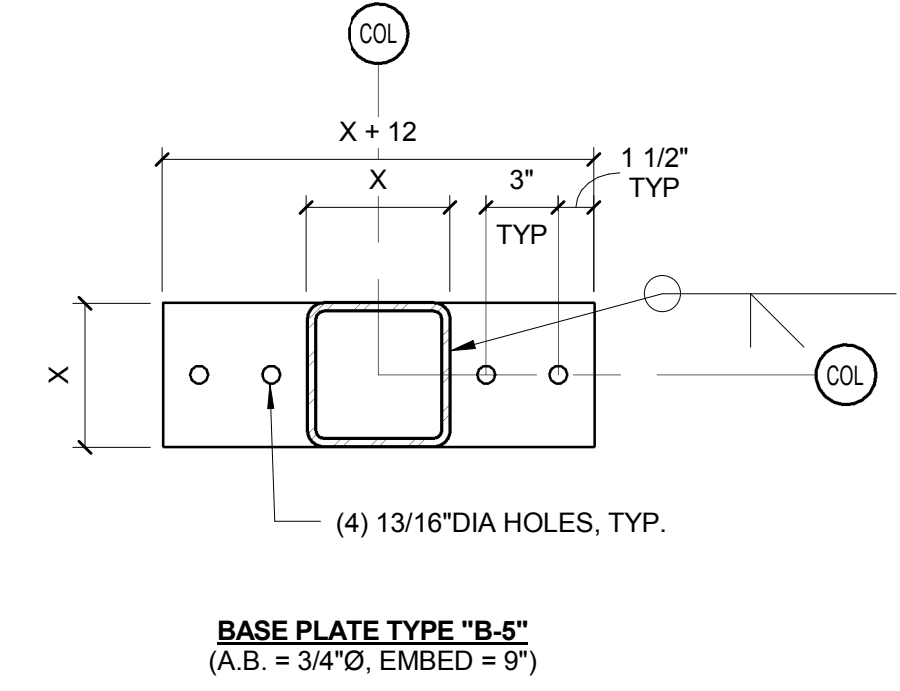

BASE PLATE TYPE "B-5"
(A.B. = 3/4"Ø, EMBED = 9")

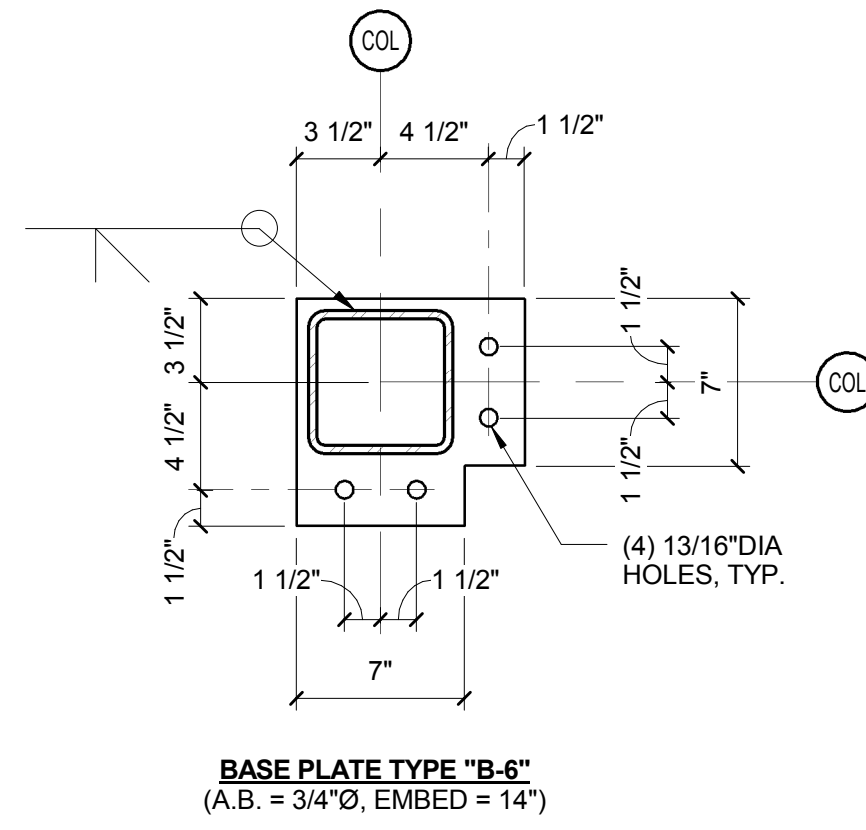

BASE PLATE TYPE "B-6"
(A.B. = 3/4"Ø, EMBED = 14")

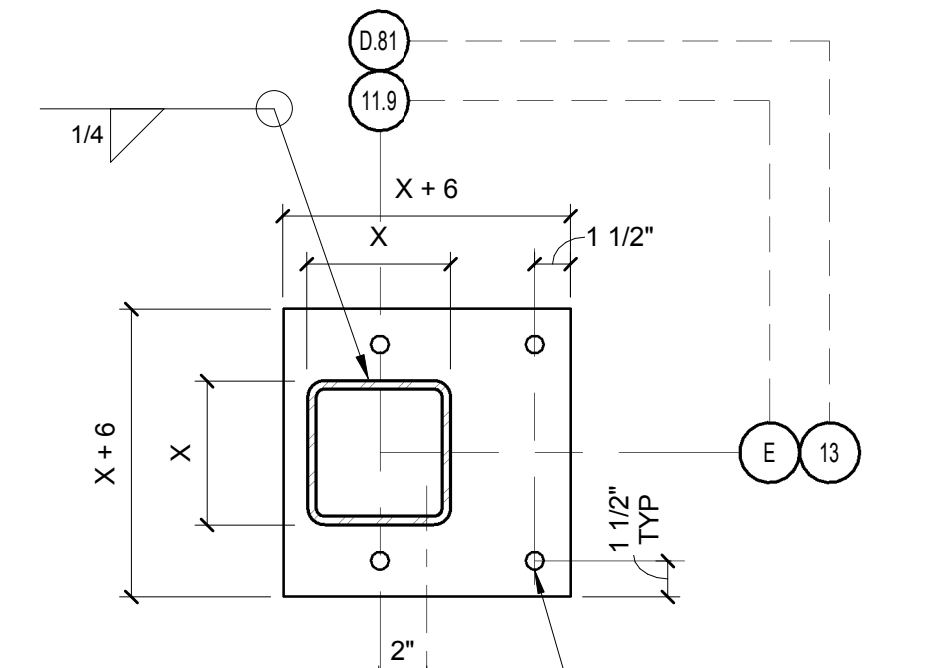

BASE PLATE TYPE "B-7"
(A.B. = 3/4"Ø, EMBED = 9")

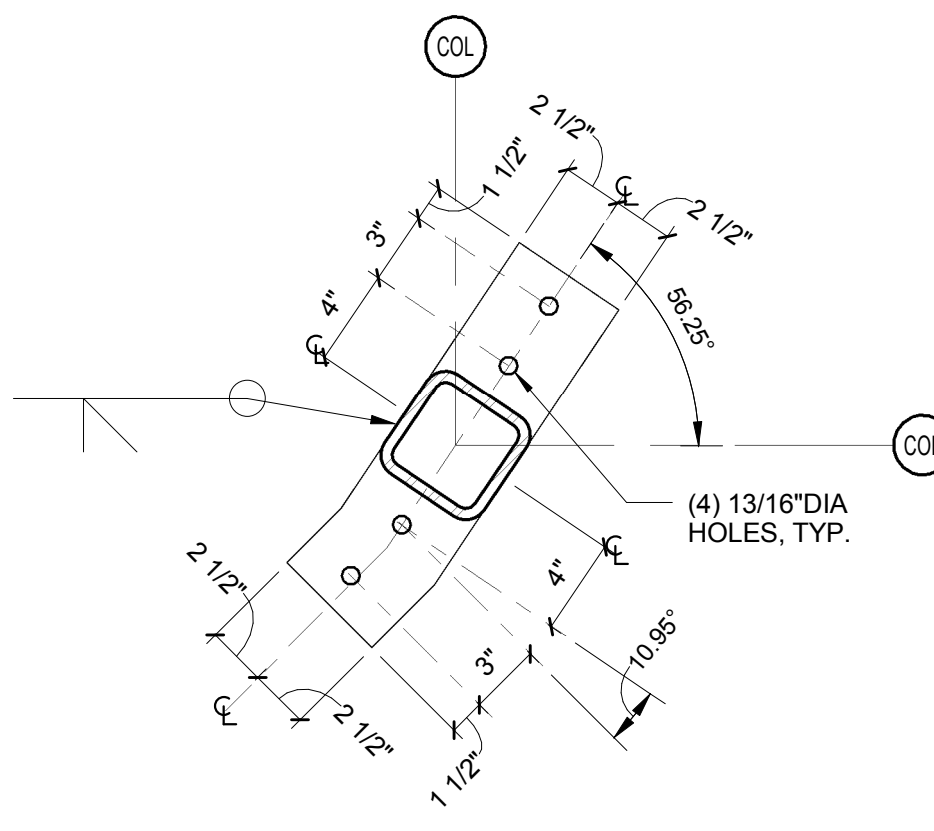

BASE PLATE TYPE "B-8"
(A.B. = 3/4"Ø, EMBED = 9")

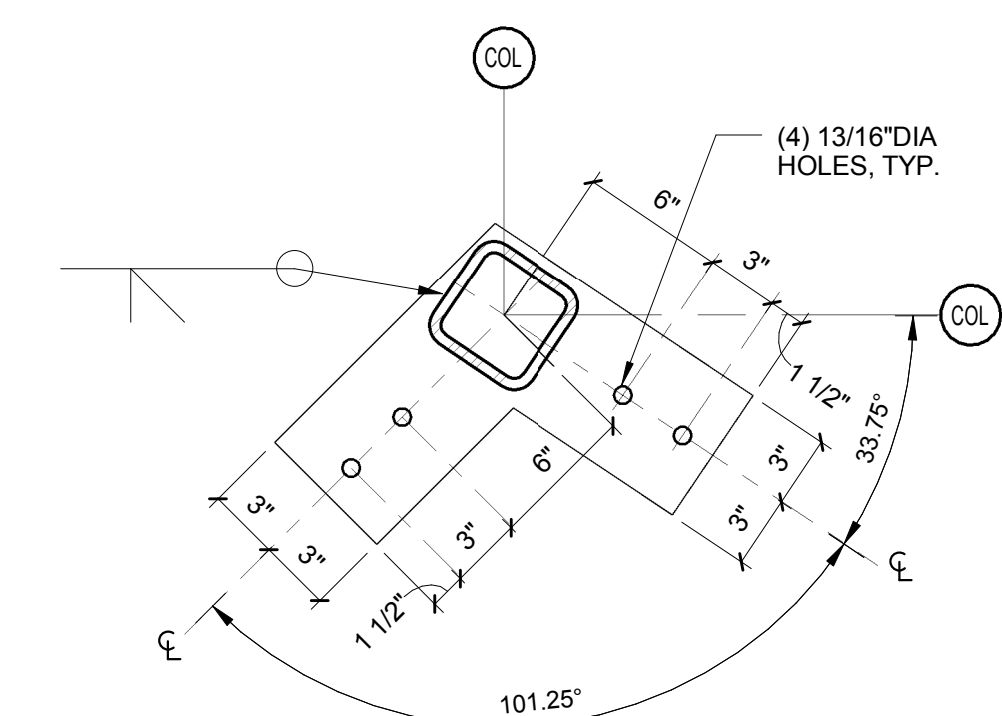

BASE PLATE TYPE "B-9"
(A.B. = 3/4"Ø, EMBED = 9")

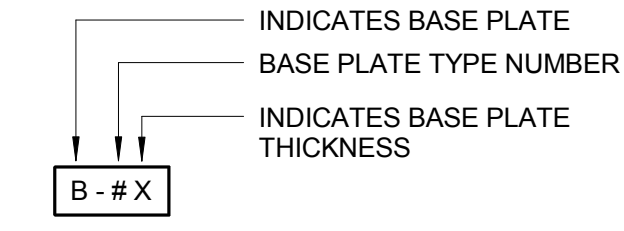

BASE PL MARKER LEGEND

BASE PLATE THICKNESS CHART:

- A = 1/2"
- B = 1"
- C = 1 1/2"
- D = 2"
- E = 2 1/2"
- F = 2 3/4"

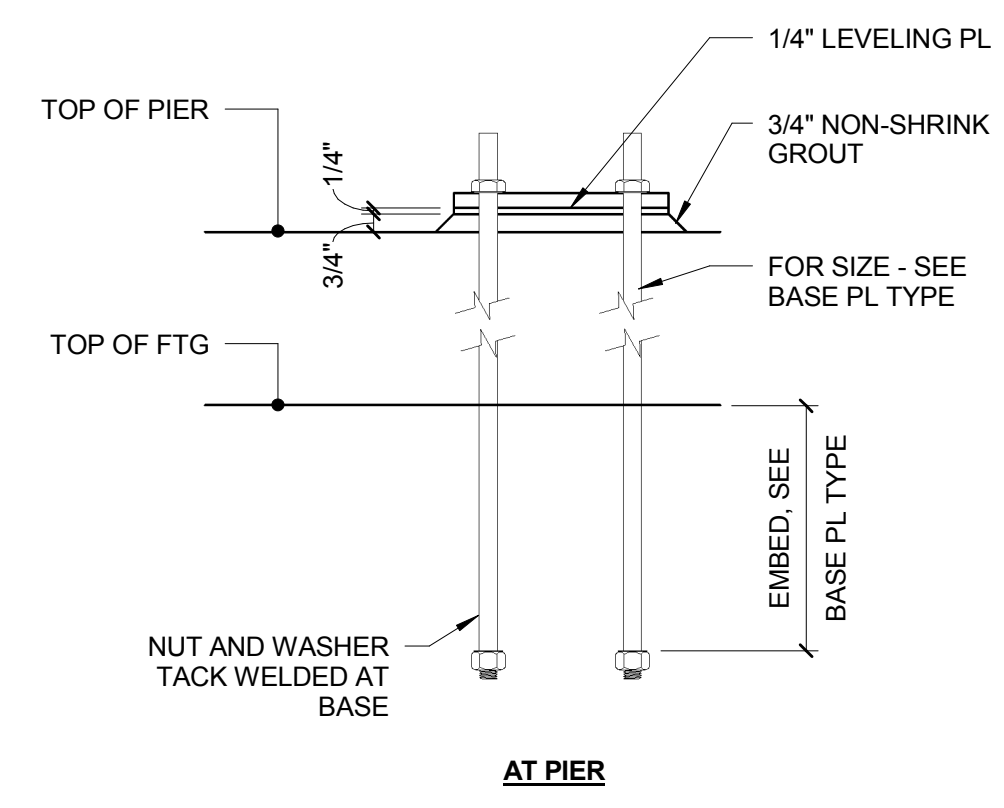

AT PIER

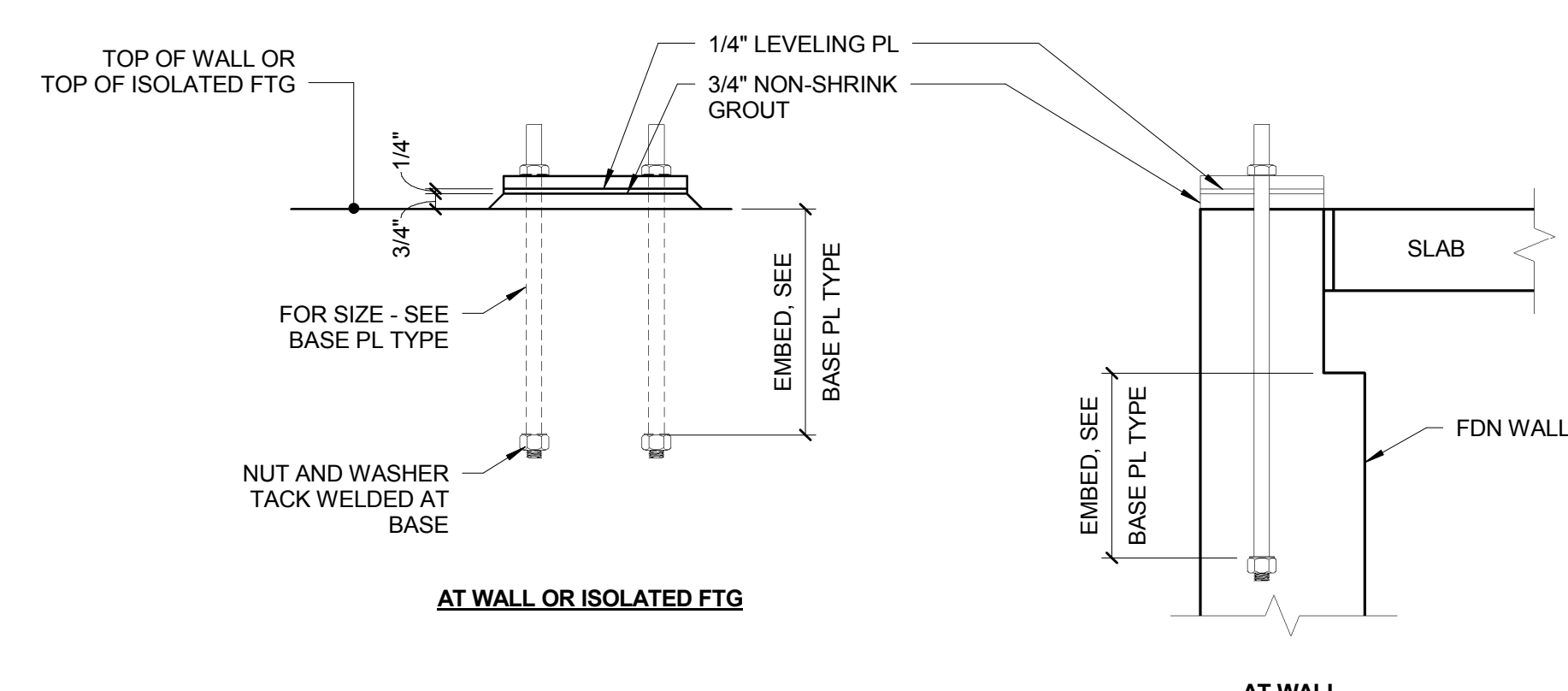

AT WALL OR ISOLATED FTG

AT WALL

D1 BASE PLATE TYPES

1 1/2" = 1'-0"

160 Veranda Street
Portland, Maine 04103
T: 207.221.2260
F: 207.221.2266
Web: www.allied-eng.com

Allied Engineering
Structural Mechanical Electrical Commissioning

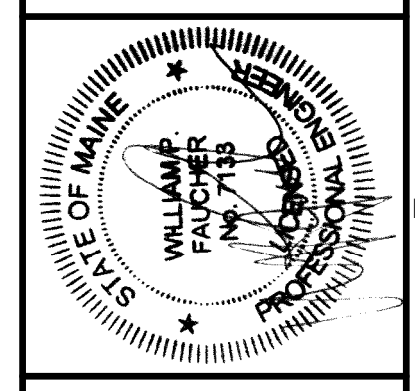

GRANT HAYS ASSOCIATES
ARCHITECTURE & INTERIOR DESIGN
P.O. BOX 6179 FALMOUTH MAINE 04105
207.871.9900 gha@granthays.com

Date:	01-27-2016
Drawn By:	PEB
Checked By:	JPM
Project Mgr.:	WPF
Project No.:	15028
Card File:	15028S.rvt
Graphic Scale:	0" = 1'

STRUCTURAL - BASE PLATE TYPES AND ENLARGED PLAN VIEWS

NFA NORTHEAST AIR
PORTLAND INTERNATIONAL AIRPORT
1011 WESTBROOK STREET PORTLAND, MAINE 04102

SB-200