

REV/NO/

DRAWING NAME

NEA
NORTH EAST AIR
PORTLAND INTERNATIONAL JETPORT
1011 W. BROOK STREET
PORTLAND, MAINE 04102

SHEET

PHASE I
INTERIOR
ELEVATIONS

DATE
19 FEB '16
SCALE
AS NOTED
DRAWN
MFH/mgk
JOB NO.
150655

SHEET
A17

COPYRIGHT
REPRODUCTION OR REUSE OF THIS
DOCUMENT WITHOUT WRITTEN
PERMISSION FROM GRANT HAYS
& ASSOCIATES IS PROHIBITED.

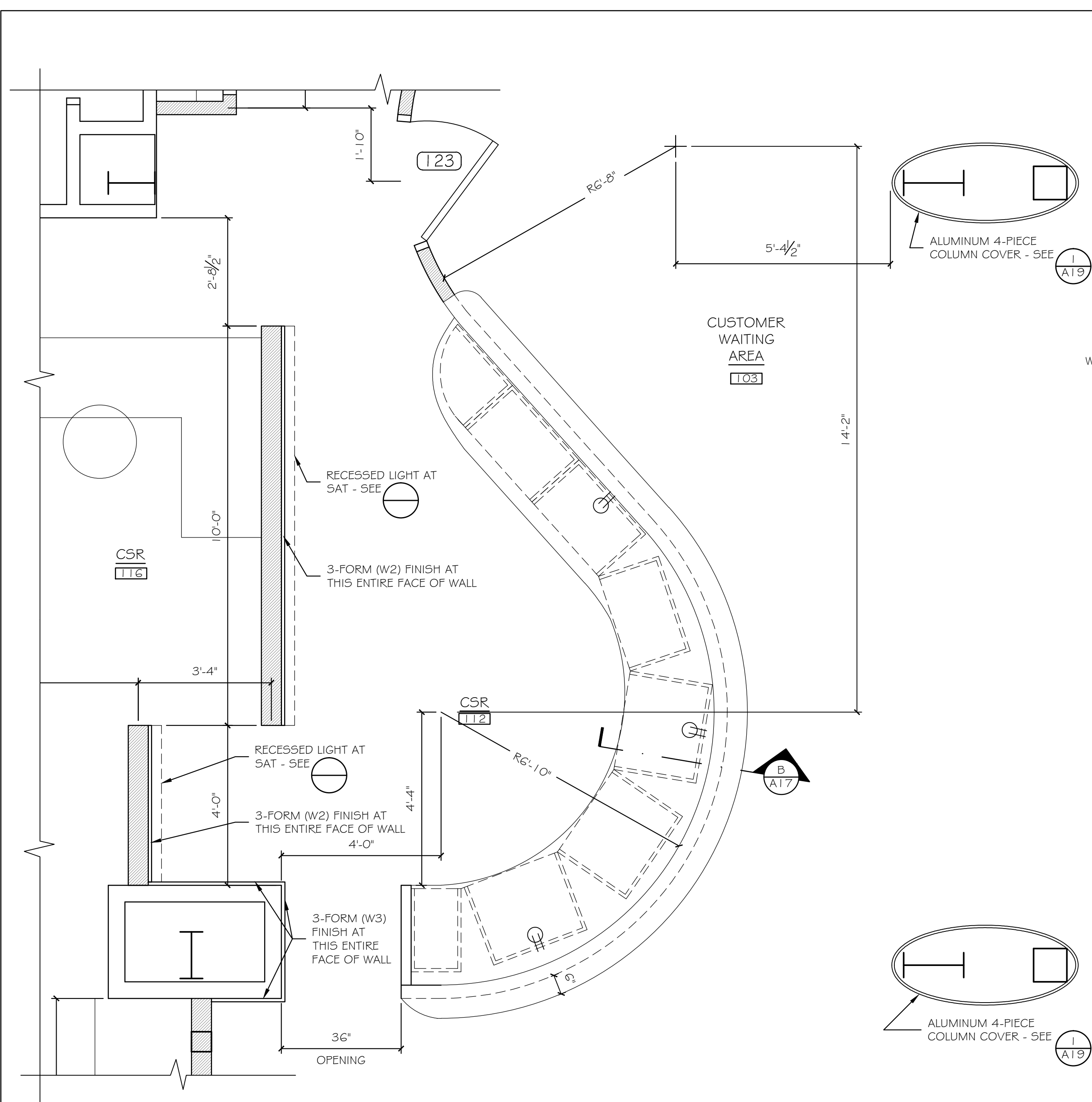

CSR 112 PLAN
SCALE: 1/2" = 1'-0"

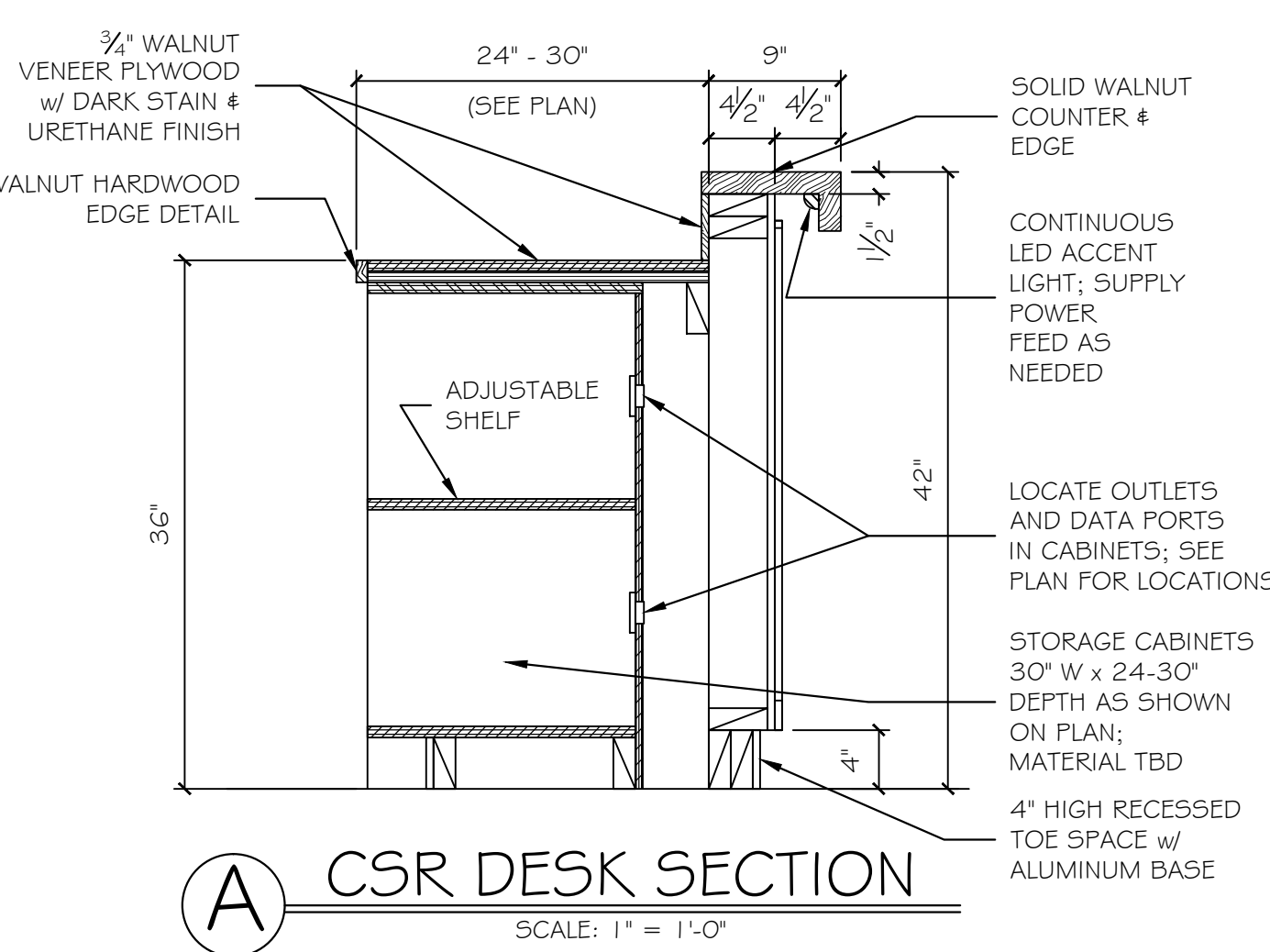

A CSR DESK SECTION
SCALE: 1" = 1'-0"

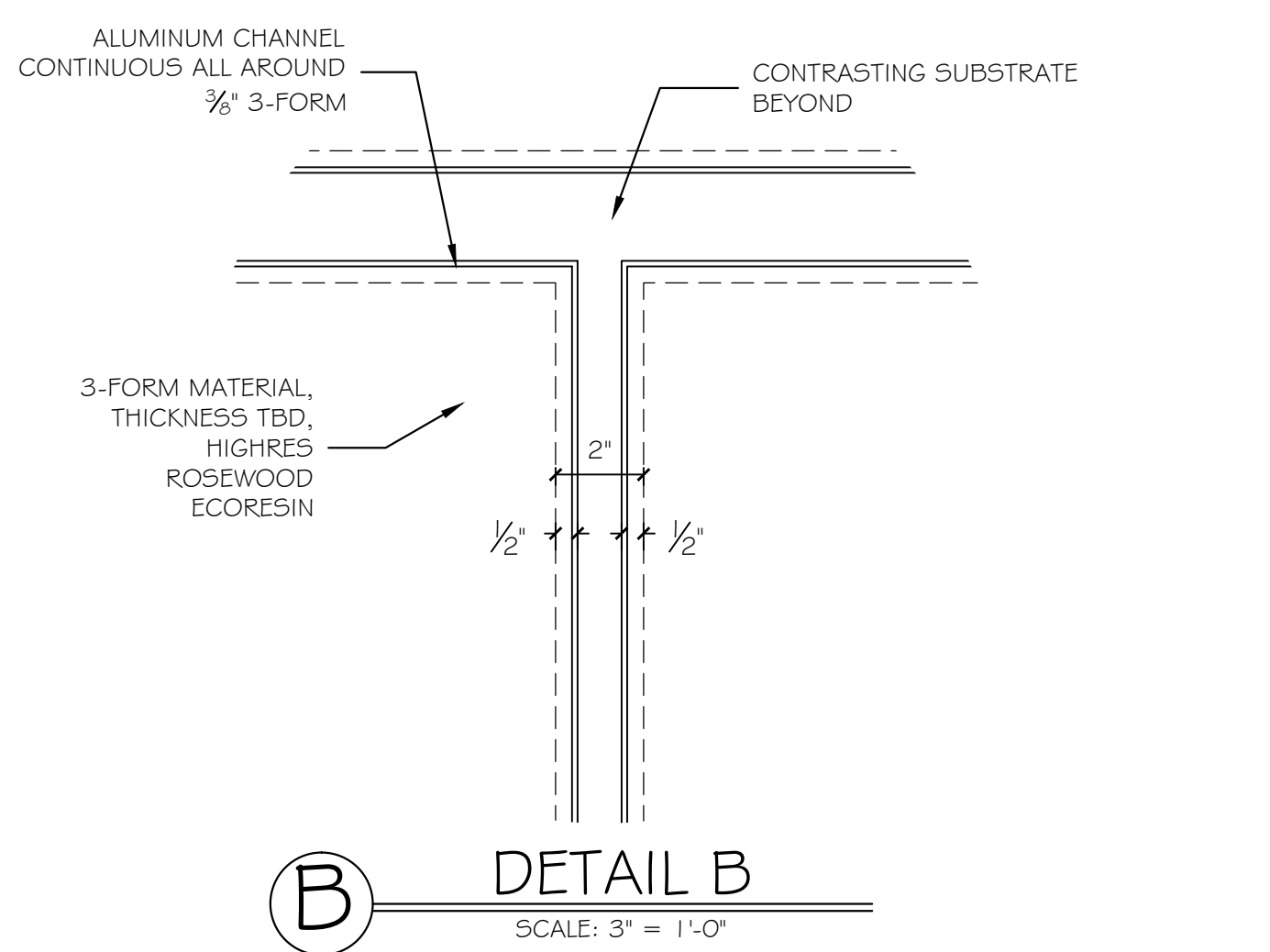

B DETAIL B
SCALE: 3" = 1'-0"

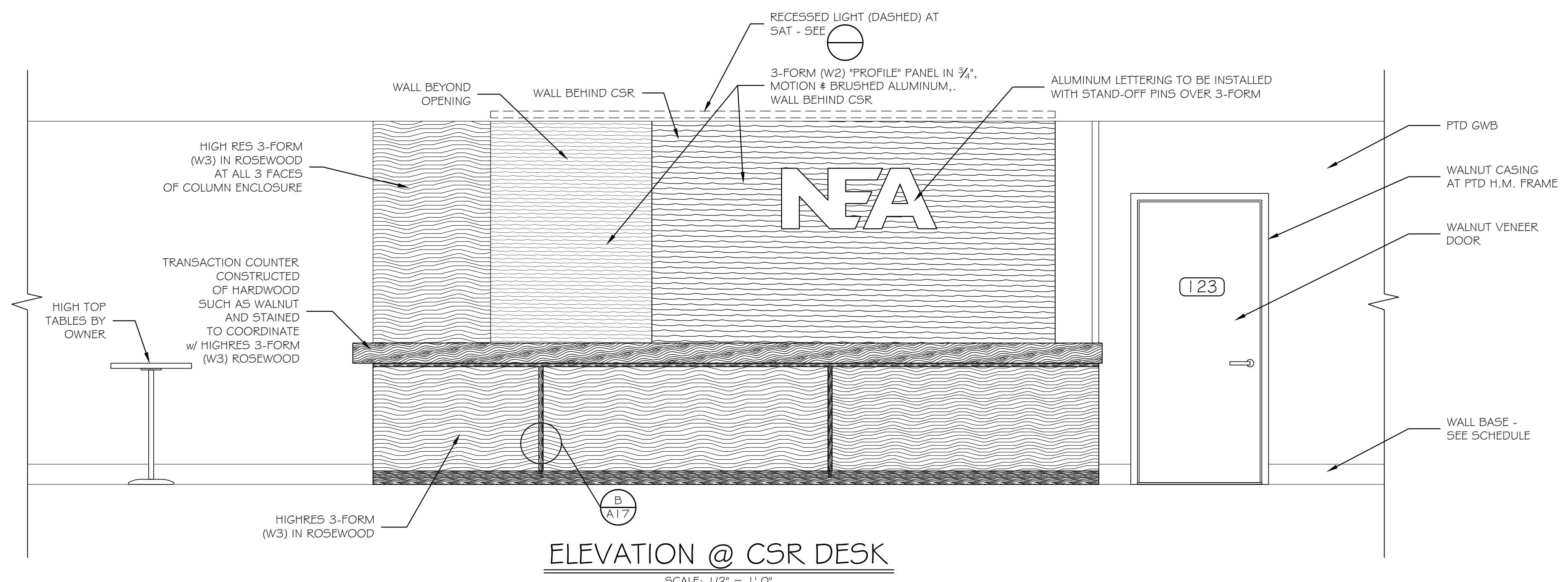

ELEVATION @ CSR DESK
SCALE: 1/2" = 1'-0"

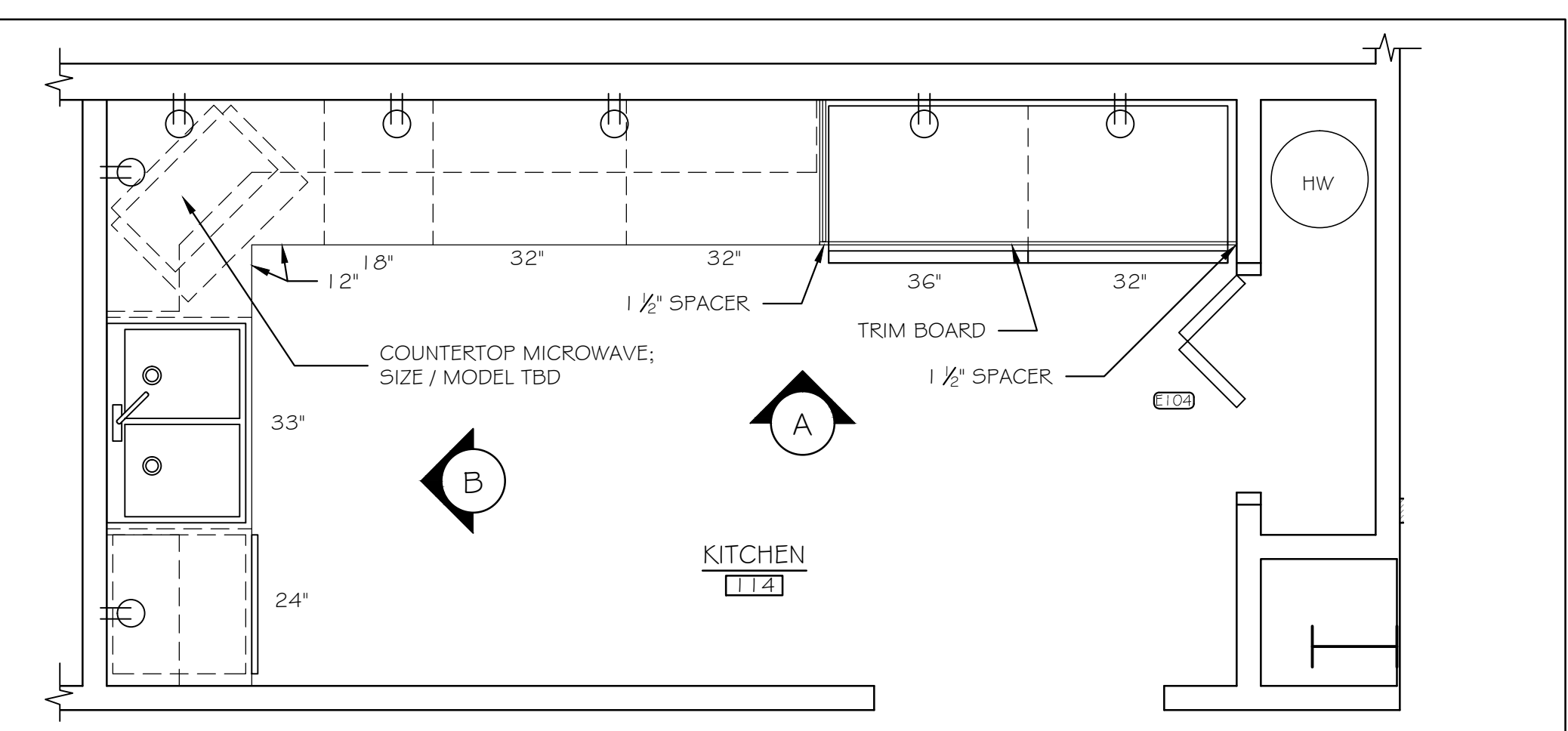

KITCHEN PLAN

APPLIANCES BY OWNER - MODELS MAY CHANGE (NO ICE MAKERS IN FREEZERS)

REFRIGERATOR: FRIGIDAIRE COMMERCIAL FREEZERLESS #FCR5181RQB 70 3/8" H x 32" W x 26 1/2" D

REFRIGERATOR / FREEZER: FRIGIDAIRE PROFESSIONAL FRENCH DOOR #FPBG2277RF 69 7/8" H x 36" W x 28 1/2" D

DISHWASHER: FISHER & PAYKEL #DD24DCTX7 DOUBLE DISH DRAWER

MICROWAVE: FRIGIDAIRE 2.2 cu. ft. COUNTERTOP MICROWAVE 24" W x 21 3/8" D x 13 1/8" H

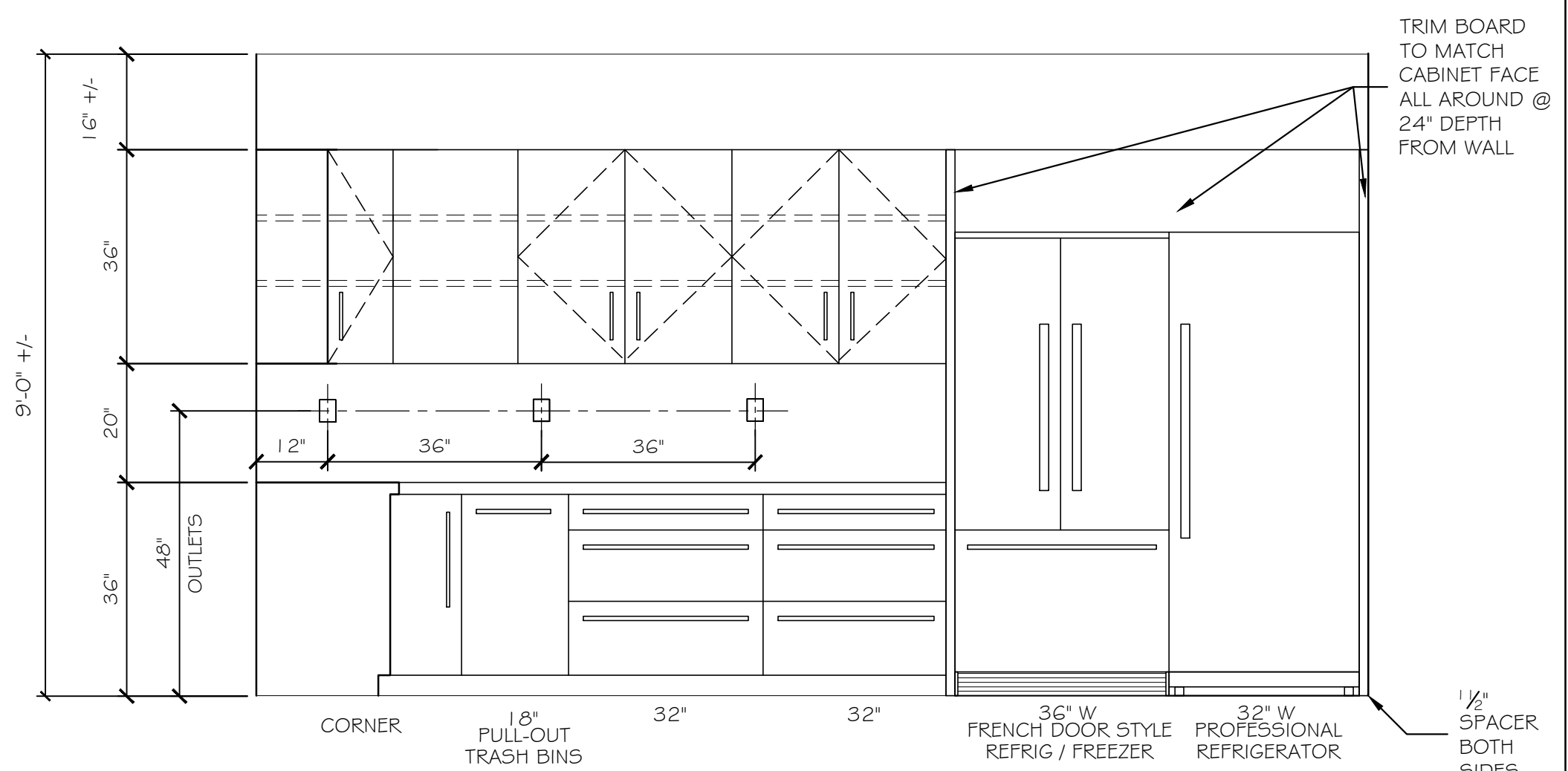

A ELEVATION A

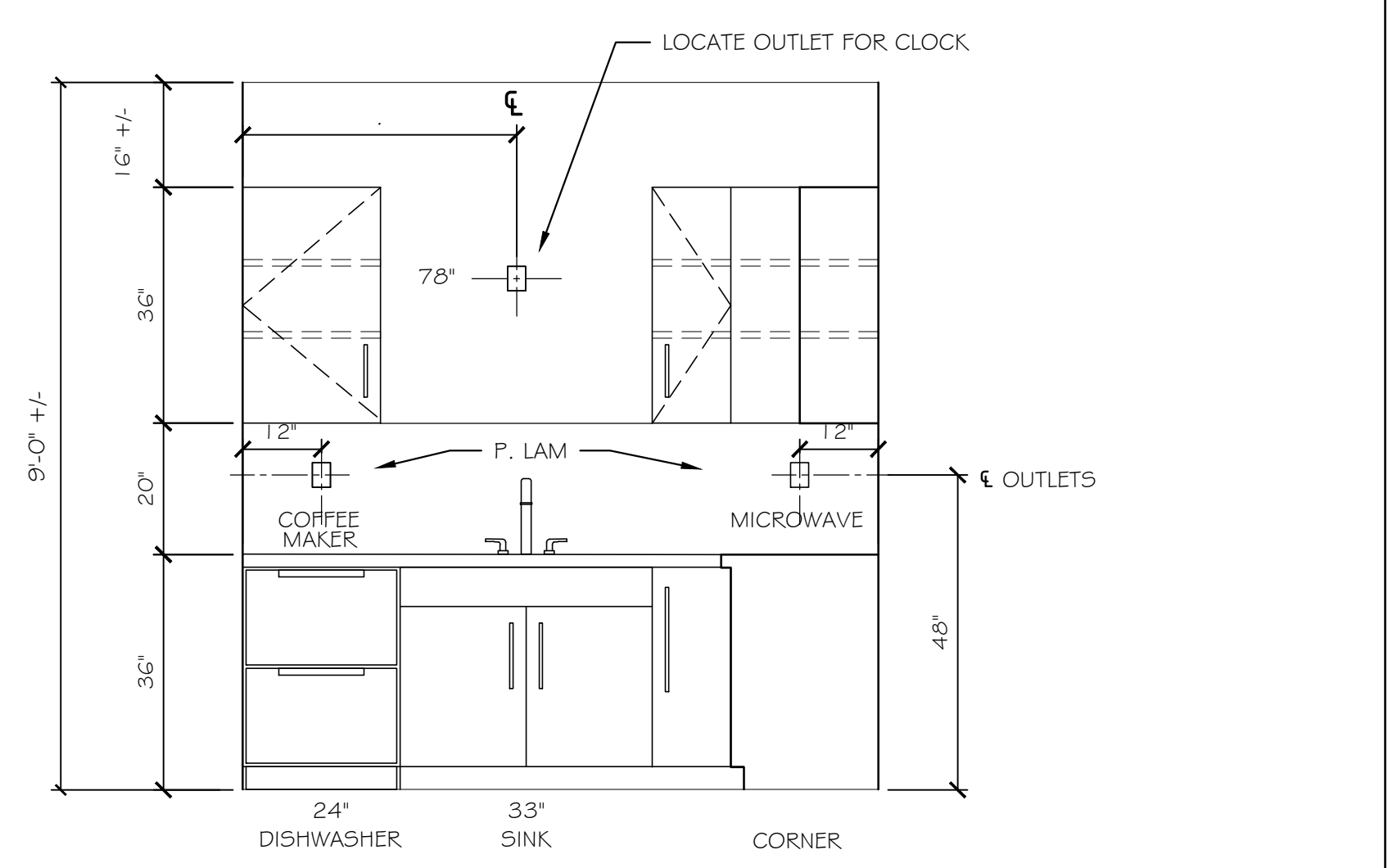

B ELEVATION B