

9 BAGGAGE HANDLING PLAN - PLATFORM - LEVEL 1 - ZONE 5  
B05.01.05 1/8" = 1'-0"

**SHEET NOTES**

**LEGEND**

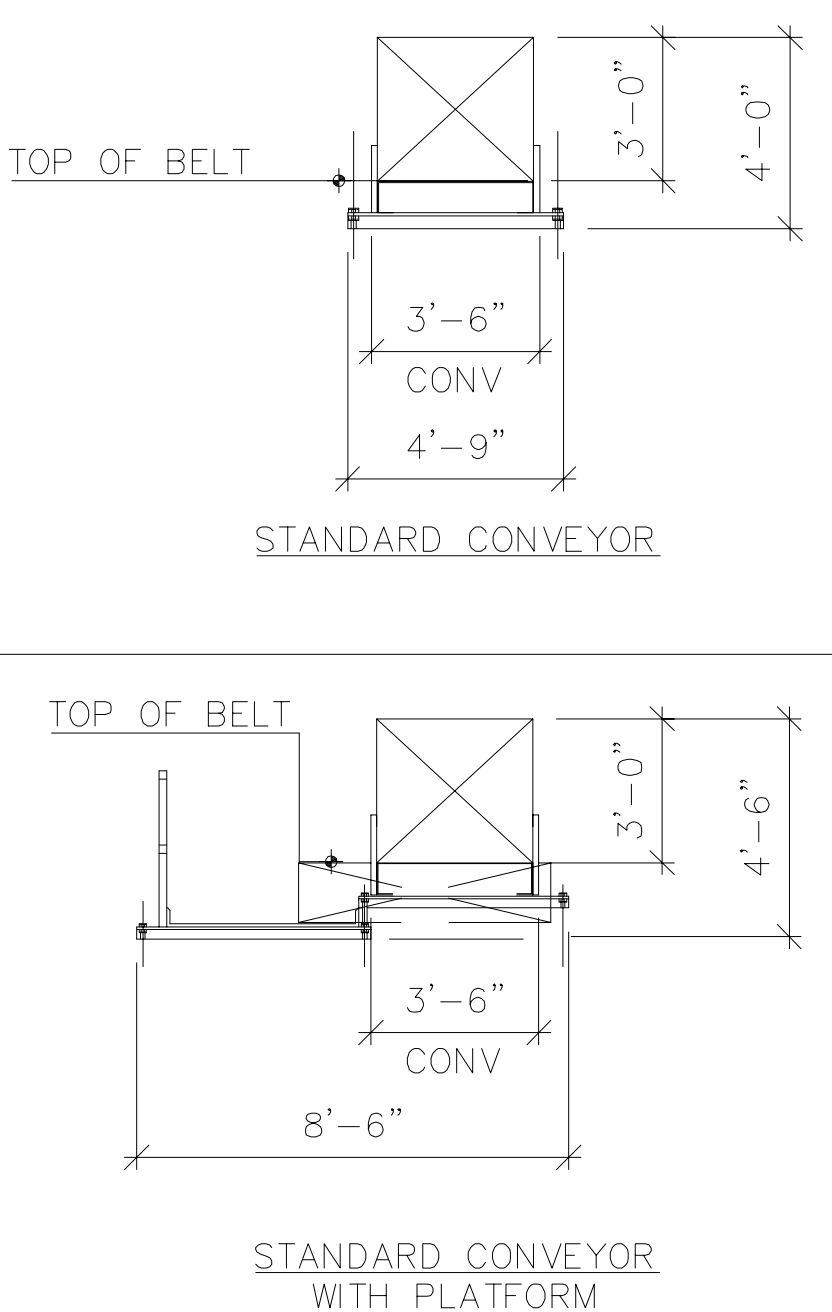

**GENERAL NOTES**

- THE FOLLOWING, TOGETHER WITH THE PROJECT SPECIFICATIONS AND BHS DRAWINGS SHALL APPLY:
- A. CHECK AND FIELD VERIFY ALL BHS RELATED DIMENSIONS ON THE JOB SITE BEFORE PROCEEDING WITH WORK, AND BE RESPONSIBLE FOR THEIR ACCURACY. IF DISCREPANCIES ARE FOUND BETWEEN THE BHS DRAWINGS, SPECIFICATIONS AND FIELD CONDITIONS, THEY SHALL BE REPORTED TO THE OWNER'S REPRESENTATIVE.
  - B. NO DIMENSIONS SHALL BE SCALED, DRAWINGS DIMENSIONS SHOWN SHALL BE USED.
  - C. REFERENCE STRUCTURAL DRAWINGS FOR BEAM LOCATIONS.
  - D. FOR ADDITIONAL BHS RIGHT-OF-WAY DETAILS SEE B12 SERIES.
  - E. ALL TICKET COUNTERS AND BAG WELLS SCALES NOT BY BHS CONTRACTOR.
  - F. BHS CONTRACTOR TO COORDINATE WITH ALL OTHER TRADES TO MAINTAIN BAGGAGE SYSTEM RIGHT-OF-WAY.
  - G. ALL DIMENSIONS ARE FROM COLUMN CENTER LINE TO FACE OF CONVEYOR SIDE GUARD, UNLESS OTHERWISE NOTED.
  - H. ALL OTHER TRADES TO MAINTAIN 3'-0" CLEAR RIGHT-OF-WAY FROM TOP OF BELT TO NEAREST OBSTRUCTION. HANGING OF ANY EQUIPMENT COMPONENTS MECHANICAL, ELECTRICAL, PLUMBING, HVAC... FROM THE CONVEYOR, CATWALK OR ASSOCIATED SUPPORTS IS NOT ALLOWED.
  - I. ALL BHS RIGHT-OF-WAY SHALL TAKE PRECEDENCE OVER ALL OTHER BUILDING SERVICES (MECHANICAL DUCT WORK AND PIPES, ELECTRICAL CONDUIT, SECURITY CONDUIT, FIRE PROTECTION PIPING, PLUMBING PIPES, ETC.)
  - J. ALL FINISHED FLOOR DIMENSIONS ARE TAKEN FROM THE HIGH POINT OF THE FINISHED FLOOR.

**KEY PLAN**

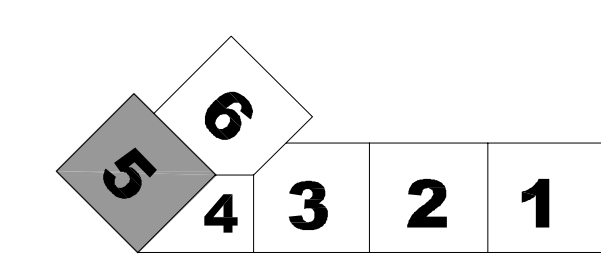

Portland International  
Jetport  
1001 Westbrook Street  
Portland, Maine 04102

**Gensler**

2020 K Street, NW  
Suite 200  
Washington, DC 20006  
Telephone 202.721.5200  
Facsimile 202.872.8587

**BNP ASSOCIATES, INC.**  
101 EAST RIDGE OFFICE PARK  
SUITE 103  
DANBURY, CT 06810 USA

PHONE: 203.792.3000  
FAX: 203.792.4900  
BNPHQ@BNPASSOCIATES.COM

Issue	Date & Issue Description	By	Check
01	7/15/09	BNP	JW/KS
02	9/15/09	BNP	JW/KS
03	10/26/09	BNP	JW/KS

Project Name  
PJM Terminal Expansion

Project Number  
09.6395.000  
CAD File Name  
B05.01.05.dwg

Description  
BAGGAGE HANDLING PLAN - PLATFORM - LEVEL 1 - ZONE 5

Scale

Ref. North

**B05.01.05**

©2009 Gensler