

**TRESPA/GYP DETAIL**  
SCALE: 6" = 1'-0"  
A09.33 **21**

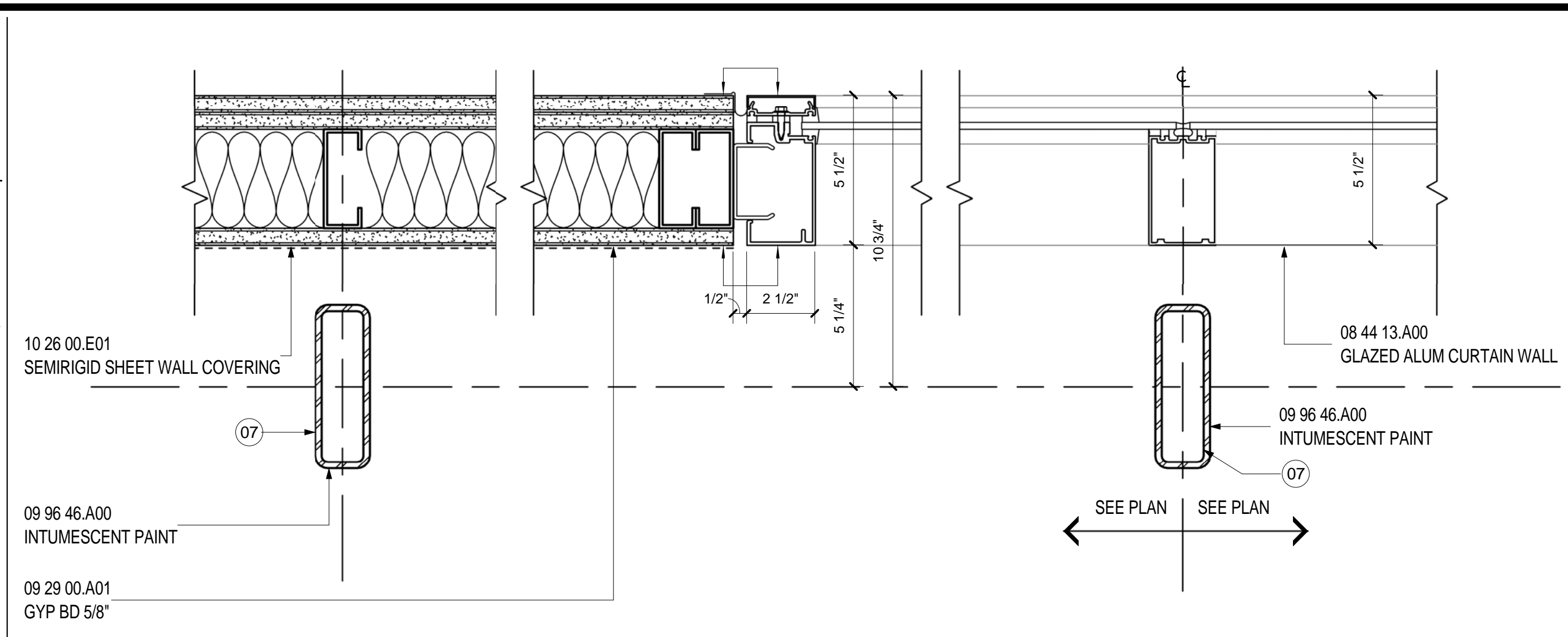

**JAMB-INT.CUR.WALL- CORRIDOR**  
SCALE: 3" = 1'-0"  
A02.03.02 **9**

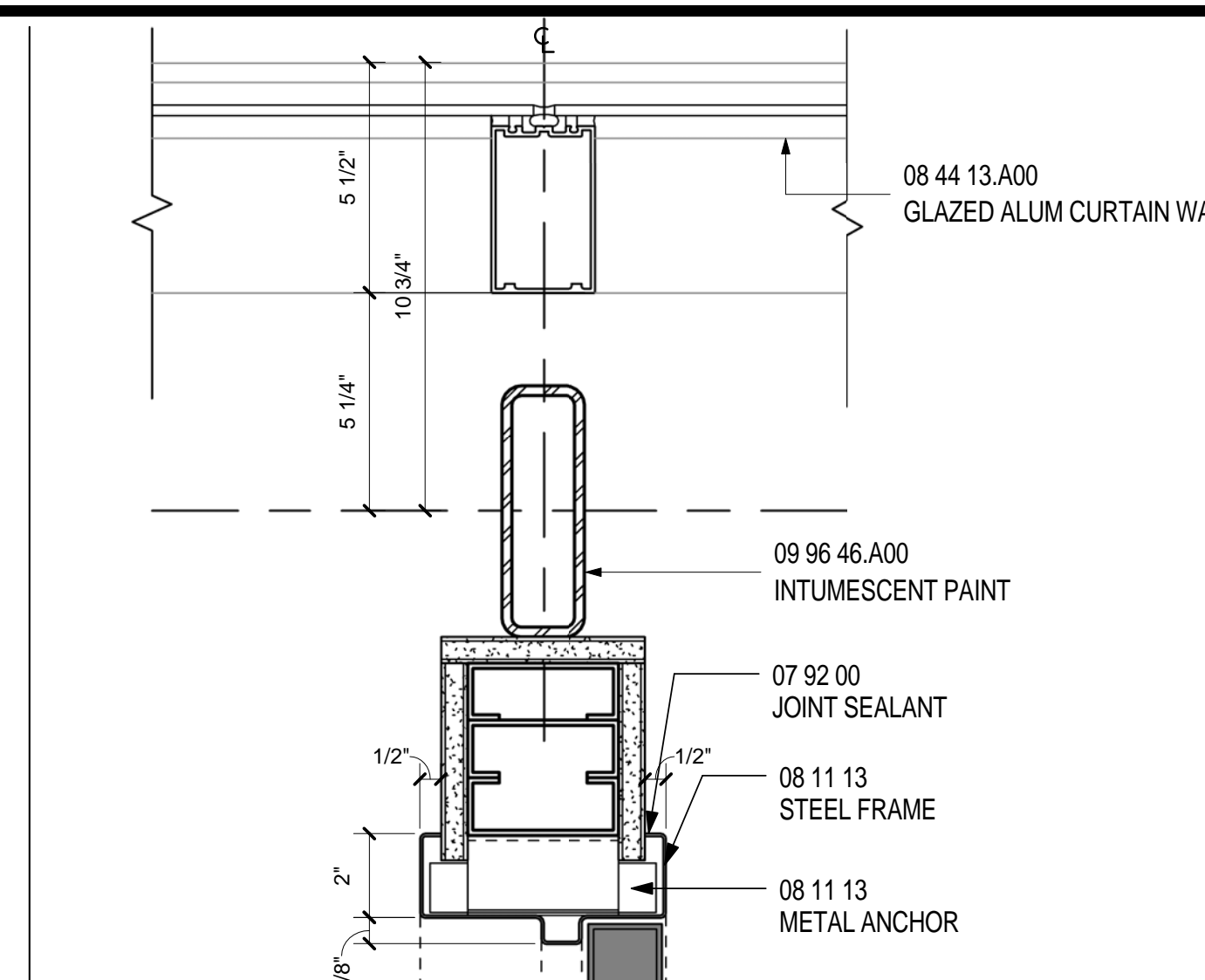

**MULLION-INT.CUR.WALL- CORRIDOR**  
SCALE: 3" = 1'-0"  
A02.03.02 **4**

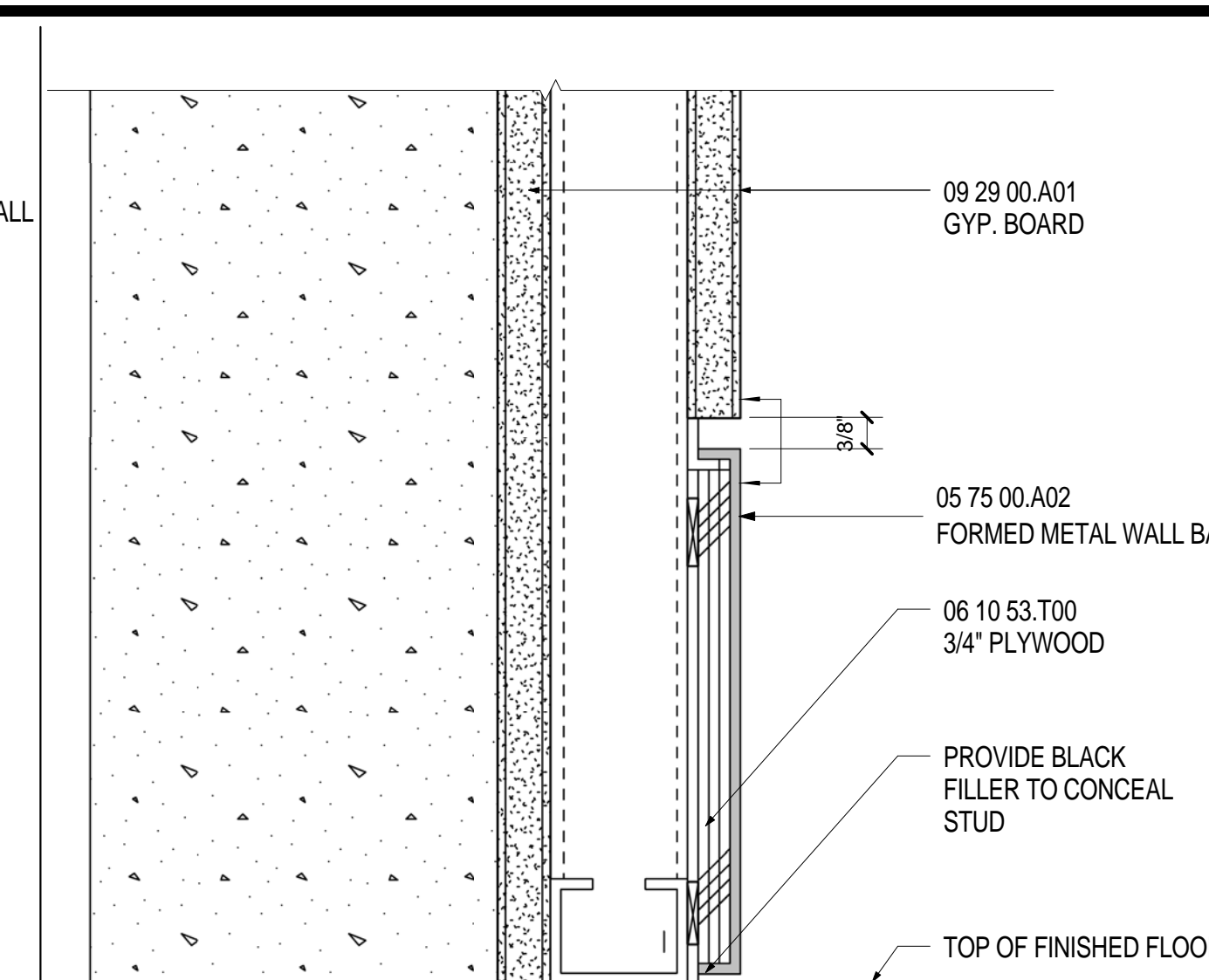

**GYP EDGE - FLUSHED METAL BASE**  
SCALE: 6" = 1'-0"  
A11.20 **1**

**SHEET NOTES**

- BUTT JOINT BETWEEN PANEL AND JAMB
- PROVIDE STAINLESS STEEL FLATSTOCK REVEAL, TYP AT DOOR TYPE B
- SCHEDULED CEILING, RE: A04 SERIES FOR REFLECTED CEILING PLANS
- ALIGN WITH CENTER LINE OF EXTERIOR CURTAINWALL MULLION
- SCHEDULED DOOR, RE: A00.30 FOR DOOR SCHEDULE
- SCHEDULED PARTITION, RE: A02 SERIES FOR CONSTRUCTION PLAN AND PARTITION TYPES. VERIFY THICKNESS.
- STRUCTURAL STEEL, RE: STRUCTURAL DRAWINGS FOR ADDITIONAL INFORMATION
- SCHEDULED ADJACENT PARTITION WHERE OCCURS, RE: CONSTRUCTION PLAN
- METAL REVEAL
- CONCRETE SLAB, RE: STRUCTURAL DRAWINGS
- LINE OF SILL BELOW
- LINE OF JAMB BEYOND
- SCHEDULED FINISH FLOOR, RE: A05 SERIES FOR FINISH PLANS
- REVEAL AND FILLER TO BE PAINTED BLACK
- PROVIDE KICKERS AS REQUIRED TO STRUCTURE ABOVE. COORDINATE LOCATIONS WITH MEP.

**Portland International Jetport**  
1001 Westbrook Street  
Portland, Maine 04102

2020 K Street, Northwest  
Suite 200  
Washington, DC 20006  
Telephone 202.721.5200  
Facsimile 202.872.8587

**Gensler**

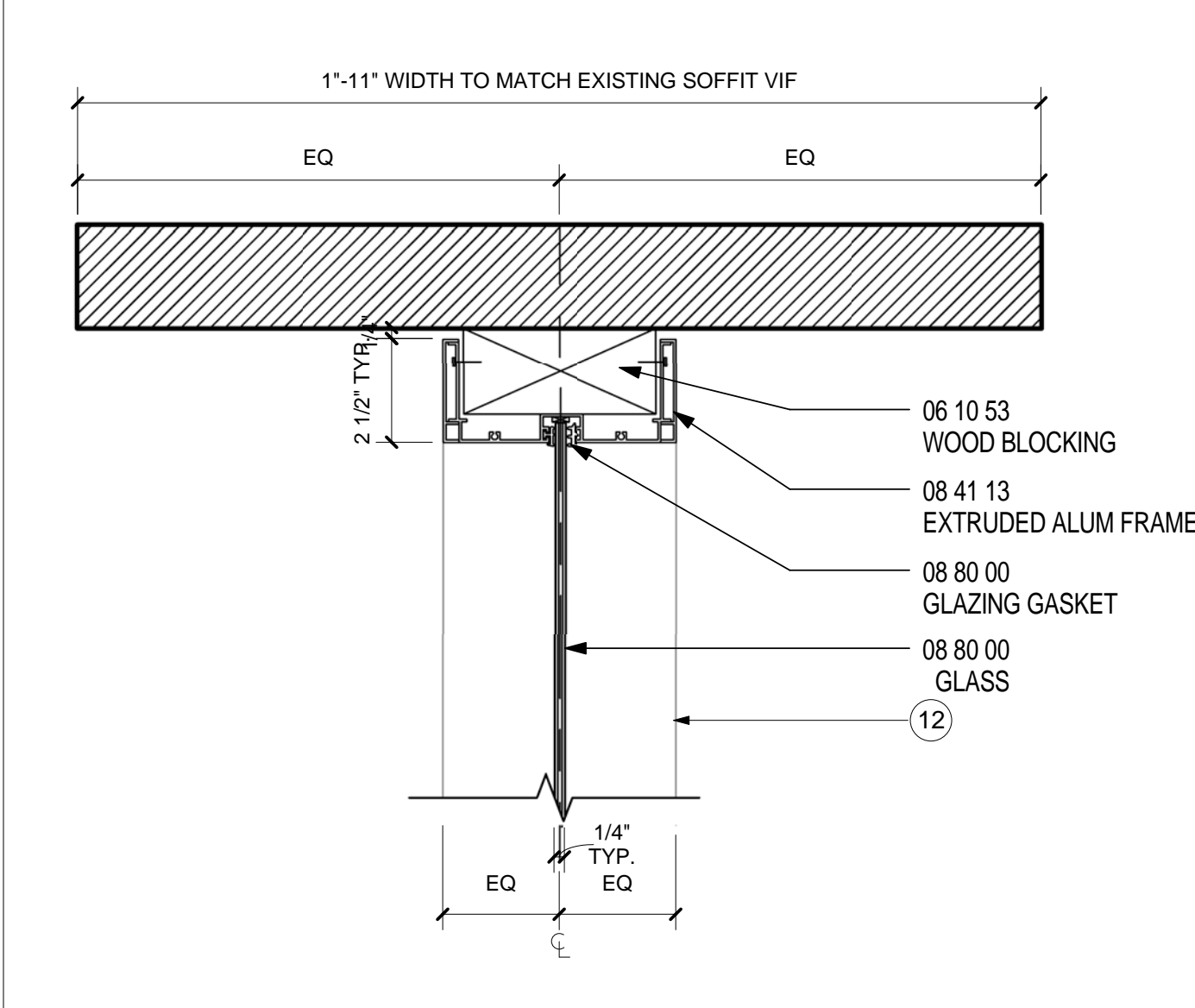

**HEAD 3- DOOR TYPE C- STOREFRONT**  
SCALE: 3" = 1'-0"  
A11.12 **17**

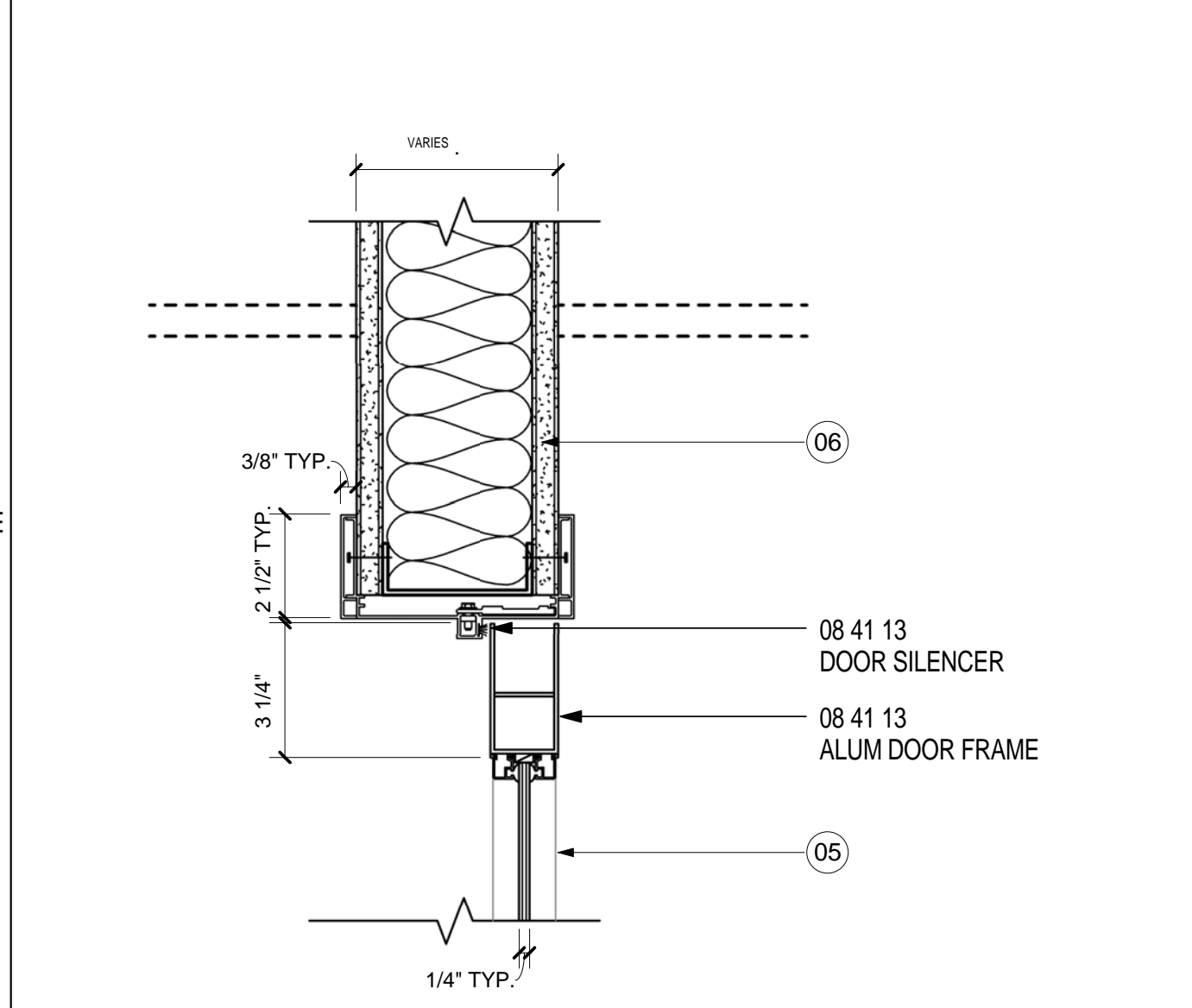

**HEAD 1- DOOR TYPE C- STOREFRONT**  
SCALE: 3" = 1'-0"  
**13**

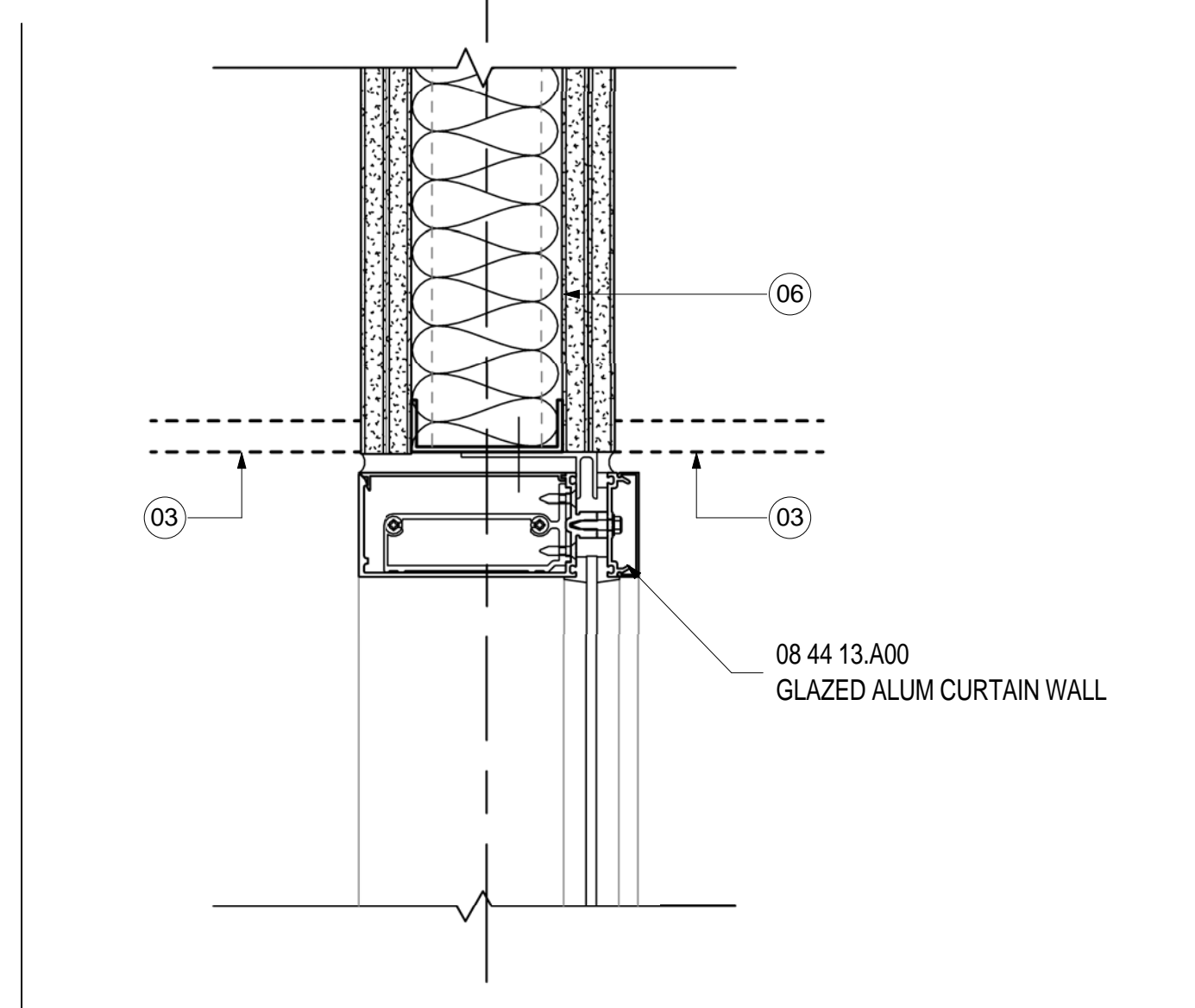

**HEAD-INT.CUR.WALL-SSCP/TICKETING**  
SCALE: 3" = 1'-0"  
A11.02 **10**

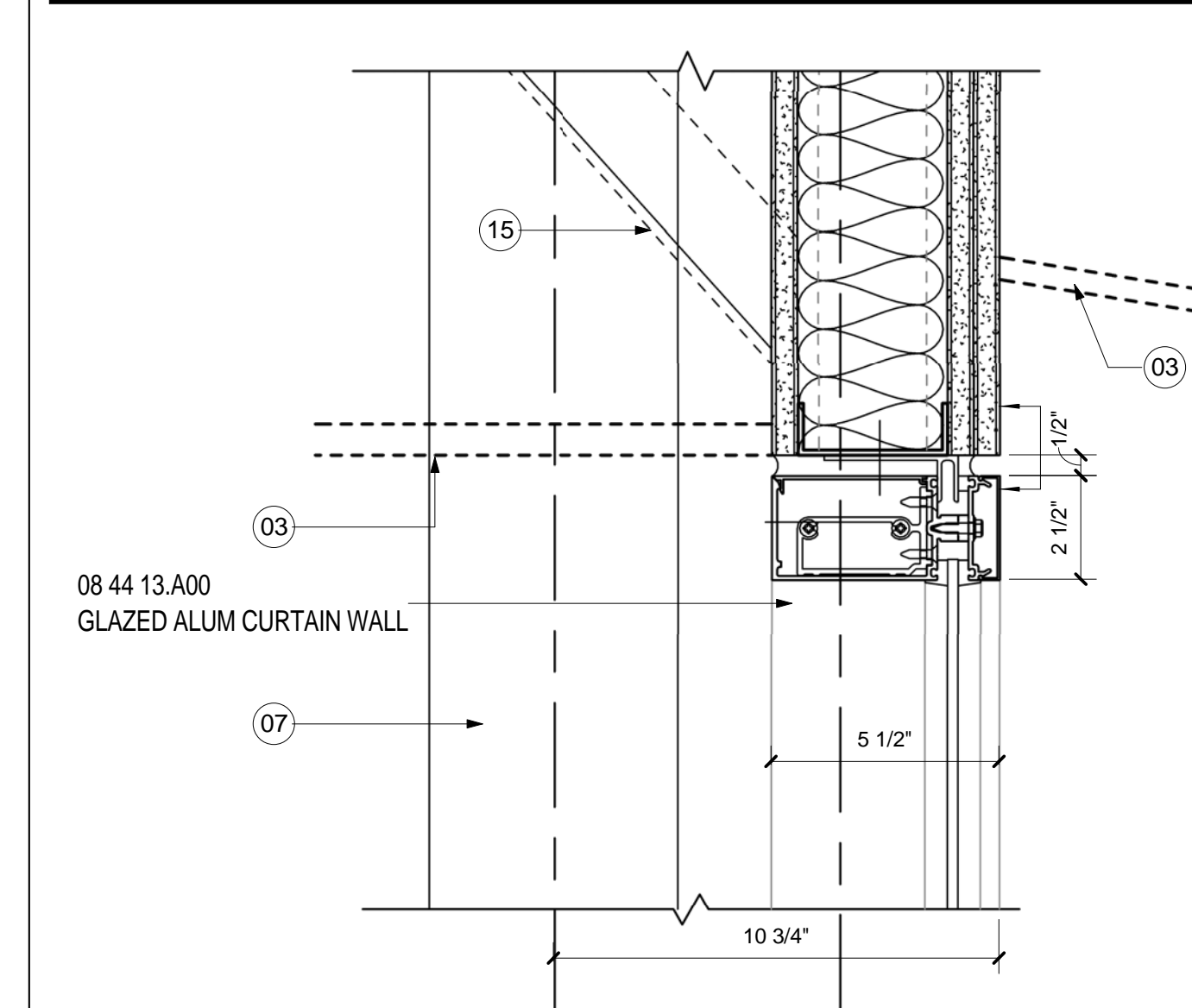

**HEAD-INT.CUR.WALL- CORRIDOR**  
SCALE: 3" = 1'-0"  
A04.03.02 **5**

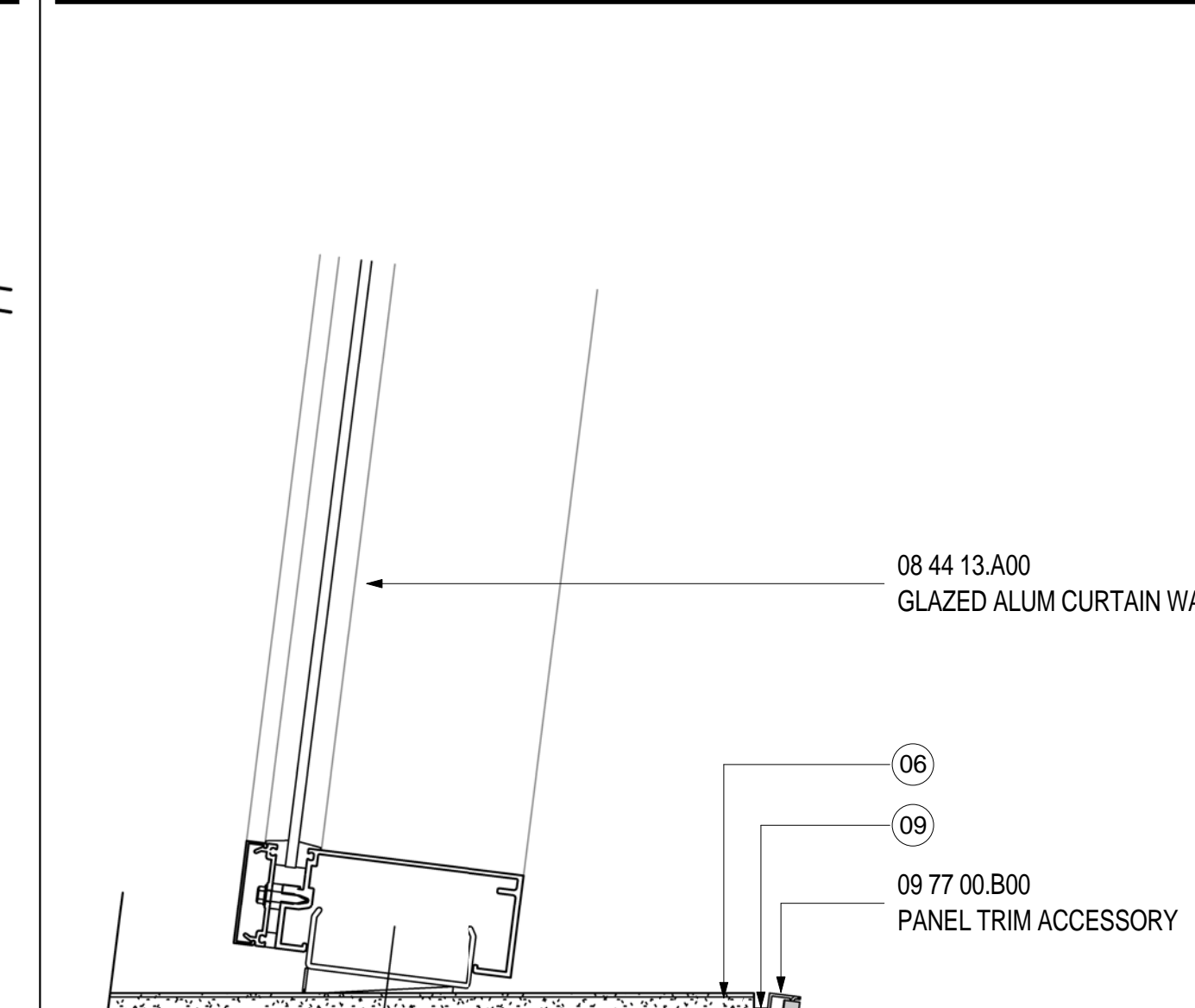

**JAMB-INT.CUR.WALL AT LEO ROOM**  
SCALE: 3" = 1'-0"  
A02.04.04 **2**

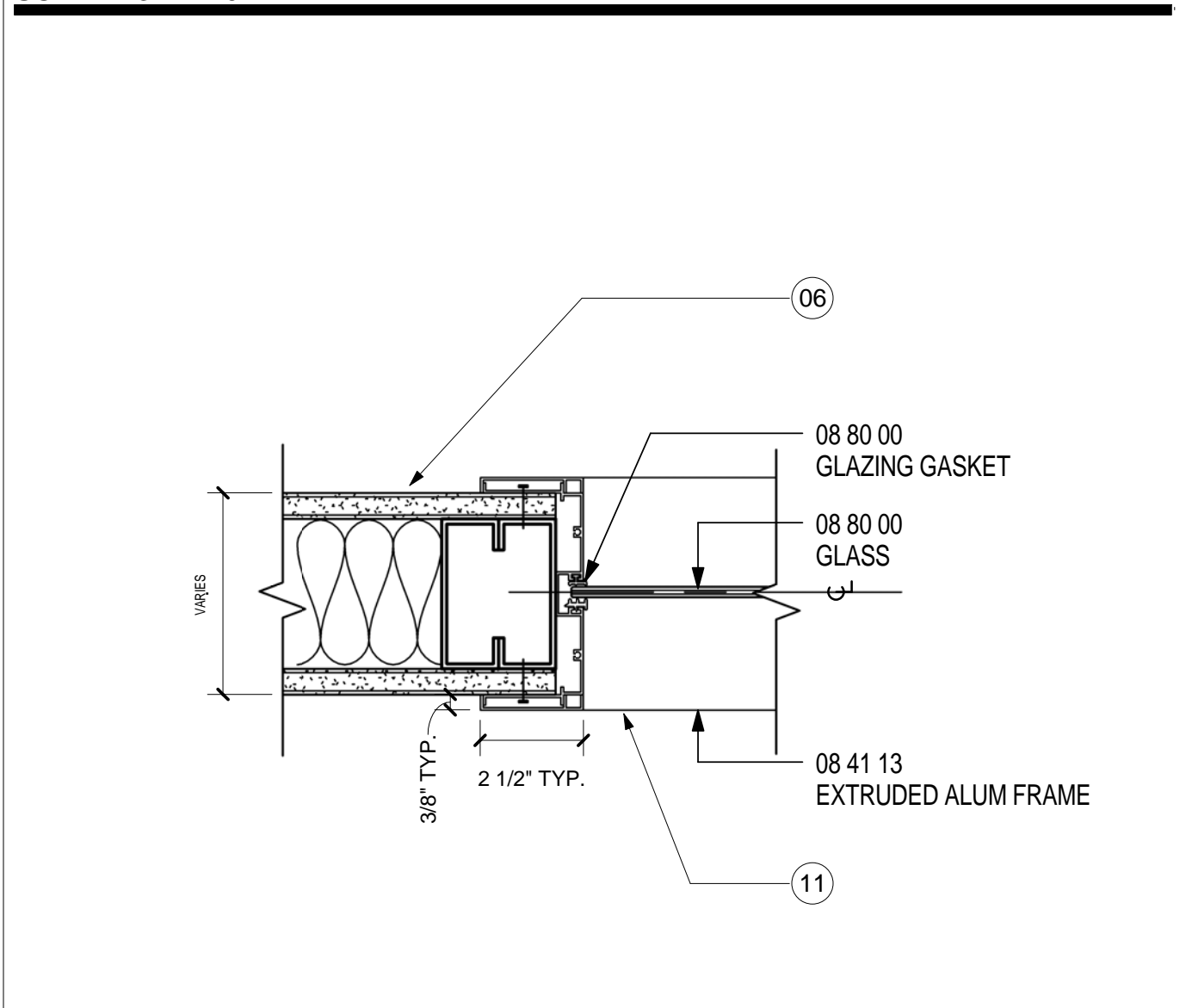

**JAMB 3- DOOR TYPE C- STOREFRONT**  
SCALE: 3" = 1'-0"  
**18**

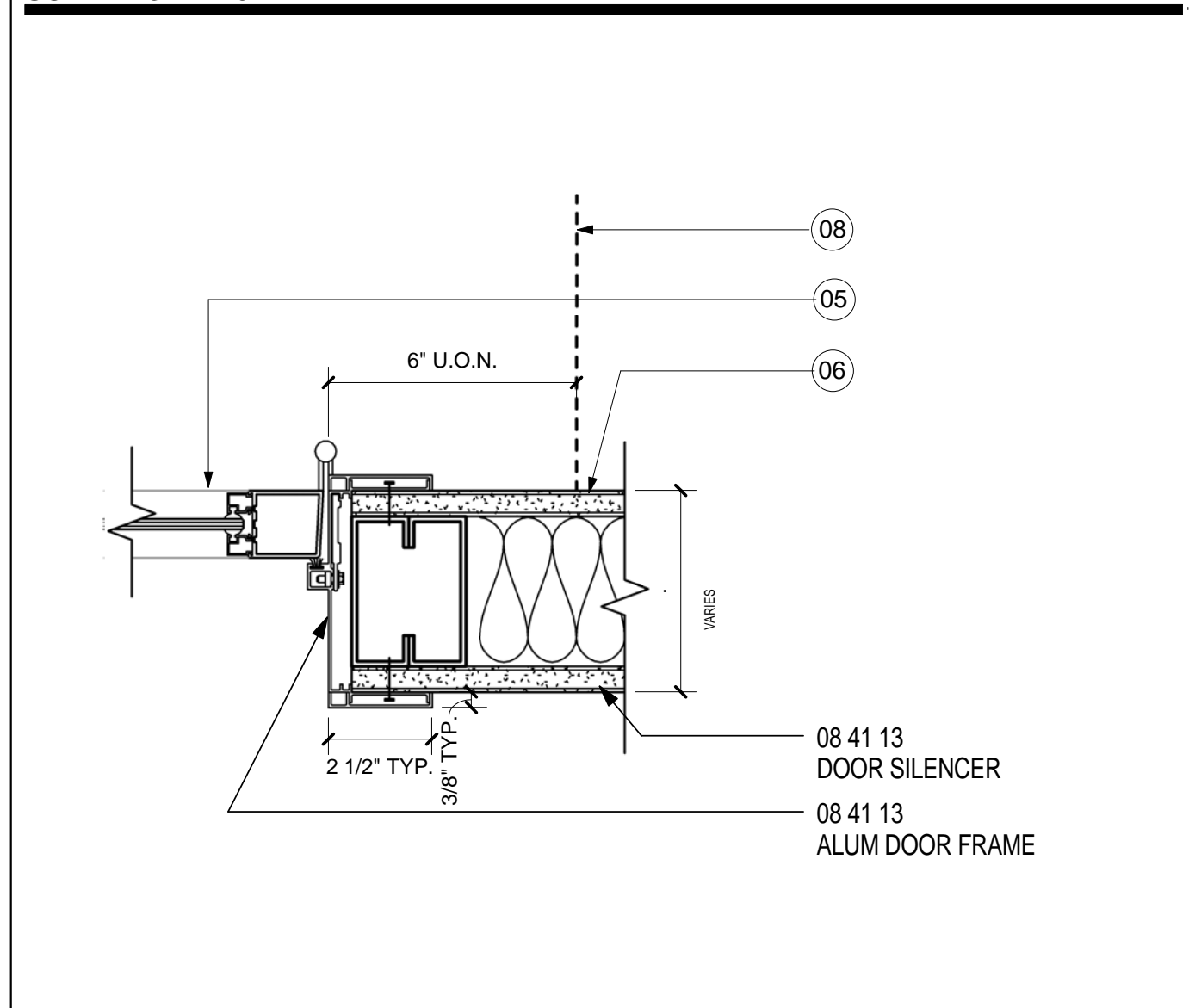

**JAMB 1 - DOOR TYPE C- STOREFRONT**  
SCALE: 3" = 1'-0"  
**14**

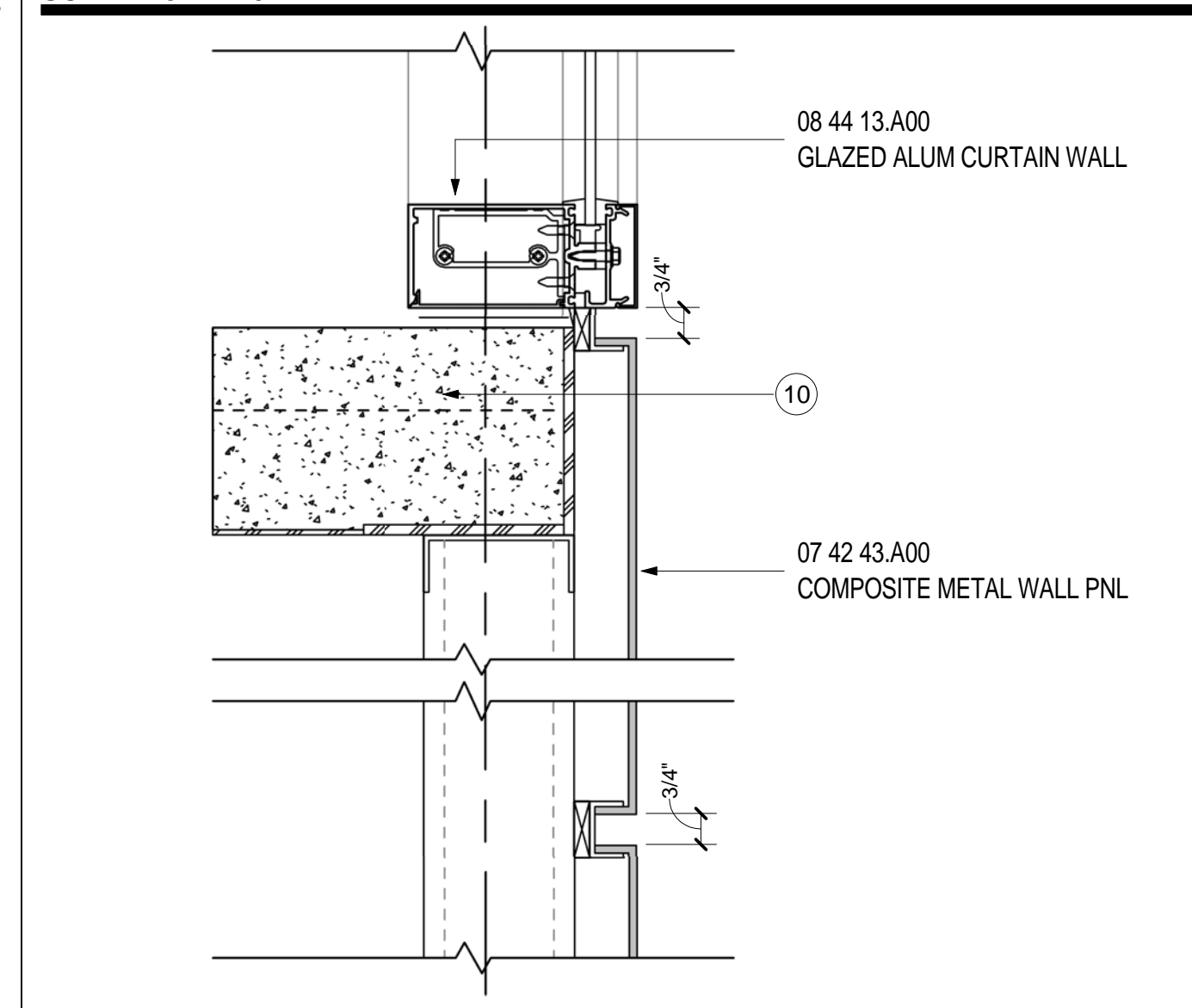

**SILL-INT.CUR.WALL- SSCP/TICKETING**  
SCALE: 3" = 1'-0"  
A11.02 **11**

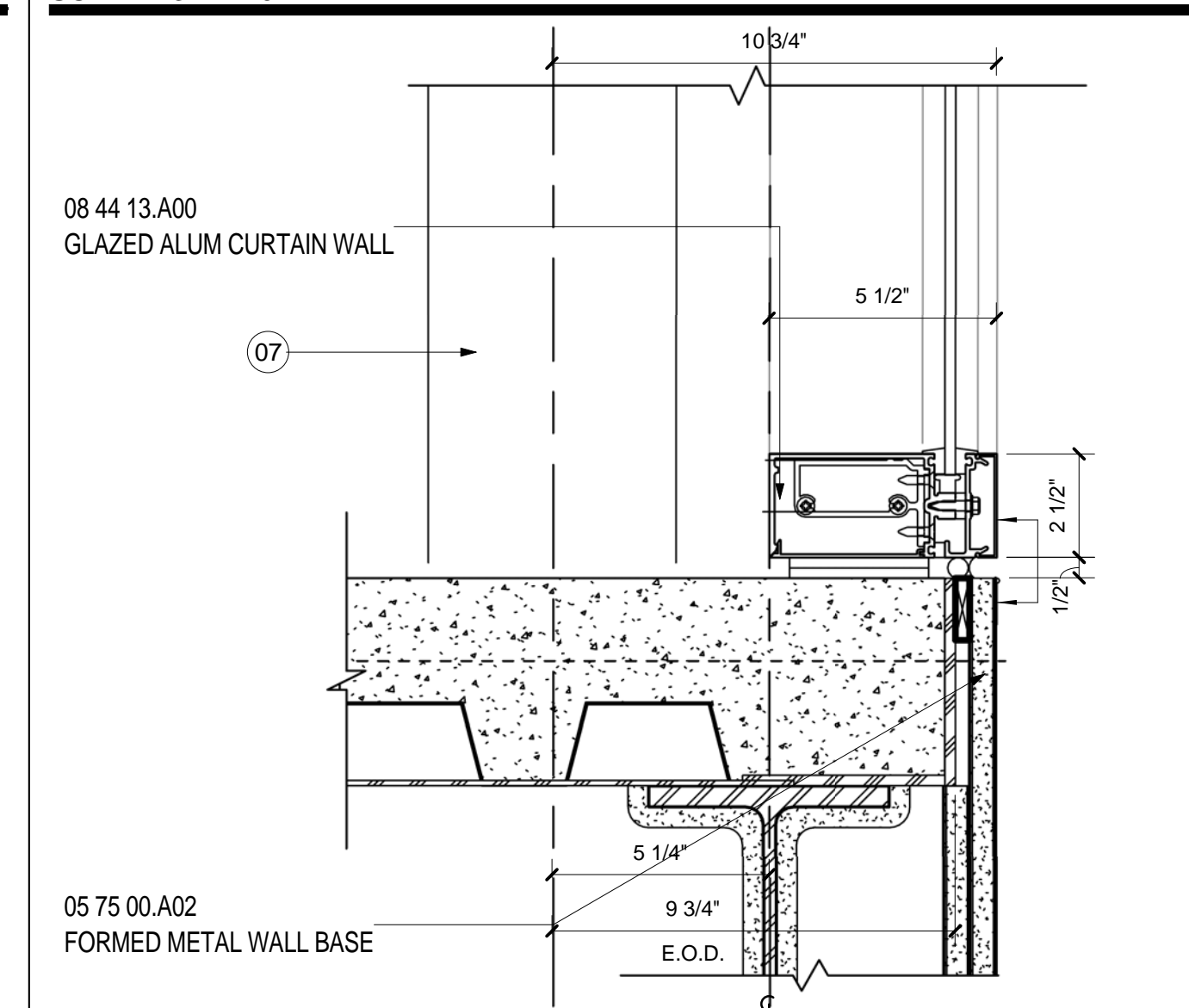

**SILL 1- INT.CUR.WALL- CORRIDOR**  
SCALE: 3" = 1'-0"  
A11.01 **6**

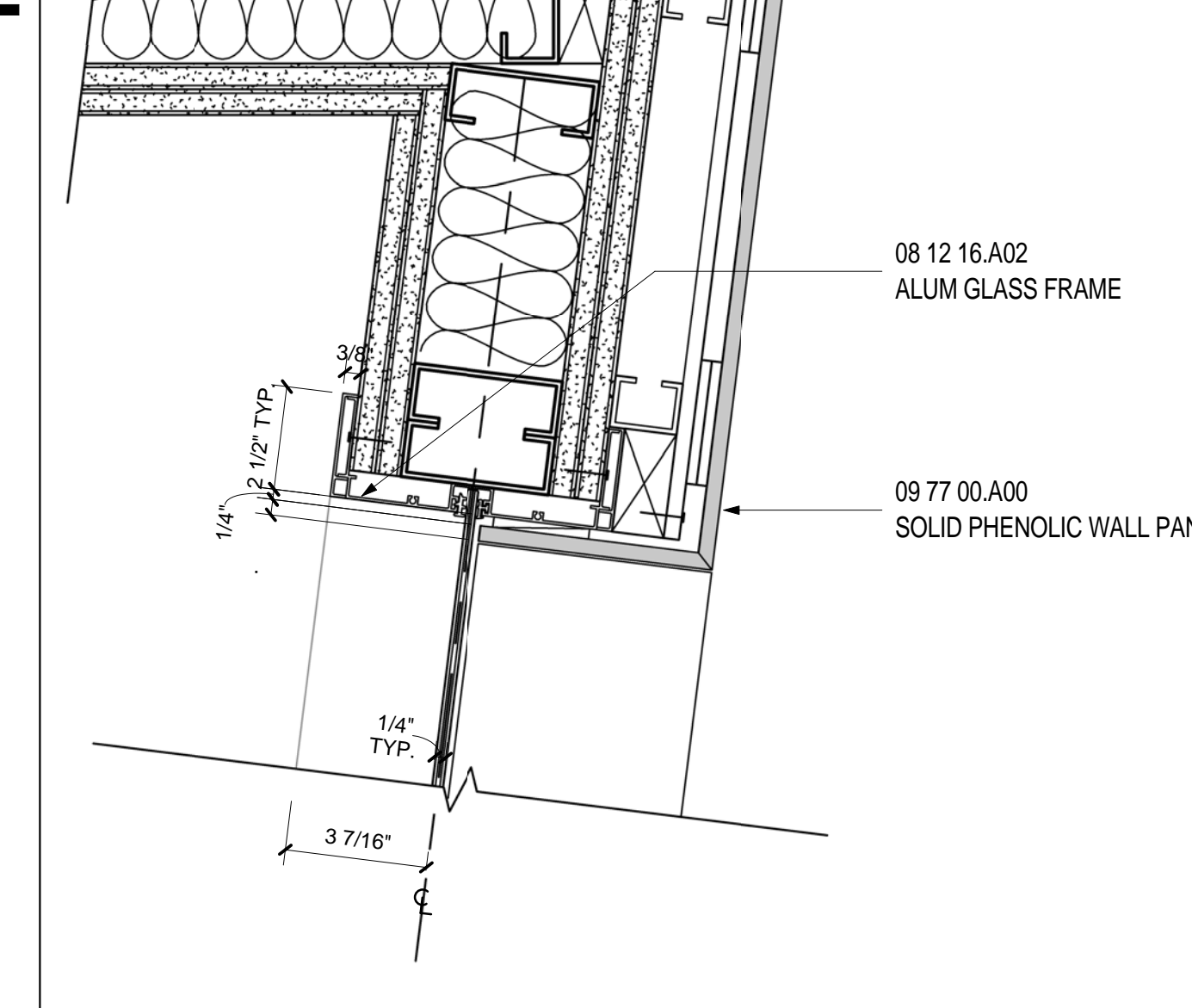

**JAMB-INT.CUR.WALL AT LEO ROOM**  
SCALE: 3" = 1'-0"  
A02.04.04 **2**

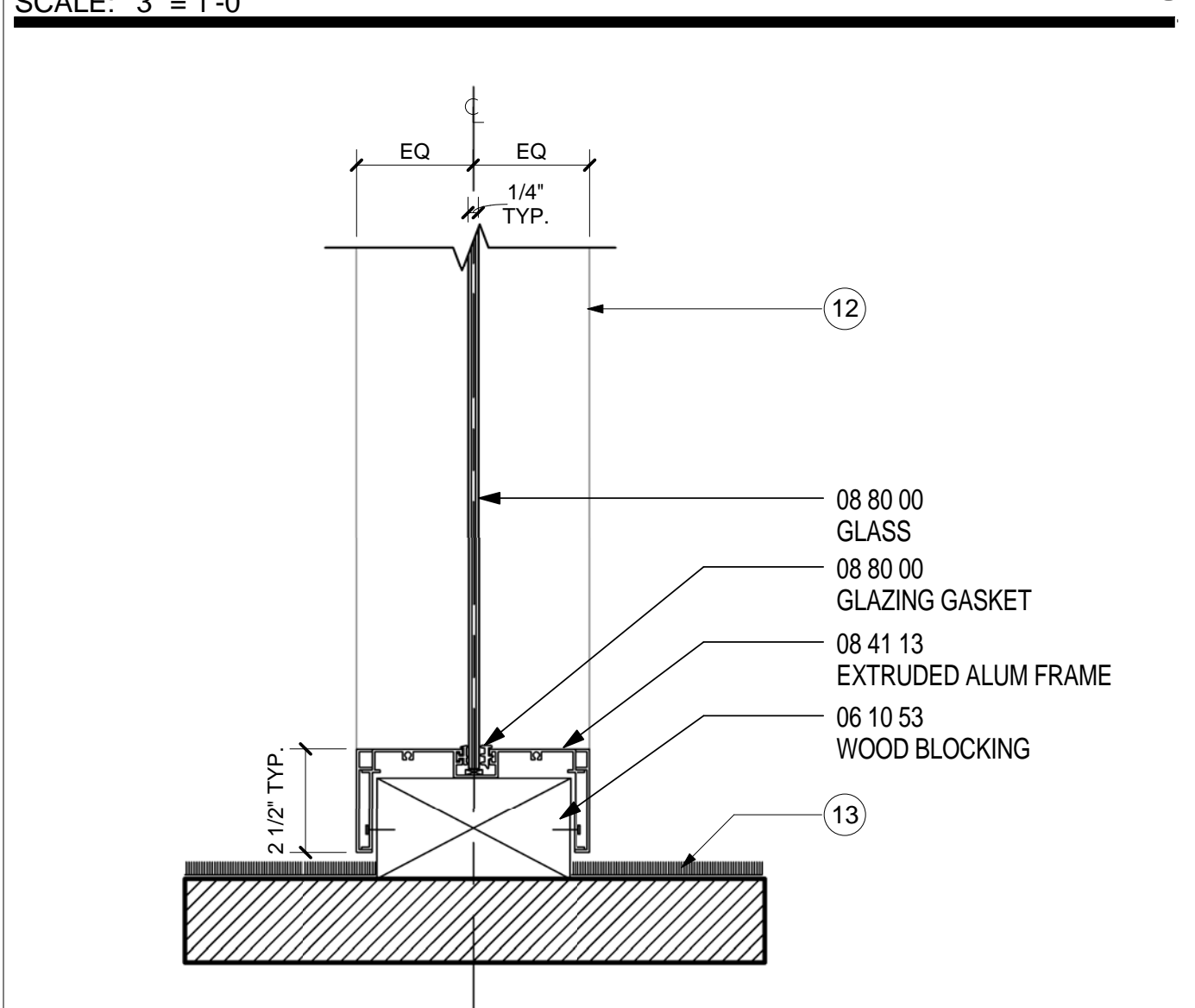

**SILL- DOOR TYPE C- STOREFRONT**  
SCALE: 3" = 1'-0"  
A11.12 **19**

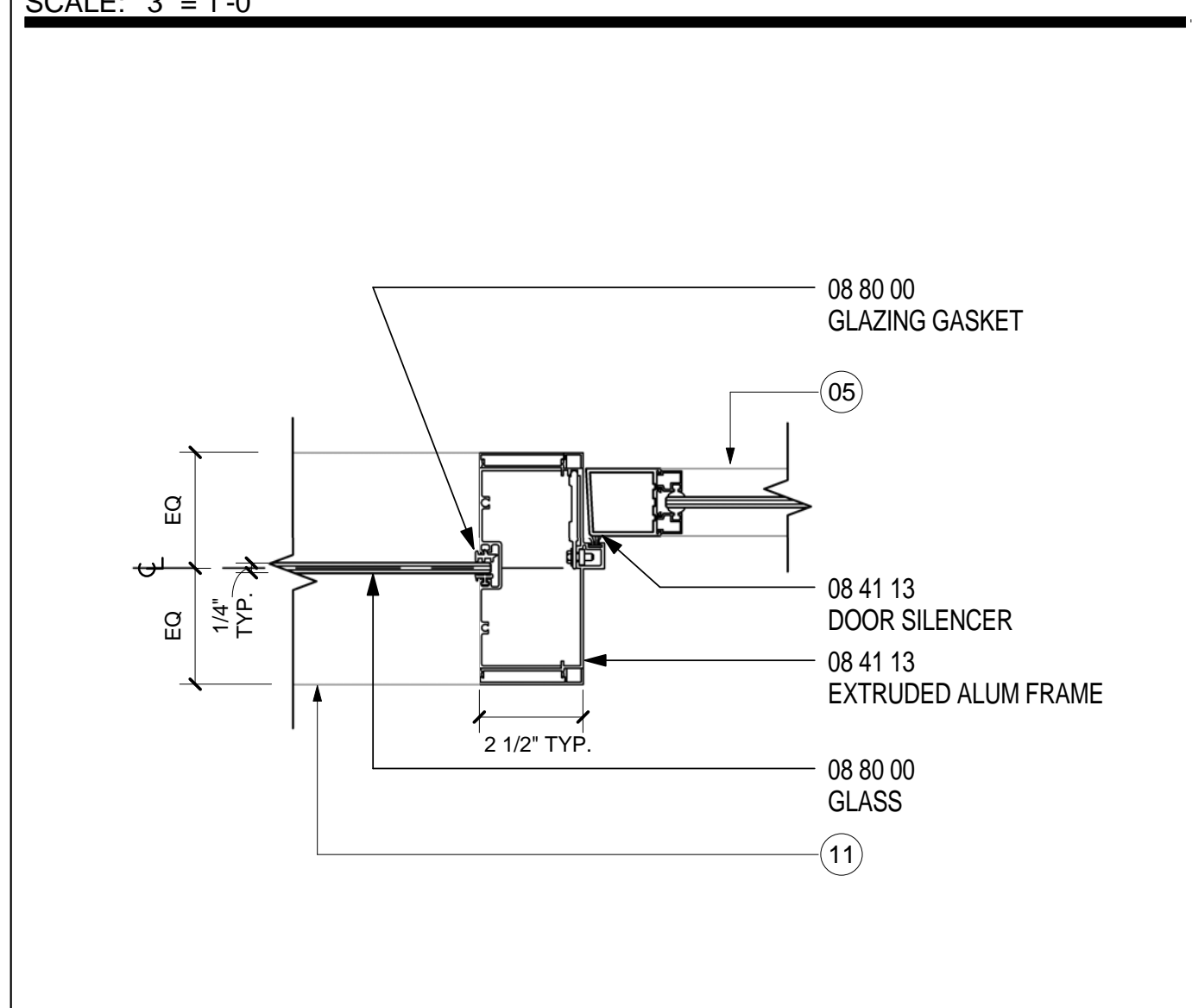

**JAMB 2- DOOR TYPE C- STOREFRONT**  
SCALE: 3" = 1'-0"  
**15**

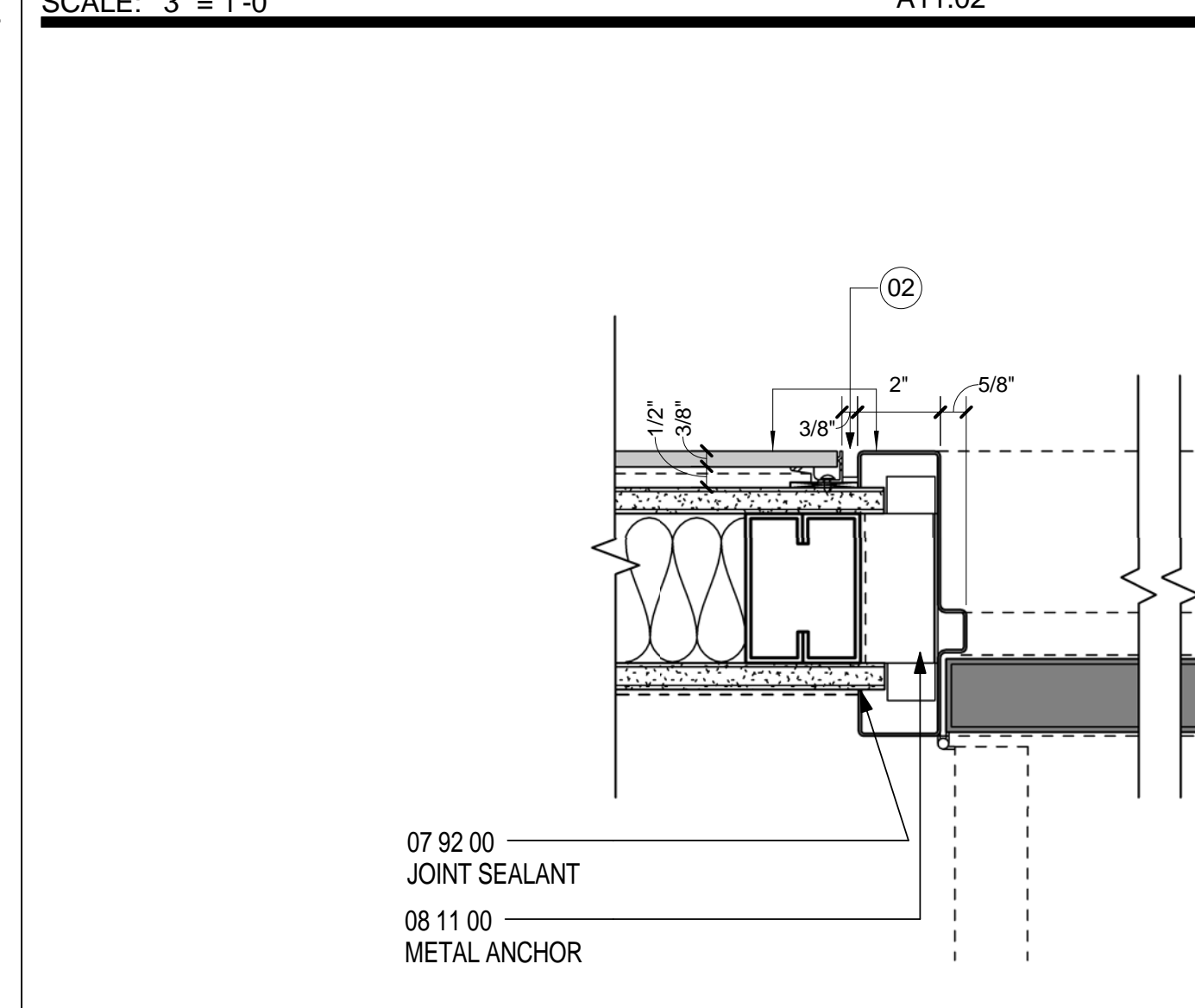

**JAMB- DOOR TYPE B**  
SCALE: 3" = 1'-0"  
A11.10 **7**

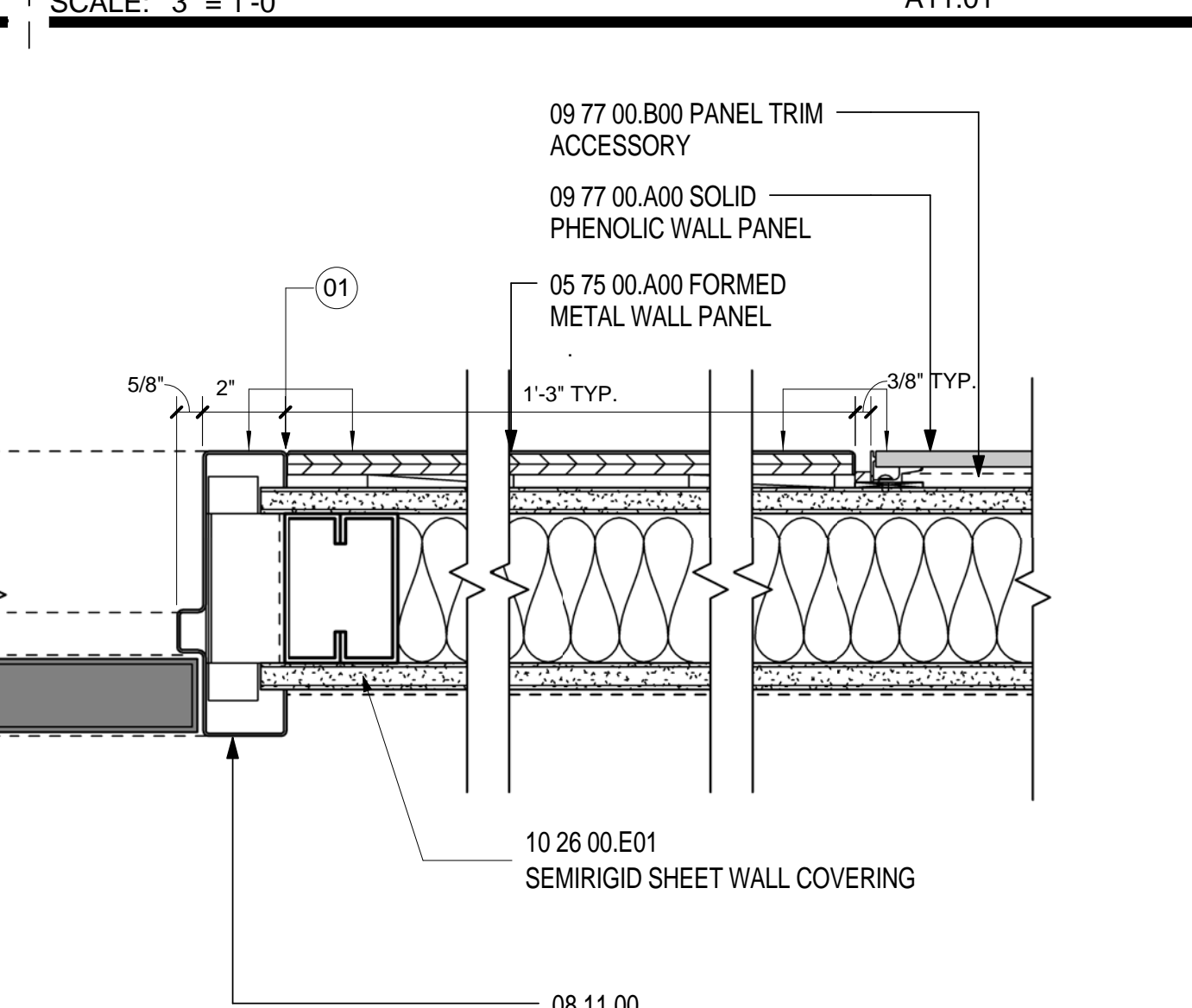

**CORNER DETAIL- STOREFRONT**  
SCALE: 3" = 1'-0"  
A11.12 **8**

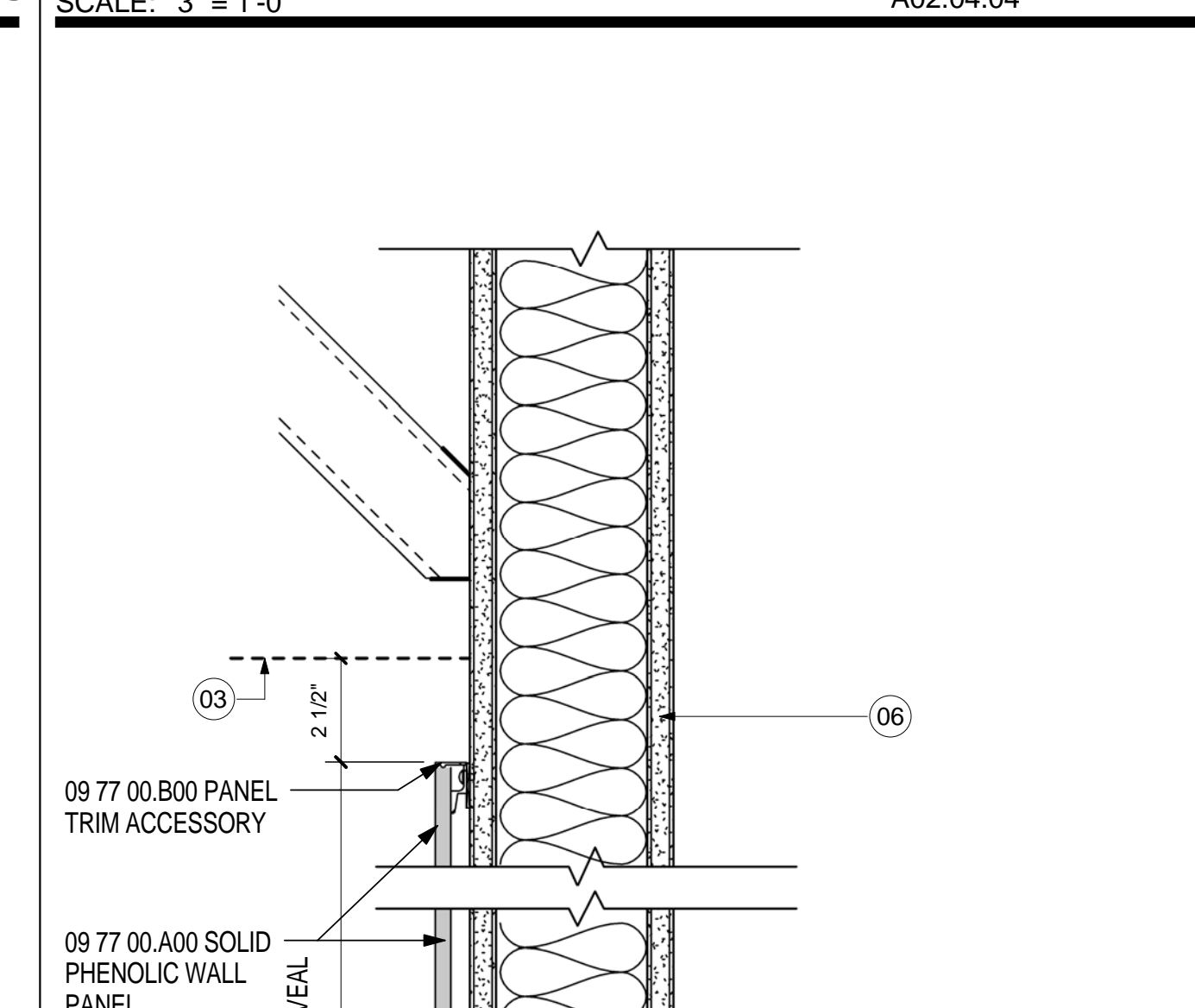

**HEAD- DOOR TYPE B**  
SCALE: 3" = 1'-0"  
**3**

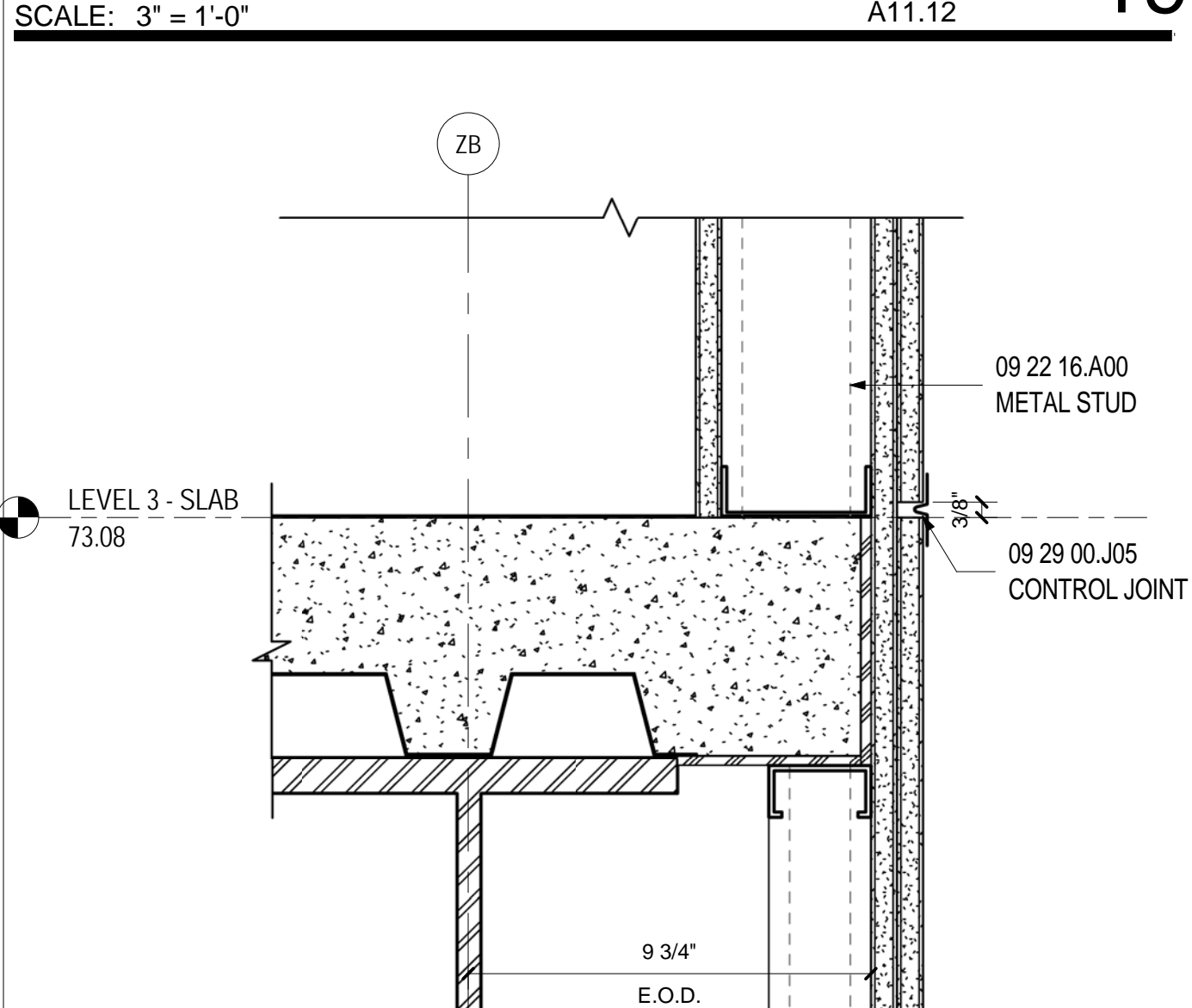

**WALL SECTION AT CORRIDOR 2504**  
SCALE: 3" = 1'-0"  
A02.03.04 **20**

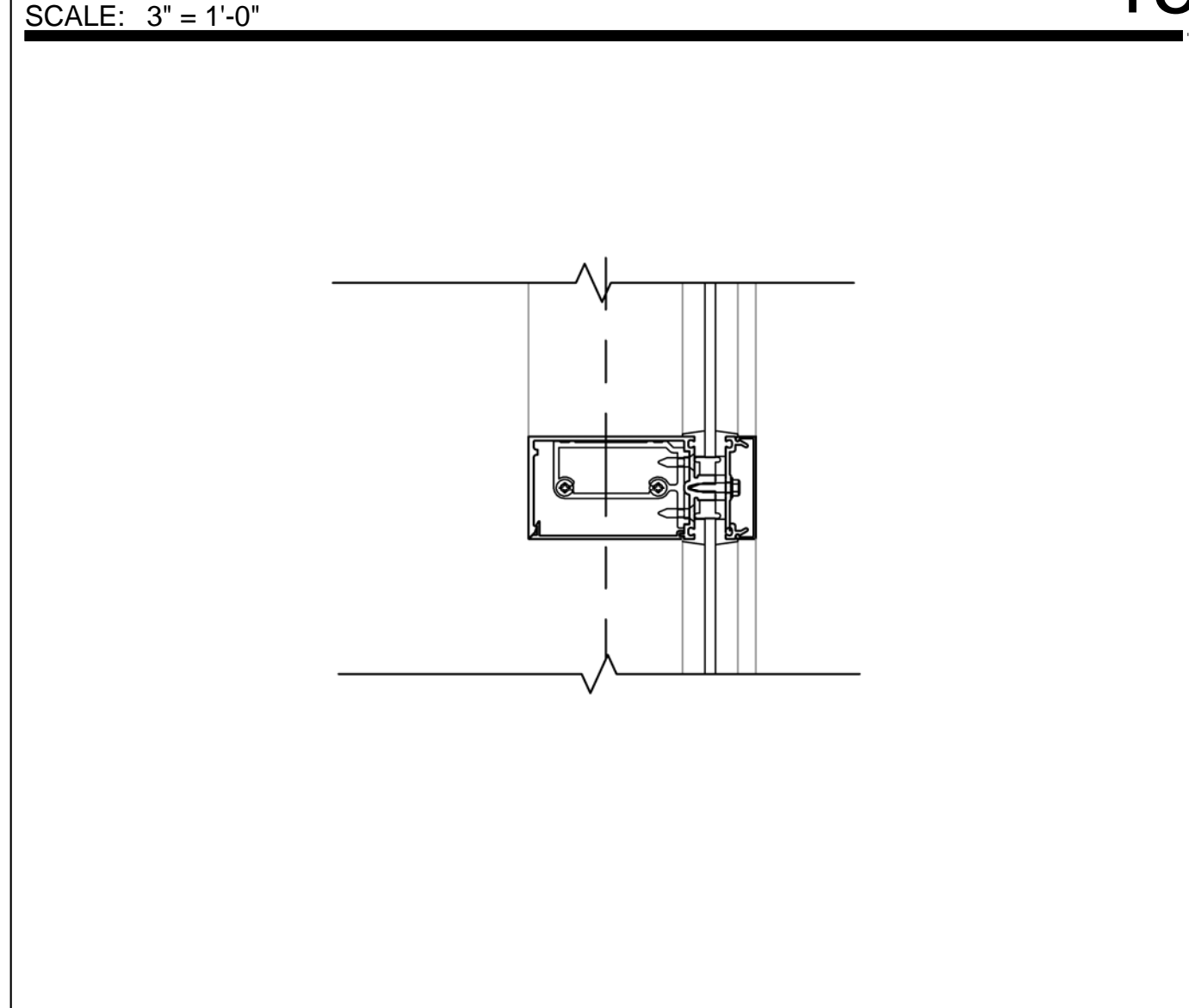

**INTERMED MULLION- SSCP/TICKETING**  
SCALE: 3" = 1'-0"  
A11.02 **16**

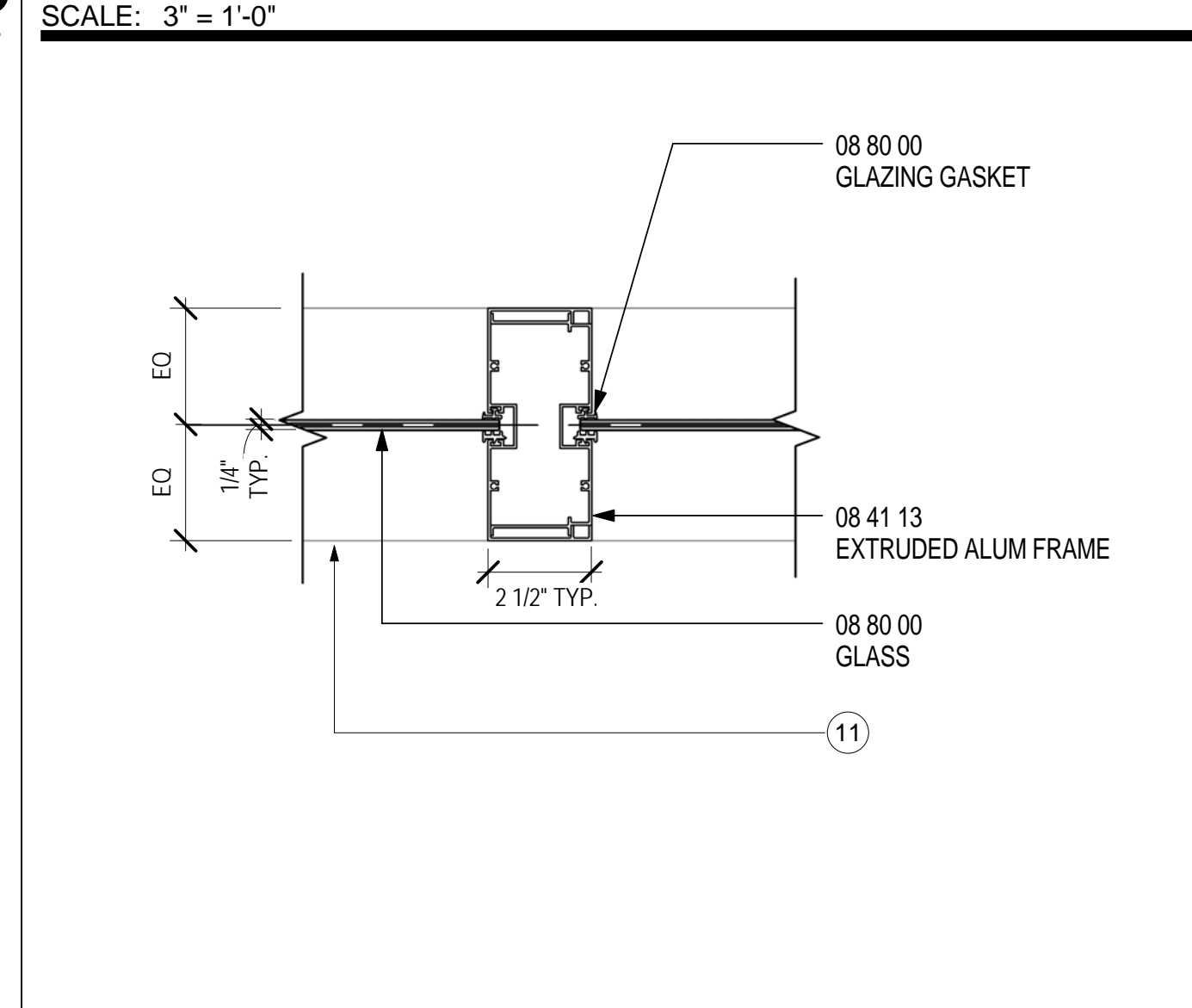

**MULLION- DOOR TYPE C- STOREFRONT**  
SCALE: 3" = 1'-0"  
A11.12 **12**

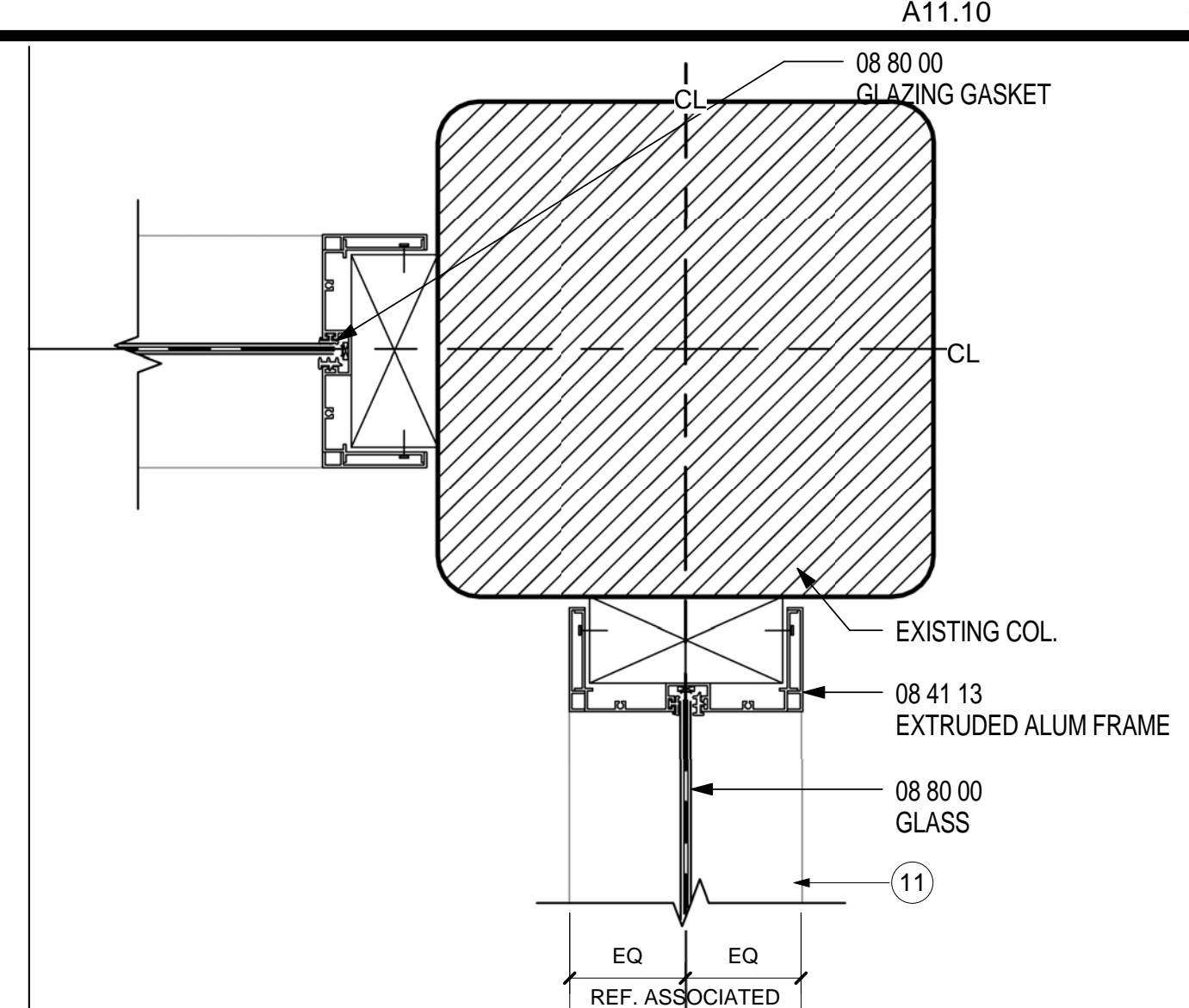

**CORNER DETAIL- STOREFRONT**  
SCALE: 3" = 1'-0"  
A11.12 **8**

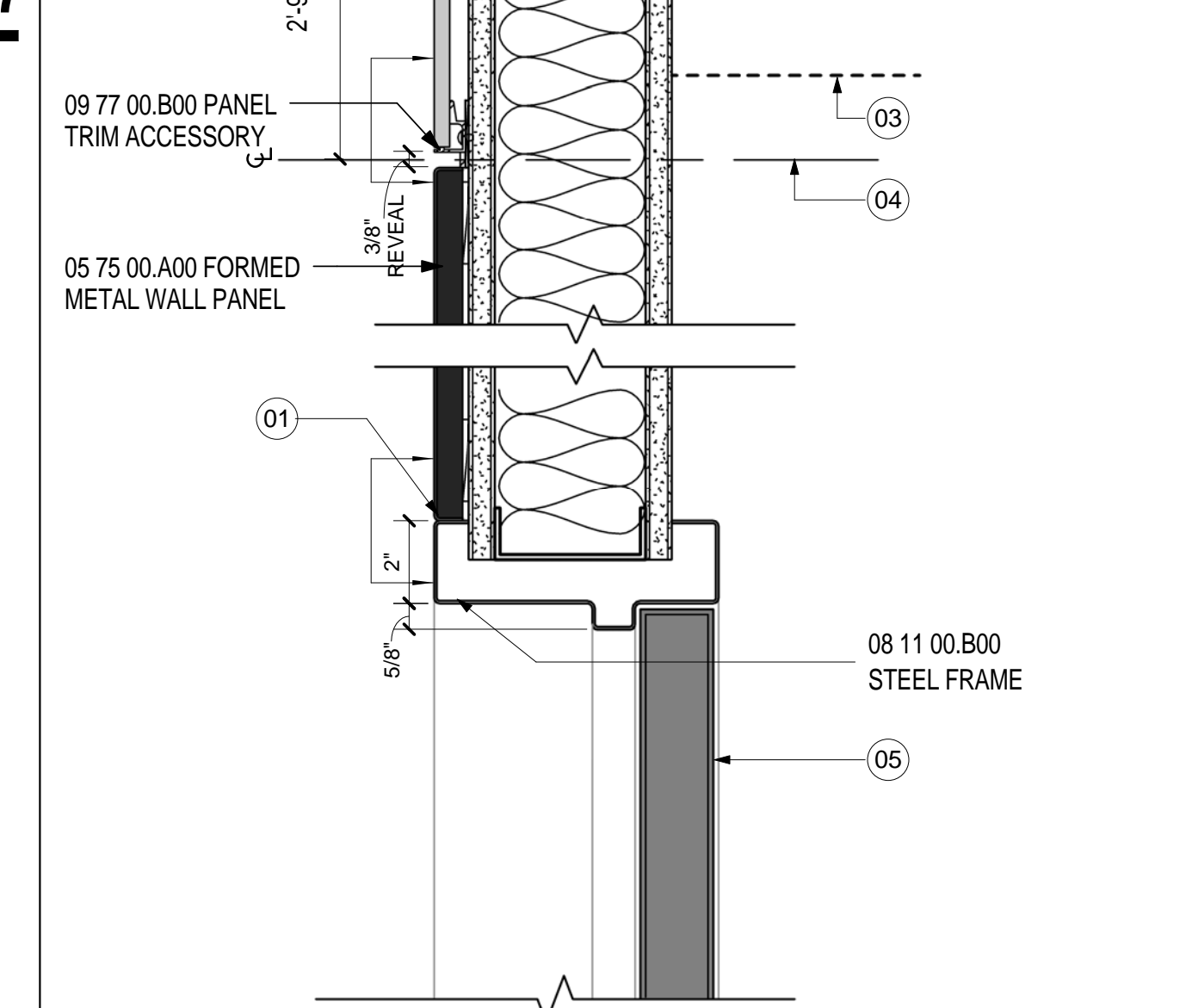

**HEAD- DOOR TYPE B**  
SCALE: 3" = 1'-0"  
**3**

**GENERAL NOTES**

Seal/Signature

Project Name  
PJM Terminal Enhancement

Project Number  
09.6395.000

Description  
INTERIOR DETAILS

Scale  
As indicated

**A12.65**

© 2009 Gensler

Date	Description
01/23/09	95% CONSTRUCTION DOCUMENTS
10/26/09	ISSUED FOR PERMIT
145 09/01/11	ISSUED FOR CONSTRUCTION

Seal/Signature

Project Name  
PJM Terminal Enhancement

Project Number  
09.6395.000

Description  
INTERIOR DETAILS

Scale  
As indicated

**A12.65**

© 2009 Gensler