

NOTES

1. REFER TO FLOOR PLAN FOR WALL TO BOXED HEADER REQUIREMENT.

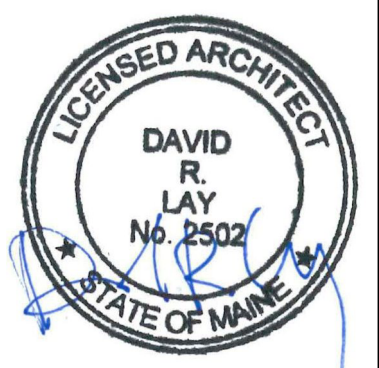

ARCHITECTURE 144 Fore Street, P.O. Box 618
 Portland, Maine 04104
 Tel: (207) 772-3846
 Fax: (207) 772-1070
 www.smartr.com

SMART
 ARCHITECTURE
 ENGINEERING
 PLANNING
 INTERIORS
 ENERGY

SMRT PROJECT NO. 17033

REV:	0	BY:		DATE:	12/21/17
ISSUED FOR CONSTRUCTION					
STATUS:					
THIS PLAN SHALL NOT BE MODIFIED WITHOUT WRITTEN PERMISSION FROM SEBAGO TECHNICS, INC. ALL CHANGES SHALL BE AT THE USER'S SOLE RISK AND WITHOUT LIABILITY TO SEBAGO TECHNICS, INC.					

PROJECT NO.	17033
FIELD BOOK	
DESIGN	
CHKD	
DRAWN	

WWW.SEBAGOTECHNICS.COM
 75 John Roberts Rd., Suite 1A
 South Portland, ME 04086
 Tel: (207) 772-3846
 Fax: (207) 772-1070

MOUNTING HEIGHTS, WALL AND ROOF TYPES,
 TOP OF WALL DETAILS
 OF:
 PORTLAND INTERNATIONAL JETPORT
 GATE UPGRADES
 1001 WESTBROOK STREET
 PORTLAND, MAINE 04102

DATE	SCALE
12/21/17	As indicated

1.G1002

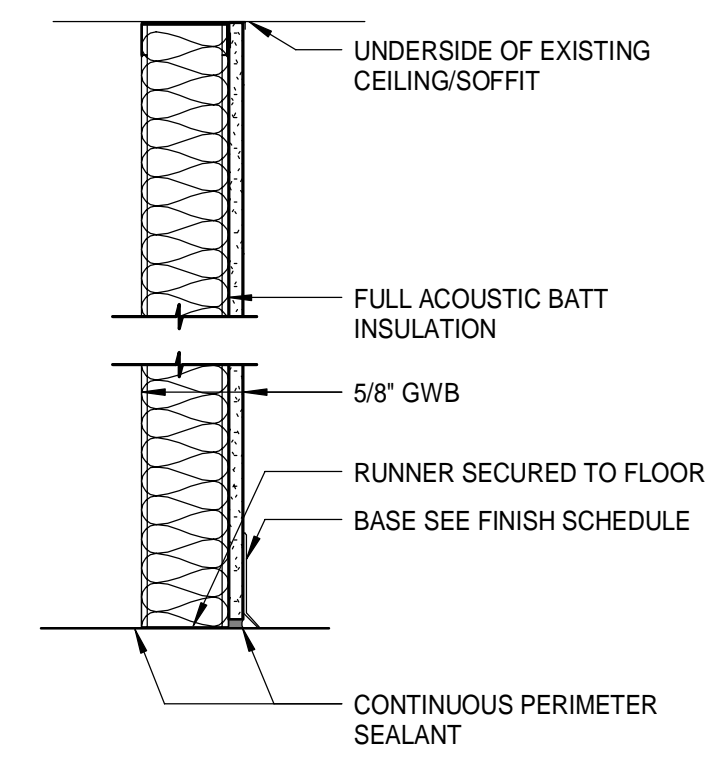

TYPE F3.a NON-RATED

(STC 45) ONE LAYER 5/8" GWB TAGGED SIDE OF 3 5/8" METAL STUDS.

TYPE F6.a NON-RATED

(STC 45) ONE LAYER 5/8" GWB TAGGED SIDE OF 6" METAL STUDS.

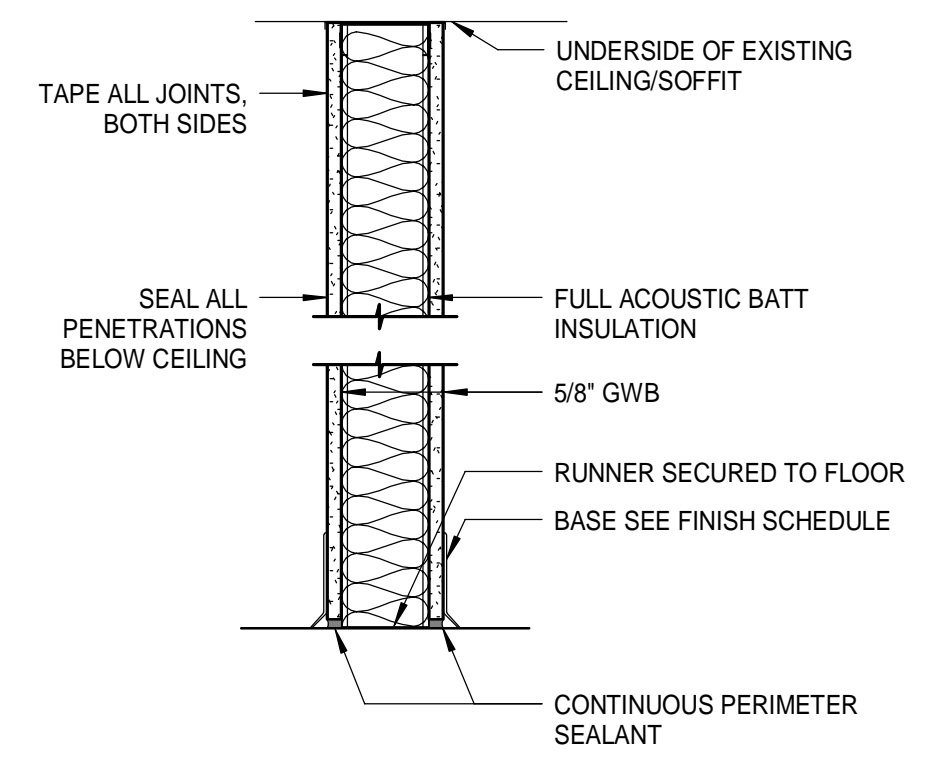

TYPE S3.a NON-RATED

(STC 45) ONE LAYER 5/8" GWB EACH SIDE OF 3 5/8" METAL STUDS.

TYPE S6.a NON-RATED

(STC 45) ONE LAYER 5/8" GWB EACH SIDE OF 6" METAL STUDS.

TYPE S8.a NON-RATED

(STC 45) ONE LAYER 5/8" GWB EACH SIDE OF 8" METAL STUDS.

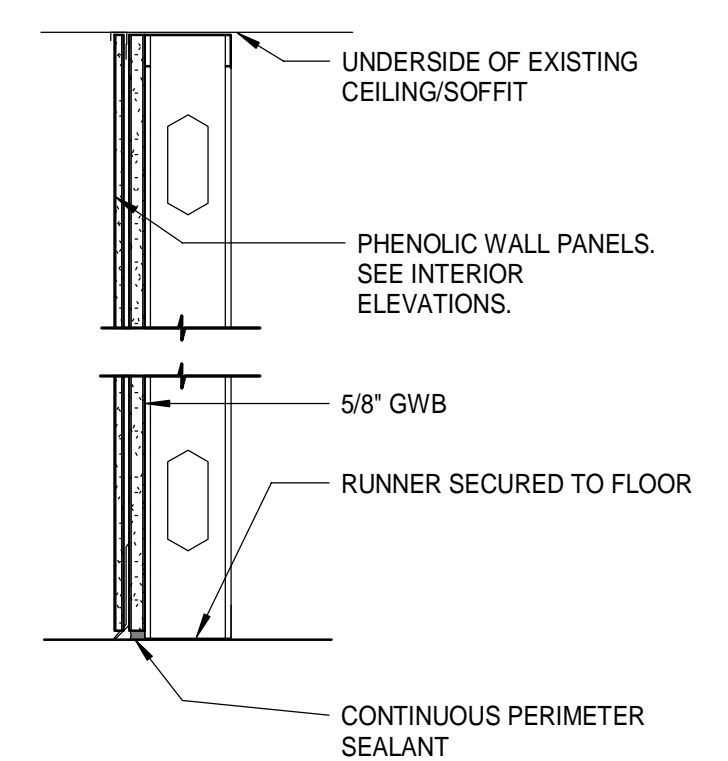

TYPE F3.b NON-RATED

(STC 45) PHENOLIC WALL PANEL TAGGED SIDE OF 3 5/8" METAL STUDS.

TYPE F6.b NON-RATED

(STC 45) PHENOLIC WALL PANEL TAGGED SIDE OF 6" METAL STUDS.

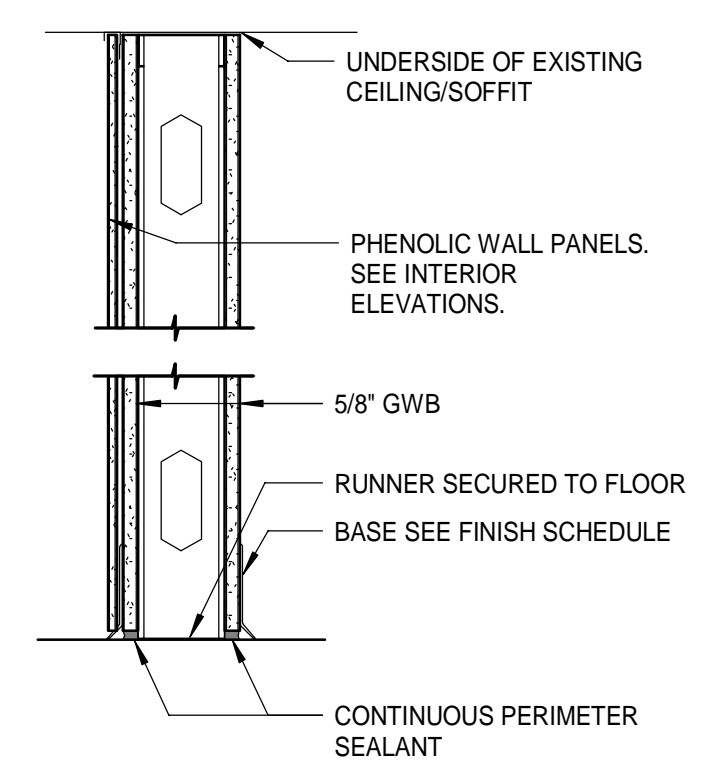

TYPE S3.b NON-RATED

(STC 45) PHENOLIC WALL PANEL TAGGED SIDE, ONE LAYER 5/8" GWB OF 3 5/8" METAL STUDS.

TYPE S6.b NON-RATED

(STC 45) PHENOLIC WALL PANEL TAGGED SIDE, ONE LAYER 5/8" GWB OF 6" METAL STUDS.

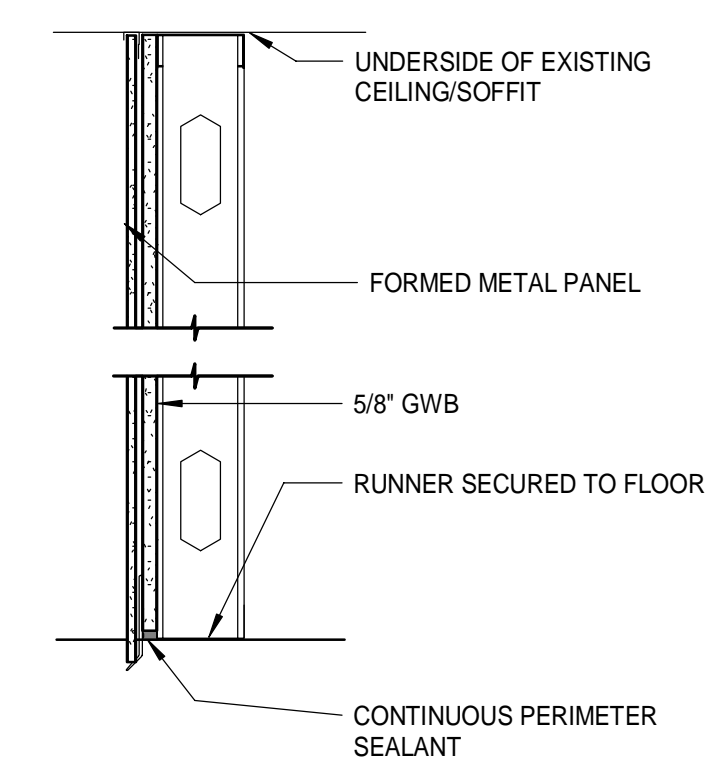

TYPE F3.c NON-RATED

(STC 45) FORMED METAL WALL PANEL TAGGED SIDE OF 3 5/8" METAL STUDS.

TYPE F6.c NON-RATED

(STC 45) FORMED METAL WALL PANEL TAGGED SIDE OF 6" METAL STUDS.

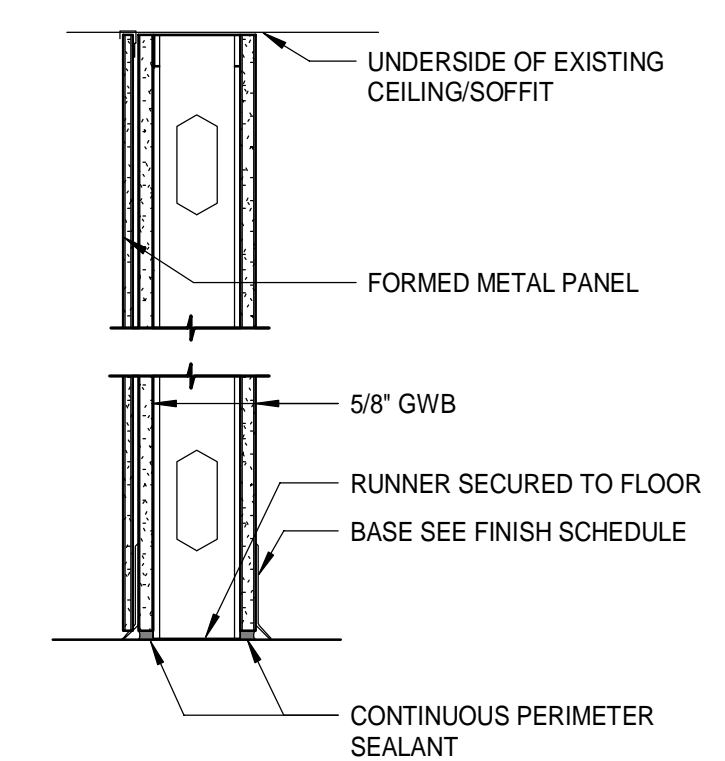

TYPE S3.c NON-RATED

(STC 45) FORMED METAL WALL PANEL TAGGED SIDE, ONE LAYER 5/8" GWB OF 3 5/8" METAL STUDS.

TYPE S6.c NON-RATED

(STC 45) FORMED METAL WALL PANEL TAGGED SIDE, ONE LAYER 5/8" GWB OF 6" METAL STUDS.

4 1 WALL TYPES
 1 1/2" = 1'-0"