

DOOR NOTES

- ALL SWINGING DOORS TO BE 1 3/4" THICK UNLESS NOTED OTHERWISE.

DOOR ABBREVIATIONS

- ACRO ACROVYN
- AL ALUMINUM
- FG FIBERGLASS
- HF HIDDEN FRAME
- HM HOLLOW METAL
- IN INSULATED
- SF STOREFRONT
- SS STAINLESS STEEL
- TEMP TEMPERED GLASS
- WIRE WIRED GLASS

DOOR AND FRAME SCHEDULE P 1															
DOOR #	DOOR					GLAZ	FRAME					HARDWARE SET	FIRE RATING	DOOR NUMBER	REMARKS
	WIDTH	HEIGHT	THICK	MAT'L	ELEV		MAT'L	ELEV	HEAD	JAMB	SILL				
2300Ca	4'-0"	7'-0"	0'-1 3/4"	SS	F	-	SS	3	1.AE601/1	1.AE601/2		1	-	2300Ca	
2300Cb	4'-0"	7'-0"	0'-1 3/4"	SS	F	-	SS	3	1.AE601/1	1.AE601/2		1	-	2300Cb	
2300Da	4'-0"	7'-0"	0'-1 3/4"	SS	F	-	SS	3	1.AE601/1	1.AE601/2		1	-	2300Da	
2300Db	4'-0"	7'-0"	0'-1 3/4"	SS	F	-	SS	3	1.AE500/3	1.AE500/4		2	-	2300Db	

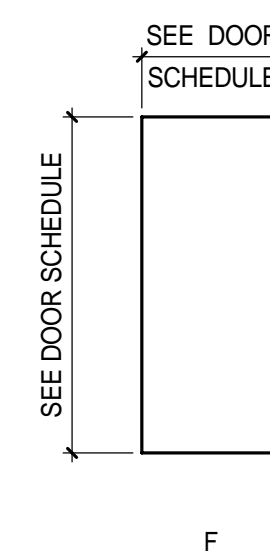

4 TYPE DOOR LEAF
1/4" = 1'-0"

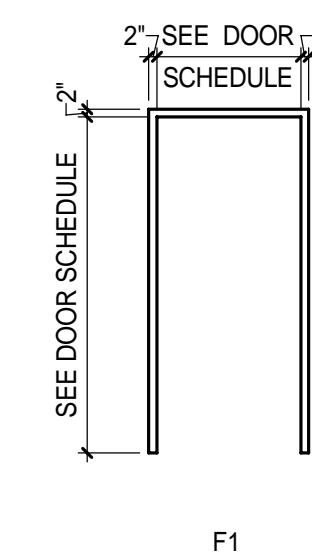

3 TYPE DOOR FRAME
1/4" = 1'-0"

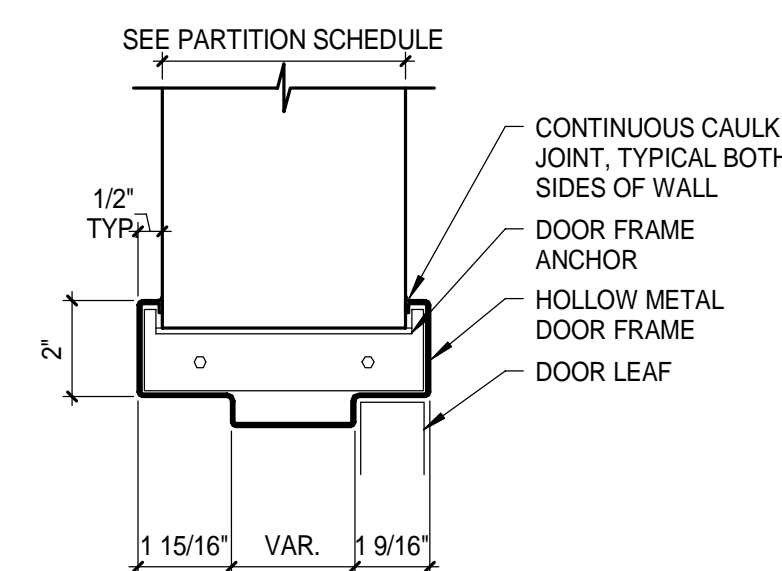

2 DOOR HEAD DETAIL
3" = 1'-0"

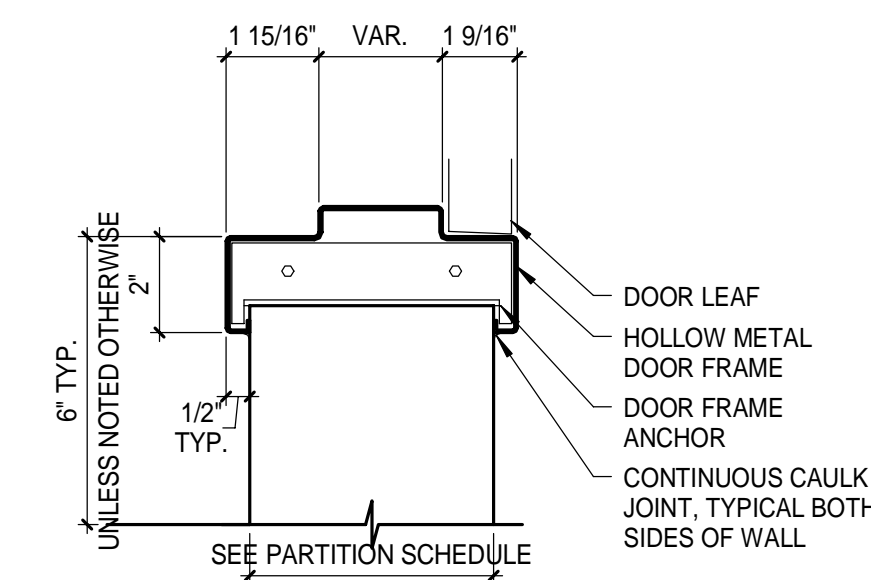

1 DOOR JAMB DETAIL
3" = 1'-0"

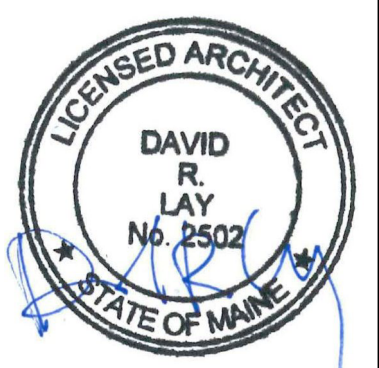

ARCHITECTURE 144 Fore Street P.O. Box 618
Portland, Maine 04104
tel. (207) 775-3846
fax. (207) 775-1070
www.srmtinc.com

SMART
ENGINEERING
PLANNING
INTERIORS
ENERGY

SMRT PROJECT NO. | PROJECT MGR | JCDRAWN | A/E OF RECORD
17033 | DFL | Author | Checker

REV.	BY:	DATE:	ISSUED FOR CONSTRUCTION	STATUS:
0		12/21/17		

THIS PLAN SHALL NOT BE MODIFIED WITHOUT WRITTEN PERMISSION FROM SEBAGO TECHNICS, INC.
USERS ASSUME ALL RISK AND LIABILITY TO SEBAGO TECHNICS, INC.

SEBAGO TECHNICS
WWW.SEBAGOTECHNICS.COM
75 John Roberts Rd., Suite 1A 250 Goddard Rd., Suite B
South Portland, ME 04086 Portland, ME 04106
Tel: (207) 200-2100 Fax: (207) 783-5660

PROJECT NO. | FIELD BOOK | DESIGN | CHKD | DRAWN

DOOR SCHEDULE AND DETAILS
OF:
**PORTLAND INTERNATIONAL JETPORT
GATE UPGRADES**
1001 WESTBROOK STREET
PORTLAND, MAINE 04102

DATE	SCALE
12/21/17	As indicated

1.AE601