

ARCHITECTURE 144 Fore Street P.O. Box 618
 Portland, Maine 04104
 Tel: (207) 772-3846
 Fax: (207) 772-1070
 www.srmtinc.com

ENGINEERING
 PLANNING
 INTERIORS
 ENERGY

SMRT PROJECT NO. PROJECT MGR. JCDRAWN JAE OF RECORD
 DRL
 MOH
 DRL
 17033

ISSUED FOR CONSTRUCTION
 STATUS: DATE: 12/21/17
 BY: 0
 REV: 0

THIS PLAN SHALL NOT BE MODIFIED WITHOUT WRITTEN PERMISSION FROM SEBAGO TECHNICS, INC.
 USER'S ASSUMES ALL RISK AND WITHOUT LIABILITY TO SEBAGO TECHNICS, INC.

SEBAGO TECHNICS
 WWW.SEBAGOTECHNICS.COM
 75 John Roberts Rd., Suite 1A
 250 Goddard Rd., Suite B
 South Portland, ME 04086
 Tel: (207) 772-3846
 Fax: (207) 772-1070

PROJECT NO. FIELD BOOK DESIGN CHKD DRAWN
 PROJECT MGR. JCDRAWN JAE OF RECORD
 DRL
 MOH
 DRL

DETAILS - CASEWORK
 OF:
 PORTLAND INTERNATIONAL JETPORT
 VERTICAL CIRCULATION IMPROVEMENTS
 1001 WESTBROOK STREET
 PORTLAND, MAINE 04102

DATE SCALE
 12/21/17 As indicated

2.AE520

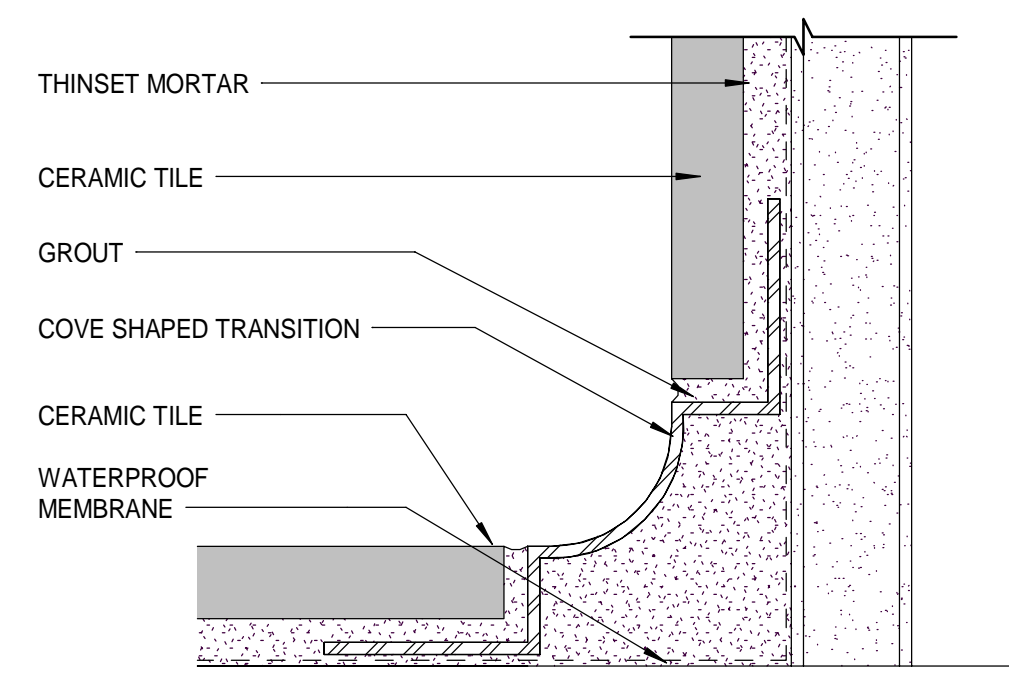

11 DETAIL @ TILE COVE
 6" = 1'-0"

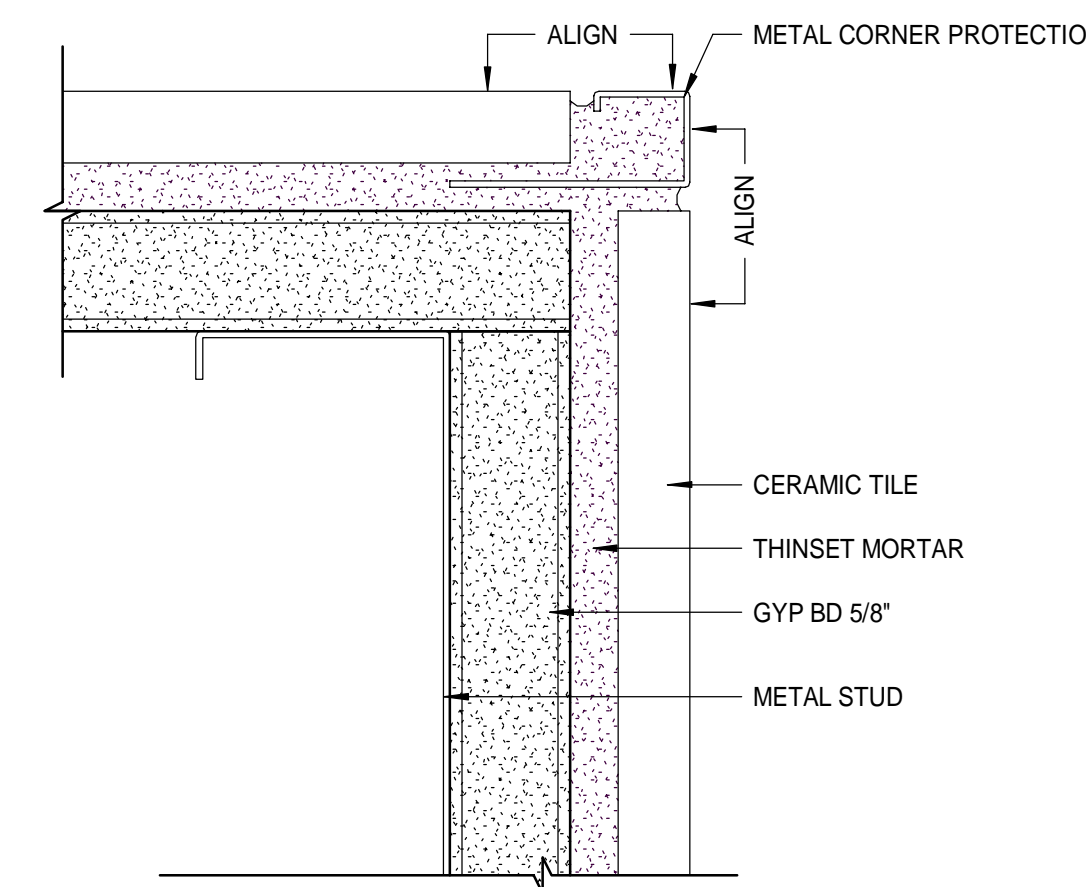

10 PLAN @ CT-02 OUTSIDE CORNER
 12" = 1'-0"

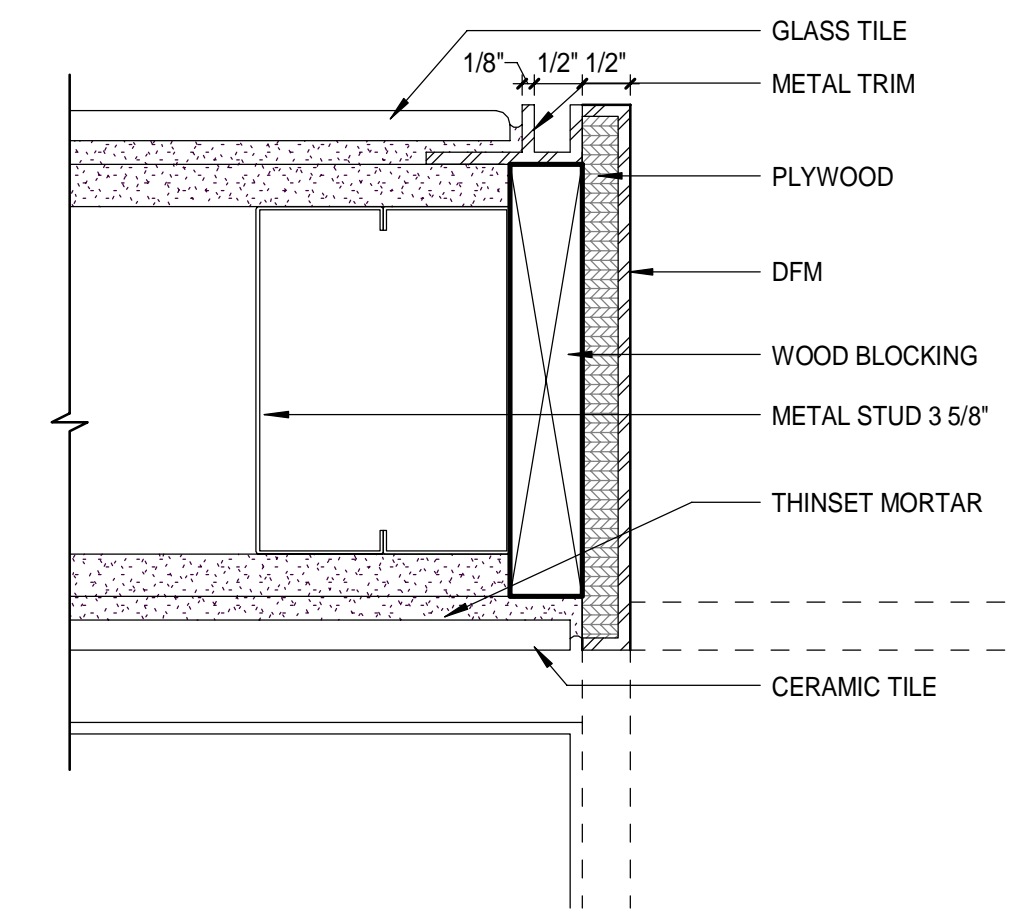

9 PLAN @ GLASS TILE/CERAMIC TILE
 6" = 1'-0"

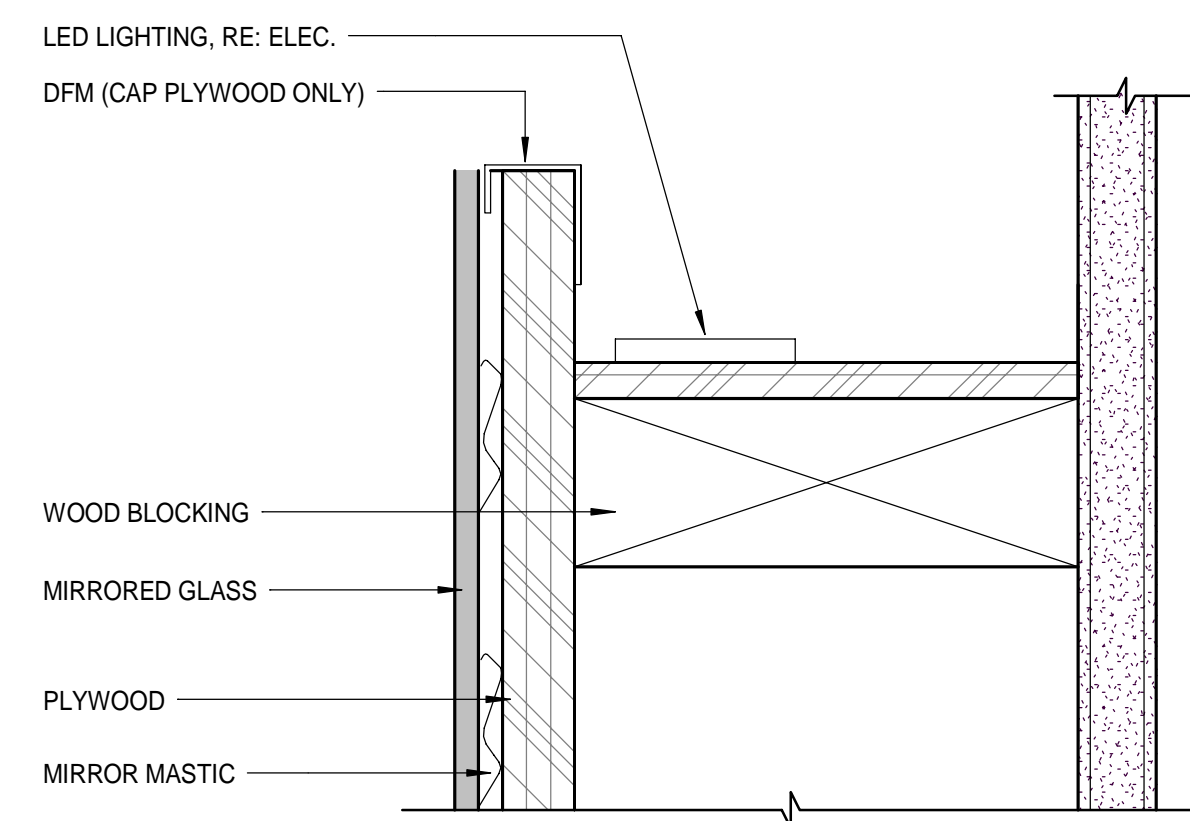

7 DETAIL @ MIRROR HEAD
 6" = 1'-0"

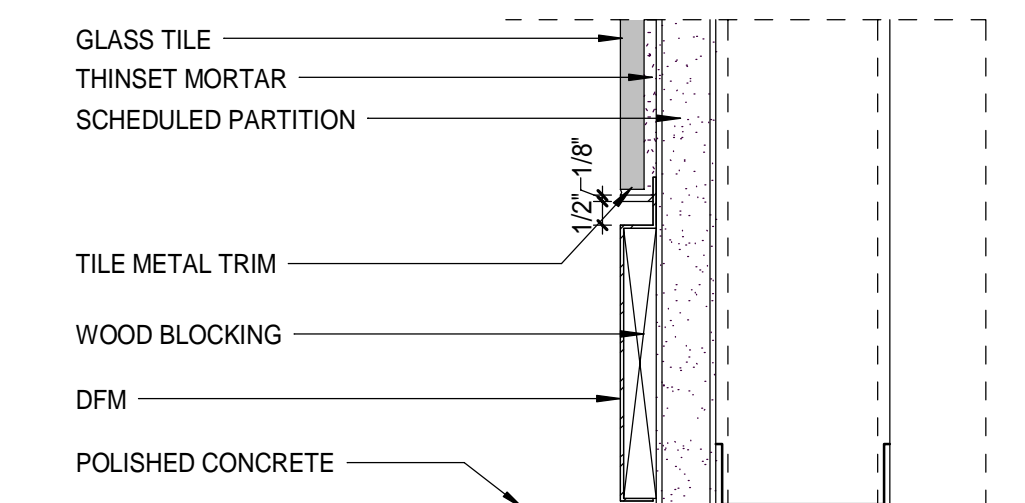

6 DETAIL @ METAL BASE/GLASS TILE
 3" = 1'-0"

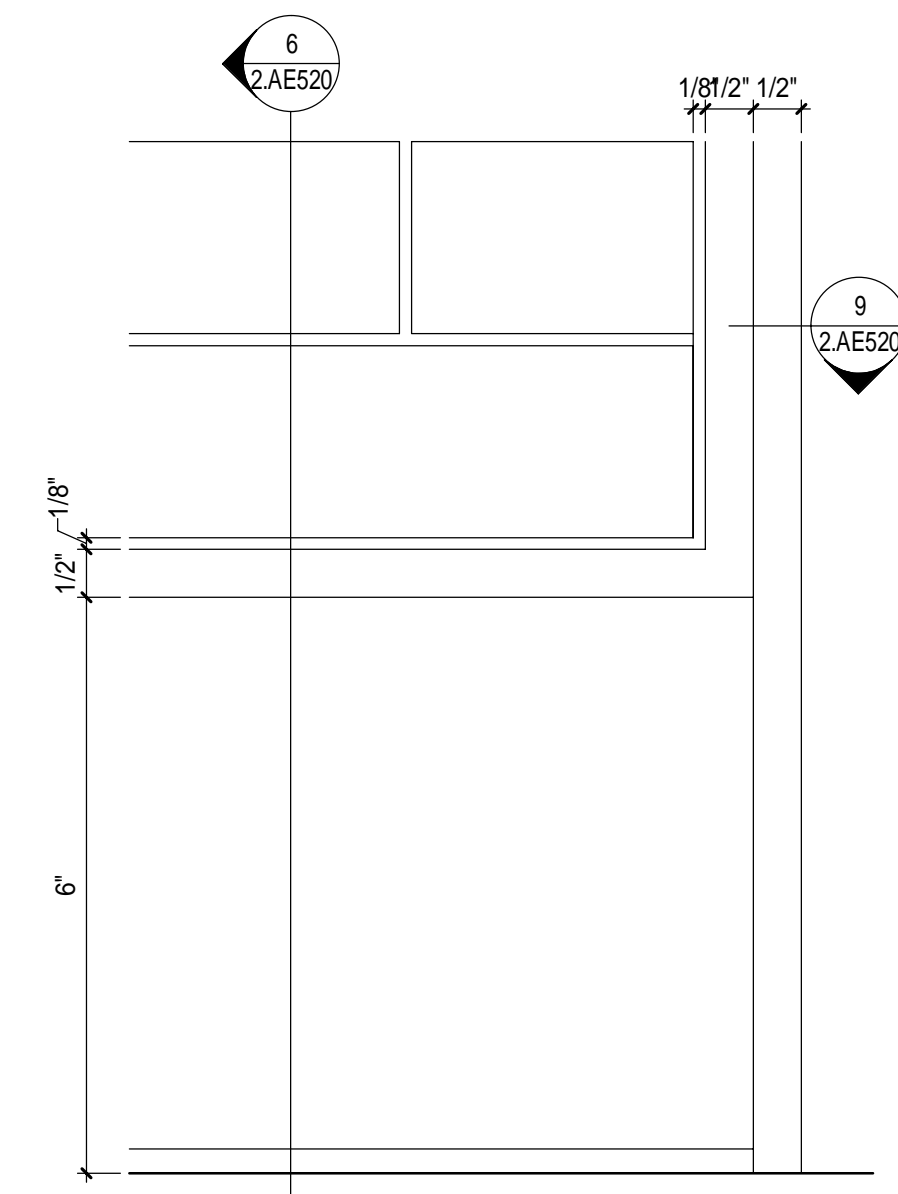

5 ELEV @ METAL BASE @ GLASS TILE
 6" = 1'-0"

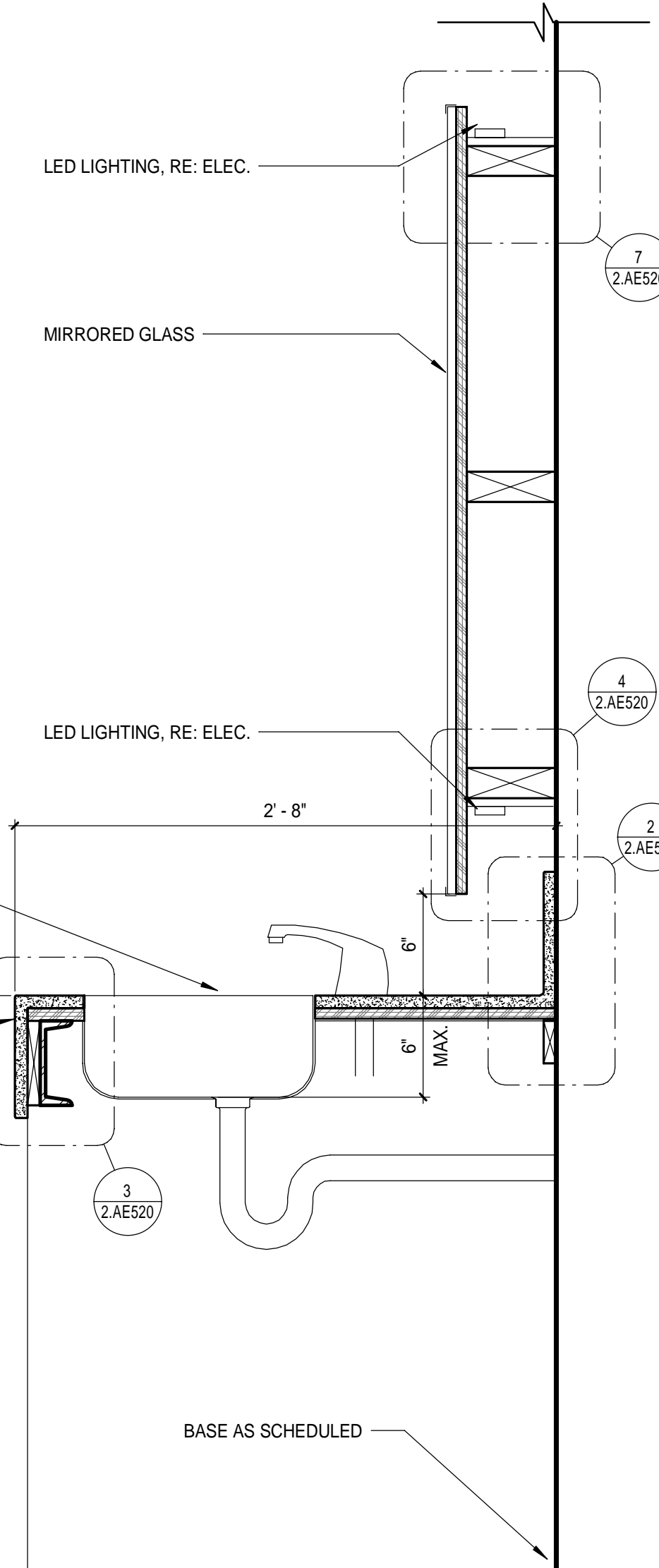

1 SECTION @ LAVATORY
 1 1/2" = 1'-0"

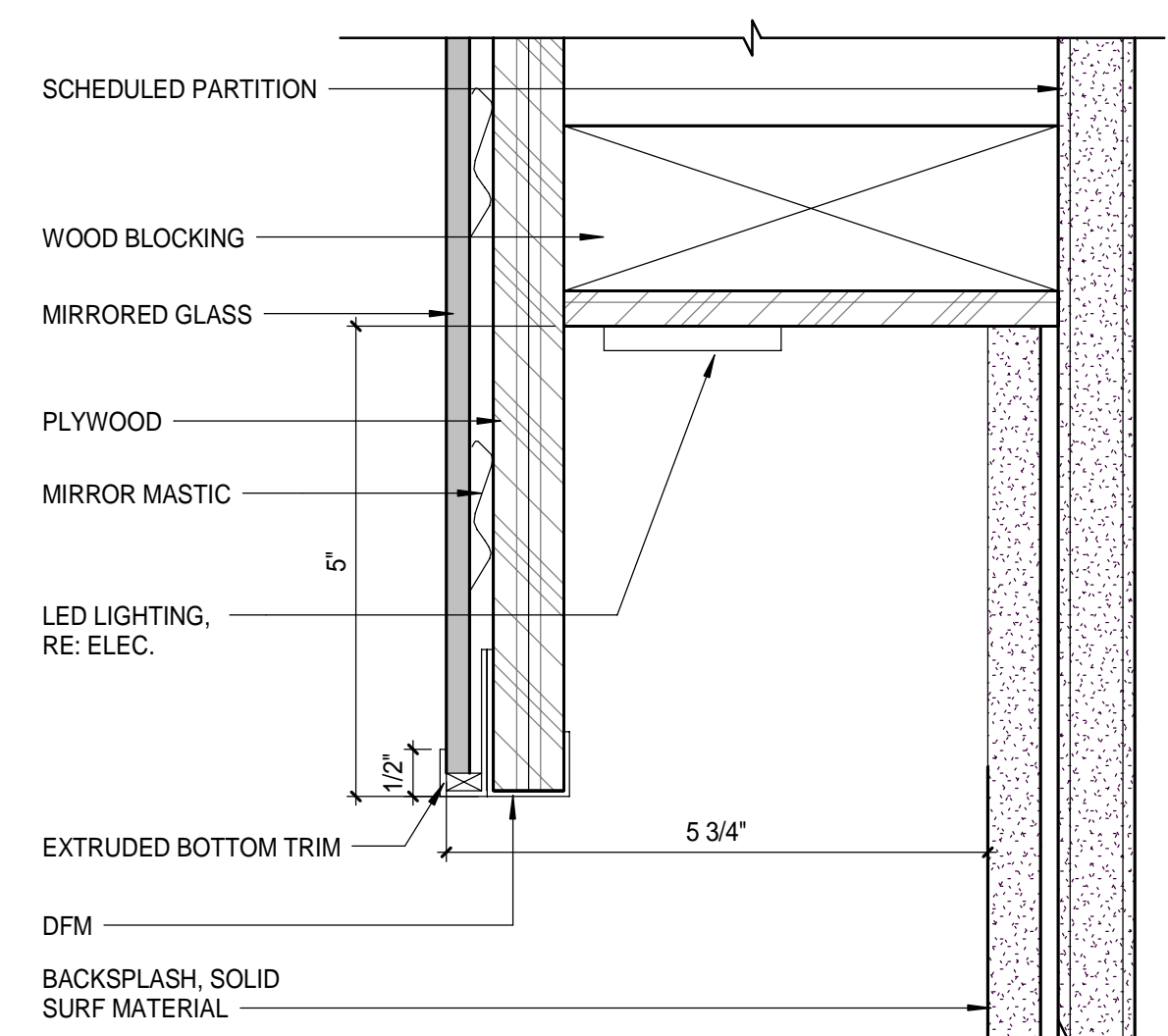

4 DETAIL @ MIRROR BASE
 6" = 1'-0"

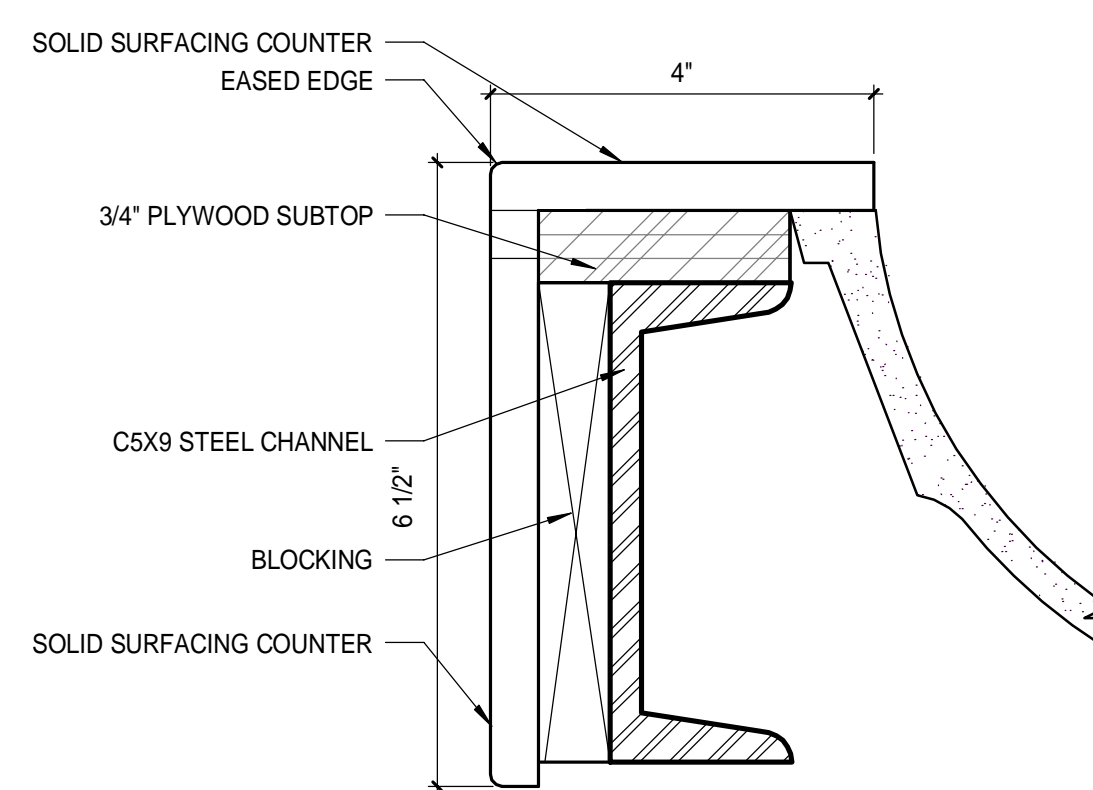

3 COUNTER EDGE DETAIL
 6" = 1'-0"

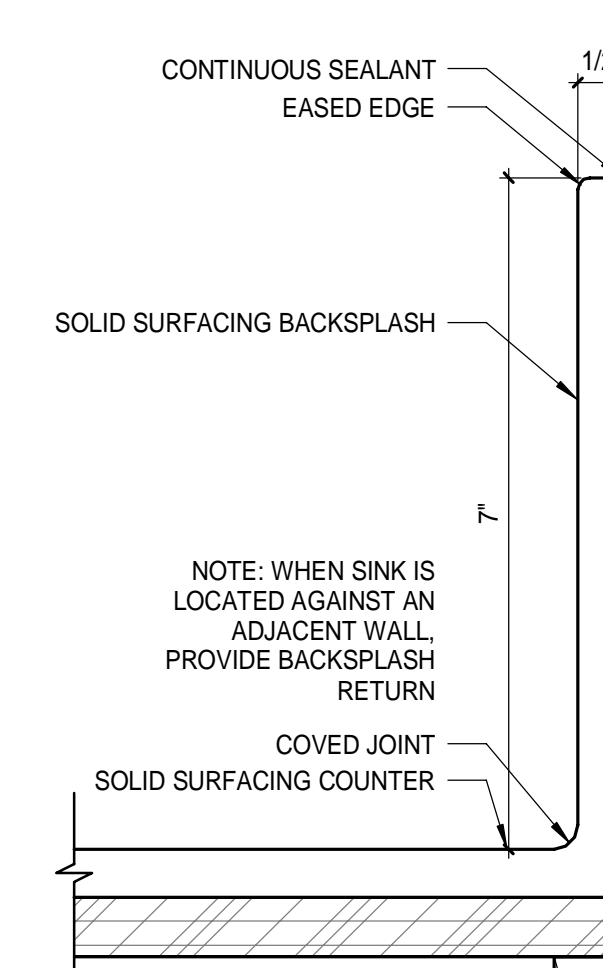

2 BACKSPLASH DETAIL
 6" = 1'-0"