

EXHAUST FAN INFORMATION - Job#2002290

FAN UNIT NO.	TAG	FAN UNIT MODEL #	CFM	ESP.	RPM	H.P.	Ø	VOLT	FLA	WEIGHT (LBS.)	SDNES
1		DUI2HFA	350	0.250	1163	0.180	1	115	2.0	65	5.2

FAN OPTIONS

FAN UNIT NO.	TAG	OPTION (Qty. - Descr.)
1		1 - Grease Box
		1 - Wallmount 18.5" sq. x 2"
		1 - 3 Year Extended Motor Warranty
		1 - Fan Base Ceramic Seal - For Grease Ducts
		1 - Low Profile Option - 12.

FAN ACCESSORIES

FAN UNIT NO.	TAG	EXHAUST			SUPPLY			
		GREASE CUP	GRAVITY DAMPER	WALL MOUNT	SIDE DISCHARGE	GRAVITY DAMPER	MOTORIZED DAMPER	WALL MOUNT
1		YES		YES				

FAN #1 DUI2HFA - EXHAUST FAN

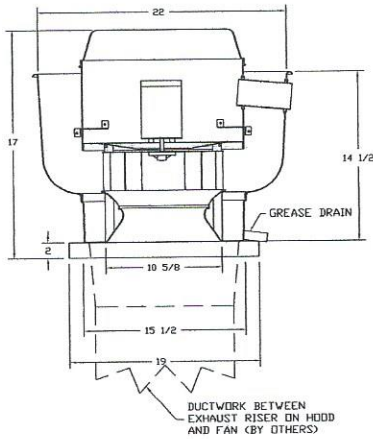

FEATURES:

- ROOF MOUNTED FANS
- RESTAURANT MODEL
- UL705 AND UL762
- VARIABLE SPEED CONTROL
- INTERNAL WIRING
- WEATHERPROOF DISCONNECT
- THERMAL OVERLOAD PROTECTION (SINGLE PHASE)
- HIGH HEAT OPERATION 300°F (149°C)
- GREASE CLASSIFICATION TESTING

NORMAL TEMPERATURE TEST
EXHAUST FAN MUST OPERATE CONTINUOUSLY WHILE EXHAUSTING AIR AT 300°F (149°C) UNTIL ALL FAN PARTS HAVE REACHED THERMAL EQUILIBRIUM, AND WITHOUT ANY DETERIORATING EFFECTS TO THE FAN WHICH WOULD CAUSE UNSAFE OPERATION.

ABNORMAL FLARE-UP TEST
EXHAUST FAN MUST OPERATE CONTINUOUSLY WHILE EXHAUSTING BURNING GREASE VAPORS AT 600°F (316°C) FOR A PERIOD OF 15 MINUTES WITHOUT THE FAN BECOMING DAMAGED TO ANY EXTENT THAT COULD CAUSE AN UNSAFE CONDITION.

OPTIONS

- GREASE BOX
- WALLMOUNT 18.5" SQ. X 2"
- 3 YEAR EXTENDED MOTOR WARRANTY
- FAN BASE CERAMIC SEAL - FOR GREASE DUCTS
- LOW PROFILE OPTION - 12.

WALL MOUNT BRACKET

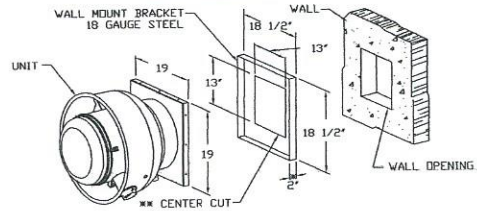

- WALL BRACKET FITS INTO BASE OF FAN
- SELF DRILLING SCREWS SHOULD BE USED FOR UNIT ATTACHMENT TO WALL MOUNT BRACKET
- DIMENSION = 5" WHEN USED WITH DAMPER
- CENTERED IN WALL MOUNT

CUSTOMER APPROVAL TO MANUFACTURE:

Approved as Noted
 Approved with NO Exception Taken
 Revise and Resubmit
 SIGNATURE *John Lecker*
 Your Title _____ Date _____



JOB Portland Jetport	
LOCATION Biddeford, ME.	
DATE 7/29/2014	JOB # 2002290
DWG # 3	DRAWN BY BFC-21
REV.	SCALE 3/8" = 1'-0"