



Operation, Installation, and Maintenance Manual

LW401

Fire Alarm System Control Unit

P/N 315-095997FA-2
(446106)

Faraday: www.faradayfirealarms.com
Copyright ©1997, Faraday, LLC All Rights Reserved

Table of Contents

<i>Section</i>	<i>Page</i>
1 INTRODUCTION	1
Standard Components	2
MAIN BOARD	2
DISPLAY	2
FRONT PANEL FUNCTIONS	3
2 INSTALLATION	5
Unpacking the Equipment	5
Installing the Control Panel	6
3 OPERATING MODES	9
Alarm	9
Supervisory	9
Zone Trouble	9
SYSTEM TROUBLE (FAULT) CODES	9
Normal	9
Program/Test	9
Responding to a Fire Alarm	9
HOW THE SYSTEM ANNUNCIATES FIRE ALARMS	9
TO ACKNOWLEDGE ALARMS	10
TO SILENCE THE NOTIFICATION APPLIANCE CIRCUITS	10
TO RESET	10
Responding to a Supervisory Condition	10
HOW THE SYSTEM ANNUNCIATES SUPERVISORIES	10
TO ACKNOWLEDGE SUPERVISORIES	10
TO RESET	10
Responding to a Trouble Condition	10
HOW THE SYSTEM ANNUNCIATES TROUBLES	10
TO ACKNOWLEDGE TROUBLES	11
TO RESET	11
System Features	11
INITIATING DEVICE CIRCUIT (ZONE) TYPES	11
ALARM VERIFICATION	11
GENERIC ZONE	12
NOTIFICATION APPLIANCE CIRCUIT (NAC OR BELL CIRCUIT TYPE)	12
<i>Simple Zone Code</i>	12
SET OUTPUT CONTROL MATRIX	13
BYPASS ZONES AND OUTPUTS	13
SET SYSTEM TIMING	13
ALARM VERIFICATION RETARD/RESET TIMER SELECTION	13
SET SYSTEM PASSWORD	14
SET AC FAIL SIGNAL DELAY	14
ENABLE SYSTEM OPTION CARDS	14
ONE PERSON SYSTEM TEST	14
LAST EVENT RECORD	15
Program Mode	15
PROGRAM LEVEL DESCRIPTIONS	15

Table of Contents (Cont.)

<i>Section</i>	<i>Page</i>
ENABLING THE PROGRAM MODE	16
<i>Enter Password</i>	16
<i>Reading the LW-401 Display</i>	16
<i>To Select Program Mode</i>	16
<i>To Exit Program Mode</i>	16
Test Mode	20
<i>Reading the LW-401 Display</i>	20
TEST LEVEL DESCRIPTIONS	20
ENABLING THE TEST MODE	20
<i>Enter Password</i>	20
<i>To Select Test Mode</i>	20
<i>To Exit Test Mode</i>	21
4 CHECKOUT PROCEDURE	25
Maintenance	25
PERIODIC INSPECTION AND TESTING	25
SERVICING	25
FIELD WIRING CHECKOUT PROCEDURE	27

List of Illustrations

<i>Figure</i>	<i>Page</i>
1. LW-401 Control Panel	1
2. LW-401 Front Panel	2
3. LW-401 Enclosure	5
4. Transformer Mounting	6
5. Mounting the Standoffs and Spacers	6
6. Mounting the LW41-MB	7
7. Line Graph of Alarm Verification	12

List of Tables

1. Program Mode Levels	23
2. Test Mode Levels	24
3. System Fault Troubleshooting	25
4. Electrical Requirements for Battery Calculations and Power Management	26
5. Field Wiring Checkout Procedure	27
6. Default Configurations	28
7. Programming Sheet	29

1

INTRODUCTION

The LW-401 is a microprocessor based fire and life safety system with four conventional initiating device circuits (up to 8 with the addition of the optional LWZE-4A or LWZE-8A zone expander). All basic alarm and trouble functions are annunciated and controlled from the LW-401 front panel (See Figure 1) which consists of:

- Seven segment numeric display
- Four user-control switches
- Red and yellow LEDs for each of the eight zones
- Six system status LEDs

Key features of the LW-401 are:

- 2 Class B (Style Y) +24 VDC notification appliance circuits (NACs) rated at 1.5 amps each.
- Silenceable/Non-Silenceable notification appliance circuits (NACs).
- Fully supervised initiating and notification circuits.
- Initiating and notification circuits power limited.
- 4 Class B (Style B) 2 wire initiating device circuits that are expandable to 8 circuits.
- Supports up to 30 non-shorting devices per initiating device circuit.
- Selectable alarm verification option for each initiating device circuit.
- One person system test with or without audible confirmation.
- User-alterable factory installed configuration.
- One Form C system Alarm relay
- One Form C system Trouble relay
- Seven segment numeric status display
- Six LED status indicators
- Easy-to-use front panel function keys

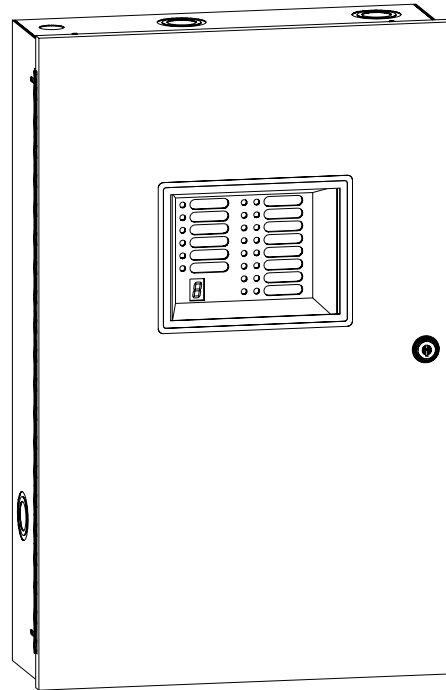

Figure 1
LW-401 Control Panel

- Alarm Coding (March Time, Temporal, or Simplified Zone Code) and Non-Silenceable output option.
- Easy-to-use built-in diagnostics.
- 24 hour re-sound for Alarm and Trouble conditions that are not restored to normal after being acknowledged.
- Optional LWZE-8A module converts the system to four Class A (Style D) Initiating Device Circuits and two Class A (Style Z) Notification Appliance Circuits and also provides four additional Class A (Style D) Initiating Device Circuits.
- Optional LWZR-8 module provides eight programmable Form C relays.
- Optional LWRA-8B/W module provides remote annunciation for eight zones with 16 LEDs. Up to two may be used.
- Optional LWCT-1 module provides Leased Line/Municipal Tie connection.

Standard Components

A standard four zone LW-401 has one module—the main board. An expander board is added to provide four additional zones, when needed.

MAIN BOARD

The Main board of the LW-401 contains the intelligence for the system and performs all of the input/output processing as listed below:

- **Two supervised Notification Appliance Circuits** provide 24 VDC at 1.5 amps. Each circuit operates Class B (Style Y) and can be independently programmed to operate a number of different ways (Non-Coded, March Time, Temporal, or Simple Zone Code).
- **Two Form C relays** rated at 30 VDC at 1 amp resistive, 30 VAC at 500mA resistive. These relays are for Alarm and Trouble operation.
- **A dual mode battery charger** that provides float and constant current modes of charging sealed lead acid batteries (15 Amp-Hour maximum).
- **Nonvolatile storage of system configuration** so that configuration remains intact during loss of system power.
- **Four supervised power limiting Initiating Device Circuits.** Each circuit operates Class B (Style B) and can be independently programmed to operate as an Automatic Alarm input, a Verified Alarm input, a Supervisory input, or a Generic input. Each initiating device circuit can use an unlimited number of manual shorting-type devices.
- **CPU Fail LED.**

DISPLAY

The LW-401 display, shown in Figure 2, provides the user with the necessary interface to operate the fire detection system in Normal, Test, and Program modes.

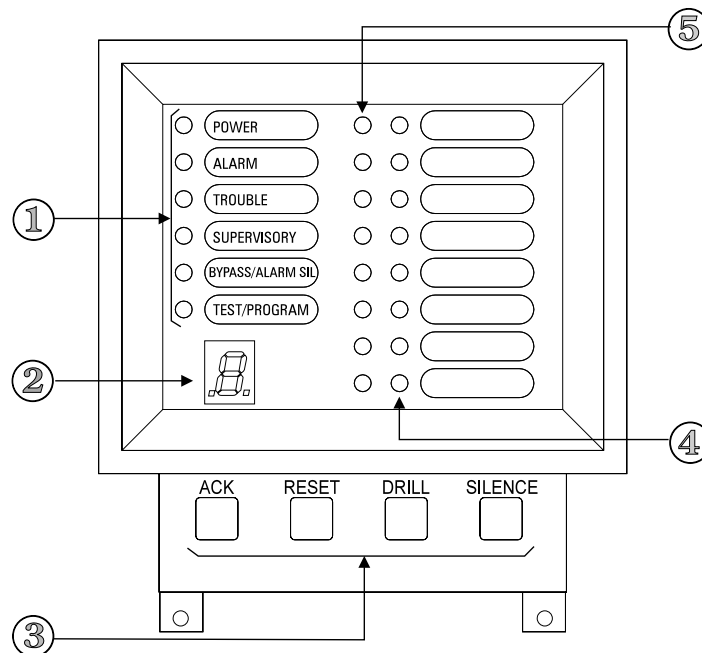

Figure 2
LW-401 Front Panel

FRONT PANEL FUNCTIONS

The front panel of the LW-401 is comprised of a seven segment display, function keys, and LEDs. Their functions are described below (Refer to Figure 2):

① The LEDs

The green **Power LED** remains on steady when AC power is connected and pulses when the unit is operating from batteries.

The red **Alarm LED** pulses when an alarm is detected until it is acknowledged. Then it remains on steady until the alarm condition is reset.

The yellow **Supervisory LED** pulses when a supervisory condition is detected until it is acknowledged. Then it remains on steady until the supervisory condition is reset. Note that the pulsing rates of the trouble and supervisory conditions are different.

The yellow **Trouble LED** pulses when a trouble condition is detected until it is acknowledged. Then it remains on steady until the trouble condition is reset. Note that the pulsing rates of the trouble and supervisory conditions are different.

The yellow **Bypass/Alarm Silence LED** is on steady when a zone in the system is bypassed and it pulses when a notification circuit is silenced. When an initiating device zone is bypassed, the appropriate yellow zone trouble LED is on.

The **Test/Program LED** is on steady when the Test mode is selected and it pulses when the Program mode is selected.

The Sounder

CONDITION	RATE OF PULSATION
SYSTEM ALARM	Sounds steady
TROUBLE	Pulses at 50% duty cycle
SUPERVISORY	Pulses at 25% duty cycle
CPU FAILURE	Pulses once every 2 seconds

② **The seven segment display** indicates the various system troubles and the programming and test modes. The numbers and symbols that appear on this display are described in the following chart.

CODE	DESCRIPTION
1	AC power fail
2	NAC 1 trouble
3	NAC 2 trouble
4	Ground fault
5	Municipal tie fault
6	Battery fault
7	System Configuration fault
8	Auxiliary port fault
9	Outputs bypassed
0	Hardware failure
E	Enter password
A	Password accepted
F	Password fail
P	Program mode
t	Test mode
L	Leave Program/Test mode

③ The Function Keys

The ACK key is used to acknowledge alarms, troubles, and supervisory conditions. In general the LEDs change from pulsing to steady to indicate that the condition was acknowledged.

The SILENCE key silences the notification appliance circuits that are configured as silenceable. Pressing the SILENCE key a second time causes the NACs to re-sound.

The RESET key resets the LW-401 and all of the smoke detectors.

The DRILL key activates all of the notification appliance circuits.

④ **The yellow zone status LEDs** indicate a trouble or supervisory condition existing on a particular input. Pulsing indicates the condition was not acknowledged; on steady indicates it was acknowledged.

⑤ **The red zone status LEDs** provide an indication of the status of a particular zone. Pulsing indicates an alarm condition in that zone. When the alarm is acknowledged, the LED remains on steady until the panel is reset.

2

INSTALLATION

Unpacking the Equipment

The LW-401 is shipped in two cartons; one of the cartons contains the LW-401 enclosure. The other carton contains the LW-401 electronics, the transformer, and the mounting hardware. Follow the procedure below to unpack the LW-401 equipment.

1. Locate and open the shipping carton containing the LW41-EN enclosure. Remove the packing material and inspect the enclosure for damage.
Note: If the enclosure is damaged, contact the shipping carrier immediately to report the damage.
2. Locate and open the shipping carton containing the LW-401 electronics.

Remove the packing material, and inspect the electronics for damage.

Note: If the PC board is damaged, contact the shipping carrier immediately to report the damage.

3. Check that the following items are inside the carton:
 - Mounting hardware for the LW41-MB and transformer
 - Main board
 - Power transformer**Note:** If any of the above items are missing, contact the distributor from whom you ordered the unit.

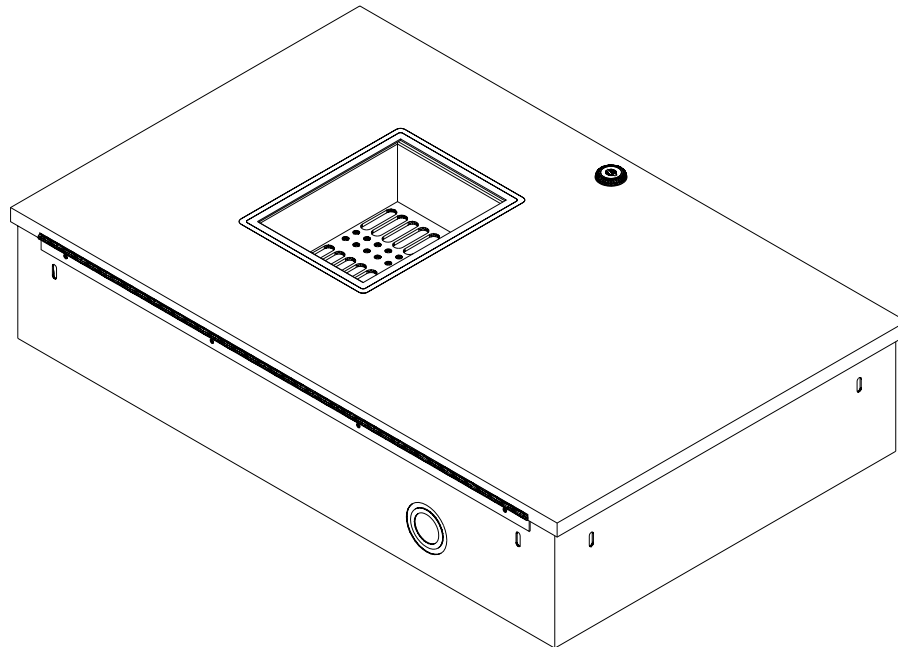

Figure 3
LW-401 Enclosure

Installing the Control Panel

Remove all system power before installation, first battery and then AC.

(To power up, connect the AC first, then the battery.)

All wiring must comply with national and local codes.

Install the LW-401 control panel by following the steps listed below.

- 1. Install the enclosure.** Fasten the enclosure securely to a clean, dry, shock and vibration free surface. Consider the following placement factors when mounting the enclosure: height as it relates to the front panel, weight and size of the enclosure, and local mounting codes. Refer to the *LW41-EN Installation and Power Limited Wiring Instructions*, P/N 446107, for further information.

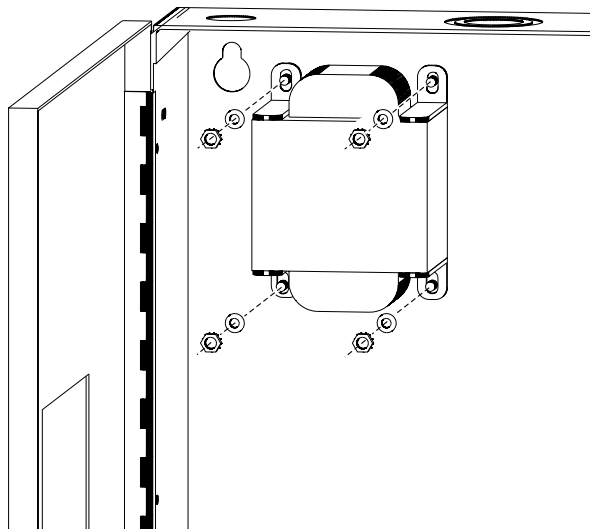

Figure 4
Transformer Mounting

- 2. Fasten the power transformer to the inside of the enclosure.** Mount the transformer on the four studs in the upper left-hand corner of the LW41-EN enclosure, as shown in Figure 4, using the hardware provided.
- 3. Pull all field wiring into the enclosure.** Dress the wiring to the approximate location to which it will go on the LW41-MB.
- 4. Install the PC Board mounting metal hex standoffs and plastic spacers.** Mount the six PC Board metal hex standoffs and two plastic round spacers, as shown in Figure 5.
- 5. Install the Main board.** Mount the Main board to the standoffs in the center of the enclosure (Refer to Figure 6).
 - a.** Fasten two of the six screws provided in the PC board mounting hardware in the two bottom metal hex standoffs

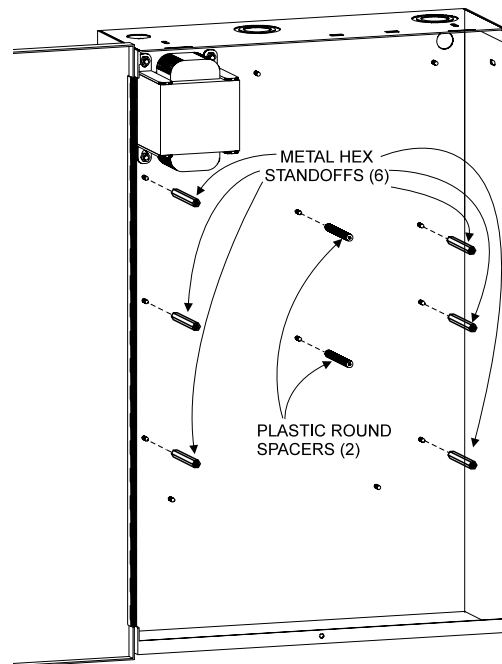

Figure 5
Mounting the Standoffs and Spacers

- labeled **A** in Figure 6, leaving a 1/4 inch gap between the standoff and the head of the screw.
- b. Place the slots on the bottom of the LW41-MB on the two screws.
 - c. Secure the board in place by fastening the remaining four screws labeled **B** to the metal hex standoffs.
 - d. Tighten the bottom two screws.
6. **Optional modules.** Refer to the specific optional module Installation Instruction sheet for the appropriate installation.
 7. **Before connecting any wire to its screw terminal, refer to the Checkout Procedure** (page 27) **and the LW-401 Connection Diagram**, P/N 315-096185FA. Prior to connecting wiring to the Main board, ensure compliance to maximum resistance in accordance with the Field Wiring Checkout procedure, page 27. Make sure that all power is off before connecting leads.
 8. **Install power wiring.** The LW-401 is designed to operate from a 120 VAC, 60 Hz power source.

Use a dedicated circuitbreaker. Wire in accordance with local codes and/or Article 760 of the National Electrical Code, NFPA 72, latest edition.

- a. Run Earth Ground from a suitable source to the Earth Ground stud on the chassis (See Figure 6 for the location of the stud). Secure in place using the two #8 nuts provided. Check local requirements. **Conduit is not an acceptable ground.**
- b. Connect the 120 VAC source and the **BLACK** transformer wire leads to TB1.
- c. Connect the **BROWN** transformer wire leads to TB6.

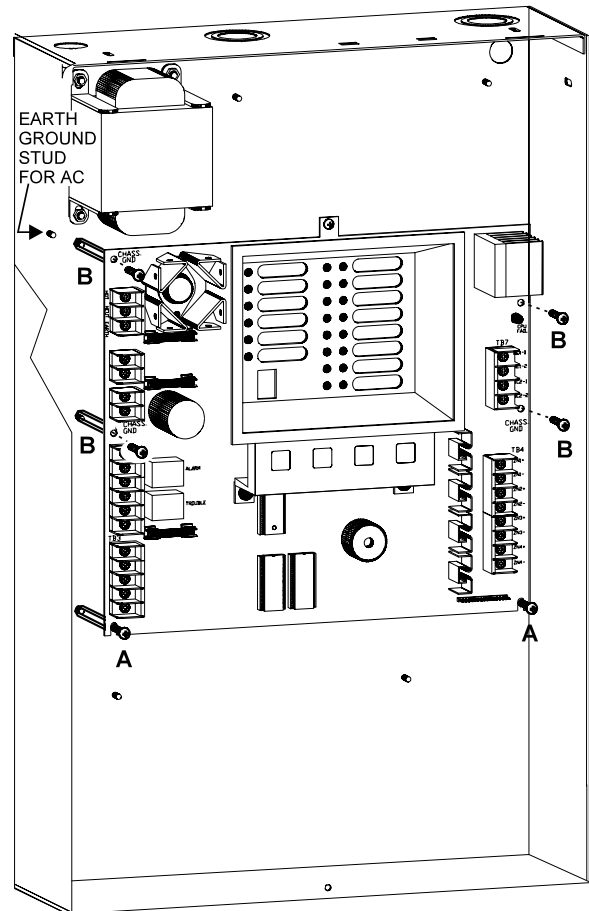

Figure 6
Mounting the LW41-MB

3

OPERATING MODES

The LW-401 annunciates the following modes of operation:

- Alarm
- Supervisory
- Trouble
- Normal
- Program/Test

Alarm

The LW-401 Display board lights the appropriate red alarm LED and the general ALARM LED to indicate to the user that an Alarm condition exists on an initiating device circuit (IDC).

Supervisory

A Supervisory alarm condition is indicated on the LW-401 by the SUPERVISORY LED flashing along with the appropriate yellow zone LED.

Zone Trouble

A Trouble condition is displayed by a flashing TROUBLE LED along with the appropriate yellow zone LEDs.

System Trouble (Fault) Codes

A number is displayed in the seven segment display to indicate System Trouble (Fault) Codes. They are:

- Code 1:** AC Power Fail/Brownout
- Code 2:** Notification Appliance Circuit 1
- Code 3:** Notification Appliance Circuit 2
- Code 4:** Ground Fault
- Code 5:** Municipal Tie Fault
- Code 6:** Battery Fault
- Code 7:** System Configuration Fault
- Code 8:** Auxiliary Port Fault
- Code 9:** Output Bypassed
- Code 0:** Hardware Failure

For a further description of the system fault codes, see **System Fault Troubleshooting** (Table 3, page 25).

Normal

The Normal Mode is the absence of any alarm, supervisory, or trouble condition. The **POWER** LED is lit in Normal mode when the system has AC power. The **Alarm, Trouble, Supervisory, Bypass, and Zone status** LEDs are off, and the internal sounder is off.

Program/Test

The Program/Test Mode is used for system configuration, test, and maintenance functions. **When the LW-401 is in Program Mode, it does not indicate alarm or supervisory conditions.**

The System resets to normal mode after 2 minutes of front panel inactivity. When the LW-401 is in the One Person System Test Mode, it automatically returns to normal mode after 20 minutes of inactivity.

Responding to a Fire Alarm

How the System Annunciates Fire Alarms

When a fire is detected on one of the initiating device circuits (IDCs), the LW-401 causes the **System ALARM** LED and the appropriate **Zone ALARM** LED on the front panel to flash and the system's internal audible to sound.

NOTE: Follow the response plan approved by the local authority having jurisdiction.

To Acknowledge Alarms

1. Unlock and open the door.
2. Press **ACK** to acknowledge (Block Acknowledge) **all** alarms and other conditions. The system **ALARM** and the **Zone ALARM** LEDs on the front panel stop flashing and remain on. The system's internal audible silences.

To Silence The Notification Appliance Circuits

Press **SILENCE** after all alarms are acknowledged. The **BYPASS** LED on the front panel flashes. The following four conditions are checked before the Notification Appliance Circuit(s) can be silenced:

1. If either NAC is programmed as **NON-SILENCEABLE**, it will not silence.
2. If the NAC inhibit timer has been programmed (see *Set System Timing* on page 13), the NAC will not silence until the inhibit time delay has expired (6 seconds to 5 minutes.)
3. If either NAC is programmed for temporal coding, it will complete sending out the entire current temporal round before silencing.
4. If either NAC is programmed for **ZONE CODING**, **all** coded rounds for **each** zone in alarm must be sent out before the NAC will silence.

Once the NACs have silenced, pressing the **SILENCE** a second time causes the Notification Appliance Circuits to re-sound, and the **BYPASS** LED to turn off.

To Reset

Press **RESET**. (The system will not reset until all alarms, supervisories, and troubles are acknowledged and all conditions are returned to normal.)

Responding to a Supervisory Condition

How the System Annunciates Supervisories

When a supervisory condition is detected, the system causes the **SUPERVISORY** LED and one of the yellow **Zone TROUBLE** LEDs on the front panel to flash and the system's internal audible to sound.

To Acknowledge Supervisories

1. Unlock and open the door.
2. Press **ACK** to acknowledge (Block Acknowledge) **all** supervisory and other conditions. The system **SUPERVISORY** and the **Zone TROUBLE** LEDs on the front panel stop flashing and remain on and the system's internal audible silences.

To Reset

Press **RESET**. (The system will not reset until all alarms, supervisories, and troubles are acknowledged and all conditions are returned to normal.)

Responding to a Trouble Condition

How the System Annunciates Troubles

When a trouble is detected, the system causes the **TROUBLE** LED and the appropriate yellow **Zone TROUBLE** LEDs on the front panel to flash and the system's internal audible to sound. Troubles will clear prior to Acknowledge if the condition which caused the trouble returns to normal.

Note: Exceptions are Class A zone troubles which always latch.

System troubles are also annunciated by the appropriate trouble code in the 7-segment

display. If an alarm occurs after the trouble is annunciated, the 7-segment display will clear.

To Acknowledge Troubles

1. Unlock and open the door.
2. Press **ACK** to acknowledge (Block Acknowledge) **all** troubles and other conditions. The system **TROUBLE** LED and the **Zone TROUBLE** LEDs on the front panel stop flashing and remain on. The system's internal audible silences.

To Reset

Press **RESET**. (The system will not reset until all alarms, supervisories, and troubles are acknowledged and all conditions are returned to normal.)

System Features

In addition to the standard modes of operation for reporting system conditions, the LW-401 has user-programmable features that are described below. Each topic identifies the Program Level used to select these features. Refer to the Programming section of this manual for instructions on how to activate these features in your LW-401 System.

Initiating Device Circuit (Zone) Types (Program Level 3)

The LW-401 has the following 4 zone types.

- General Alarm
- Alarm Verified Zones
- Supervisory Zones
- Generic Zones

General Alarm is the default setting for all zones. Alarm Verified Zone and Generic

Zone operation are described below.

- Shorting-type input devices and smoke detectors are compatible with all zone types.
- Manual fire alarm stations and smoke detectors can be mixed on zones where local codes allow.
- On verified zones, the manual station reports alarms when activated, without delay.

Alarm Verification

The Alarm Verification Feature provides the LW-401 with a way to verify an alarm from area-type smoke detectors. This feature can be used to reduce incidences of false alarms.

A detector supervised with Alarm Verification is turned off by the System immediately after it reaches an alarm threshold. The trouble LED for that detector's zone turns on. The detector is verified for a length of time which must not exceed 60 seconds. After power is restored to the device, and for the next 60 seconds, if the detector once again reaches the alarm threshold the system will report an alarm condition. If after 60 seconds the detector has not alarmed, any detector which again reaches the alarm threshold will restart the verification cycle. See Figure 7, page 12, for a graphic illustration of the Alarm Verification Time cycle.

CAUTION:

Use only detectors which are subjected to air velocities of less than 100 feet per minute with Alarm Verification. Under dynamic air velocity conditions, smoke may be swept from a smoke detector after the initial alarm. That may cause a long delay before verification. **Do not select Alarm Verification for such applications.**

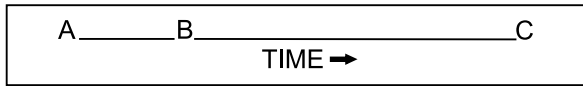

- A → = Time at which the System initially recognizes an alarm from a smoke detector.
- A → B = Retard/Reset Time
The time during which the System ignores the alarm data. System default is 15 seconds plus 6 seconds for LW-401 delay.
- B → C = The 60 seconds during which the System alarms if the device is returning alarm data.

Figure 7
Line Graph of Alarm Verification

Alarm Verification in the LW-401 is applied globally to all selected zones. Therefore, when a detector reaches its alarm threshold and begins the Alarm Verification Time cycle, any detector on any alarm verified zone will react to smoke conditions as if its own Alarm Verification Cycle had begun with the first detector.

Generic Zone

The generic zone is activated (or alarmed) by the output from another control panel. This output should be made with a contact device connected across the Generic zone. When activated, it causes the notification appliance circuits to sound and the appropriate initiating Zone LED to light. When the input is deactivated, the NACs will silence. The System alarm contacts **do not** change state.

Notification Appliance Circuit (NAC or Bell Circuit) Type (Program Level 4)

The LW-401 has two Notification Appliance Circuits, each circuit is rated at 1.5 amps.

The Notification Appliance Circuits can each be programmed for one of the following four code choices:

1. Steady NAC
2. Temporal Code

3. March Time Code
4. Simple Zone Code

A steady tone is the default choice for each circuit. A nonsilenceable NAC has a steady tone. Temporal Code is as defined by NFPA 72. (Simple Zone Code is explained below.)

Please note that while it is possible to program the two NACs with different, non-steady codes, it is not permitted by any authority. Use only one nonsteady code in your LW-401 system.

When distributing power in the system, remember that there are 3 amps available between the two NACs and the auxiliary output. Do not exceed 3 amps total current draw from the system.

Simple Zone Code

Notification Appliance Circuits programmed for simple zone code follow a pre-programmed code pattern. Devices are turned on and off once for Zone 1 alarms, twice for Zone 2 alarms, three times for Zone 3 alarms, etc. The first alarm's code is repeated for the number of rounds programmed in the system, then the next alarm is reported. The minimum allowable number of rounds is three.

When all zones in alarm complete their specified number of rounds in turn, the entire sequence begins again with the first zone in alarm. This sequence is repeated until the system is silenced or reset.

The system operator cannot silence the appliances, or reset the system, until the programmed number of rounds of code have been completed for each alarm. After silencing the appliances, the system reports a new alarm via its particular code, followed by a resound of all previously silenced alarms.

Set Output Control Matrix (Program Level 5)

The LWZE-4A Zone/Output Expander module has four output relays and four open collector outputs. The LWZR-8 Relay module has eight output relays. Initiating Device Circuits can be mapped to these outputs. Any number of zones can be mapped to any output. The first zone in alarm will turn the output on. Also, any zone can be mapped to any number of outputs. When the zone alarms, all mapped outputs will turn on.

The outputs on the LWZE-4A and the LWZR-8 are linked. The outputs are numbered 1 through 8. If a zone is mapped to an output, for example output number 1, the first output on the LWZE-4A **and** LWZR-8 will turn on if both modules are in use.

Bypass Zones and Outputs (Program Levels 1 and 2)

The LW-401 can bypass both Initiating Device Circuits and relays or open collector outputs on the LWZE-4A Zone/Output Expander module and the LWZR-8 Relay module.

- When a circuit is bypassed, the system reports a trouble condition and the Bypass LED will be on.
- When a zone is bypassed, the zone trouble LED will also be on.
- When an output is bypassed, and both the LWZE-4A and the LWZR-8 are in use, the respective output on both cards will be bypassed.

Set System Timing (Program Level 6)

The LW-401 has the following four timing functions:

1. Verification Retard/Reset Timer
2. NAC Inhibit Timer
3. NAC Cutoff Timer
4. Simplified Zone Code Rounds

The Alarm Verification Retard/Reset time establishes the delay time required to provide an alarm verification cycle as determined by the system owner or the local authority. (Complete instructions for the proper selection of this timer follow.)

The NAC Inhibit and Cutoff Timers provide automatic control of evacuation signals.

- The inhibit timer prevents any user from silencing the notification appliances before the selected time expires.
- The cutoff timer automatically turns off all notification appliances after the selected time expires.

Each timer has eight separate selections. When the cutoff timer is set at *No Cutoff* (0 minutes), there is no automatic cutoff and the appliances are energized until silenced or reset.

The last timing function sets the number of rounds of code for those systems using Simple Zone Coding. (Please see the above discussion of NAC types for a full explanation of Simple Zone Coding.) The minimum number of rounds is 3 and the maximum programmable number of rounds is 8.

Alarm Verification Retard/Reset Timer Selection (Program Level 6-1)

The selection of the Alarm Verification feature results in a delay of the system alarm signal to the affected circuits. The total allowable delay is 60 seconds. This delay, the Alarm Verification time, is the sum of a built-in 6 second system delay and the programmed Retard/Reset time. The Retard/Reset time can be set between 15 and 50 seconds, with 15 seconds being the programmed default. (See the definition of zone types above for a further definition of the Alarm Verification Time cycle.)

1. To select the proper Retard/Reset time, begin with the Alarm Verification time required by the system owner or local authority.
2. Subtract the built-in 6 second system delay. Make sure that the result is equal to, or greater than the Detector Start-up Delay from the Table below. If not, the Alarm Verification Time must be lengthened, or a new detector must be selected for the installation.
3. Select the Retard/Reset time from the programming instructions on page 18 which is closest to your result.

Example:

- | | |
|---|------------|
| 1. Alarm Verification Time required by building owner = | 30 seconds |
| 2. Subtract the built-in, 6 second system delay | -6 seconds |
| 3. Result = | 24 seconds |

Select a Retard/Reset Time of 25 seconds from the table on page 18 of the programming instructions.

NOTE: All detectors in the table below, except the 8854/8843, can be used for this application. The 8854/8843 Delay Startup is longer than the Retard/Reset time and therefore would cause the Alarm Verification time to exceed 30 seconds.

Detector	Delay Startup (Seconds)
8900/8901	5
8902/8903	5
8904/8905	5
8854/8843	50

Set System Password (Program Level 7)

The System Password consists of four digits using the four system keys: ACK, RESET, DRILL, SILENCE. The password can be any 4-digit sequence of these keys.

Set AC Fail Signal Delay (Program Level 8)

Underwriters Laboratories, Inc. requires all fire protection systems which communicate to a Central Station to delay the transmission of AC Fail Trouble Signals by a predetermined length of time. The system default is a 6 hour delay. The other option, no delay, is used when the system does not report to a Central Station.

Enable System Option Cards (Program Level 9)

The LW-401 system has the capacity to support the following option cards:

- Either the LWZR-8 Relay module or the LWCT-1 Municipal Tie module
plus
- Either the LWZE-4A or the LWZE-8A Zone/Output Expander module
plus
- 1 or 2 Model LWRA-8B/W Remote Annunciators

The optional modules must be enabled in the LW-401 program or they will not function.

One Person System Test (Test Level 1)

This feature allows one person to test the system by disabling it, activating initiating devices, and listening for the building audibles to sound. After the notification appliances sound, the system will reset and wait for the next device to be activated.

The system can also be tested without the notification appliances. A second person must watch the system display for indication of activated zones. If the system is left inactive during the test, the system will reset to its normal operating mode after 20 minutes.

NOTE: Supervisory zones will appear as alarm zones during this test and the zone alarm LED will turn on.

Last Event Record (Test Level 4)

This feature records the zone in which the last event occurred in each of four categories: Alarms, Troubles, Verified Alarms, and Supervisories. This can be used for troubleshooting one-time reports of events.

Program Mode

The program mode allows the user to change the configuration of the LW-401 system. The program mode has **nine** levels. Each level allows the user to configure a different function within the LW-401.

When the program mode is enabled, the current programming levels and sublevels display in turn on the seven segment display. The order of the display is as follows:

1. the program level is displayed first
2. then a hyphen (-) is displayed
3. then the sublevel is displayed
4. then the display is blank.

The entire sequence then repeats.

In the programming mode, the four function keys operate differently than they do in the normal mode. Their functions are as follows:

The Acknowledge key toggles between the Test mode, the Program mode, and the Leave mode. The seven segment display shows **t**, **P**, and **L**, respectively, to indicate these modes.

The Reset key is used to select program levels and options inside the programming levels.

The Drill key selects options and toggles options on and off.

The Silence key selects different sublevels. Pressing silence when the seven segment display shows **L** exits the user from the program/test mode.

PROGRAM LEVEL DESCRIPTIONS

Level 1: Bypass or enable the LWZE-4A or LWZE-8A Zone Expander card.

Level 2: Bypass or enable the Relay and/or the Open Collector Outputs on the optional LWZE-4A, or LWZE-8A and LWZR-8 cards.

Level 3: Allows configuration of the Initiating Zone Circuits to any one of the following types: **Initiating, Verified Initiating, Supervisory,** and **Generic Input.**

Level 4: Allows configuration of the Notification Appliance Circuits to Non-Silenceable and any one of the following types: **Steady, Temporal, March Time,** and **Simplified Zone Code.**

Level 5: Allows programming of the outputs on the optional LWZE-4A or LWZE-8A Zone/Output Expander card and the LWZR-8 Relay card to follow Alarms on the Initiating Zone Circuits.

Level 6: Allows programming of timer and counter values:

- the Verification Timer between 15 and 50 seconds.
- the Inhibit and Cutoff Timers of the Notification Appliance Circuits.
- the Round Count ranging from 3 to 8 for Simplified Zone Coding.

Level 7: Allows programming of the 4-digit Password.

Level 8: Allows programming of the AC Fail Trouble Signal Delay.

Level 9: Enable/Disable the LWZR-8; LWRA-8B/W, Addresses 1 and 2; LWCT-1; and LWZE-4A/LWZE-8A.

ENABLING THE PROGRAM MODE

Enter Password

1. Press the **RESET** key and hold it down while simultaneously pressing the **DRILL** key. The **System TROUBLE** LED turns on steady and the letter **E** flashes on the seven segment display.
2. Enter the password by pressing the appropriate keys (**ACK = 1, RESET = 2, DRILL = 3, SILENCE = 4**); then press the **SILENCE** key.

For example, the default password is 1111. To enter the default password, press the **ACK** key four times and then press the **SILENCE** key.

The seven segment display either displays **F** to indicate an incorrect password, or **A** to indicate the password is accepted. If the letter **F** appears, repeat steps 1 and 2; if the letter **A** appears, continue on.

Reading the LW-401 Display

As the system is programmed, the 7-segment display shows the current program level and sublevel. When a program level is selected, the program level number is shown in the 7-segment display. When the sublevel is selected, the 7-segment display shows the program number followed by a hyphen, then by the sublevel number.

The red zone LEDs are used to indicate which programmed options have been selected. The zone LEDs correspond to the charts in the following programming and testing instructions for each feature. The yellow zone LED acts as a pointer when changing the current programming.

To Select Program Mode

Press the **ACK** key once. The **PROGRAM/TEST** LED flashes and the seven segment display shows the letter **P**.

To Exit Program Mode

The user can exit the Program mode at any time by pressing the **ACK** key until the **Program/Test** status LED turns off and the letter **L** appears in the seven segment display. Then press the **SILENCE** key to save the system Configuration (only in the Program Mode) and exit the Program/Test Mode.

Program Level 1 - Bypass Zones

1. Press the **Reset** key once to select Program Level 1.
2. Press the **Silence** key to select the Zone to be bypassed.
Example: 1-1 bypasses or enables Zone 1.
3. The red zone LED for the selected zone will be on if the zone is enabled and off if bypassed.
4. Press the **Drill** Key to change the state of the zone.
5. Press the **Silence** key to select another Zone to be bypassed and return to Step 3.
6. Press the **ACK** key when done.

Program Level 2 - Bypass Outputs

1. Press the **Reset** key twice to select Program Level 2.
2. Press the **Silence** key to select the Output to be bypassed.
Example: 2-1 bypasses or enables Output Relay 1.

The Outputs on each card are organized as indicated in the following table:

	LWZE-4A	LWZR-8
Output 1 =	Relay 1	Relay 1
Output 2 =	Relay 2	Relay 2
Output 3 =	Relay 3	Relay 3
Output 4 =	Relay 4	Relay 4
Output 5 =	OC 1	Relay 5
Output 6 =	OC 2	Relay 6
Output 7 =	OC 3	Relay 7
Output 8 =	OC 4	Relay 8

Note: OC = Open Collector

3. The red zone LED for the selected Output will be on if the Output is enabled and off if bypassed.
4. Press the **Drill** key to change the state of the Output.
5. Press the **Silence** key to select another Output to be bypassed and return to Step 3.
6. Press the **ACK** key when done.

Program Level 3 - Set Zone Types

1. Press the **Reset** key 3 times to select Program Level 3.
2. Press the **Silence** key to select the Zone to be programmed.
Example: 3-1 programs the Zone Type for Zone 1.
3. The selected Zone Type is shown by the red zone LED indicated in the following table:

Zone 1 LED	=	Initiating Zone Type
Zone 2 LED	=	Verified Alarm Zone Type
Zone 3 LED	=	Supervisory Zone Type
Zone 4 LED	=	Generic Zone Type

4. Press the **Reset** key to advance the pointer (yellow zone LED) to the desired Zone Type.
5. Press the **Drill** key to activate the desired Zone Type.
6. Press the **Silence** key to select another Zone to be programmed and return to Step 3.
7. Press the **ACK** key when done.

Program Level 4 - Set NAC Types

1. Press the **Reset** key 4 times to select Program Level 4.
2. Press the **Silence** key to select the NAC to be programmed.
Example: 4-1 programs the NAC type for the first Bell Circuit.

3. The selected NAC type is shown by the red zone LED indicated in the following table:

Zone 1 LED	=	Steady NAC
Zone 2 LED	=	Temporal Code
Zone 3 LED	=	March Time Code
Zone 4 LED	=	Simple Zone Code
Zone 5 LED	=	Non-Silenceable Output

4. Press the **Reset** key to advance the pointer (yellow zone LED) to the desired NAC type.
5. Press the **Drill** key to activate the desired NAC type.
6. Press the **Silence** key to select the other NAC to be programmed and return to Step 3.
7. Press the **ACK** key when done.

Program Level 5 - Output Control Matrix

1. Press the **Reset** key 5 times to select Program Level 5.
2. Press the **Silence** key to select the Zone to be programmed.
Ex: 5-1 allows mapping Zone 1 to Outputs.
3. The selected Zone Map is shown by the red zone LEDs indicated in the following table:

Zone 1 LED	=	Zone Mapped to Output 1
Zone 2 LED	=	Zone Mapped to Output 2
Zone 3 LED	=	Zone Mapped to Output 3
Zone 4 LED	=	Zone Mapped to Output 4
Zone 5 LED	=	Zone Mapped to Output 5
Zone 6 LED	=	Zone Mapped to Output 6
Zone 7 LED	=	Zone Mapped to Output 7
Zone 8 LED	=	Zone Mapped to Output 8

4. Press the **Reset** key to advance the pointer (yellow zone LED) to the desired Output.

5. Press the **Drill** key to map the selected Zone to the desired Output.
6. Press the **Silence** key to select another Zone to be programmed and return to Step 3.
7. Press the **ACK** key when done.

Program Level 6 - Set System Timing

1. Press the **Reset** key 6 times to select Program Level 6.
2. Press the **Silence** key to select one of the four timing functions to be programmed as indicated in the following table:

Example: 6-1 programs the Alarm Verification Retard/Reset Timer.

Level	Feature
6-1	Verification Retard/Reset Timer
6-2	NAC Inhibit Timer
6-3	NAC Cutoff Timer
6-4	Simplified Zone Code Rounds

Level 6-1 - Set Verification Retard/Reset Timer

1. The selected Retard/Reset Time is shown by the red zone LEDs according to the following table:

Zone 1 LED	=	15 seconds
Zone 2 LED	=	20 seconds
Zone 3 LED	=	25 seconds
Zone 4 LED	=	30 seconds
Zone 5 LED	=	40 seconds
Zone 6 LED	=	50 seconds
Zone 7 LED	=	50 seconds
Zone 8 LED	=	50 seconds

2. Press the **Reset** key to advance the pointer (yellow zone LED) to the desired time.
3. Press the **Drill** key to activate the desired time.
4. Press the **ACK** key when done.

Level 6-2 - Set NAC Inhibit Timer

1. The selected Inhibit Time is shown by the red zone LEDs as indicated in the following table:

Zone 1 LED	=	0 minutes
Zone 2 LED	=	6 seconds
Zone 3 LED	=	30 seconds
Zone 4 LED	=	1 minutes
Zone 5 LED	=	90 seconds
Zone 6 LED	=	2 minutes
Zone 7 LED	=	3 minutes
Zone 8 LED	=	5 minutes

2. Press the **Reset** key to advance the pointer (yellow zone LED) to the desired time.
3. Press the **Drill** key to activate the desired time.
4. Press the **ACK** key when done.

Level 6-3 - Set NAC Cutoff Timer

1. The selected Cutoff Time is shown by the red zone LEDs as indicated in the following table:

Zone 1 LED	=	No Cutoff
Zone 2 LED	=	1 minutes
Zone 3 LED	=	2 minutes
Zone 4 LED	=	5 minutes
Zone 5 LED	=	10 minutes
Zone 6 LED	=	15 minutes
Zone 7 LED	=	20 minutes
Zone 8 LED	=	25 minutes

2. Press the **Reset** key to advance the pointer (yellow zone LED) to the desired time.
3. Press the **Drill** key to activate the desired time.
4. Press the **ACK** key when done.

Level 6-4 - Set Simplified Zone Code Rounds

1. The selected number of rounds is shown by the red zone LEDs as indicated in the following table:

Zone 3 LED	=	3 rounds
Zone 4 LED	=	4 rounds
Zone 5 LED	=	5 rounds
Zone 6 LED	=	6 rounds
Zone 7 LED	=	7 rounds
Zone 8 LED	=	8 rounds

2. Press the **Reset** key to advance the pointer (yellow zone LED) to the desired time.
3. Press the **Drill** key to activate the desired time.
4. Press the **ACK** key when done.

Program Level 7 - Set System Password

1. Press the **Reset** key 7 times to select Program Level 7.
2. Press the **Silence** key to select the Password digit to be programmed. Example: 7-1 programs the first digit of your password.
3. The selected digit choice is shown by the red zone LED as indicated in the following table:

Zone 1 LED	=	ACK (1)
Zone 2 LED	=	RESET (2)
Zone 3 LED	=	DRILL (3)
Zone 4 LED	=	SILENCE (4)

4. Press the **Reset** key to advance the pointer (yellow zone LED) to the desired digit choice.
5. Press the **Drill** key to activate the desired digit choice.

6. Press the **Silence** key to select another digit to be programmed and return to Step 3.
7. Press the **ACK** key when done.

Program Level 8 - Set the AC Fail Signal Delay

1. Press the **Reset** key 8 times to select Program Level 8.
2. Press the **Silence** key to select this programming function. There is no other function to be selected.
Note: 8-1 programs the AC Fail Signal Delay.
3. A six-hour delay is activated when the red zone LED for zone 1 is on. If the LED is off, there is no delay.
4. Press the **Drill** key to activate or deactivate the delay.
5. Press the **ACK** key when done.

Program Level 9 - Enable System Option Cards

1. Press the **Reset** key 9 times to select Program Level 9.
2. Press the **Silence** key to select this programming function. There is no other function to be selected.
Note: 9-1 enables the System Option Cards.
3. The selected Option Cards are shown by the red zone LED as indicated in the following table:

Zone 1 LED	=	LWZR-8 Enabled
Zone 2 LED	=	LWRA-8B/W, Addr 1 Enabled
Zone 3 LED	=	LWRA-8B/W, Addr 2 Enabled
Zone 4 LED	=	LWCT-1 Enabled
Zone 5 LED	=	Zone Expansion Enabled

4. Press the **Reset** key to advance the pointer (yellow zone LED) to the desired Option Card.
 5. Press the **Drill** key to activate the desired Option Card.
 6. Press the **ACK** key when done.
- **Level 5:** Performs Local Display and Remote (LWRA-8B/W) Lamp test.
 - **Level 6:** Clears the panel's history events (Alarm, Trouble, and Supervisory).

Test Mode

The test mode allows the user to test that the LW-401 is operating correctly. There are six levels to the test mode. Each level tests different functions within the LW-401.

Reading the LW-401 Display

As the system is tested, the 7-segment display shows the current test level and sublevel. When a test level is selected, the test level number is shown in the 7-segment display. When the sublevel is selected, the 7-segment display shows the test number followed by a hyphen, then by the sublevel number.

TEST LEVEL DESCRIPTIONS

- **Level 1:** Enables the One Person System Test Function.
- **Level 2:** Tests the Main board Alarm and Trouble relays and NAC relays.
- **Level 3:** Tests the Optional Module Relays and Open Collector Output Drivers.
- **Level 4:** Displays the Alarm, Trouble, and Supervisory history on the Initiating Device Circuit Zone status LEDs.

ENABLING THE TEST MODE

Enter Password

1. Press the **RESET** key and hold it down while simultaneously pressing the **DRILL** key. The System **TROUBLE** status LED lights steady, and the letter **E** flashes on the seven segment display.
2. Enter the password by pressing the appropriate keys (**ACK = 1, RESET = 2, DRILL = 3, SILENCE = 4**); then press the **SILENCE** key. The seven segment display either displays **F** to indicate an incorrect password, or **A** to indicate the password is accepted. If the letter **F** appears, repeat steps 1 and 2; if the letter **A** appears, continue on.

To Select Test Mode

Press the **ACK** key twice. The **PROGRAM/TEST** status LED on the front panel lights steady and the seven segment display shows the letter **t**.

To Exit Test Mode

The user can exit the Test mode at any time by pressing the **ACK** key until the **Program/Test** status LED turns off and the letter **L** appears in the seven segment display. Then press the **SILENCE** key to exit the Program/Test Mode.

Test Level 1—One Person System Test

Important

Inform the person in charge of the LW-401 fire alarm system that a One Person Test is to be performed and that part or all of the fire detection system will be disabled. It is also advisable (or may be required) to notify the fire department of the test.

The One Person Test feature allows the installer to test the system in the following two ways.

- When a device is alarmed, the system notification appliances sound and the appropriate IDC alarm LED lights for 2 seconds.
- When a device is alarmed, the sounding of the appliances is eliminated—only the system display annunciates.

1. Press the **Reset** key once to select Test Level 1.
2. Press the **Silence** key once or twice to select the type of test you wish to perform.

Example: 1-1 enables test with notification appliances;
1-2 enables test without appliances.

Test Level 2 - Test System Relays

1. Press the **Reset** key twice to select Test Level 2.
2. Press the **Silence** key to select one of the four relays to be tested as indicated in the following table:

Example: 2-1 tests the System Alarm Relay.

Level	Feature
2-1	Test System Alarm Relay
2-2	Test NAC 1 Relay
2-3	Test System Trouble Relay
2-4	Test NAC 2 Relay

3. Press the **Drill** key to change the state of the selected relay. Please note that testing the NAC relays will activate the appliances on that circuit.
4. Press the **ACK** key when done.

Test Level 3 - Test Optional Outputs

1. Press the **Reset** Key 3 times to select Test Level 3.
2. Press the **Silence** Key to select one of the eight outputs to be tested as indicated in the following table:
Example: 3-1 tests Relay Output 1.

Level	Feature
3-1	Test Output 1
3-2	Test Output 2
3-3	Test Output 3
3-4	Test Output 4
3-5	Test Output 5
3-6	Test Output 6
3-7	Test Output 7
3-8	Test Output 8

The Outputs on each card are organized according to the following table:

LWZE-4A	LWZR-8
Output 1 = Relay 1	Relay 1
Output 2 = Relay 2	Relay 2
Output 3 = Relay 3	Relay 3
Output 4 = Relay 4	Relay 4
Output 5 = OC 1	Relay 5
Output 6 = OC 2	Relay 6
Output 7 = OC 3	Relay 7
Output 8 = OC 4	Relay 8

Note: OC = Open Collector

3. Press the **Drill** key to change the state of the selected output.
4. Press the **ACK** key when done.

Test Level 4 - Last Event Record

1. Press the **Reset** key 4 times to select Test Level 4.
2. Press the **Silence** key to select the event to be reviewed per the following table:
Example: 4-1 reviews the last zone in alarm.

Level	Feature
4-1	Review Last Alarm
4-2	Review Last Zone Trouble
4-3	Review Last Verification
4-4	Review Last Supervisory

3. The Zone Alarm LED for the last zone in alarm will be on. Similarly, the Zone Trouble LED will be on for the last zones in supervisory and trouble conditions.
4. Press the **ACK** key when done.

Test Level 5 - Lamp Test

1. Press the **Reset** key 5 times to select Test Level 5.
2. Press the **Silence** key to select the lamps to be tested as indicated in the following table:
Example: 5-1 tests Local Display.

Level	Feature
5-1	Test the Local Display
5-2	Test Remote Annunciators

3. Press and hold the **Drill** key to turn the lamps on.
4. Press the **ACK** key when done.

Test Level 6 - Clear the Last Event Record

1. Press the **Reset** key 6 times to select Test Level 6.
2. Press the **Silence** key to select this function. There is no other function to be selected.
3. Press the **Drill** key to clear the event record.
4. Press the **ACK** key when done.

**TABLE 1
PROGRAM MODE LEVELS**

Level	Sublevel	Description
1	1	Enable/Bypass Initiating Device Circuit Zone 1
	2	Enable/Bypass Initiating Device Circuit Zone 2
	3	Enable/Bypass Initiating Device Circuit Zone 3
	4	Enable/Bypass Initiating Device Circuit Zone 4
	5	Enable/Bypass Initiating Device Circuit Zone 5
	6	Enable/Bypass Initiating Device Circuit Zone 6
	7	Enable/Bypass Initiating Device Circuit Zone 7
	8	Enable/Bypass Initiating Device Circuit Zone 8
2	1	Enable/Bypass Optional LWZE-4A, LWZE-8A or LWZR-8 Output Relay 1
	2	Enable/Bypass Optional LWZE-4A, LWZE-8A or LWZR-8 Output Relay 2
	3	Enable/Bypass Optional LWZE-4A, LWZE-8A or LWZR-8 Output Relay 3
	4	Enable/Bypass Optional LWZE-4A, LWZE-8A or LWZR-8 Output Relay 4
	5	Enable/Bypass Optional LWZE-4A Open Collector Output 1 (or Relay 5 - LWZE-8A or LWZR-8 only)
	6	Enable/Bypass Optional LWZE-4A Open Collector Output 2 (or Relay 6 - LWZE-8A or LWZR-8 only)
	7	Enable/Bypass Optional LWZE-4A Open Collector Output 3 (or Relay 7 - LWZE-8A or LWZR-8 only)
	8	Enable/Bypass Optional LWZE-4A Open Collector Output 4 (or Relay 8 - LWZE-8A or LWZR-8 only)
3	1	Initiating Device Circuit Type Zone 1
	2	Initiating Device Circuit Type Zone 2
	3	Initiating Device Circuit Type Zone 3
	4	Initiating Device Circuit Type Zone 4
	5	Initiating Device Circuit Type Zone 5
	6	Initiating Device Circuit Type Zone 6
	7	Initiating Device Circuit Type Zone 7
	8	Initiating Device Circuit Type Zone 8
4	1	Programs Signaling Type for Notification Appliance Circuit 1
	2	Programs Signaling Type for Notification Appliance Circuit 2
5	1	Programs Open Collector/Relays to Follow Initiating Zone Circuit 1
	2	Programs Open Collector/Relays to Follow Initiating Zone Circuit 2
	3	Programs Open Collector/Relays to Follow Initiating Zone Circuit 3
	4	Programs Open Collector/Relays to Follow Initiating Zone Circuit 4
	5	Programs Open Collector/Relays to Follow Initiating Zone Circuit 5
	6	Programs Open Collector/Relays to Follow Initiating Zone Circuit 6
	7	Programs Open Collector/Relays to Follow Initiating Zone Circuit 7
	8	Programs Open Collector/Relays to Follow Initiating Zone Circuit 8
6	1	Programs the Alarm Verification Timer
	2	Programs the Notification Appliance Circuit Inhibit Timer
	3	Programs the Notification Appliance Circuit Cutoff Timer
	4	Programs the Zone Code Round Count (3 to 8 count range)
7	1	Programs Password Digit 1
	2	Programs Password Digit 2
	3	Programs Password Digit 3
	4	Programs Password Digit 4
8	1	Select AC Fail Signal Delay
9	1	Enable/Disable LWZR-8; Enable/Disable LWRA-8B/W; Enable/Disable LWCT-1; Enable/Disable LWZE-4A/LWZE-8A

**TABLE 2
TEST MODE LEVELS**

Level	Sublevel	Description
1	1	One Person System Test with Notification Appliance Circuits Activated
	2	One Person System Test with Notification Appliance Circuits Silenced
2	1	Test Main Board Alarm Relay
	2	Test NAC 1 Relay
	3	Test Main Board Trouble Relay
	4	Test NAC 2 Relay
3	1	Test Optional LWZE-4A, LWZE-8A or LWZR-8 Output Relay 1
	2	Test Optional LWZE-4A, LWZE-8A or LWZR-8 Output Relay 2
	3	Test Optional LWZE-4A, LWZE-8A or LWZR-8 Output Relay 3
	4	Test Optional LWZE-4A, LWZE-8A or LWZR-8 Output Relay 4
	5	Test Optional LWZE-4A Open Collector Output 1 (or Relay 5 - LWZE-8A or LWZR-8 only)
	6	Test Optional LWZE-4A Open Collector Output 2 (or Relay 6 - LWZE-8A or LWZR-8 only)
	7	Test Optional LWZE-4A Open Collector Output 3 (or Relay 7 - LWZE-8A or LWZR-8 only)
	8	Test Optional LWZE-4A Open Collector Output 4 (or Relay 8 - LWZE-8A or LWZR-8 only)
4	1	Display Last Alarm Event
	2	Display Last Trouble Event
	3	Display Last Verification Event
	4	Display Last Supervisory Event
5	1	Local Display Lamp Test
	2	Remote Display Lamp Test
6	1	Clear Event Record

4

CHECKOUT PROCEDURE

Prior to installing devices on bases and applying power to the LW-401 system, follow the **Field Wiring Checkout Procedure** (Refer to Table 5, page 27).

On completion of installation, the system should be thoroughly tested. Check supervision functions and the functional operation of each external circuit, as well as the basic system control panel functions.

Maintenance

PERIODIC INSPECTION AND TESTING

To insure proper and reliable operation, inspect and test the system to the latest edition of NFPA 72 *Signaling Systems*.

SERVICING

If troubleshooting and servicing guidance is needed, contact your local Cerberus Pyrotechnics Authorized Service Representative.

**TABLE 3
SYSTEM FAULT TROUBLESHOOTING**

Fault Code Display	Trouble	Possible Cause
1	AC Power Fail	Check AC Power Source AC Circuit Wiring Open Open F1 AC Fuse Brownout
2	Notification Appliance Circuit 1 Fault	Open Wire Missing End of Line Resistor Shorted Wire NAC Device Wired Backward NAC Device Not Polarized
3	Notification Appliance Circuit 2 Fault	Open Wire Missing End of Line Resistor Shorted Wire NAC Device Wired Backward NAC Device Not Polarized
4	Ground Fault	Less than 1 megohm from Earth Ground to Circuit
5	Municipal Tie Fault	Municipal Tie is Tripped Municipal Tie is Bad
6	Battery Fault	Battery is Missing Open F3 Battery Fuse
7	System Configuration Fault	Reconfigure the LW-401
8	Auxiliary Port Fault	Short on DATA Line LWZR-8 Module Not Present/Not Responding LWRA-8B/W Module Not Present/Not Responding LWCT-1 Module Not Present/Not Responding
9	Output Bypassed	Any Control Output Bypassed
0	Hardware Failure	The LW-401 Main board processor has failed Replace the board.
BLANK	Bells/Strobes Turn on Briefly then Shut off During Test	NAC is Overloaded Check Current Draw of all Devices on the Circuit

**TABLE 4
ELECTRICAL REQUIREMENTS FOR BATTERY CALCULATIONS
AND POWER MANAGEMENT**

	Standby Current	Alarm Current
Main Board Current	0.110A	0.120A
IDC Current (Zones 1-4): Number of IDC Zones _____ _____ x 0.009A (Standby) = _____ A _____ x 0.120A (Alarm) = _____ A	_____ A 0A	0A _____ A
NAC Device Current: _____ NAC 1 _____ NAC 2 _____ Current <= 1.5A per NAC See Note 1	0A 0A	_____ A _____ A
Auxiliary Port Current: LWZE-8 Module _____ Number of Programmed Relays _____ _____ x 0.026A = _____ Current <= 0.5A See Note 1 Standby Current 0.018A Alarm Current 0.018A	_____ A 0A	_____ A _____ A
LWZE-4A Module _____ Number of Programmed Relays _____ _____ x 0.026A = _____ IDC Current (Zones 5-8): Number of IDC Zones _____ _____ x 0.009A (Standby) = _____ A _____ x 0.120A (Alarm) = _____ A Standby Current 0.006A Alarm Current 0.006A	_____ A 0A _____ A 0A	_____ A _____ A _____ A 0A
LWZE-8A Module _____ IDC Current (Zones 5-8): Number of IDC Zones _____ _____ x 0.009A (Standby) = _____ A _____ x 0.120A (Alarm) = _____ A Standby Current 0.006A Alarm Current 0.006A	_____ A _____ A 0A	_____ A 0A _____ A
LWRA-8B/W Module _____ Number of LWRA-8B/W Modules _____ _____ x 0.010A (Standby) = _____ A _____ x 0.042A (Alarm) = _____ A	_____ A 0A	0A _____ A
LWCT-1 Module _____ Standby = _____ Alarm = _____	0.050A 0A	0A 0.345A
Total	_____ A	_____ A
Total Standby Current _____ x Standby Hours (24, 48, or 60) _____ = Standby A-H Current _____ A-H		
Total Alarm Current _____ x A-H Multiplier Factor (5 Min.) 0.083 = Alarm A-H Current _____ A-H		
(Standby A-H Current + Alarm A-H Current) x 1.22 = Minimum A-H Battery Size _____ A-H		

NOTE:

1. In addition to determining the required battery size, consideration must be given to the overall current drawn by the system. The total system current capability is 3.5 amps at 24 volts. The total alarm current must not exceed 3.5 amps for any combination of the basic system plus any additional modules used. When installing additional modules, the current available for the NAC circuits and auxiliary port must be derated to keep the total alarm current below 3.5 amps.

<= means less than or equal to

**TABLE 5
FIELD WIRING CHECKOUT PROCEDURE**

MEASURE RESISTANCE BETWEEN TERMINAL AND TERMINAL		DESIRED RESULTS	PROBABLE CAUSE IF RESULTS DIFFER
<i>Meter connection for Field Wiring Checkout Procedure Steps 1 and 2: Positive lead connected to BL1-1 or BL2-1 and negative lead connected to BL1-2 or BL2-2.</i>			
1. Measure Notification Appliance Circuit Loop Resistance <i>Before making resistance measurements, short the End of Line Resistor (10K ohms).</i>			
BL1-1	BL1-2	<3.0 ohms	Line open
BL2-1	BL2-2	<3.0 ohms	Line too long
2. Measure Notification Appliance Circuit End of Line Resistance <i>Before making resistance measurements, remove the short from the previous step.</i>			
BL1-1	BL1-2	10K ohms	Line shorted; Line open
BL2-1	BL2-2	10K ohms	Wrong End of Line Resistor value NAC Device wired backward NAC Device not polarized
3. Check for Ground Fault			
BL1-1	To all other Main Control module terminals excluding NAC 1	> 1 megohm	Line shorted
BL1-2			
BL2-1	To all other Main Control module terminals excluding NAC 2	> 1 megohm	Line shorted
BL2-2			
<i>Meter connection to Field Wiring Checkout Procedure Steps 4, 5, and 6: Positive lead connected to IDC + and negative lead connected to IDC -. Do not connect initiating devices to the ID loop for resistance measurements in Field Wiring Checkout Procedure Steps 4, 5, and 6.</i>			
4. Measure Initiating Device Circuit Loop Resistance <i>Before making resistance measurements, short the End of Line Resistor (3.9K Ohms).</i>			
IDC1 +	IDC1 -	< 25 ohms	Line open; Line too long
IDC2 +	IDC2 -	< 25 ohms	
IDC3 +	IDC3 -	< 25 ohms	
IDC4 +	IDC4 -	< 25 ohms	
5. Measure Initiating Device Circuit End of Line Resistance <i>Before making resistance measurements, remove the short from the previous step.</i>			
IDC1 +	IDC1 -	3.9K ohms	Line shorted; Line open
IDC2 +	IDC2 -	3.9K ohms	Wrong End of Line Resistor value
IDC3 +	IDC3 -	3.9K ohms	
IDC4 +	IDC4 -	3.9K ohms	
6. Check for Ground Fault			
IDC1 +	To all other Main Control module terminals excluding the IDC -	> 1 megohm	Line shorted
IDC2 +			
IDC3 +			
IDC4 +			
IDC1 -	To all other Main Control module terminals excluding the IDC +	> 1 megohm	Line shorted
IDC2 -			
IDC3 -			
IDC4 -			

**TABLE 6
DEFAULT CONFIGURATIONS**

Level	Sublevel	Description	User	Factory
1	1	Initiating Device Circuit Zone 1	Enabled	Enabled
	2	Initiating Device Circuit Zone 2	Enabled	Enabled
	3	Initiating Device Circuit Zone 3	Enabled	Enabled
	4	Initiating Device Circuit Zone 4	Enabled	Enabled
	5	Initiating Device Circuit Zone 5	Enabled	Enabled
	6	Initiating Device Circuit Zone 6	Enabled	Enabled
	7	Initiating Device Circuit Zone 7	Enabled	Enabled
	8	Initiating Device Circuit Zone 8	Enabled	Enabled
2	1	Optional LWZE-4A Output Relay 1	Enabled	Enabled
	2	Optional LWZE-4A Output Relay 2	Enabled	Enabled
	3	Optional LWZE-4A Output Relay 3	Enabled	Enabled
	4	Optional LWZE-4A Output Relay 4	Enabled	Enabled
	5	Optional LWZE-4A Open Collector Output 1	Enabled	Enabled
	6	Optional LWZE-4A Open Collector Output 2	Enabled	Enabled
	7	Optional LWZE-4A Open Collector Output 3	Enabled	Enabled
	8	Optional LWZE-4A Open Collector Output 4	Enabled	Enabled
3	1	Zone 1	Initiating	Initiating
	2	Zone 2	Initiating	Initiating
	3	Zone 3	Initiating	Initiating
	4	Zone 4	Initiating	Initiating
	5	Zone 5	Initiating	Not used
	6	Zone 6	Initiating	Not used
	7	Zone 7	Initiating	Not used
	8	Zone 8	Initiating	Not used
4	1	Notification Appliance Circuit 1	Steady	Steady
	2	Notification Appliance Circuit 2	Steady	Steady
5	1	Initiating Zone Circuit 1	No control	No control
	2	Initiating Zone Circuit 2	No control	No control
	3	Initiating Zone Circuit 3	No control	No control
	4	Initiating Zone Circuit 4	No control	No control
	5	Initiating Zone Circuit 5	No control	No control
	6	Initiating Zone Circuit 6	No control	No control
	7	Initiating Zone Circuit 7	No control	No control
	8	Initiating Zone Circuit 8	No control	No control
6	1	Retard Reset Timer	15 seconds	15 seconds
	2	Inhibit Timer	0	0
	3	Cutoff Timer	0	0
	4	Zone Code Round Count	3	3
7	1	Password Digit 1	1	1
	2	Password Digit 2	1	1
	3	Password Digit 3	1	1
	4	Password Digit 4	1	1
8	1	Set AC Fail Signal Delay	6 Hours	6 Hours
9	1	Optional LWZR-8; LWRA-8B/W Addr 1 and 2; LWCT-1; LWZE-4A/LWZE-8A	LWZE-4A/LWZE8A Enabled	Disabled

**TABLE 7
PROGRAMMING SHEET**

Level	Sublevel	Description
1	1	Initiating Device Circuit Zone 1 Enabled <input type="checkbox"/> Bypassed <input type="checkbox"/>
	2	Initiating Device Circuit Zone 2 Enabled <input type="checkbox"/> Bypassed <input type="checkbox"/>
	3	Initiating Device Circuit Zone 3 Enabled <input type="checkbox"/> Bypassed <input type="checkbox"/>
	4	Initiating Device Circuit Zone 4 Enabled <input type="checkbox"/> Bypassed <input type="checkbox"/>
	5	Initiating Device Circuit Zone 5 Enabled <input type="checkbox"/> Bypassed <input type="checkbox"/>
	6	Initiating Device Circuit Zone 6 Enabled <input type="checkbox"/> Bypassed <input type="checkbox"/>
	7	Initiating Device Circuit Zone 7 Enabled <input type="checkbox"/> Bypassed <input type="checkbox"/>
	8	Initiating Device Circuit Zone 8 Enabled <input type="checkbox"/> Bypassed <input type="checkbox"/>
2	1	Optional LWZE-4A/LWZE-8A/LWZR-8 Output 1 Enabled <input type="checkbox"/> Bypassed <input type="checkbox"/>
	2	Optional LWZE-4A/LWZE-8A/LWZR-8 Output 2 Enabled <input type="checkbox"/> Bypassed <input type="checkbox"/>
	3	Optional LWZE-4A/LWZE-8A/LWZR-8 Output 3 Enabled <input type="checkbox"/> Bypassed <input type="checkbox"/>
	4	Optional LWZE-4A/LWZE-8A/LWZR-8 Output 4 Enabled <input type="checkbox"/> Bypassed <input type="checkbox"/>
	5	Optional LWZE-4A/LWZE-8A/LWZR-8 Output 5 Enabled <input type="checkbox"/> Bypassed <input type="checkbox"/>
	6	Optional LWZE-4A/LWZE-8A/LWZR-8 Output 6 Enabled <input type="checkbox"/> Bypassed <input type="checkbox"/>
	7	Optional LWZE-4A/LWZE-8A/LWZR-8 Output 7 Enabled <input type="checkbox"/> Bypassed <input type="checkbox"/>
	8	Optional LWZE-4A/LWZE-8A/LWZR-8 Output 8 Enabled <input type="checkbox"/> Bypassed <input type="checkbox"/>
3	1	Zone 1 Initiating <input type="checkbox"/> Verified <input type="checkbox"/> Supervisory <input type="checkbox"/> Generic <input type="checkbox"/>
	2	Zone 2 Initiating <input type="checkbox"/> Verified <input type="checkbox"/> Supervisory <input type="checkbox"/> Generic <input type="checkbox"/>
	3	Zone 3 Initiating <input type="checkbox"/> Verified <input type="checkbox"/> Supervisory <input type="checkbox"/> Generic <input type="checkbox"/>
	4	Zone 4 Initiating <input type="checkbox"/> Verified <input type="checkbox"/> Supervisory <input type="checkbox"/> Generic <input type="checkbox"/>
	5	Zone 5 Initiating <input type="checkbox"/> Verified <input type="checkbox"/> Supervisory <input type="checkbox"/> Generic <input type="checkbox"/>
	6	Zone 6 Initiating <input type="checkbox"/> Verified <input type="checkbox"/> Supervisory <input type="checkbox"/> Generic <input type="checkbox"/>
	7	Zone 7 Initiating <input type="checkbox"/> Verified <input type="checkbox"/> Supervisory <input type="checkbox"/> Generic <input type="checkbox"/>
	8	Zone 8 Initiating <input type="checkbox"/> Verified <input type="checkbox"/> Supervisory <input type="checkbox"/> Generic <input type="checkbox"/>
4	1	NAC 1 Steady <input type="checkbox"/> Temporal <input type="checkbox"/> March <input type="checkbox"/> SZC <input type="checkbox"/> Non-Silenceable <input type="checkbox"/>
	2	NAC 2 Steady <input type="checkbox"/> Temporal <input type="checkbox"/> March <input type="checkbox"/> SZC <input type="checkbox"/> Non-Silenceable <input type="checkbox"/>
5	1	IDC 1 Output 1 <input type="checkbox"/> 2 <input type="checkbox"/> 3 <input type="checkbox"/> 4 <input type="checkbox"/> 5 <input type="checkbox"/> 6 <input type="checkbox"/> 7 <input type="checkbox"/> 8 <input type="checkbox"/>
	2	IDC 2 Output 1 <input type="checkbox"/> 2 <input type="checkbox"/> 3 <input type="checkbox"/> 4 <input type="checkbox"/> 5 <input type="checkbox"/> 6 <input type="checkbox"/> 7 <input type="checkbox"/> 8 <input type="checkbox"/>
	3	IDC 3 Output 1 <input type="checkbox"/> 2 <input type="checkbox"/> 3 <input type="checkbox"/> 4 <input type="checkbox"/> 5 <input type="checkbox"/> 6 <input type="checkbox"/> 7 <input type="checkbox"/> 8 <input type="checkbox"/>
	4	IDC 4 Output 1 <input type="checkbox"/> 2 <input type="checkbox"/> 3 <input type="checkbox"/> 4 <input type="checkbox"/> 5 <input type="checkbox"/> 6 <input type="checkbox"/> 7 <input type="checkbox"/> 8 <input type="checkbox"/>
	5	IDC 5 Output 1 <input type="checkbox"/> 2 <input type="checkbox"/> 3 <input type="checkbox"/> 4 <input type="checkbox"/> 5 <input type="checkbox"/> 6 <input type="checkbox"/> 7 <input type="checkbox"/> 8 <input type="checkbox"/>
	6	IDC 6 Output 1 <input type="checkbox"/> 2 <input type="checkbox"/> 3 <input type="checkbox"/> 4 <input type="checkbox"/> 5 <input type="checkbox"/> 6 <input type="checkbox"/> 7 <input type="checkbox"/> 8 <input type="checkbox"/>
	7	IDC 7 Output 1 <input type="checkbox"/> 2 <input type="checkbox"/> 3 <input type="checkbox"/> 4 <input type="checkbox"/> 5 <input type="checkbox"/> 6 <input type="checkbox"/> 7 <input type="checkbox"/> 8 <input type="checkbox"/>
	8	IDC 8 Output 1 <input type="checkbox"/> 2 <input type="checkbox"/> 3 <input type="checkbox"/> 4 <input type="checkbox"/> 5 <input type="checkbox"/> 6 <input type="checkbox"/> 7 <input type="checkbox"/> 8 <input type="checkbox"/>
6	1	Retard Reset Timer 15 <input type="checkbox"/> 20 <input type="checkbox"/> 25 <input type="checkbox"/> 30 <input type="checkbox"/> 40 <input type="checkbox"/> 50 <input type="checkbox"/> 50 <input type="checkbox"/> 50 <input type="checkbox"/> seconds
	2	Inhibit Timer 0 <input type="checkbox"/> 6 <input type="checkbox"/> 30 <input type="checkbox"/> 60 <input type="checkbox"/> 90 <input type="checkbox"/> 120 <input type="checkbox"/> 180 <input type="checkbox"/> 300 <input type="checkbox"/> seconds
	3	Cutoff Timer 0 <input type="checkbox"/> 1 <input type="checkbox"/> 2 <input type="checkbox"/> 5 <input type="checkbox"/> 10 <input type="checkbox"/> 15 <input type="checkbox"/> 20 <input type="checkbox"/> 25 <input type="checkbox"/> minutes
	4	Zone Code Round Count (3 to 8)=
7	1	Password Digit 1 =
	2	Password Digit 2 =
	3	Password Digit 3 =
	4	Password Digit 4 =
8	1	AC Fail Signal Delay 0 Hours <input type="checkbox"/> 6 Hours <input type="checkbox"/>
9	1	LWZR-8 Enabled <input type="checkbox"/> #1 LWRA-8B/W Enabled <input type="checkbox"/> #2 LWRA-8B/W Enabled <input type="checkbox"/> LWCT-1 Enabled <input type="checkbox"/> LWZE-4A/LWZE-8A Enabled <input type="checkbox"/>

WARNING: This equipment generates, uses, and can radiate radio frequency energy and if not installed and used in accordance with the instructions manual, may cause interference to radio communications. It has been tested and found to comply with the limits for a Class A computing device pursuant to Subpart J of Part 15 of FCC Rules, which are designed to provide reasonable protection against such interference when operated in a commercial environment. Operation of this equipment in a residential area is likely to cause interference in which case the user at his own expense will be required to take whatever measures may be required to correct the interference.

