

FIDS ELEV.
SCALE: 3/4" = 1'-0" A11.00 7

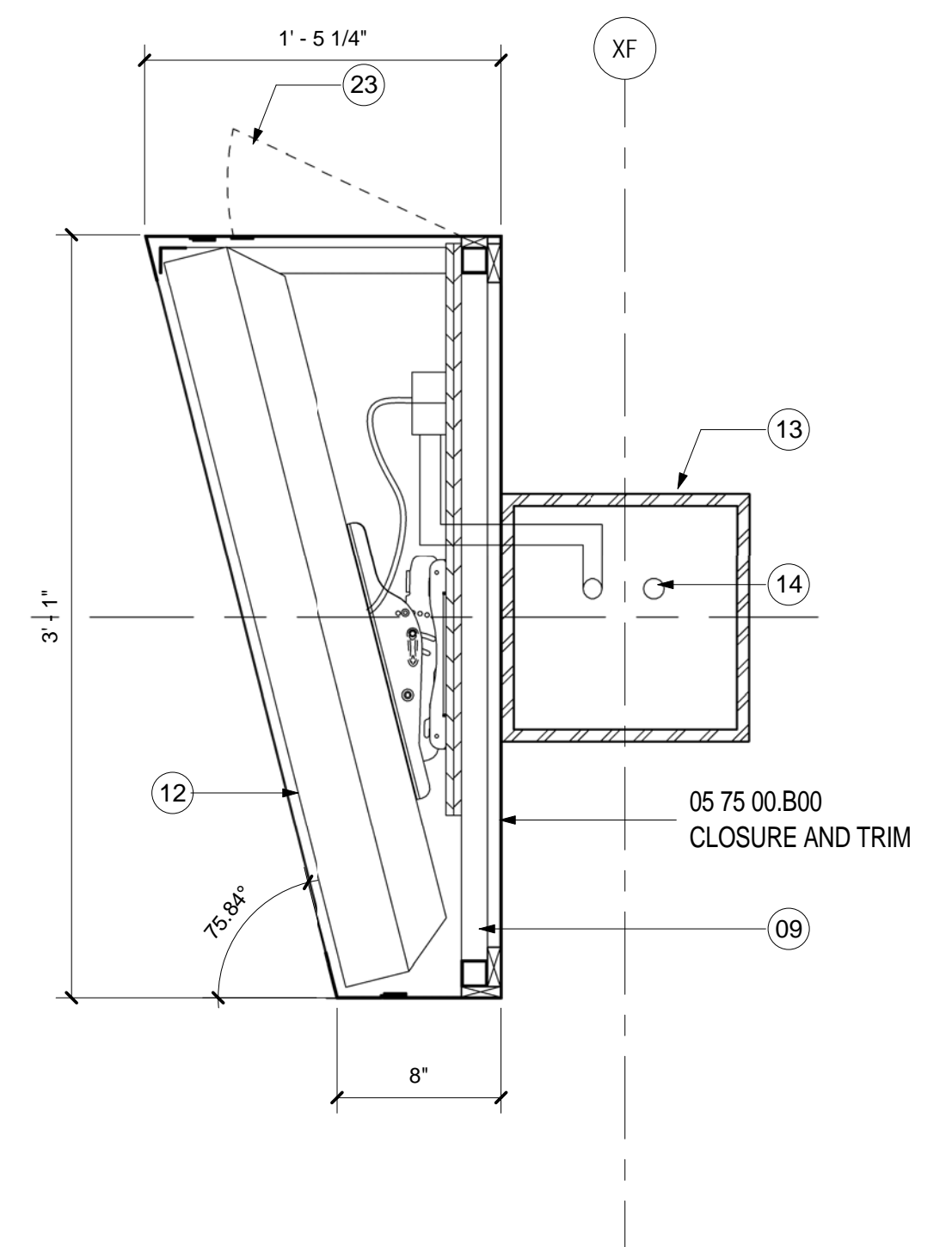

FID SECTION
SCALE: 1 1/2" = 1'-0" A12.92 8

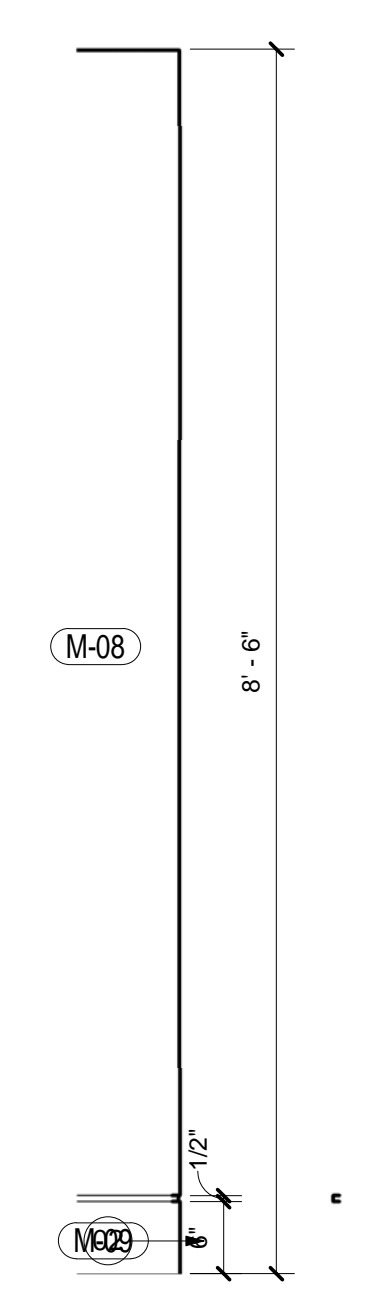

FIDS ELEV.
SCALE: 3/4" = 1'-0" A12.92 5

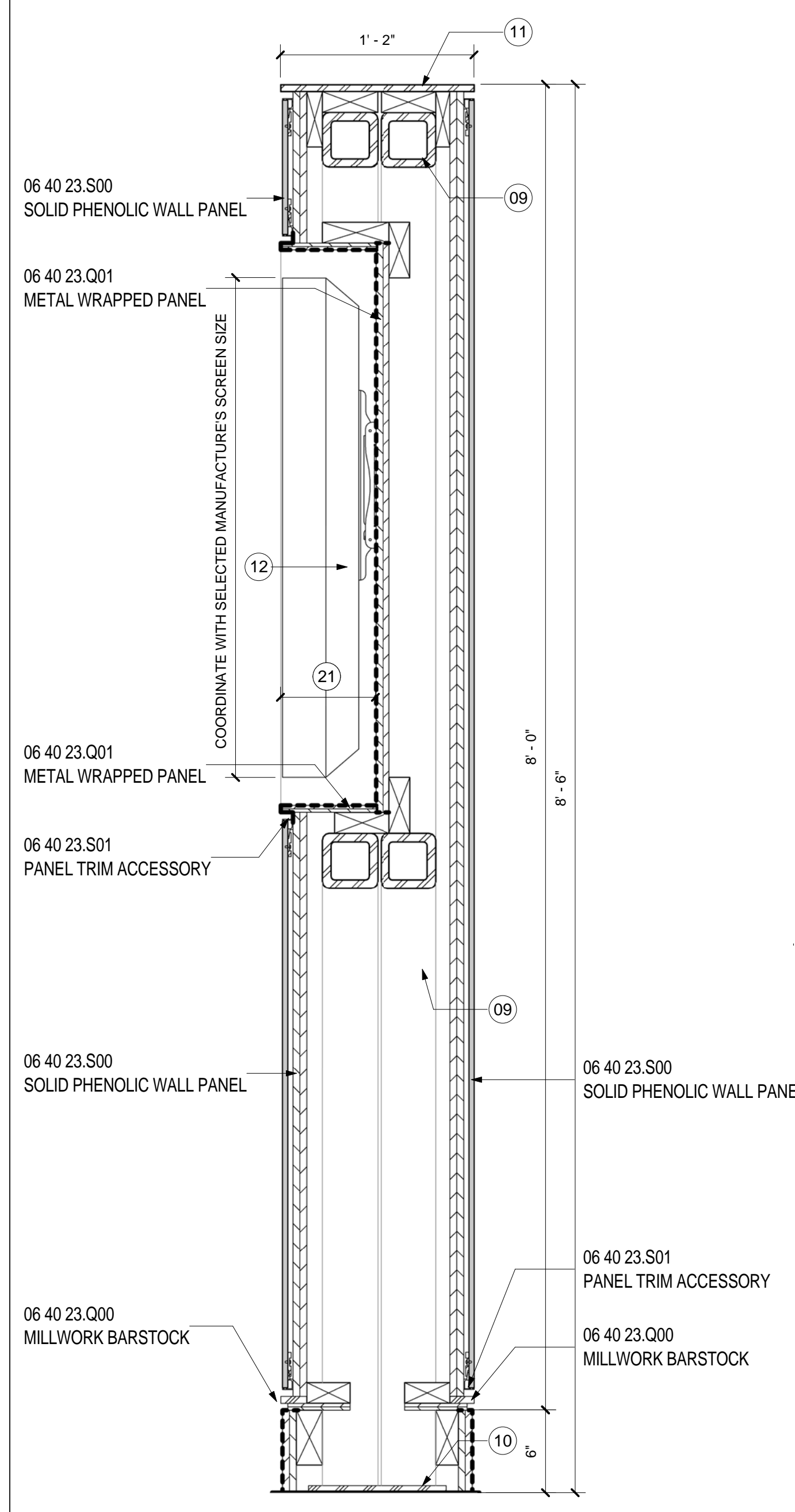

FIDS SECTION
SCALE: 1 1/2" = 1'-0" A12.92 6

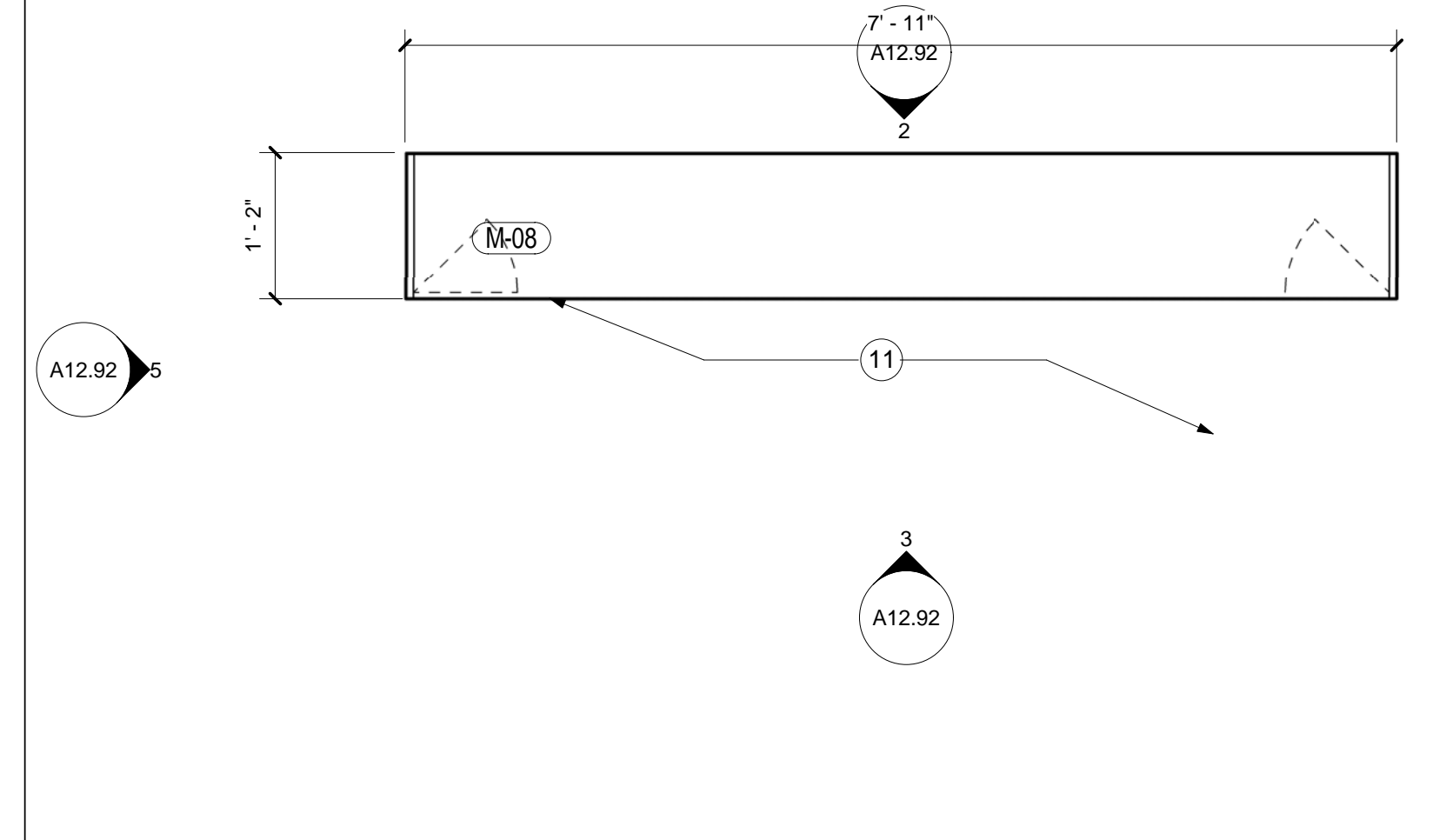

FIDS PLAN
SCALE: 3/4" = 1'-0" A02.03.02 1

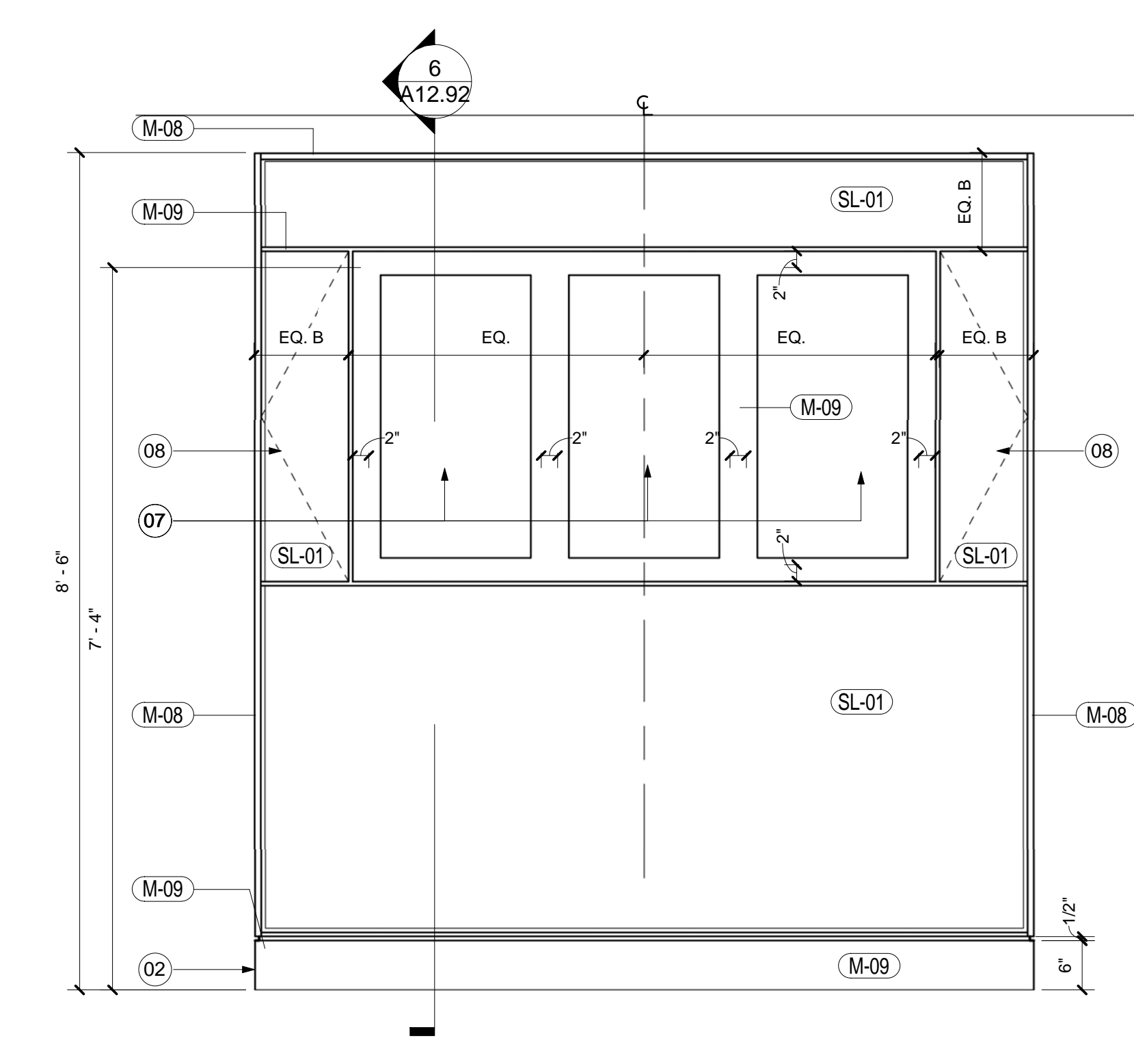

FIDS ELEV.
SCALE: 3/4" = 1'-0" A12.92 2

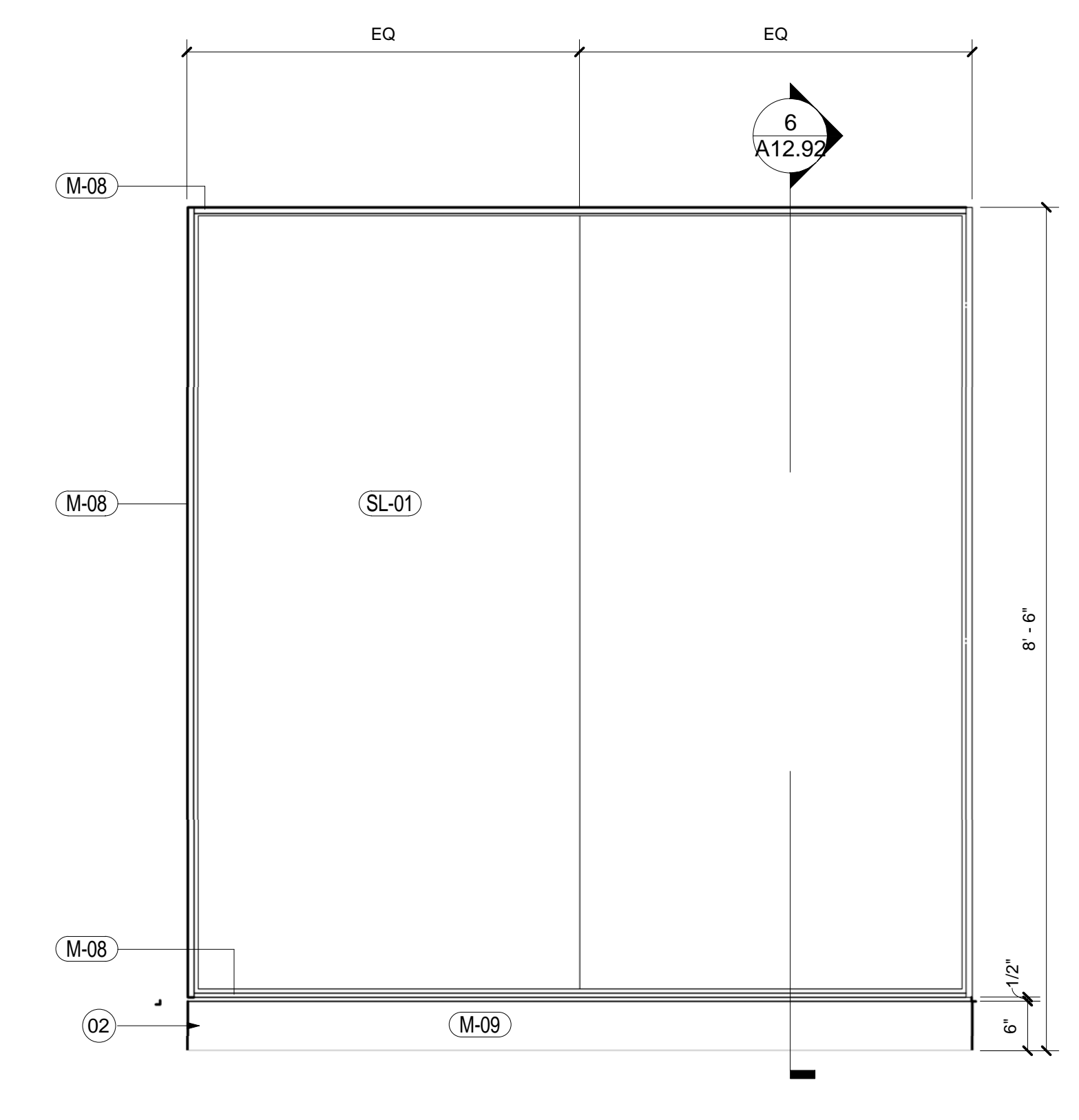

FIDS ELEV.
SCALE: 3/4" = 1'-0" A12.92 3

SHEET NOTES

- 01 AIR CARRIER STANDARD MILLWORK INSERT. CONTRACTOR TO PROVIDE AND VERIFY DIMENSIONS AND CONFIGURATION PRIOR TO FABRICATION
- 02 RUN METAL BASE CONTINUOUS TO MINIMIZE JOINTS
- 03 METAL SUPPORT AS REQUIRED; PAINTED P-01
- 04 COORDINATE EXTENT OF REQUIRED BACKWALL WITH AIR CARRIER'S EQPT/MILLWORK INSERTS
- 05 PROVIDE CUT OUT FOR CONCEALED ELECTRICAL DISTRIBUTION. COORDINATE MOUNTING AND ROUTING OF ELECTRICAL AND DATA.
- 06 AIR CARRIER PROVIDED EQUIPNET. CONTRACTOR TO PROVIDE AND VERIFY DIMENSIONS AND CONFIGURATION PRIOR TO FABRICATION
- 07 SCHEDULED EQUIPMENT. REFER TO A03 SERIES AND PROJECT MANUAL FOR ADDITIONAL INFORMATION
- 08 MILLWORK DOOR TO SWING INDEPENDENTLY OF METAL FRAME. HINGES AND MAGNETIC CATCH LATCH TO BE HIDDEN.
- 09 STEEL TUBE FRAMING AND CONNECTION TO BE DESIGNED, SIGNED AND SEALED AS PART OF MILLWORK PACKAGE
- 10 STEEL BASE PLATE SHALL NOT EXTEND PAST MILLWORK BASE
- 11 PROVIDE SLOT(S) FOR VENTILATION
- 12 FLIGHT INFORMATION DISPLAY SYSTEM. COORDINATE MOUNTING AND P&C. REFER TO TELECOMMUNICATION DRAWINGS FOR ADDITIONAL INFORMATION. NO EXPOSED WIRES.
- 13 STRUCTURAL STEEL. REFER TO STRUCTURAL DRAWINGS FOR ADDITIONAL INFORMATION
- 14 CONCEAL POWER AND DATA CABELING WITHIN STRUCTURAL STEEL
- 15 STAINLESS STEEL FOOTREST
- 16 3MM PVC EDGE TO MATCH ADJACENT PLAM
- 17 METAL ENCLOSURE PAINTED P-02
- 18 STAINLESS STEEL PULL
- 19 FAA REQUIRED SIGNAGE; REFER TO SIGNAGE AND WAYFIND DRAWINGS. COORDINATE MOUNTING AND RECESS DEPTH PRIOR TO FABRICATION
- 20 TSA PROVIDED LIGHT FIXTURE. COORDINATE ELECTRICAL WIRE ROUTING AND MOUNTING.
- 21 COORDINATE DEPTH WITH SELECTED SCREEN AND MOUNTING BRACKET
- 22 SELF SERVICE DEVICE (SSD) PROVIDED BY OTHERS. MILLWORKER TO COORDINATE OPENING DIMENSIONS AND WIRING ACCESS
- 23 PERFORATED ACCESS PANEL TO ALLOW ACCESS TO CPU DRIVER. COORDINATE WITH SCHEDULED EQUIPEMENT AND MOUNTING BRACKET
- 24 COORDINATE HEIGHT WITH AIRLINE EQUIPMENT
- 25 SCHEDULED FINISH FLOOR; REFER TO FINISH PLAN
- 26 SCHEDULED PARTITION; REFER TO CONSTRUCTION PLAN
- 27 PROVIDE REVEAL IN DOOR PANEL TO ALIGN WITH ADJACENT CABINET
- 28 ADJUSTABLE LEVELING GLIDES
- 29 SUPPORT PANEL CLADDED IN PLASTIC LAMINATE WITH 3MM PVC EDGE; COLOR TO MATCH ADJACENT LAMINATE
- 31 INSULATE DRAIN AND WATER SUPPLIES
- 32 SCHEDULED SINK; REFER TO PLUMBING DRAWINGS FOR FURTHER INFORMATION
- 33 SCHEDULED FAUCET SET; REFER TO PLUMBING DRAWINGS FOR FURTHER INFORMATION
- 34 SCHEDULED CEILING; REFER TO CONSTRUCTION PLAN
- 35 1.5" DIA. BULLNOSE PVC T-EDGE WITH FLUSH INSTALLATION
- 36 2" DIA. GROMMET
- 37 PROVIDE FINISHED CUT-OUT FOR CABLE MANAGEMENT; COORDINATE SIZE OF OPENING WITH WIRE MANAGEMENT DEVICE.

GENERAL NOTES

- A COORDINATE ALL CLEAR WIDTHS WITH AIRLINE'S EQPT/MILLWORK INSERTS PRIOR TO FABRICATION.
- B ALL CABINET INTERIORS TO BE PL-01 U.O.N
- C REFER TO EQUIPMENT SCHEDULE IN PROJECT MANUAL APPENDIX A.
- D EASE ALL EXPOSED STAINLESS STEEL BARSTOCK EDGES

Portland International
Jetport
1001 Westbrook Street
Portland, Maine 04102

Gensler
2020 K Street, Northwest
Suite 200
Washington DC 20006
Telephone 202.721.5200
Facsimile 202.872.8587

Date	Description
01/23/09	95% CONSTRUCTION DOCUMENTS
10/26/09	ISSUED FOR PERMIT
145 09/01/11	ISSUED FOR CONSTRUCTION

Seal/Signature

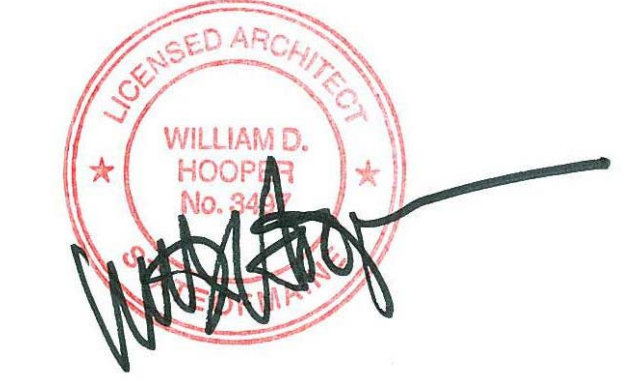

Project Name
PWM Terminal Enhancement

Project Number
09.6395.000

Description
MILLWORK DETAILS

Scale
As indicated

A12.92

© 2009 Gensler