

TYPE	STUD SIZE	STUD GA	STUD SPACING	GYP BD THK/TYP	WALL THK	ATTENUATION THICKNESS	FIRE RATING	UL NUMBER	STC RATING
Q3A	3 5/8"	20	16"	5/8"	RE. PLAN	3 1/2" BATT	3HR	U419	-

PARTITION TYPE Q
SCALE: 3" = 1'-0"

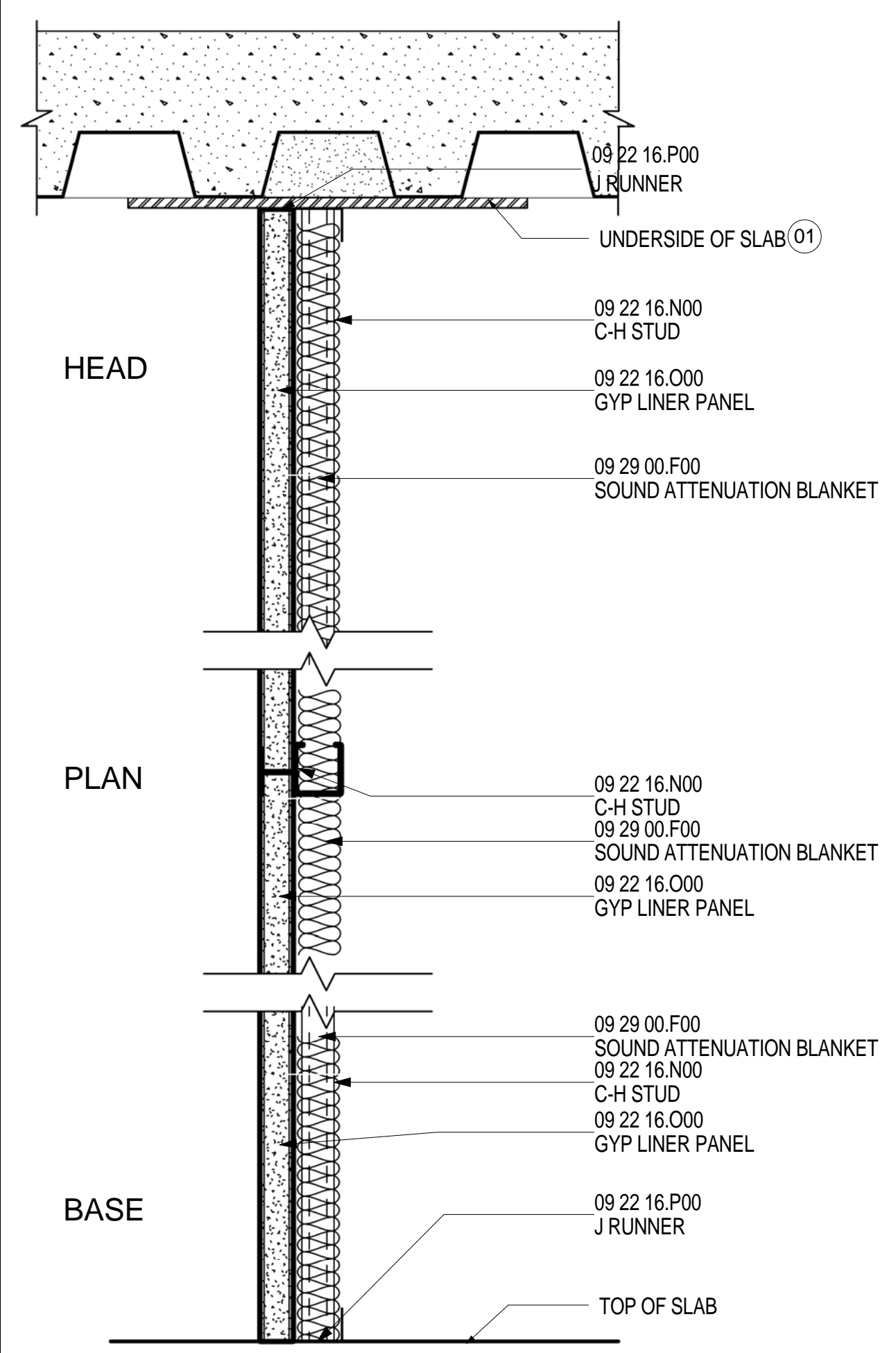

TYPE	STUD SIZE	STUD GA	STUD SPACING	GYP BD THK/TYP	WALL THK	ATTENUATION THICKNESS	FIRE RATING	UL NUMBER	STC RATING
NEA	6"	20	24" OC	1"	6"	2" BATT	-	-	-

PARTITION TYPE N
SCALE: 3" = 1'-0"

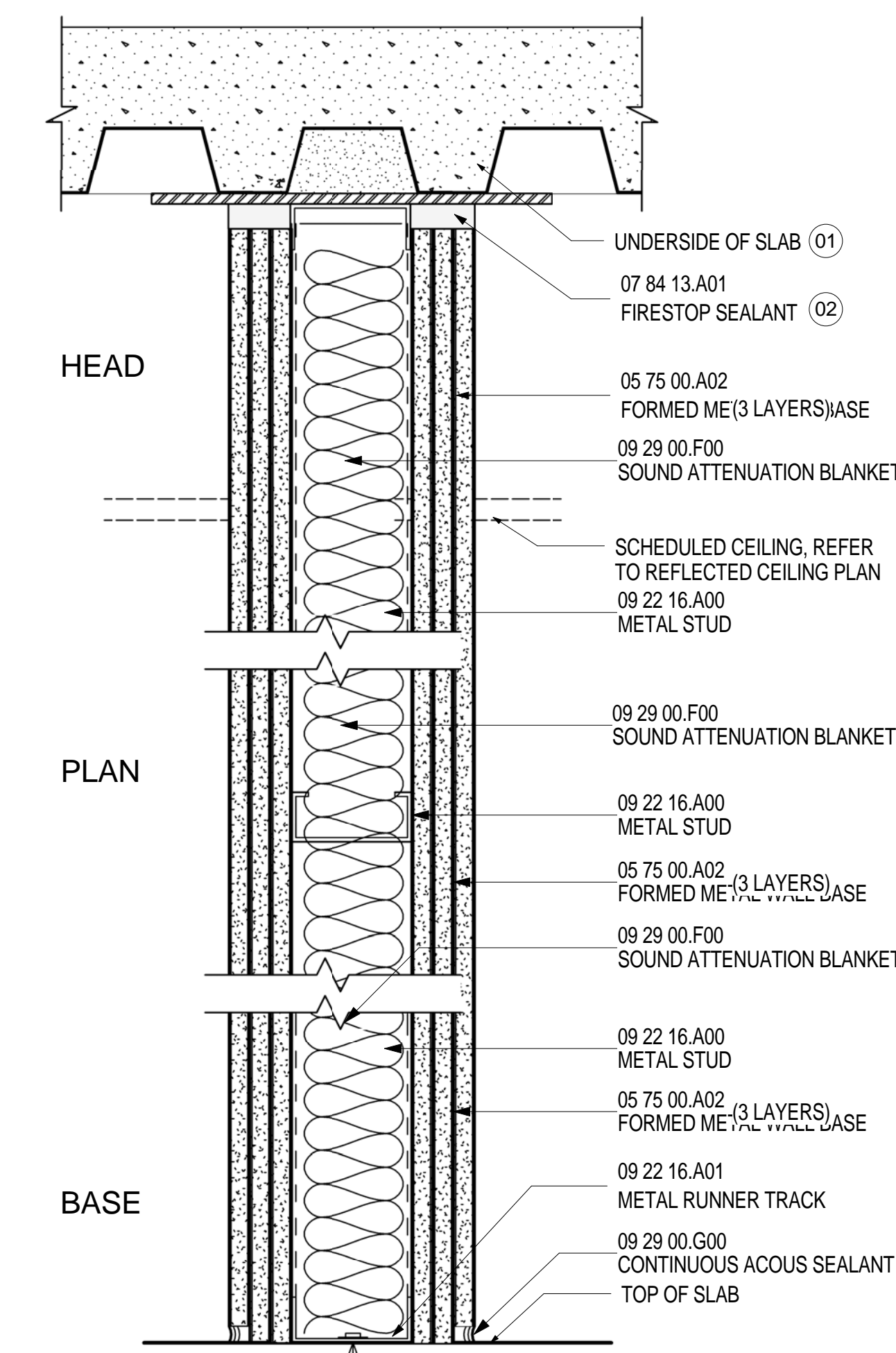

TYPE	STUD SIZE	STUD GA	STUD SPACING	GYP BD THK/TYP	WALL THK	ATTENUATION THICKNESS	FIRE RATING	UL NUMBER	STC RATING
L3A	3 5/8"	20	16"	5/8"	7 3/8"	3 1/2" BATT	3HR	U419	-
L3B	3 5/8"	20	16"	**AR 5/8"	7 3/8"	3 1/2" BATT	3HR	U419	-

PARTITION TYPE L
SCALE: 3" = 1'-0"

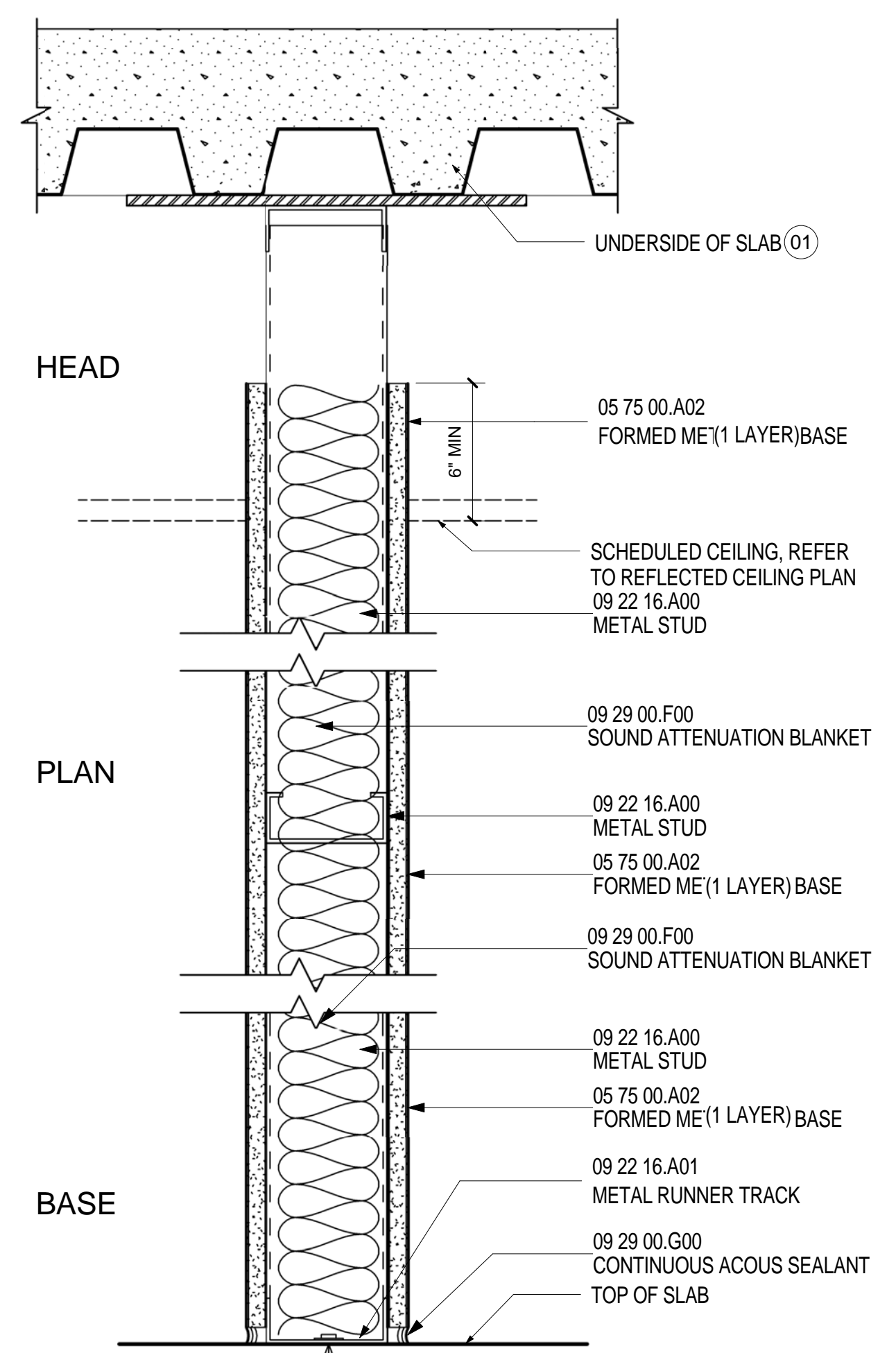

TYPE	STUD SIZE	STUD GA	STUD SPACING	GYP BD THK/TYP	WALL THK	ATTENUATION THICKNESS	FIRE RATING	UL NUMBER	STC RATING
R3A	3 5/8"	20	16" OC	5/8"	4 7/8"	3 1/2" BATT	-	-	-

PARTITION TYPE R
SCALE: 3" = 1'-0"

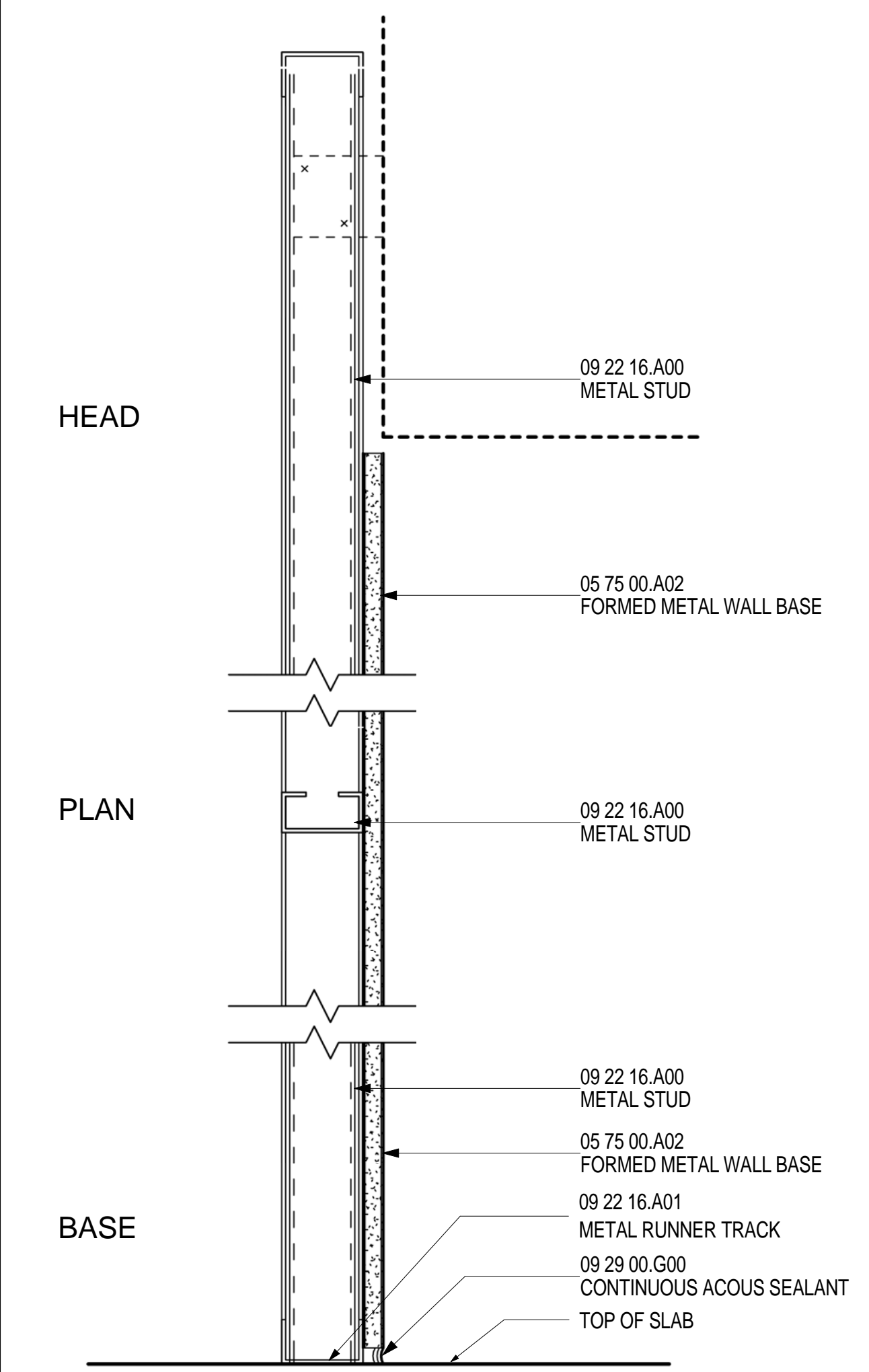

TYPE	STUD SIZE	STUD GA	STUD SPACING	GYP BD THK/TYP	WALL THK	ATTENUATION THICKNESS	FIRE RATING	UL NUMBER	STC RATING
P3A	3 5/8"	20	16" OC	5/8"	4 1/4"	-	-	-	-

PARTITION TYPE P (DEMISING)
SCALE: 3" = 1'-0"

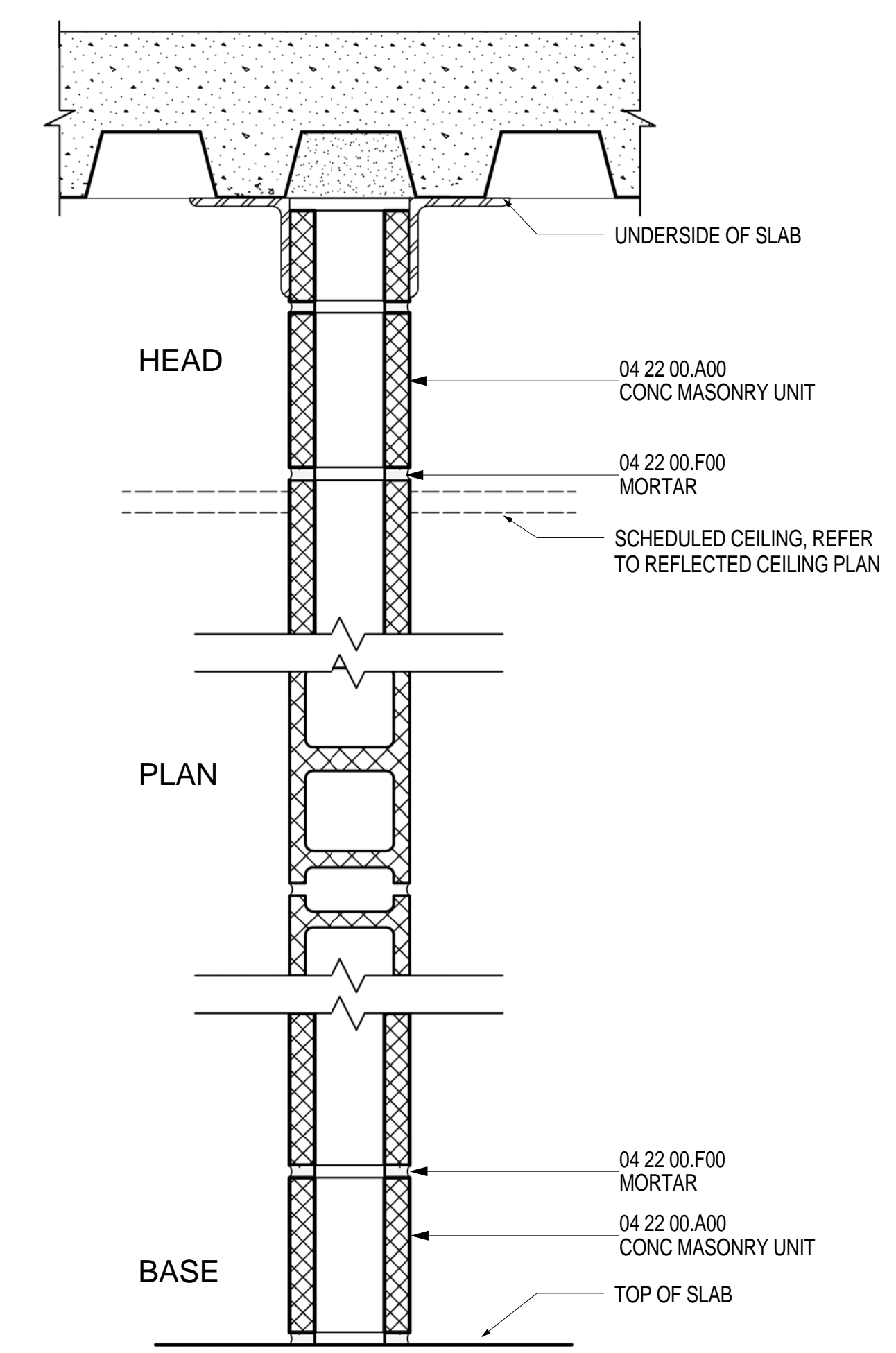

TYPE	BLOCK SIZE	WALL THK	FIRE RATING	UL NUMBER	STC RATING
M1A	8"	-	-	-	-
M1B	8"	-	2 HR	U901	-
M2	8"	-	3 HR	U901	-
M3	12"	-	2 HR	U901	-

PARTITION TYPE M
SCALE: 3" = 1'-0"

SHEET NOTES

- 01 16 GA CLOSURE PLATE AS REQUIRED TO ATTACHED TOP TRACK TO METAL DECK, TYP.
- 02 FIRE SAFING AS REQUIRED TO MAINTAIN RATING.
- 03 FLUSH WALL BASE WHERE OCCURS. COORDINATE WITH FINISHES AND DETAILS.
- 04 RUN GYPSUM BOARD TO UNDERSIDE OF SLAB AT SPECIFIED WALL TYPES.

GENERAL NOTES

Portland International Jetport
1001 Westbrook Street
Portland, Maine 04102

Gensler
2020 K Street, Northwest
Suite 200
Washington, DC 20006
Telephone 202.721.5200
Facsimile 202.872.8587

Date	Description
01/23/09	95% CONSTRUCTION DOCUMENTS
10/26/09	ISSUED FOR PERMIT
2 11/12/09	ADDENDUM #2
145 09/01/11	ISSUED FOR CONSTRUCTION

Seal/Signature

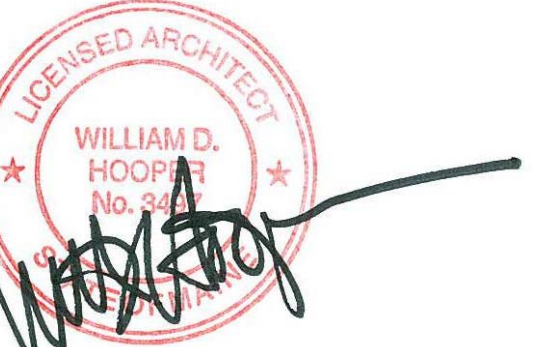

Project Name
PJM Terminal Enhancement

Project Number
09.6395.000

Description
PARTITION TYPES

Scale
3" = 1'-0"

A12.61

© 2009 Gensler