

**SHEET NOTES**

**Portland International  
Jetport**  
1001 Westbrook Street  
Portland, Maine 04102

**Gensler**  
2020 K Street, Northwest  
Suite 200  
Washington DC 20006  
Telephone 202.721.5200  
Facsimile 202.872.8587

Date	Description
57 11/19/10	BULLETIN #49
145 08/01/11	ISSUED FOR CONSTRUCTION

Seal/Signature

**Project Name**  
PWM Terminal Enhancement

**Project Number**  
09.6395.000

**Description**  
INTERIOR ELEVATIONS AND DETAILS - TSA SECURITY SCREEN

**Scale**  
As indicated

**A11.25**

© 2009 Gensler

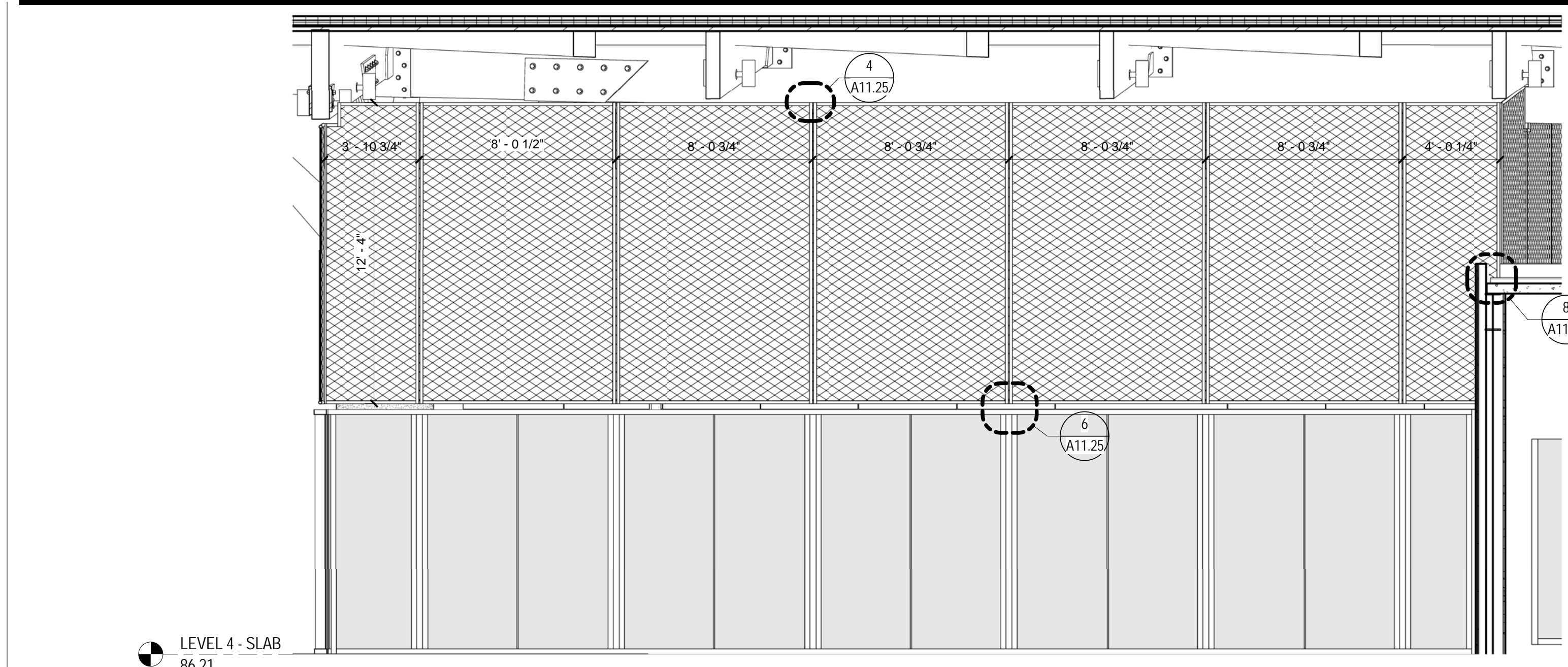

**METAL MESH TRELLIS - 2**  
SCALE: 1/4" = 1'-0"

A02.04.04

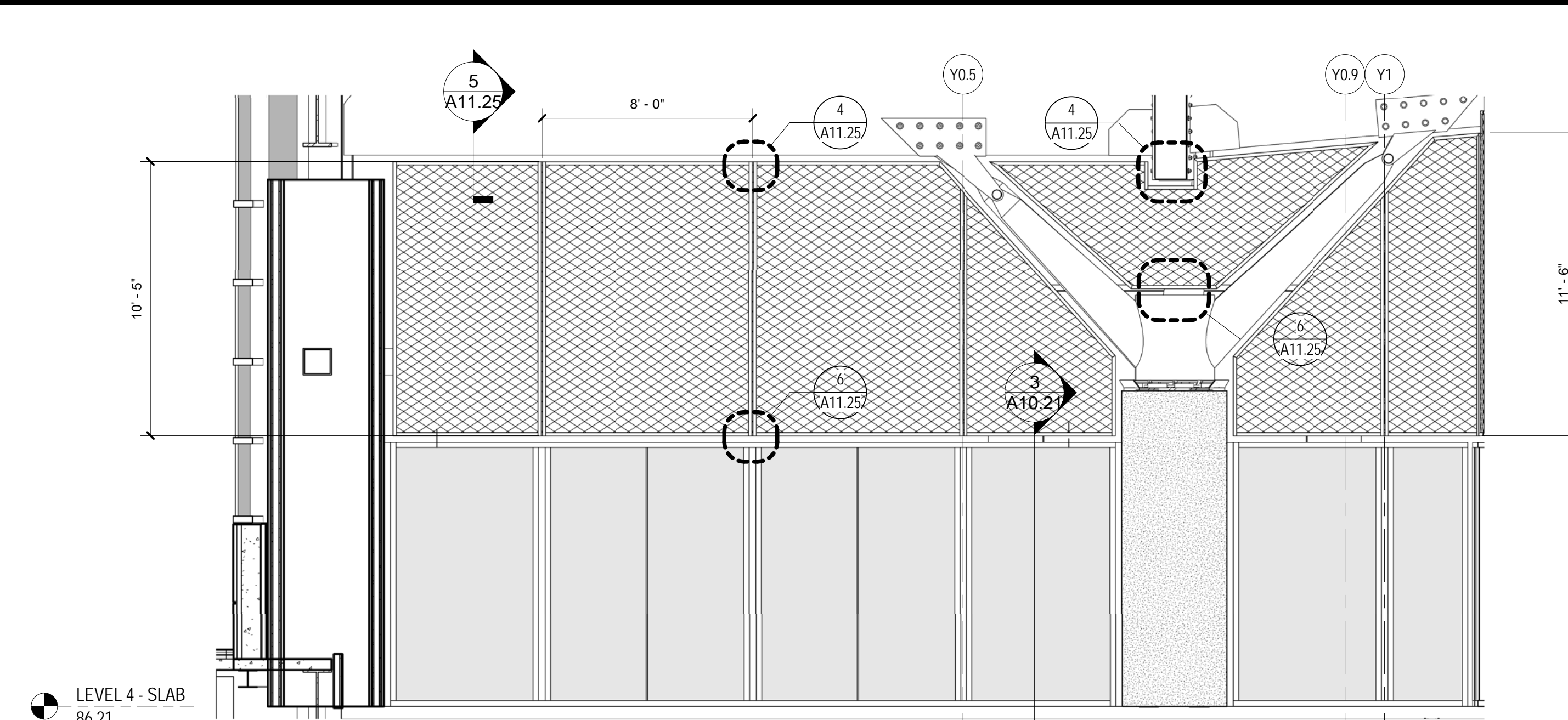

**2 METAL MESH TRELLIS**  
SCALE: 1/4" = 1'-0"

A02.04.04

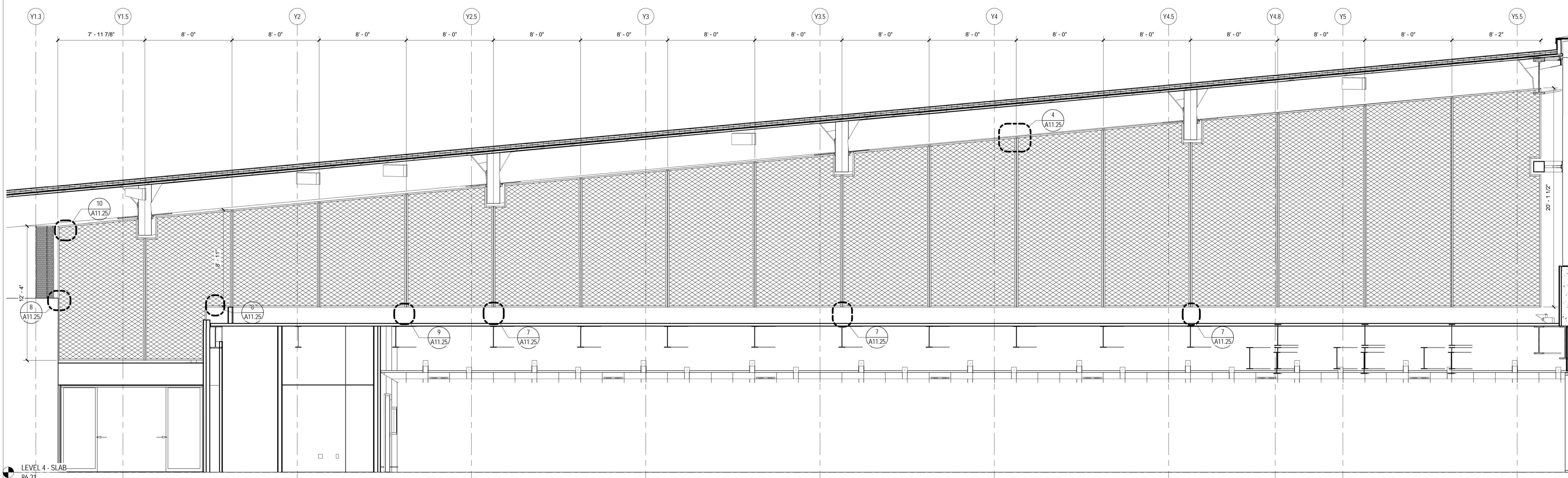

**METAL MESH TRELLIS - 1**  
SCALE: 1/4" = 1'-0"

A02.04.04

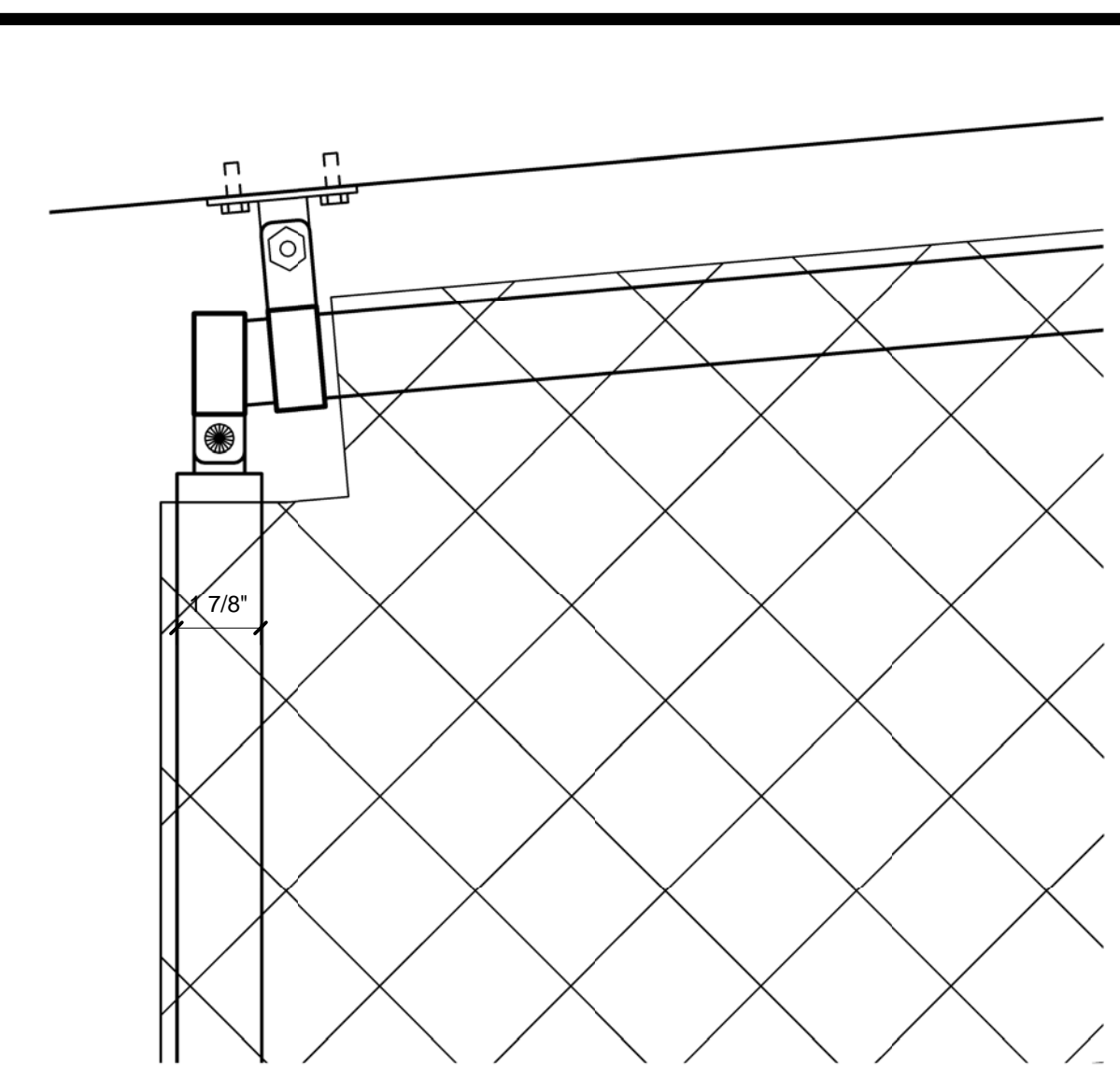

**DETAIL @ TOP CORNER**  
SCALE: 3" = 1'-0" A11.25 10

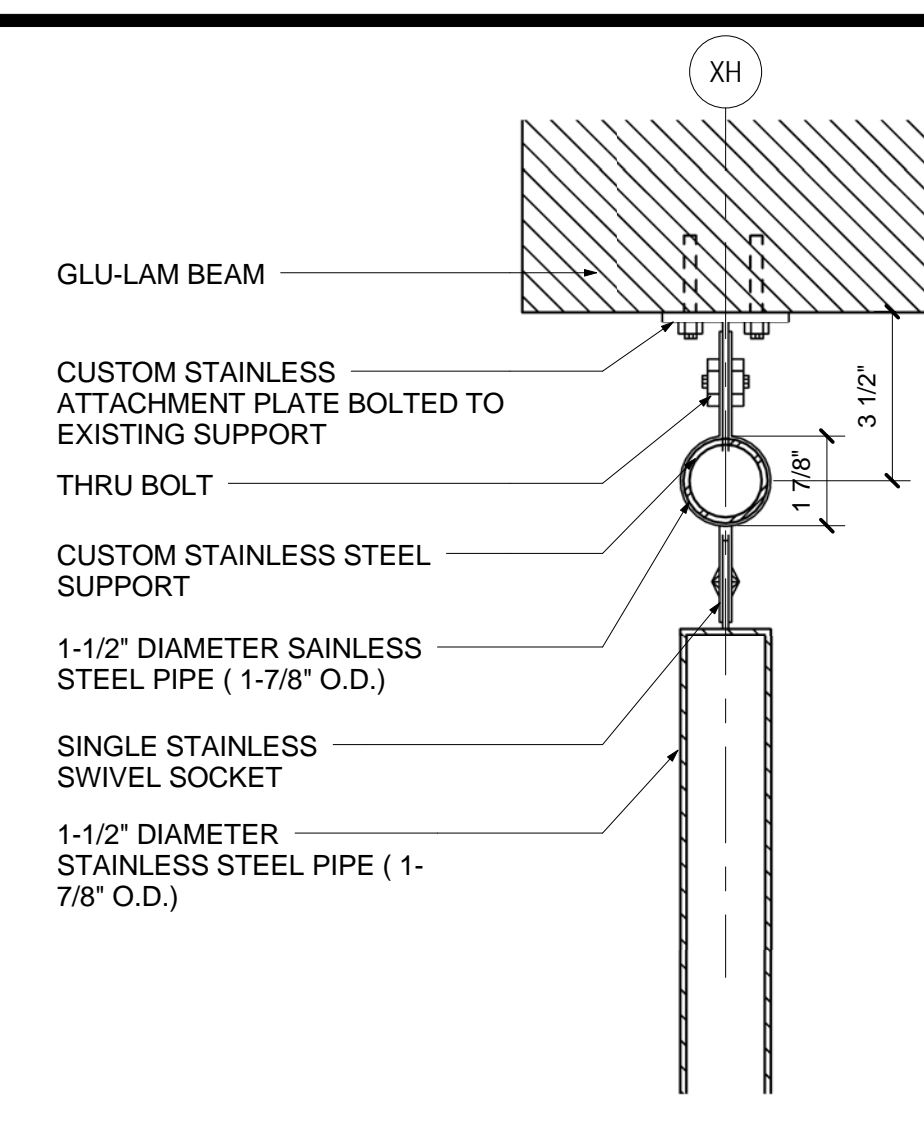

**SECTION @ GLU-LAM**  
SCALE: 3" = 1'-0" A11.10

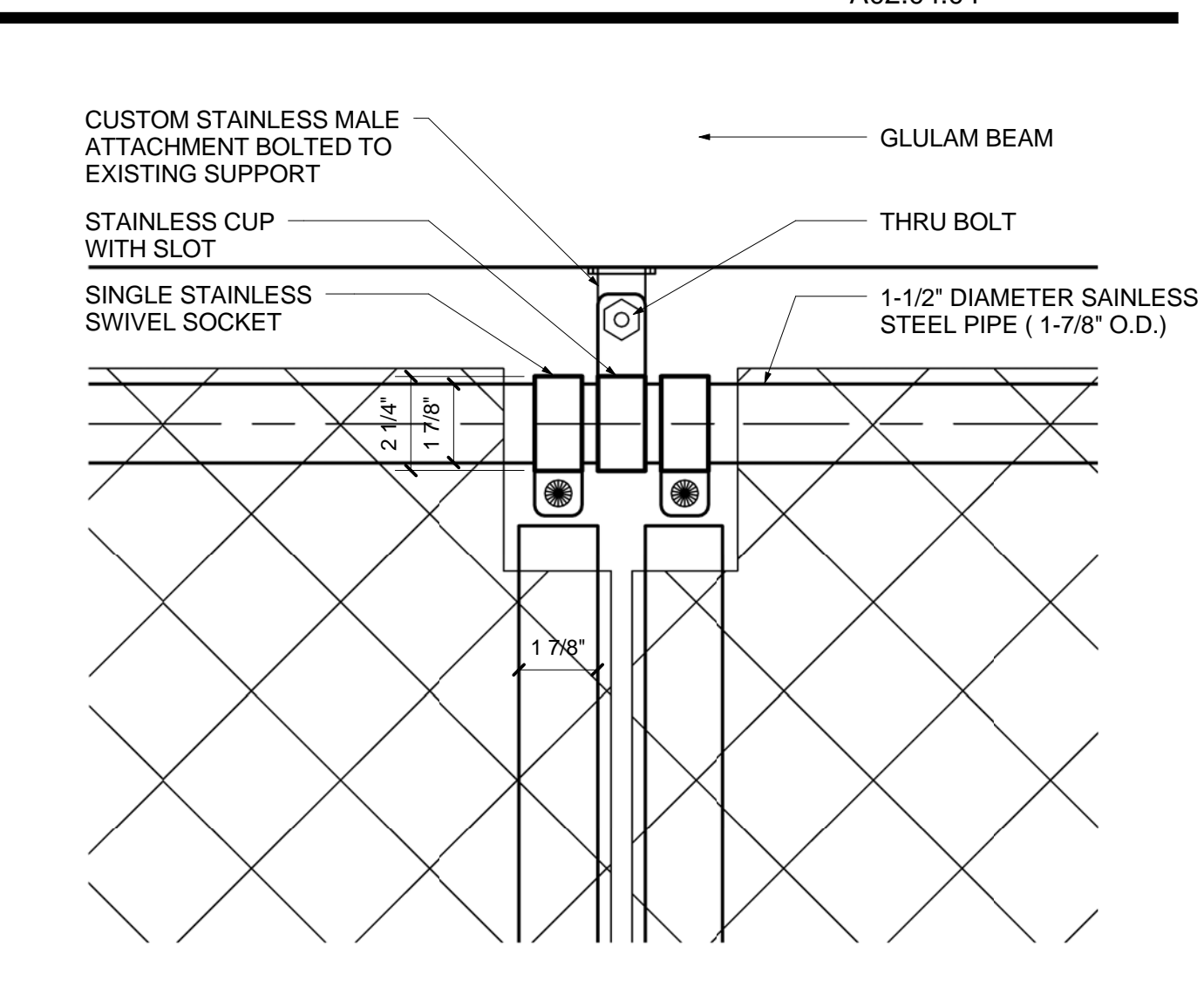

**5 DETAIL @ GLU-LAM ATTACHMENT**  
SCALE: 3" = 1'-0" A11.25 4

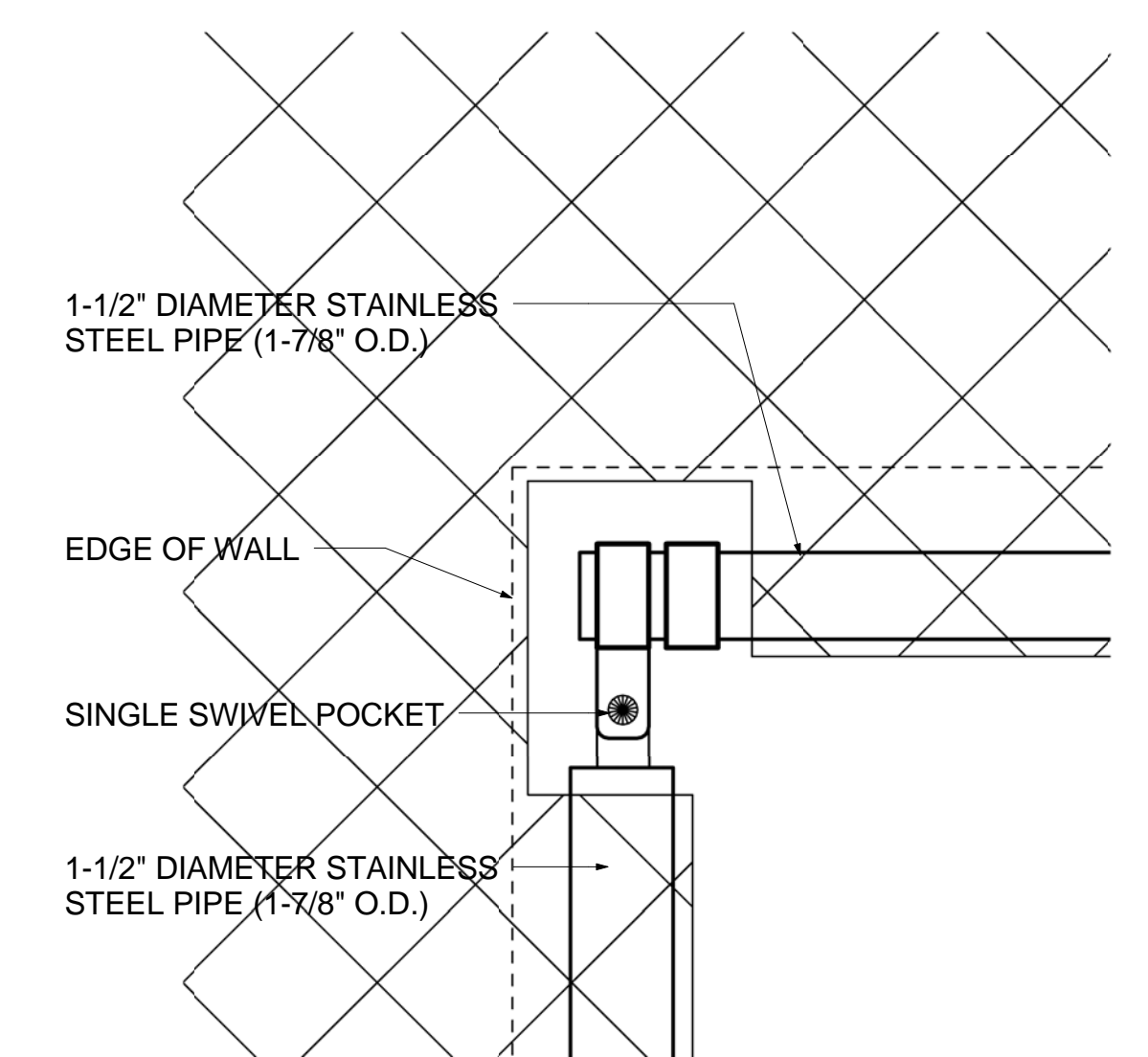

**DETAIL @ CORNER ATTACHMENT**  
SCALE: 3" = 1'-0" A11.25 8

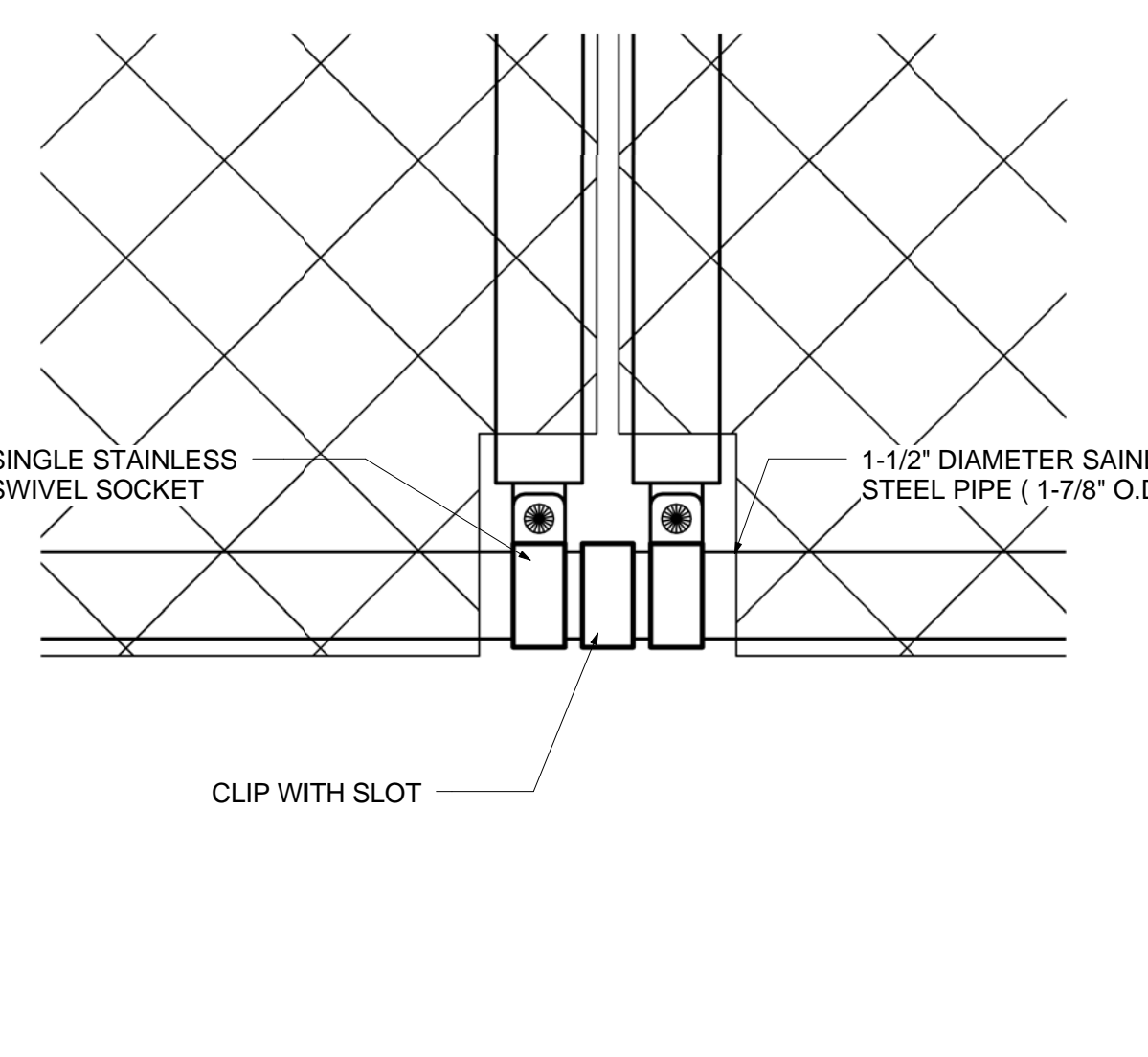

**DETAIL @ FENCE ATTACHMENT**  
SCALE: 3" = 1'-0" A11.25 9

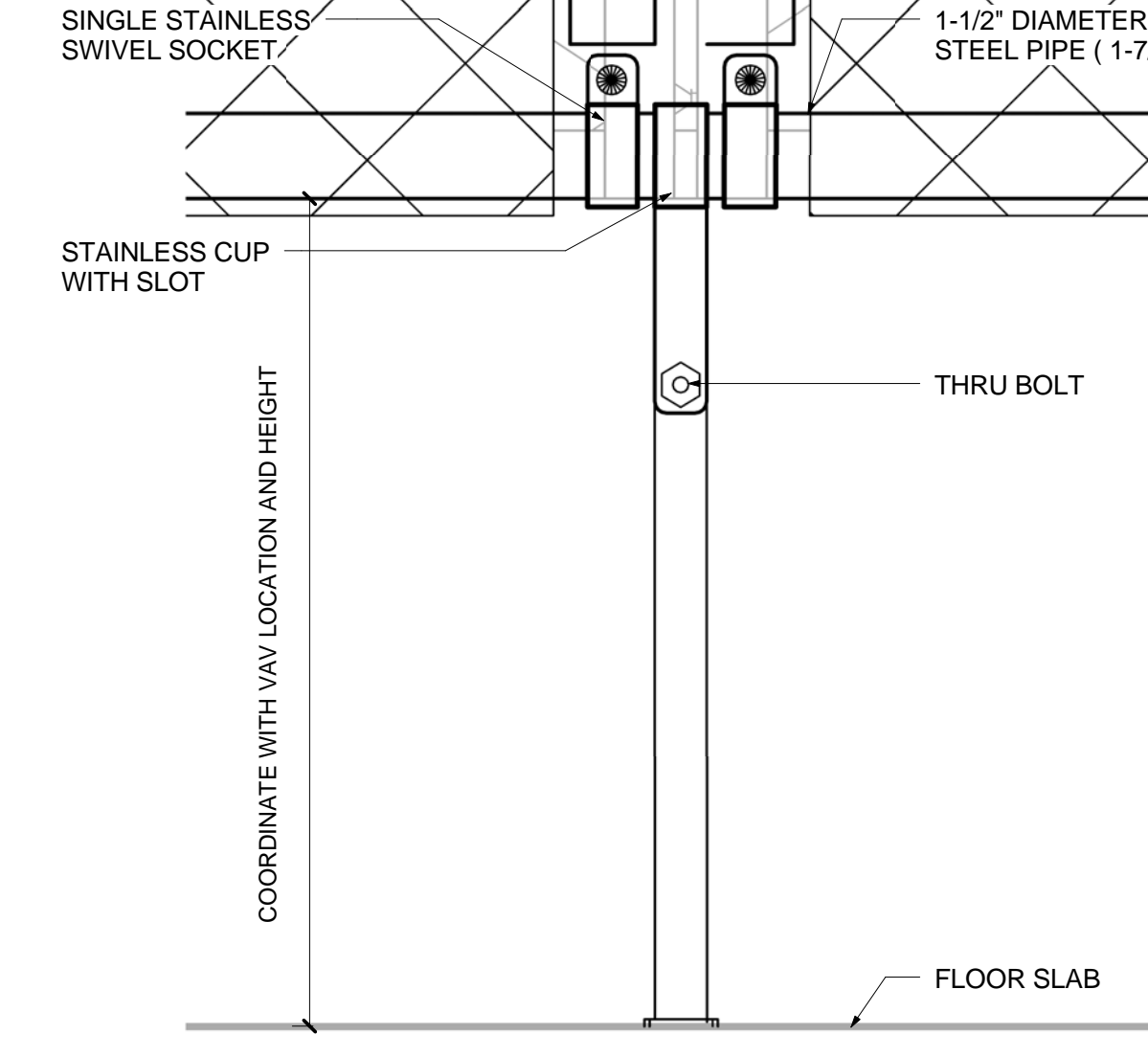

**DETAIL @ SLAB ATTACHMENT**  
SCALE: 3" = 1'-0" A11.25

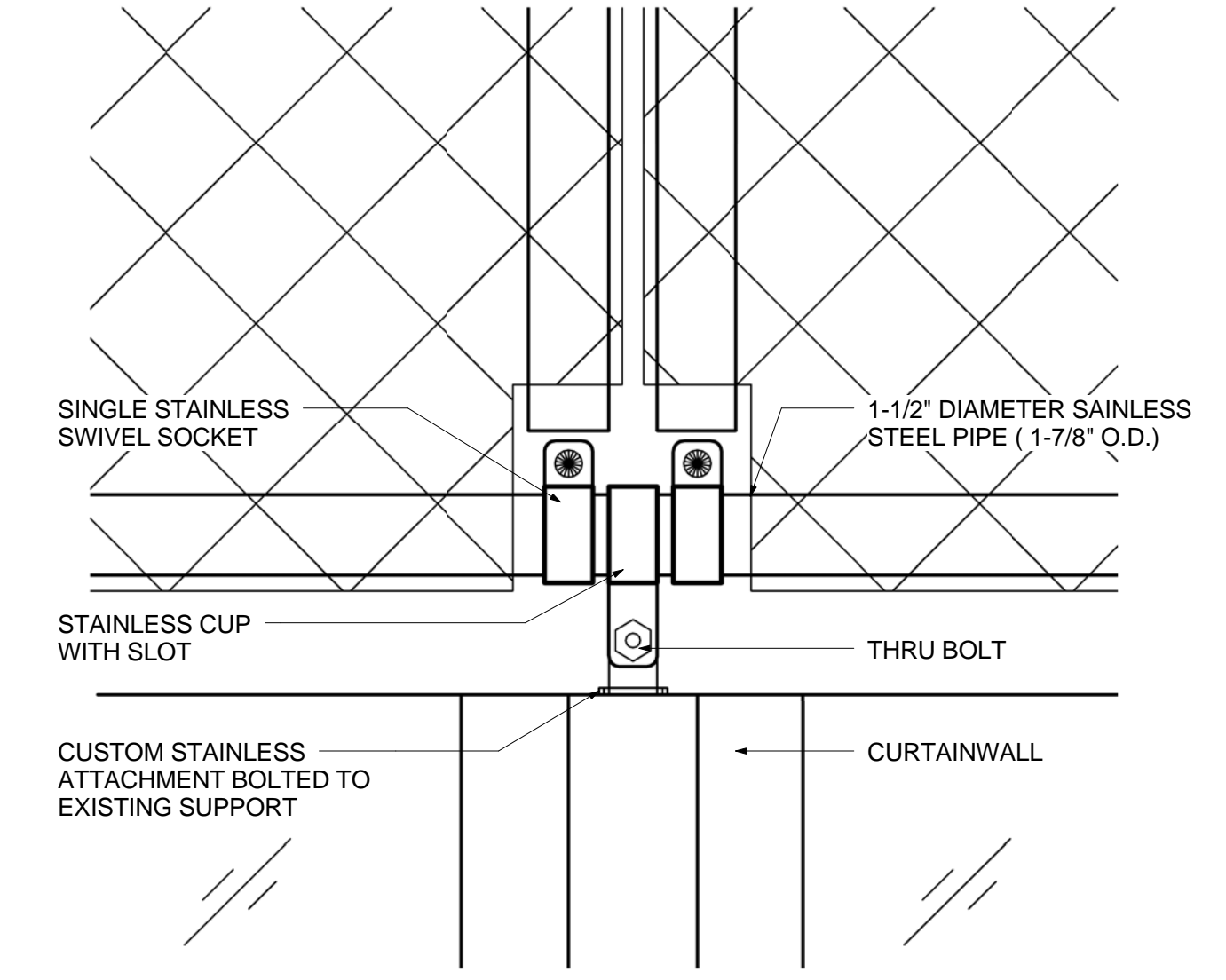

**7 DETAIL @ CURTAINWALL ATTACHMENT**  
SCALE: 3" = 1'-0" A11.25 6

**GENERAL NOTES**