

1 DETAIL SECTION 301-CONVEYOR AND CATWALK HANGER DOUBLE SILL SUPPORT
B12.02 3/4"=1'-0"

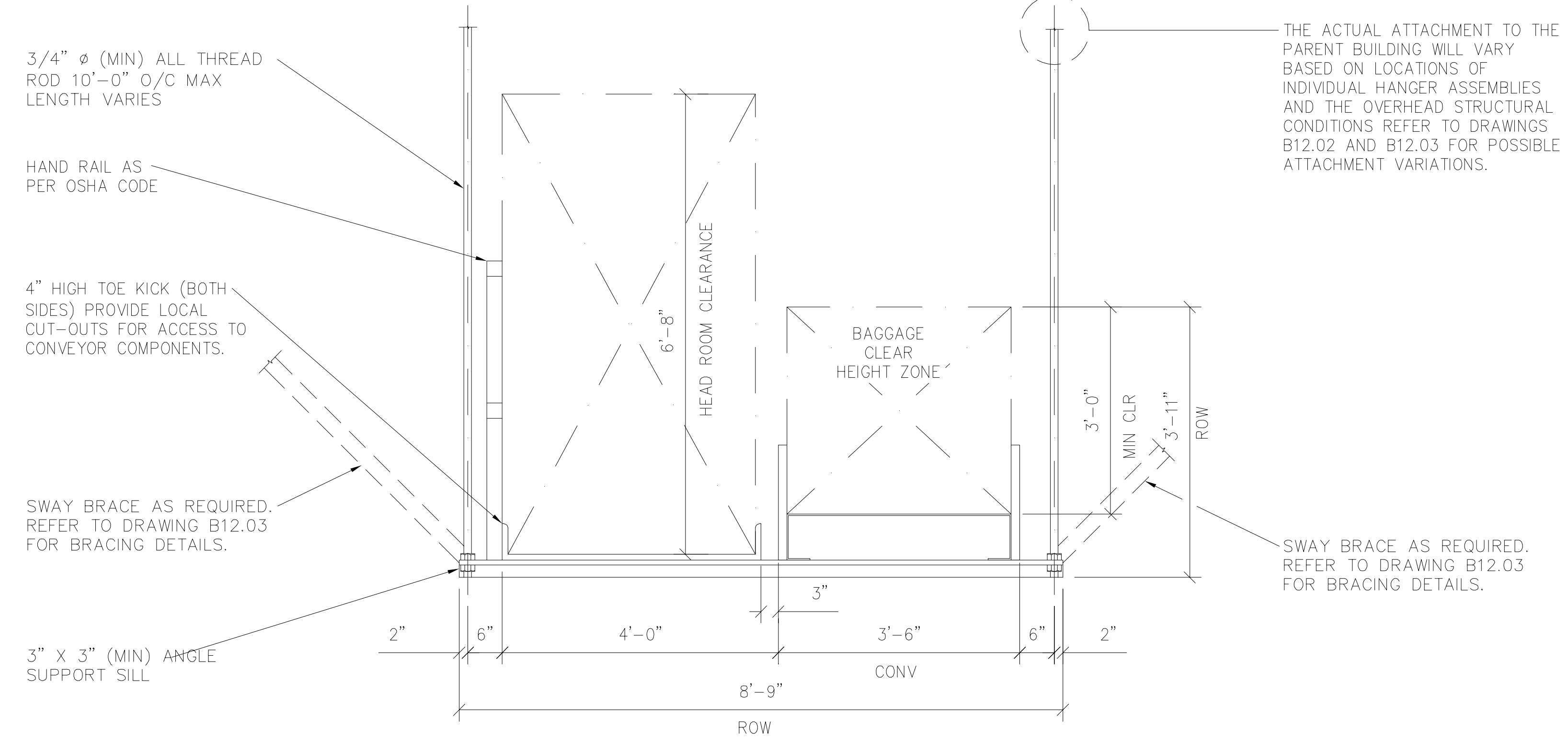

2 DETAIL SECTION - CONVEYOR AND CATWALK HANGER SINGLE SILL SUPPORT
B12.02 3/4"=1'-0"

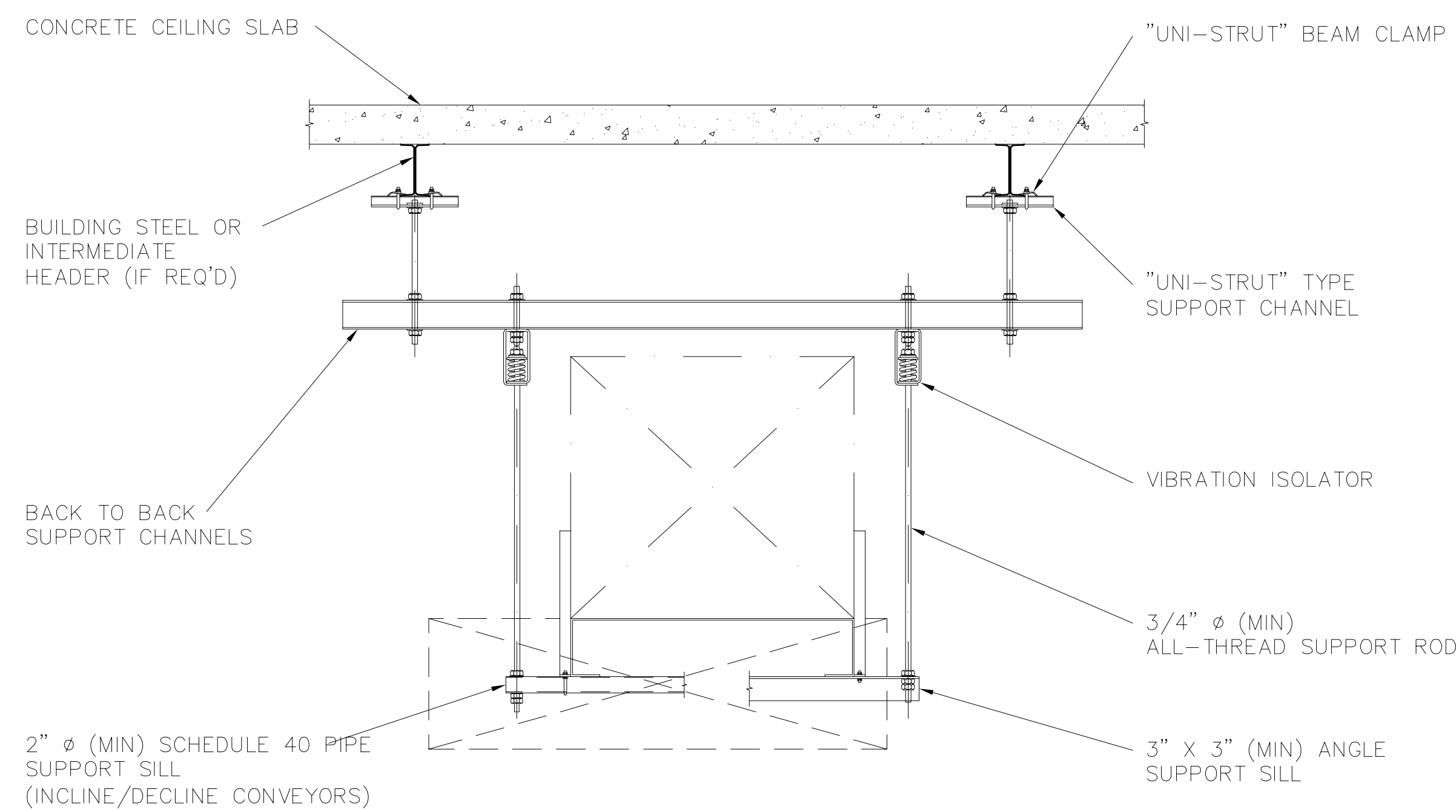

3 DETAIL SECTION - HEADER ATTACHMENT LAYOUT WITH/WITHOUT SWAY BRACING
B12.02 3/4"=1'-0"

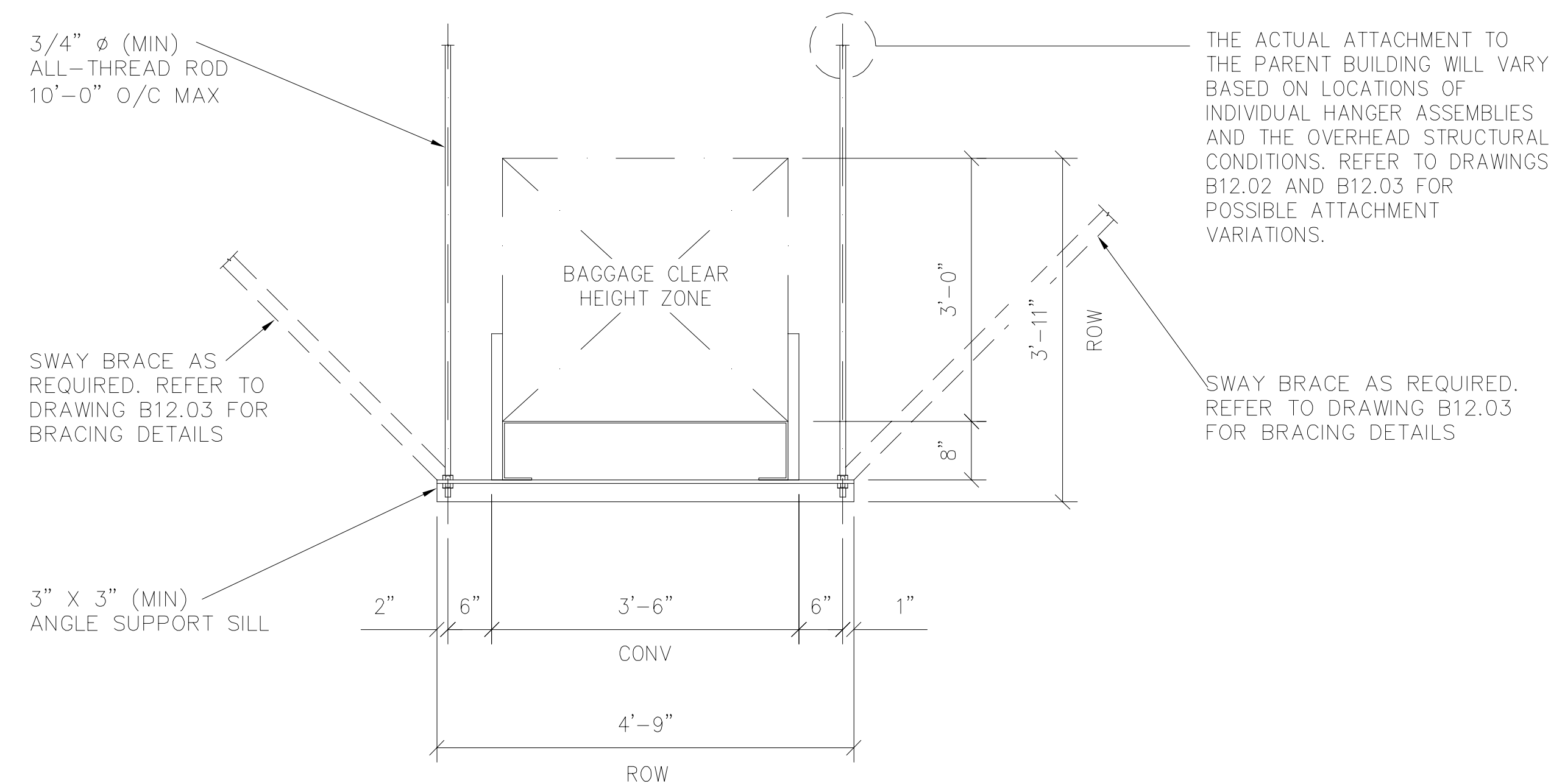

4 DETAIL SECTION - STANDARD CONVEYOR HANGER DETAIL
B12.02 3/4"=1'-0"

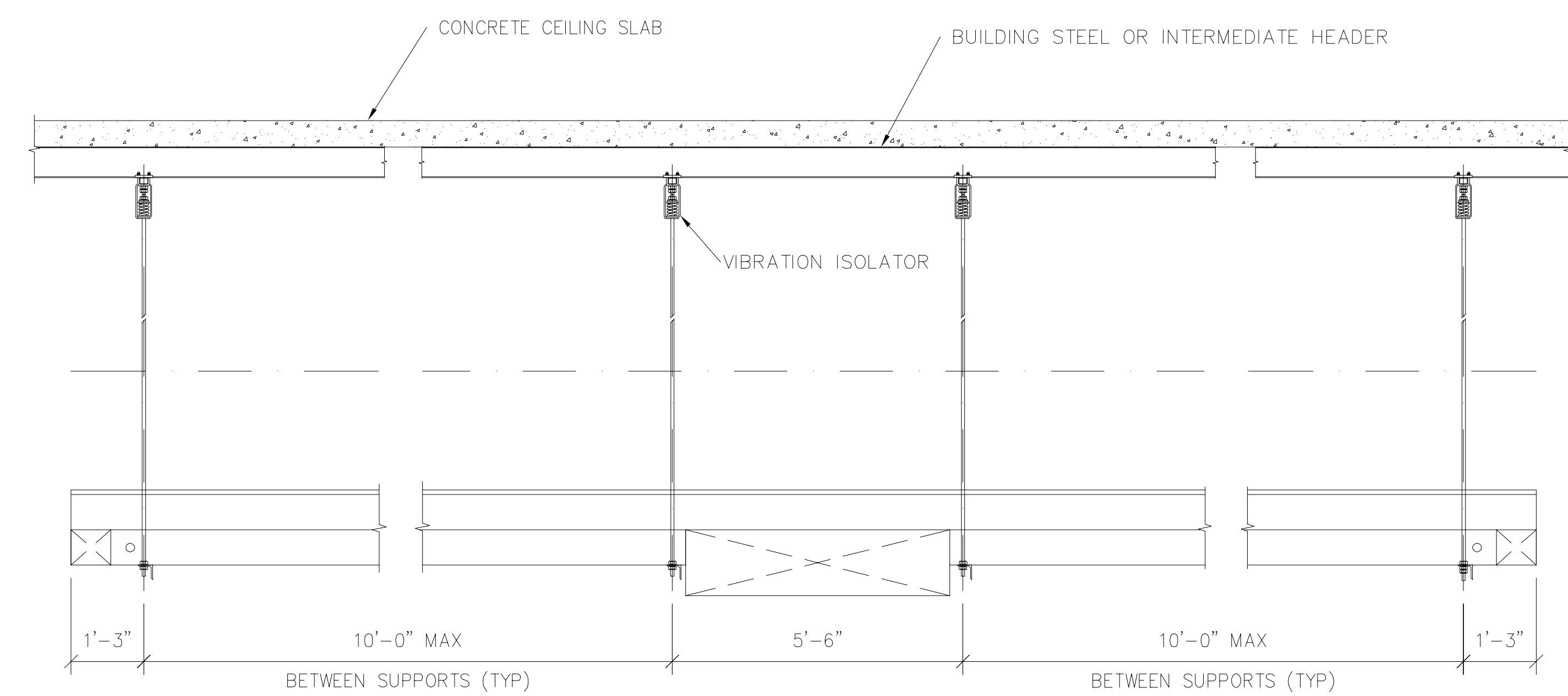

5 DETAIL ELEVATION-CONVEYOR SUPPORT USING "UNI-STRUT" BEAM CLAMPS AND VIBRATION ISOLATORS
B12.02 1/2"=1'-0"

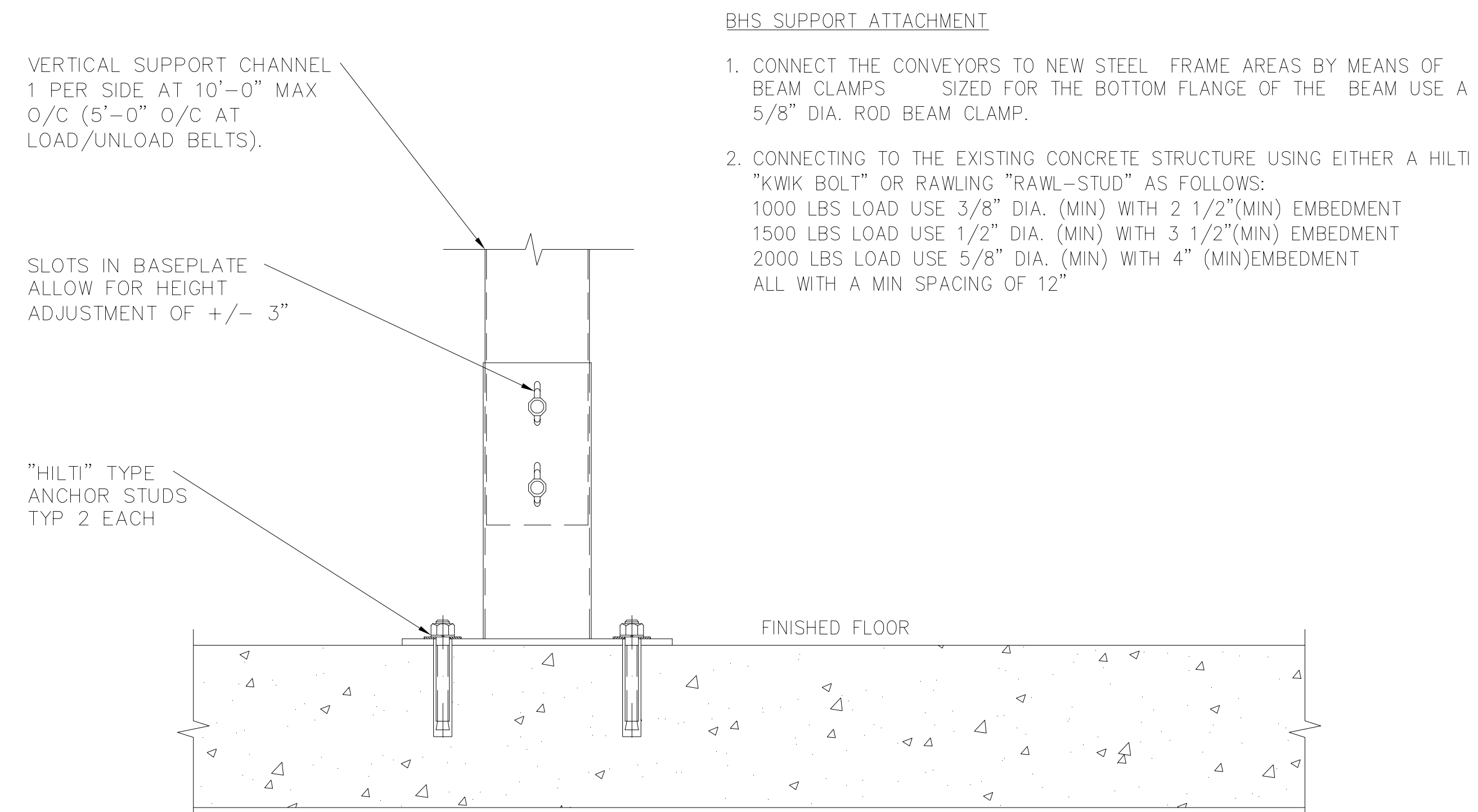

6 DETAIL SECTION-FLOOR SUPPORTED CONVEYOR LEG ATTACHMENT
B12.02 3"=1'-0"

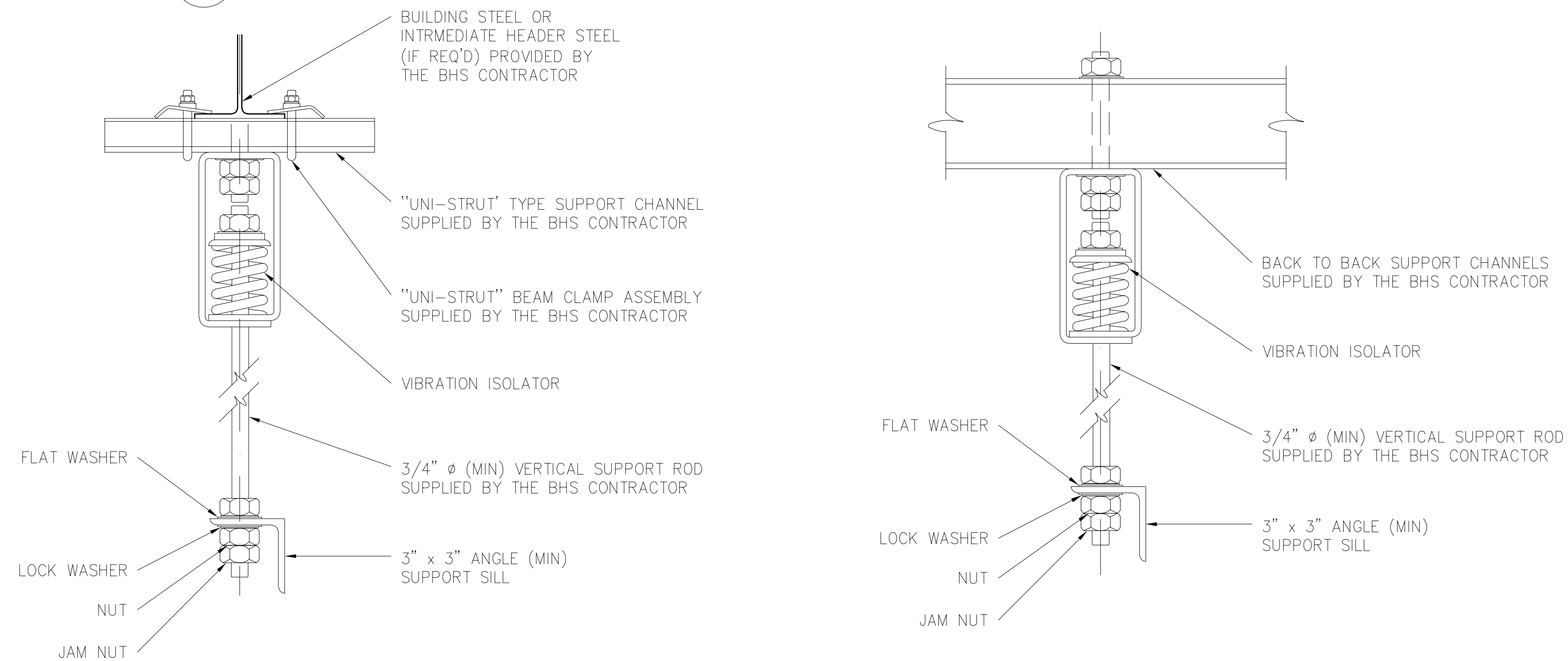

7 DETAIL SECTION-HANGER APPLICATION AT BUILDING STEEL
B12.02 3"=1'-0"

8 DETAIL SECTION-HANGER APPLICATION AT BACK TO BACK CHANNEL HEADERS
B12.02 3"=1'-0"

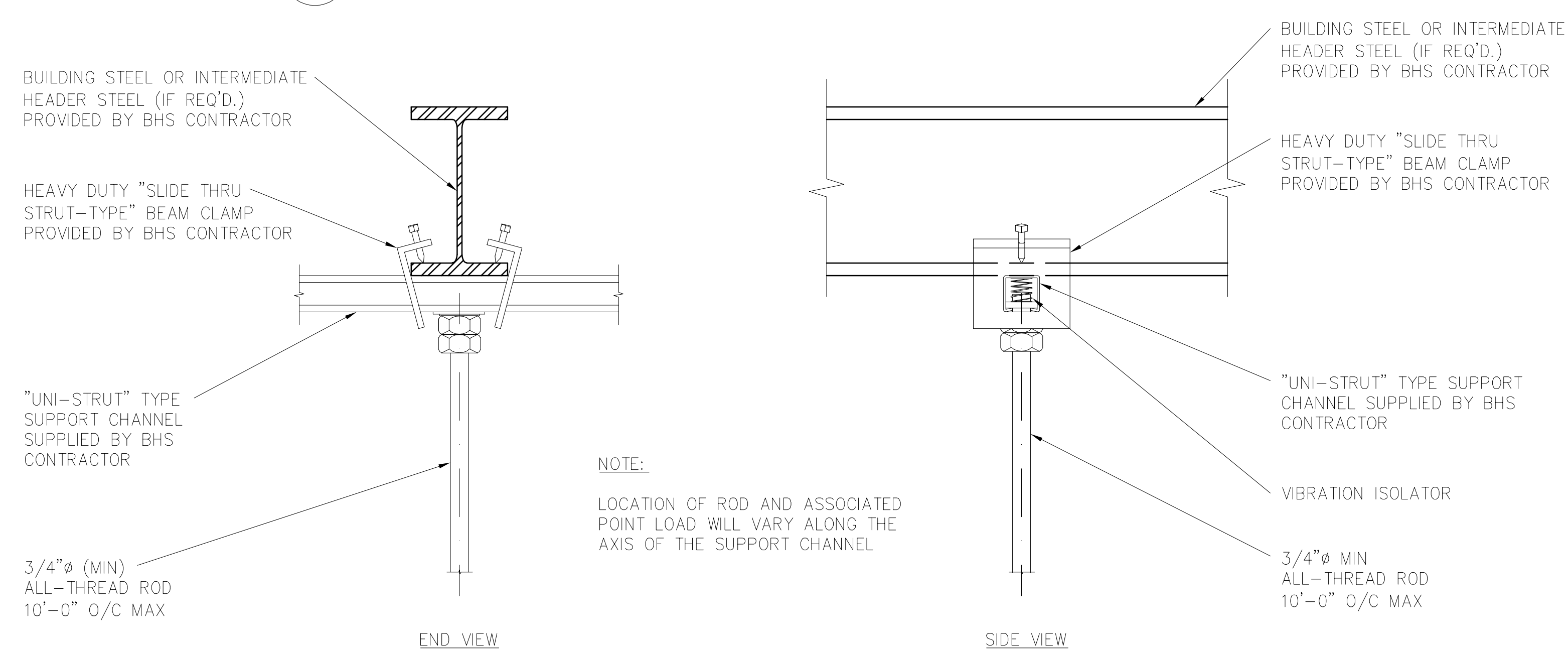

9 DETAIL SECTIONS-BHS HEADER STEEL ATTACHMENT DETAIL-BEAM CLAMP "A"
B12.02 3"=1'-0"

SHEET NOTES

LEGEND

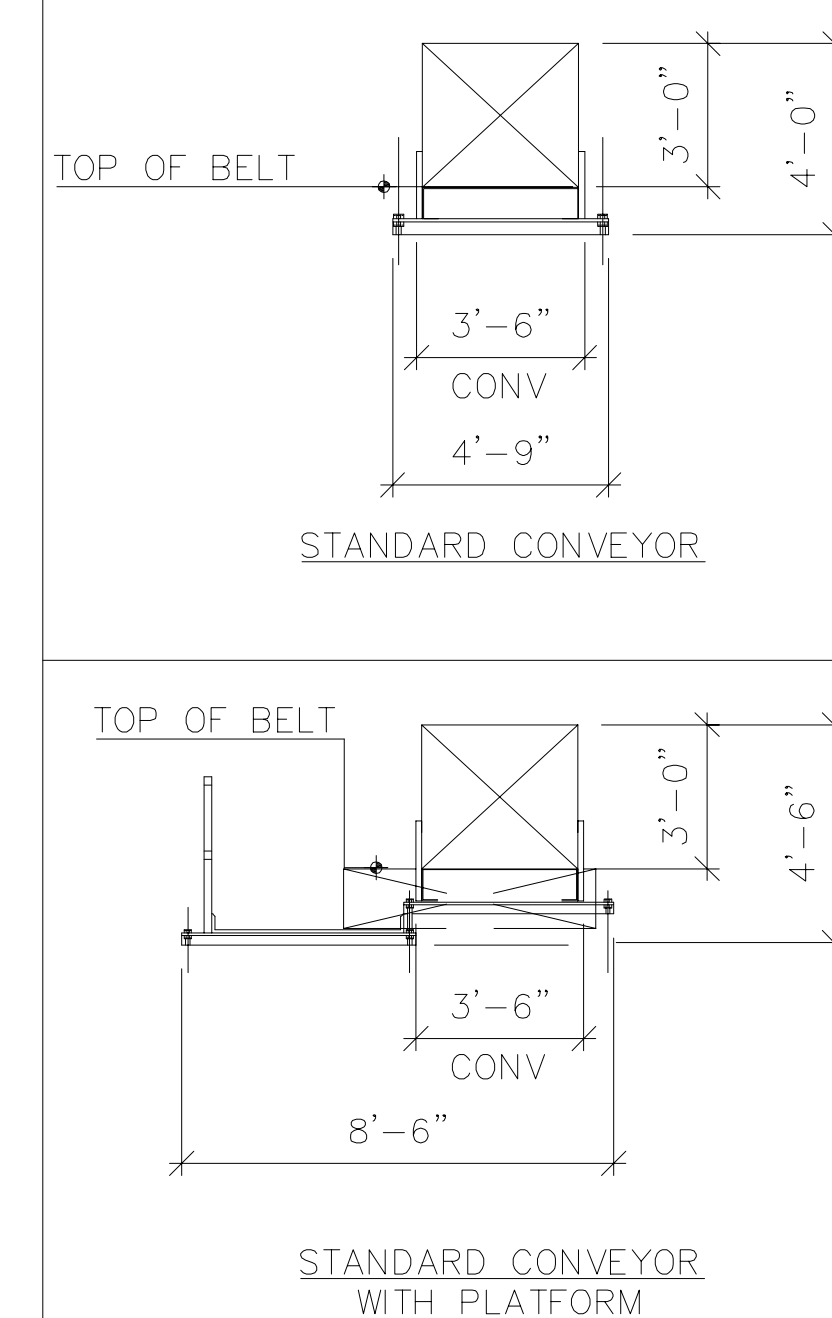

GENERAL NOTES

THE FOLLOWING, TOGETHER WITH THE PROJECT SPECIFICATIONS AND BHS DRAWINGS SHALL APPLY:

- A. CHECK AND FIELD VERIFY ALL BHS RELATED DIMENSIONS ON THE JOB SITE BEFORE PROCEEDING WITH WORK, AND BE RESPONSIBLE FOR THEIR ACCURACY. IF DISCREPANCIES ARE FOUND BETWEEN THE BHS DRAWINGS, SPECIFICATIONS AND FIELD CONDITIONS, THEY SHALL BE REPORTED TO THE OWNER'S REPRESENTATIVE.
- B. NO DIMENSIONS SHALL BE SCALED, DRAWINGS DIMENSIONS SHOWN SHALL BE USED.
- C. REFERENCE STRUCTURAL DRAWINGS FOR BEAM LOCATIONS.
- D. FOR ADDITIONAL BHS RIGHT-OF-WAY DETAILS SEE B12 SERIES.
- E. ALL TICKET COUNTERS AND BAG WELLS SHALL NOT BE BHS CONTRACTOR.
- F. BHS CONTRACTOR TO COORDINATE WITH ALL OTHER TRADES TO MAINTAIN BAGGAGE SYSTEM RIGHT-OF-WAY.
- G. ALL DIMENSIONS ARE FROM COLUMN CENTER LINE TO FACE OF CONVEYOR SIDE GUARD, UNLESS OTHERWISE NOTED.
- H. ALL OTHER TRADES TO MAINTAIN 3'-0" CLEAR RIGHT-OF-WAY FROM TOP OF BELT TO NEAREST OBSTRUCTION. HANGING OF ANY EQUIPMENT COMPONENTS MECHANICAL, ELECTRICAL, PLUMBING, HVAC, FROM THE CONVEYOR, CATWALK OR ASSOCIATED SUPPORTS IS NOT ALLOWED.
- I. ALL BHS RIGHT-OF-WAY SHALL TAKE PRECEDENCE OVER ALL OTHER BUILDING SERVICES (MECHANICAL DUCT WORK AND PIPES, ELECTRICAL CONDUIT, SECURITY CONDUIT, FIRE PROTECTION PIPING, PLUMBING PIPES, ETC.).
- J. ALL FINISHED FLOOR DIMENSIONS ARE TAKEN FROM THE HIGH POINT OF THE FINISHED FLOOR.

KEY PLAN

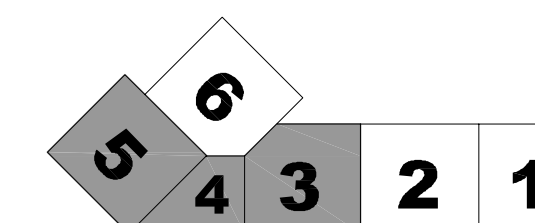

Portland International Jetport

1001 Westbrook Street
Portland, Maine 04102

Gensler

2020 K Street, NW
Suite 200
Washington, DC 20006
Telephone 202.721.5200
Facsimile 202.872.8557

BNP ASSOCIATES, INC.

PHONE: 203.792.3000
FAX: 203.792.4900
BNPHQ@BNPASSOCIATES.COM

101 EAST RIDGE OFFICE PARK
SUITE 103
DANBURY, CT 06810 USA

Issue	Date & Issue Description	By	Check
01	7/15/09	BNP	JWKS
02	9/15/09	BNP	JWKS
03	10/26/09	BNP	JWKS

Project Name
PJM Terminal Expansion

Project Number
09.6395.000
CAD File Name
B12.02.dwg
Description
BAGGAGE HANDLING SYSTEM - ATTACHMENT DETAILS

Scale

DATE OF ISSUE
7/15/09
ISSUED FOR PERMIT

Signature: *[Handwritten Signature]*

B12.02