

J SECTION - TC4 CONVEYOR
B09.03 1/4" = 1'-0"

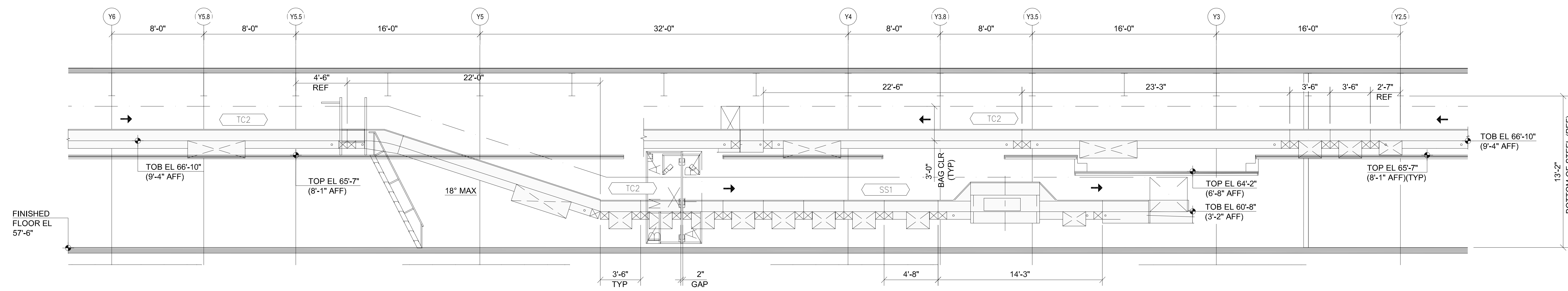

K SECTION - BAGGAGE MEASURING ARRAY-AUTOMATIC TAG READER
B09.03 1/4" = 1'-0"

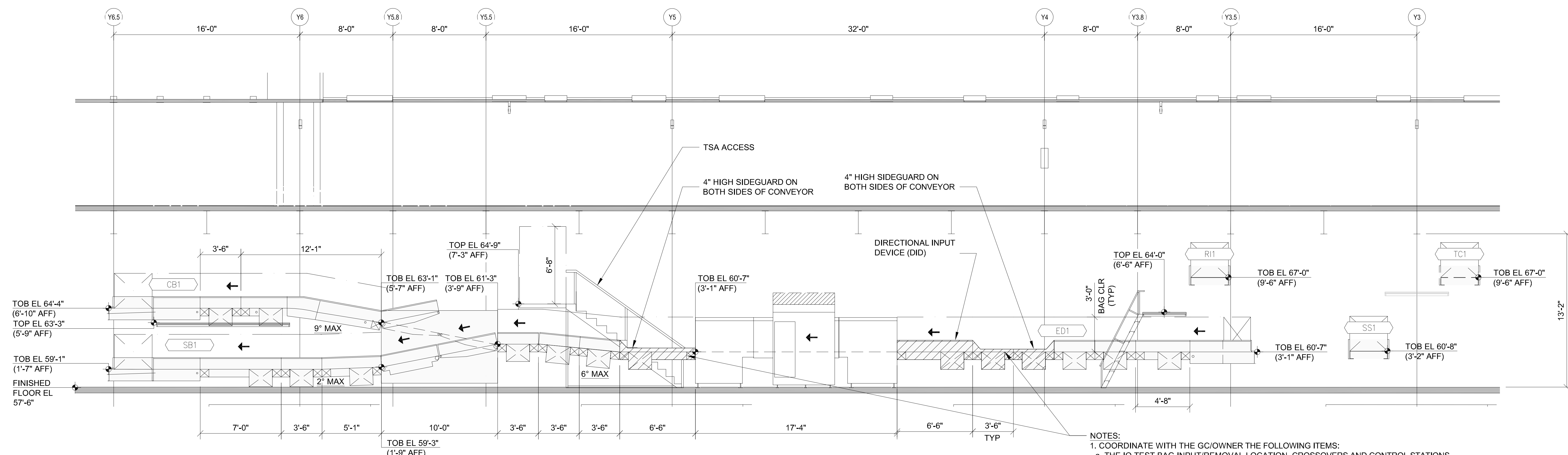

L SECTION - ED1 CONVEYORS
B09.03 1/4" = 1'-0"

- NOTES:**
- COORDINATE WITH THE GC/OWNER THE FOLLOWING ITEMS:
 - THE IQ TEST BAG INPUT/REMOVAL LOCATION, CROSSOVERS AND CONTROL STATIONS TO FACILITATE TSA AND O&M STAFF ACCESS.
 - THE IQ TEST BAG INPUT LOCATION UPSTREAM OF THE DIRECTIONAL INPUT DEVICE (DID).
 - THE LOCATION OF THE INSERT BAG/BYPASS CONTROL STATION WITH 4" HIGH SIDE GUARDS.
 - THE INSTALLATION OF "QUICK-DISCONNECT" ELECTRICAL DEVICES AND RELATED CONDUIT WITH EDS REMOVAL REQUIREMENTS AND OVERALL MECHANICAL INSTALLATION, TO MINIMIZE EDS REMOVAL/REPLACEMENT (AREAS INDICATED WITH HATCH).
 - THE CONVEYORS IMMEDIATELY UPSTREAM AND DOWNSTREAM OF THE EDS MACHINE (AREAS INDICATED WITH HATCH) SHALL BE EQUIPPED WITH CASTOR WHEELS (WITH SAFETY LOCKS) AND FLOOR PINS ON OPPOSITE SIDES OF THE RESPECTIVE CONVEYORS' FLOOR SUPPORT LEGS TO ASSIST IN THE REMOVAL/REPLACEMENT OF THE CONVEYOR SEGMENTS.
 - PROVIDE 4" HIGH SIDE GUARDS ON BOTH SIDES OF THE CONVEYOR SEGMENTS AT IQ TEST BAG INPUT/REMOVAL POINTS AS INDICATED.
 - ACTUAL LOCATION OF DID WILL BE DEPENDENT ON THE RESULT OF THE EDS PROTOTYPE, WHICH IS TO DEMONSTRATE (BENCHMARK) THE BEST POSSIBLE LOCATION FOR THE DID SECTION AND CONVEYOR SIDE GUARDS LOCATIONS/CONFIGURATION FOR THE EDS "IQTK" TEST BAG INPUT BELT. IN THIS REGARD PROVIDE DID WITH REMOVABLE HINGED SIDE GUARDS.
 - BE RESPONSIBLE FOR THE EXACT LOCATION/CENTERLINE OF EACH EDS MACHINE AS IT RELATES TO ITS RESPECTIVE CONVEYOR LINE.
 - BE RESPONSIBLE TO COORDINATE THE EDS MACHINE INSTALLATION PER THE MANUFACTURERS GUIDELINES.

SHEET NOTES

LEGEND

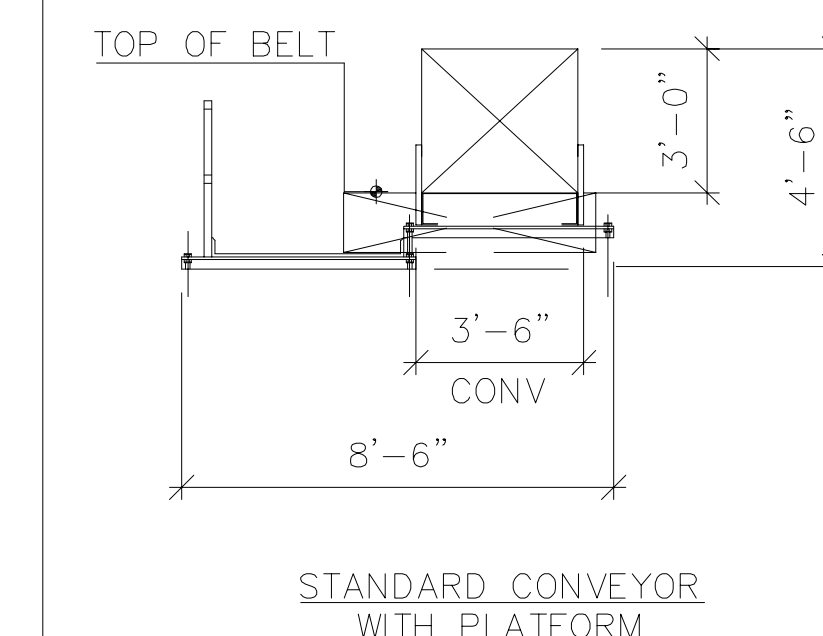
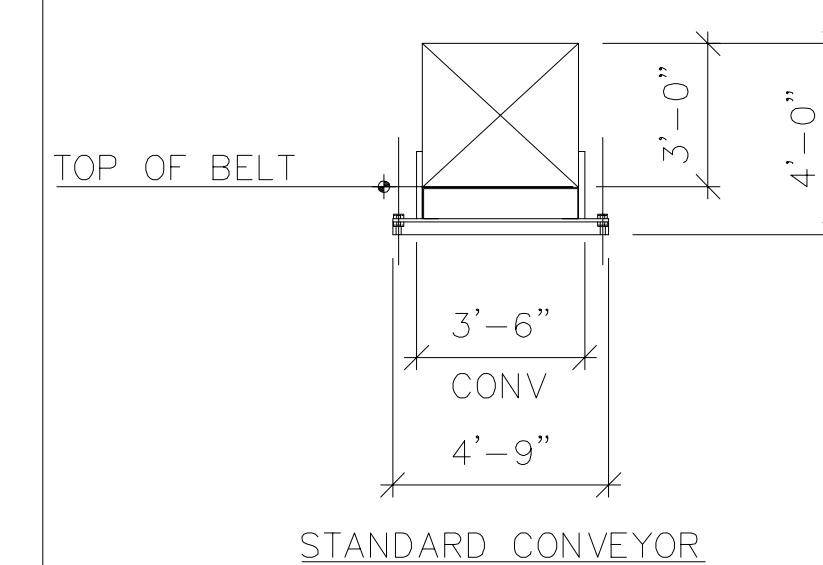

GENERAL NOTES

- THE FOLLOWING, TOGETHER WITH THE PROJECT SPECIFICATIONS AND BHS DRAWINGS SHALL APPLY:
- CHECK AND FIELD VERIFY ALL BHS RELATED DIMENSIONS ON THE JOB SITE BEFORE PROCEEDING WITH WORK, AND BE RESPONSIBLE FOR THEIR ACCURACY. IF DISCREPANCIES ARE FOUND BETWEEN THE BHS DRAWINGS, SPECIFICATIONS AND FIELD CONDITIONS, THEY SHALL BE REPORTED TO THE OWNER'S REPRESENTATIVE.
 - NO DIMENSIONS SHALL BE SCALED, DRAWINGS DIMENSIONS SHOWN SHALL BE USED.
 - REFERENCE STRUCTURAL DRAWINGS FOR BEAM LOCATIONS.
 - FOR ADDITIONAL BHS RIGHT-OF-WAY DETAILS SEE B12 SERIES.
 - ALL TICKET COUNTERS AND BAG WELLS SCALES NOT BY BHS CONTRACTOR.
 - BHS CONTRACTOR TO COORDINATE WITH ALL OTHER TRADES TO MAINTAIN BAGGAGE SYSTEM RIGHT-OF-WAY.
 - ALL DIMENSIONS ARE FROM COLUMN CENTER LINE TO FACE OF CONVEYOR SIDE GUARD, UNLESS OTHERWISE NOTED.
 - ALL OTHER TRADES TO MAINTAIN 3'-0" CLEAR RIGHT-OF-WAY FROM TOP OF BELT TO NEAREST OBSTRUCTION. HANGING OF ANY EQUIPMENT COMPONENTS MECHANICAL, ELECTRICAL, PLUMBING, HVAC... FROM THE CONVEYOR, CATWALK OR ASSOCIATED SUPPORTS IS NOT ALLOWED.
 - ALL BHS RIGHT-OF-WAY SHALL TAKE PRECEDENCE OVER ALL OTHER BUILDING SERVICES (MECHANICAL DUCT WORK AND PIPES, ELECTRICAL CONDUIT, SECURITY CONDUIT, FIRE PROTECTION PIPING, PLUMBING PIPES, ETC.).
 - ALL FINISHED FLOOR DIMENSIONS ARE TAKEN FROM THE HIGH POINT OF THE FINISHED FLOOR.

KEY PLAN

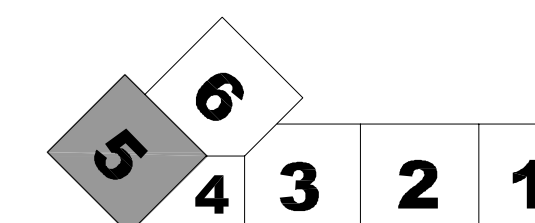

Portland International Jetport
1001 Westbrook Street
Portland, Maine 04102

Gensler

2020 K Street, NW
Suite 200
Washington, DC 20006
Telephone 202.721.5200
Facsimile 202.872.8557

BNP ASSOCIATES, INC.

PHONE: 203.792.3000
FAX: 203.792.4900
BNPHQ@BNPASSOCIATES.COM

101 EAST RIDGE OFFICE PARK
SUITE 103
DANBURY, CT 06810 USA

Issue	Date & Issue Description	By	Check
01	9/15/09	BNP	JWIKS
02	10/26/09	BNP	JWIKS

GENERAL NOTES

- THE FOLLOWING, TOGETHER WITH THE PROJECT SPECIFICATIONS AND BHS DRAWINGS SHALL APPLY:
- CHECK AND FIELD VERIFY ALL BHS RELATED DIMENSIONS ON THE JOB SITE BEFORE PROCEEDING WITH WORK, AND BE RESPONSIBLE FOR THEIR ACCURACY. IF DISCREPANCIES ARE FOUND BETWEEN THE BHS DRAWINGS, SPECIFICATIONS AND FIELD CONDITIONS, THEY SHALL BE REPORTED TO THE OWNER'S REPRESENTATIVE.
 - NO DIMENSIONS SHALL BE SCALED, DRAWINGS DIMENSIONS SHOWN SHALL BE USED.
 - REFERENCE STRUCTURAL DRAWINGS FOR BEAM LOCATIONS.
 - FOR ADDITIONAL BHS RIGHT-OF-WAY DETAILS SEE B12 SERIES.
 - ALL TICKET COUNTERS AND BAG WELLS SCALES NOT BY BHS CONTRACTOR.
 - BHS CONTRACTOR TO COORDINATE WITH ALL OTHER TRADES TO MAINTAIN BAGGAGE SYSTEM RIGHT-OF-WAY.
 - ALL DIMENSIONS ARE FROM COLUMN CENTER LINE TO FACE OF CONVEYOR SIDE GUARD, UNLESS OTHERWISE NOTED.
 - ALL OTHER TRADES TO MAINTAIN 3'-0" CLEAR RIGHT-OF-WAY FROM TOP OF BELT TO NEAREST OBSTRUCTION. HANGING OF ANY EQUIPMENT COMPONENTS MECHANICAL, ELECTRICAL, PLUMBING, HVAC... FROM THE CONVEYOR, CATWALK OR ASSOCIATED SUPPORTS IS NOT ALLOWED.
 - ALL BHS RIGHT-OF-WAY SHALL TAKE PRECEDENCE OVER ALL OTHER BUILDING SERVICES (MECHANICAL DUCT WORK AND PIPES, ELECTRICAL CONDUIT, SECURITY CONDUIT, FIRE PROTECTION PIPING, PLUMBING PIPES, ETC.).
 - ALL FINISHED FLOOR DIMENSIONS ARE TAKEN FROM THE HIGH POINT OF THE FINISHED FLOOR.

Project Name
PJM Terminal Expansion

Project Number
09.6395.000
CAD File Name
B09.03.dwg
Description
SECTIONS-JL

B09.03

©2009 Gensler