

**SHEET NOTES**

**LEGEND**

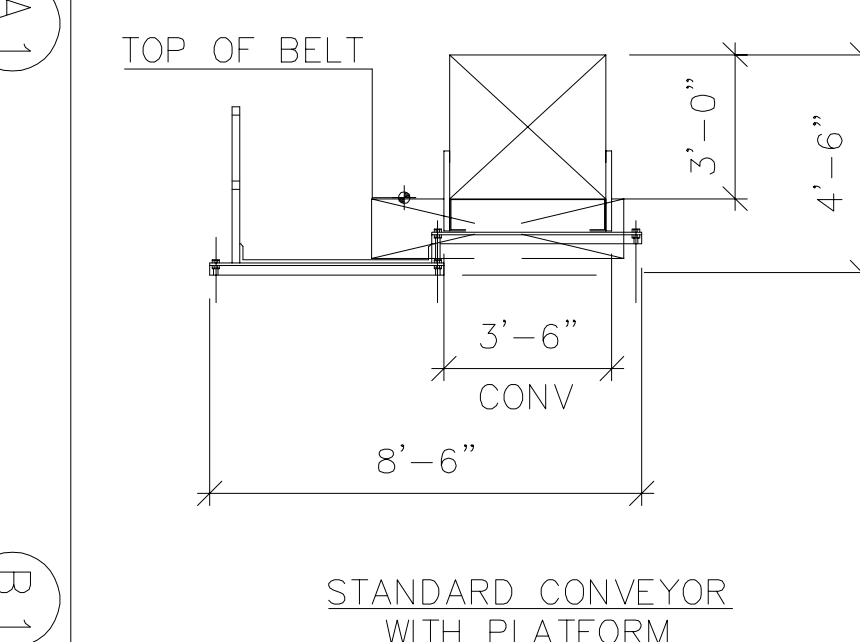
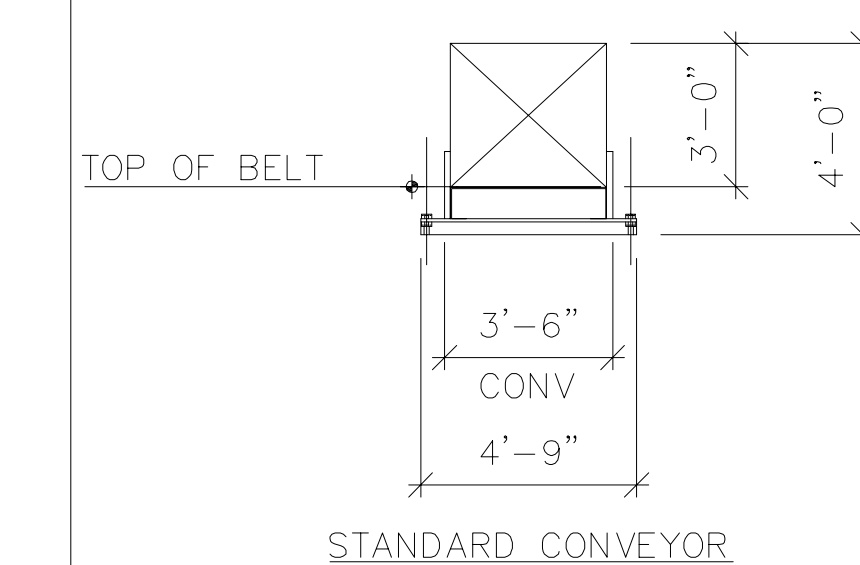

**GENERAL NOTES**

THE FOLLOWING, TOGETHER WITH THE PROJECT SPECIFICATIONS AND BHS DRAWINGS SHALL APPLY:

- A. CHECK AND FIELD VERIFY ALL BHS RELATED DIMENSIONS ON THE JOB SITE BEFORE PROCEEDING WITH WORK, AND BE RESPONSIBLE FOR THEIR ACCURACY. IF DISCREPANCIES ARE FOUND BETWEEN THE BHS DRAWINGS, SPECIFICATIONS AND FIELD CONDITIONS, THEY SHALL BE REPORTED TO THE OWNER'S REPRESENTATIVE.
- B. NO DIMENSIONS SHALL BE SCALED, DRAWINGS DIMENSIONS SHOWN SHALL BE USED.
- C. REFERENCE STRUCTURAL DRAWINGS FOR BEAM LOCATIONS.
- D. FOR ADDITIONAL BHS RIGHT-OF-WAY DETAILS SEE B12 SERIES.
- E. ALL TICKET COUNTERS AND BAG WELLS SHALL NOT BE BHS CONTRACTOR.
- F. BHS CONTRACTOR TO COORDINATE WITH ALL OTHER TRADES TO MAINTAIN BAGGAGE SYSTEM RIGHT-OF-WAY.
- G. ALL DIMENSIONS ARE FROM COLUMN CENTER LINE TO FACE OF CONVEYOR SIDE GUARD, UNLESS OTHERWISE NOTED.
- H. ALL OTHER TRADES TO MAINTAIN 3'-0" CLEAR RIGHT-OF-WAY FROM TOP OF BELT TO NEAREST OBSTRUCTION. HANGING OF ANY EQUIPMENT COMPONENTS MECHANICAL, ELECTRICAL, PLUMBING, HVAC, FROM THE CONVEYOR, CATWALK OR ASSOCIATED SUPPORTS IS NOT ALLOWED.
- I. ALL BHS RIGHT-OF-WAY SHALL TAKE PRECEDENCE OVER ALL OTHER BUILDING SERVICES (MECHANICAL DUCT WORK AND PIPES, ELECTRICAL CONDUIT, SECURITY CONDUIT, FIRE PROTECTION PIPING, PLUMBING PIPES, ETC.)
- J. ALL FINISHED FLOOR DIMENSIONS ARE TAKEN FROM THE HIGH POINT OF THE FINISHED FLOOR.

**KEY PLAN**

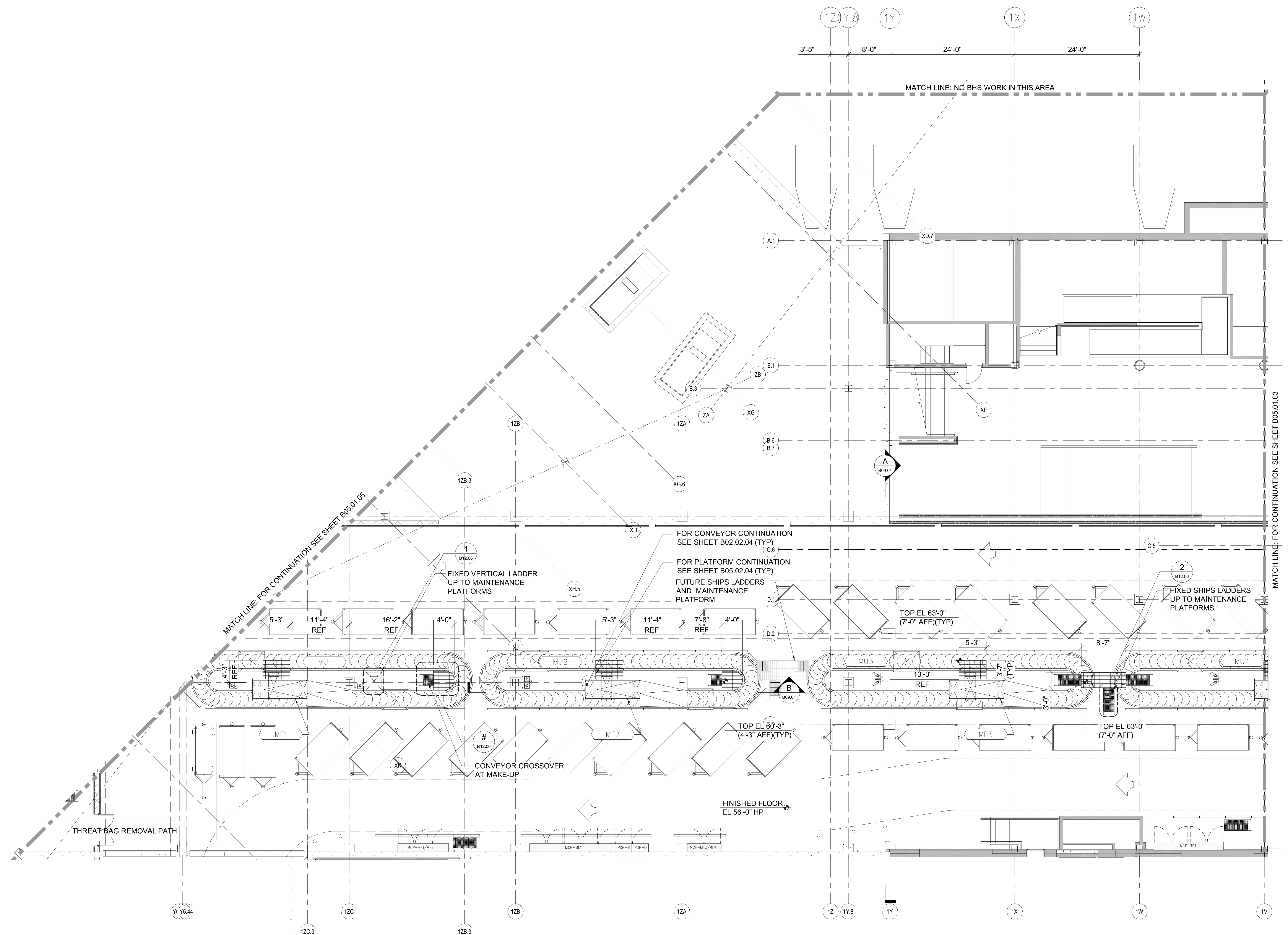
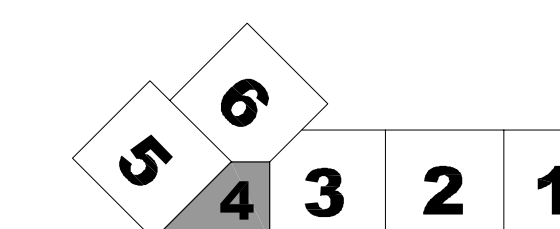

Issue Date & Issue Description By Check

01	7/15/09	ISSUED FOR TSA 30% SUBMITTAL	BNP	JWKS
02	9/15/09	ISSUED FOR TSA 70% SUBMITTAL	BNP	JWKS
03	10/26/09	ISSUED FOR PERMIT	BNP	JWKS

Signature: [Handwritten Signature]

Project Name: PWM Terminal Expansion

Project Number: 09.6395.000  
CAD File Name: B05.01.04.dwg  
Description: BAGGAGE HANDLING PLAN - PLATFORM - LEVEL 1 - ZONE 4

Scale: REF North