

SHEET NOTES

LEGEND

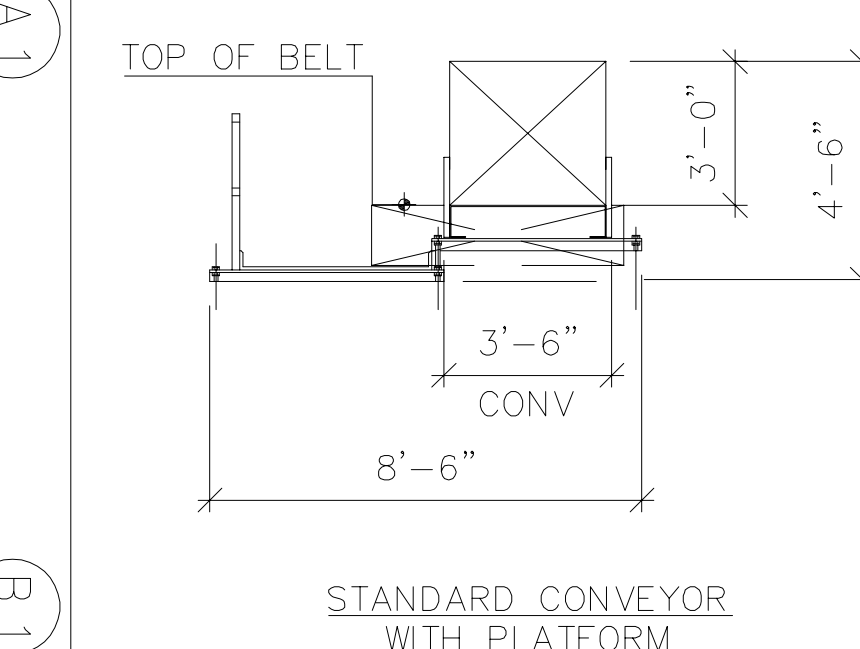
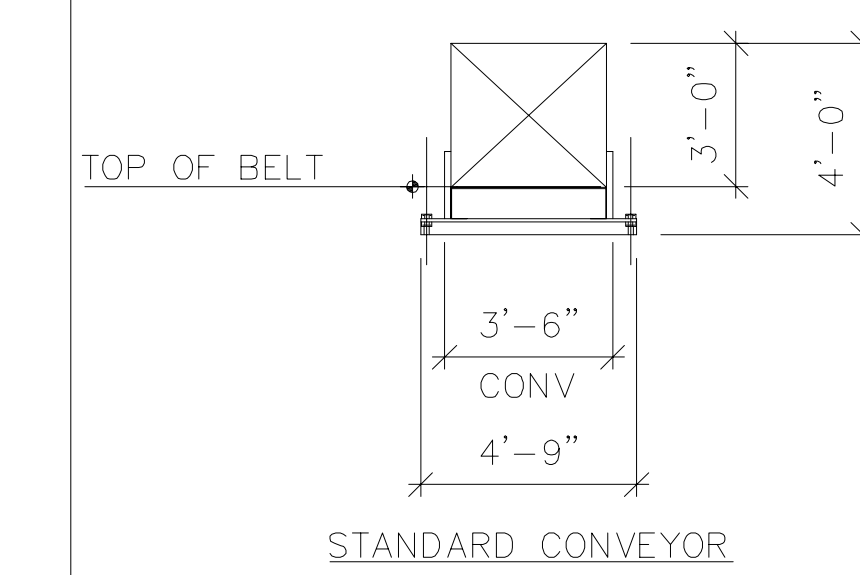

GENERAL NOTES

THE FOLLOWING, TOGETHER WITH THE PROJECT SPECIFICATIONS AND BHS DRAWINGS SHALL APPLY:

A. CHECK AND FIELD VERIFY ALL BHS RELATED DIMENSIONS ON THE JOB SITE BEFORE PROCEEDING WITH WORK, AND BE RESPONSIBLE FOR THEIR ACCURACY. IF DISCREPANCIES ARE FOUND BETWEEN THE BHS DRAWINGS, SPECIFICATIONS AND FIELD CONDITIONS, THEY SHALL BE REPORTED TO THE OWNER'S REPRESENTATIVE.

B. NO DIMENSIONS SHALL BE SCALED, DRAWINGS DIMENSIONS SHOWN SHALL BE USED.

C. REFERENCE STRUCTURAL DRAWINGS FOR BEAM LOCATIONS.

D. FOR ADDITIONAL BHS RIGHT-OF-WAY DETAILS SEE B12 SERIES.

E. ALL TICKET COUNTERS AND BAG WELLS SHALL NOT BE BHS CONTRACTOR.

F. BHS CONTRACTOR TO COORDINATE WITH ALL OTHER TRADES TO MAINTAIN BAGGAGE SYSTEM RIGHT-OF-WAY.

G. ALL DIMENSIONS ARE FROM COLUMN CENTER LINE TO FACE OF CONVEYOR SIDE GUARD, UNLESS OTHERWISE NOTED.

H. ALL OTHER TRADES TO MAINTAIN 3'-0" CLEAR RIGHT-OF-WAY FROM TOP OF BELT TO NEAREST OBSTRUCTION. HANGING OF ANY EQUIPMENT COMPONENTS MECHANICAL, ELECTRICAL, PLUMBING, HVAC, FROM THE CONVEYOR, CATWALK OR ASSOCIATED SUPPORTS IS NOT ALLOWED.

I. ALL BHS RIGHT-OF-WAY SHALL TAKE PRECEDENCE OVER ALL OTHER BUILDING SERVICES (MECHANICAL DUCT WORK AND PIPES, ELECTRICAL CONDUIT, SECURITY CONDUIT, FIRE PROTECTION PIPING, PLUMBING PIPES, ETC.)

J. ALL FINISHED FLOOR DIMENSIONS ARE TAKEN FROM THE HIGH POINT OF THE FINISHED FLOOR.

KEY PLAN

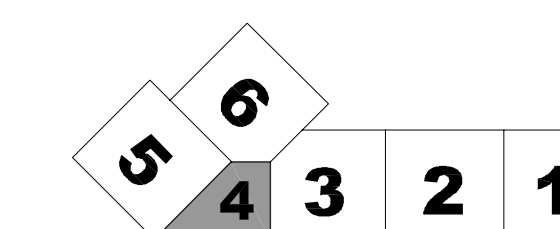

POWER SOURCE	FLA
B	NORMAL POWER 600
D	EMERGENCY POWER 60

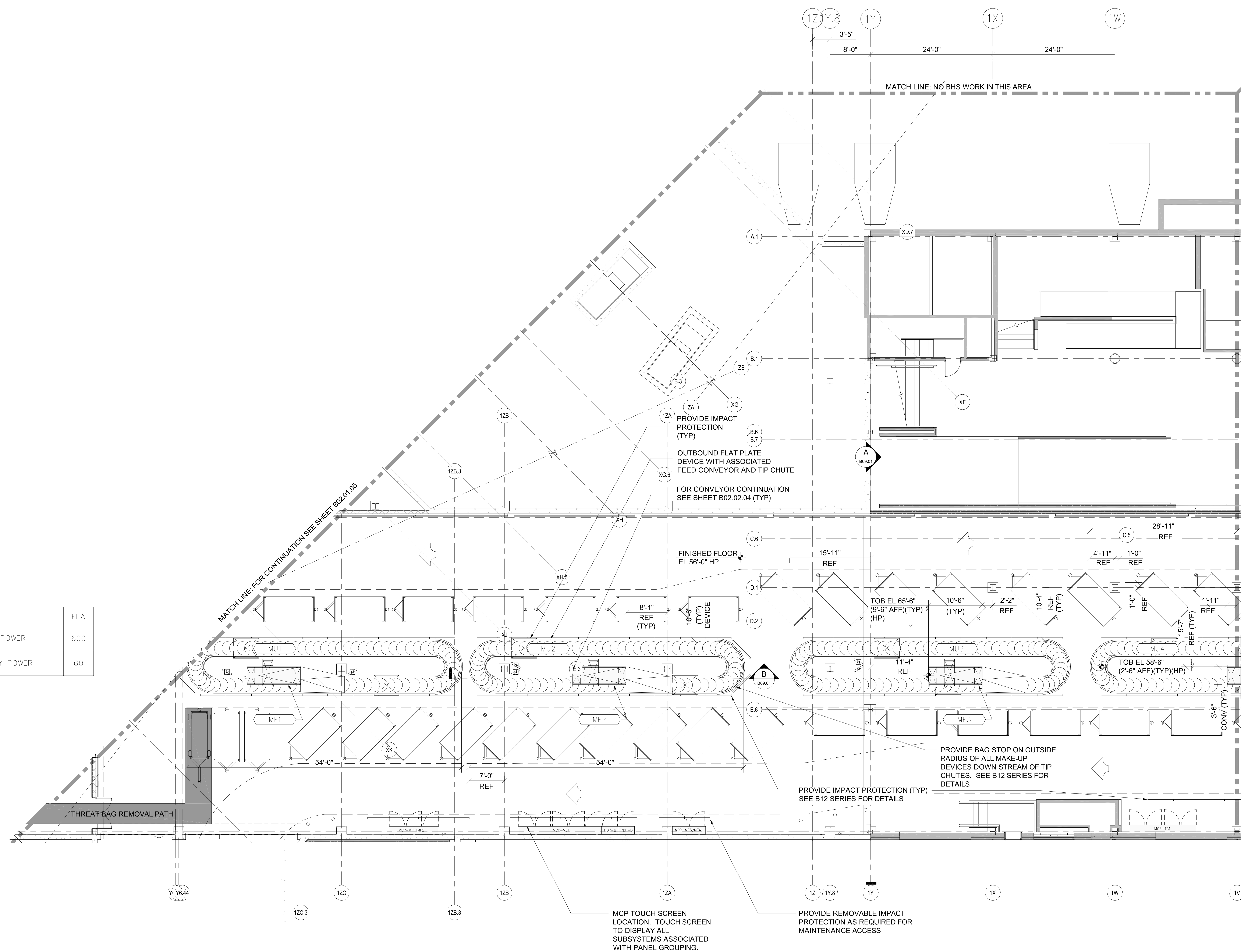

Issue	Date & Issue Description	By	Check
01	7/15/09	BNP	JW/KS
02	9/15/09	BNP	JW/KS
03	10/26/09	BNP	JW/KS

THE FOLLOWING ARE THE ISSUES FROM THE PREVIOUS SUBMITTAL:

Issue	Date & Issue Description	By	Check
01	7/15/09	BNP	JW/KS
02	9/15/09	BNP	JW/KS
03	10/26/09	BNP	JW/KS

See Signature

 John Whitehead
 Professional Engineer
 State of Maine
 No. 11838

Project Name
PJM Terminal Expansion

Project Number
09.6395.000

CAD File Name
B02.01.04.dwg

Description
BAGGAGE HANDLING PLAN - LEVEL 1 - ZONE 4

Scale