

TRANSITION@CONC/EXISTING CERAMIC 1
SCALE: 12" = 1'-0"

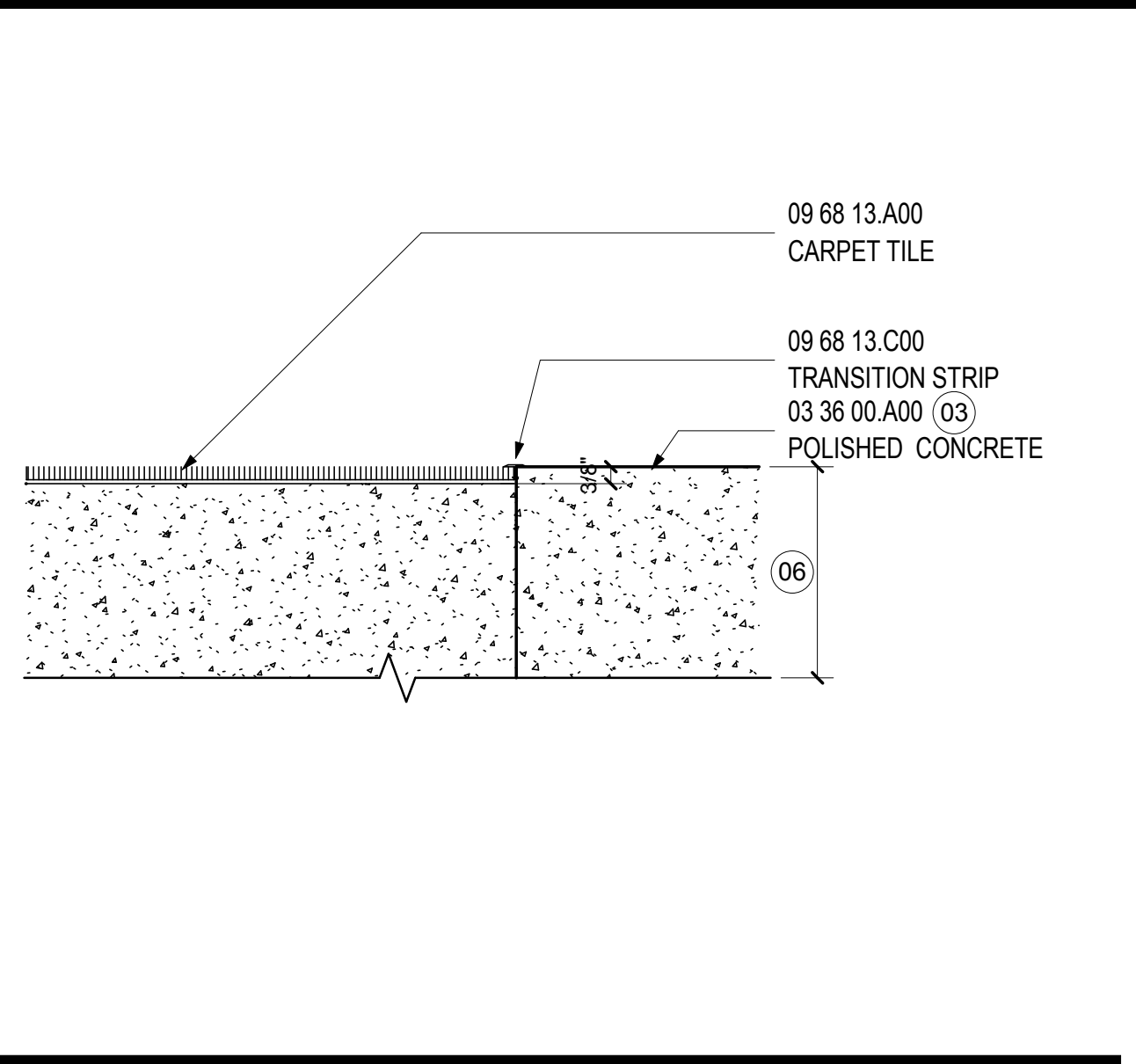

TRANSITION @ HOLDRM/ CONCOURSE 6
SCALE: 3" = 1'-0"

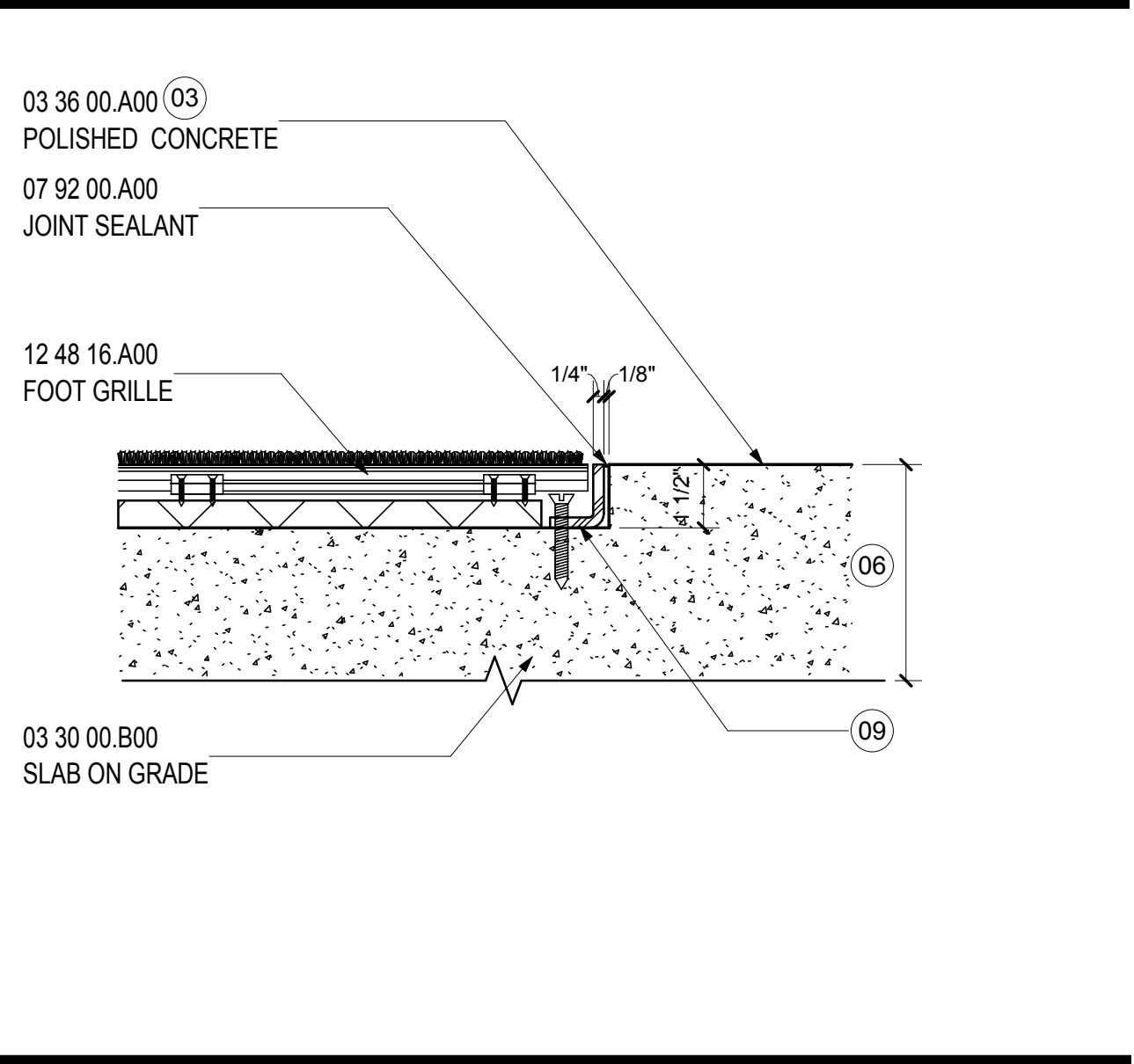

WALK OFF MAT TRANSITION 1
SCALE: 3" = 1'-0"

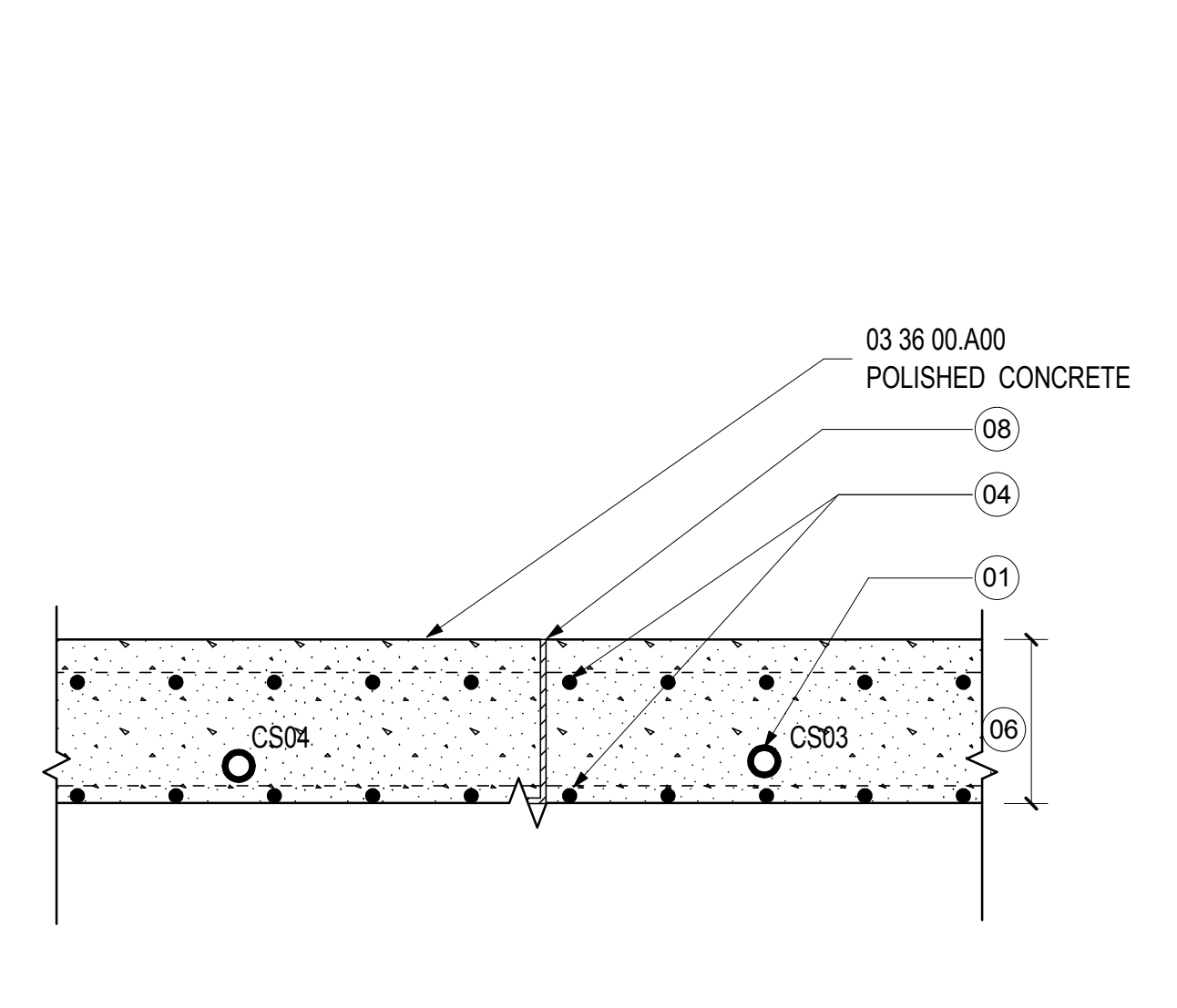

CONCRETE/ CONCRETE TRANSITION 7
SCALE: 3" = 1'-0"

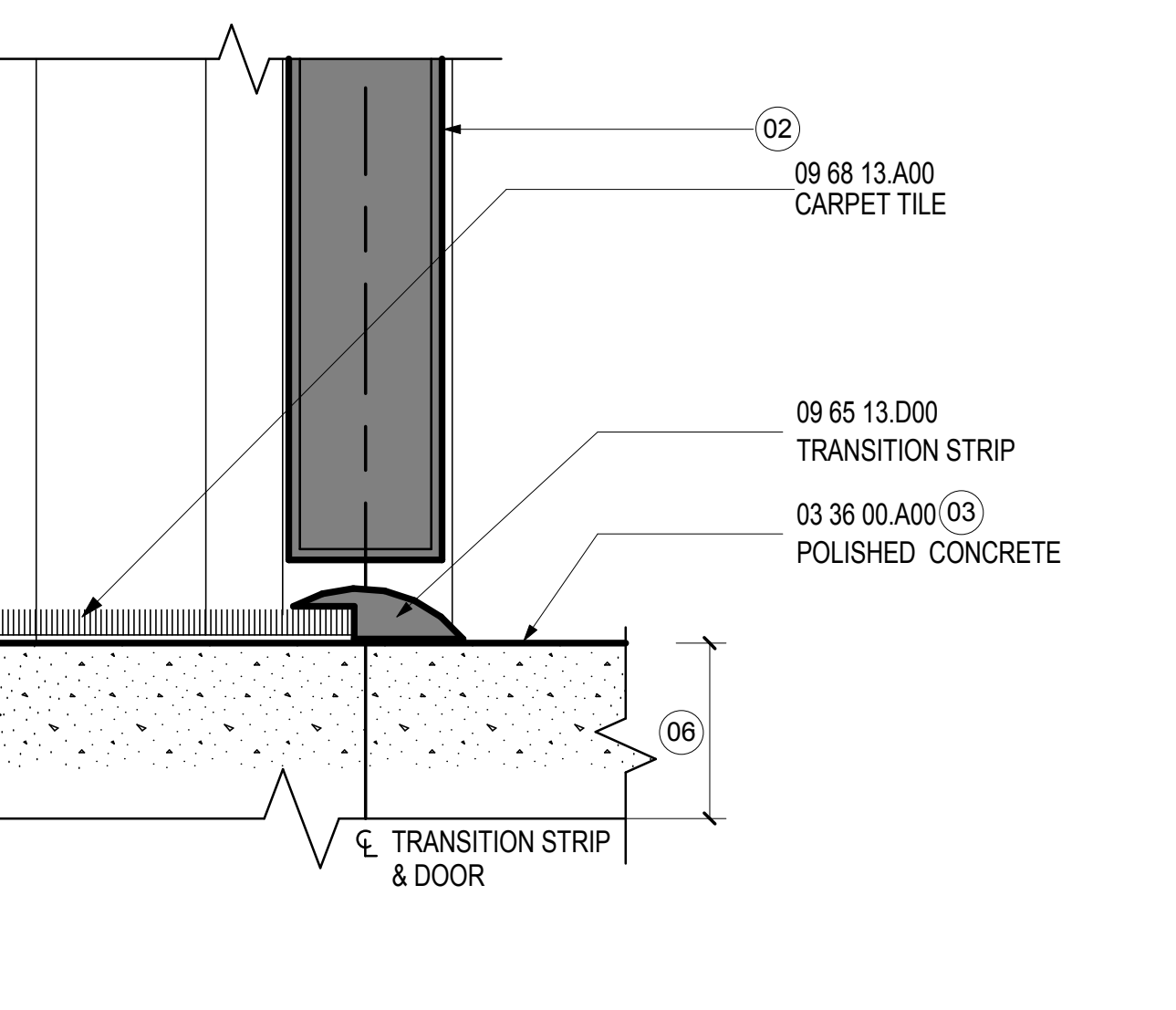

TRANSITION @ CARPET/CONCRETE 2
SCALE: 6" = 1'-0"

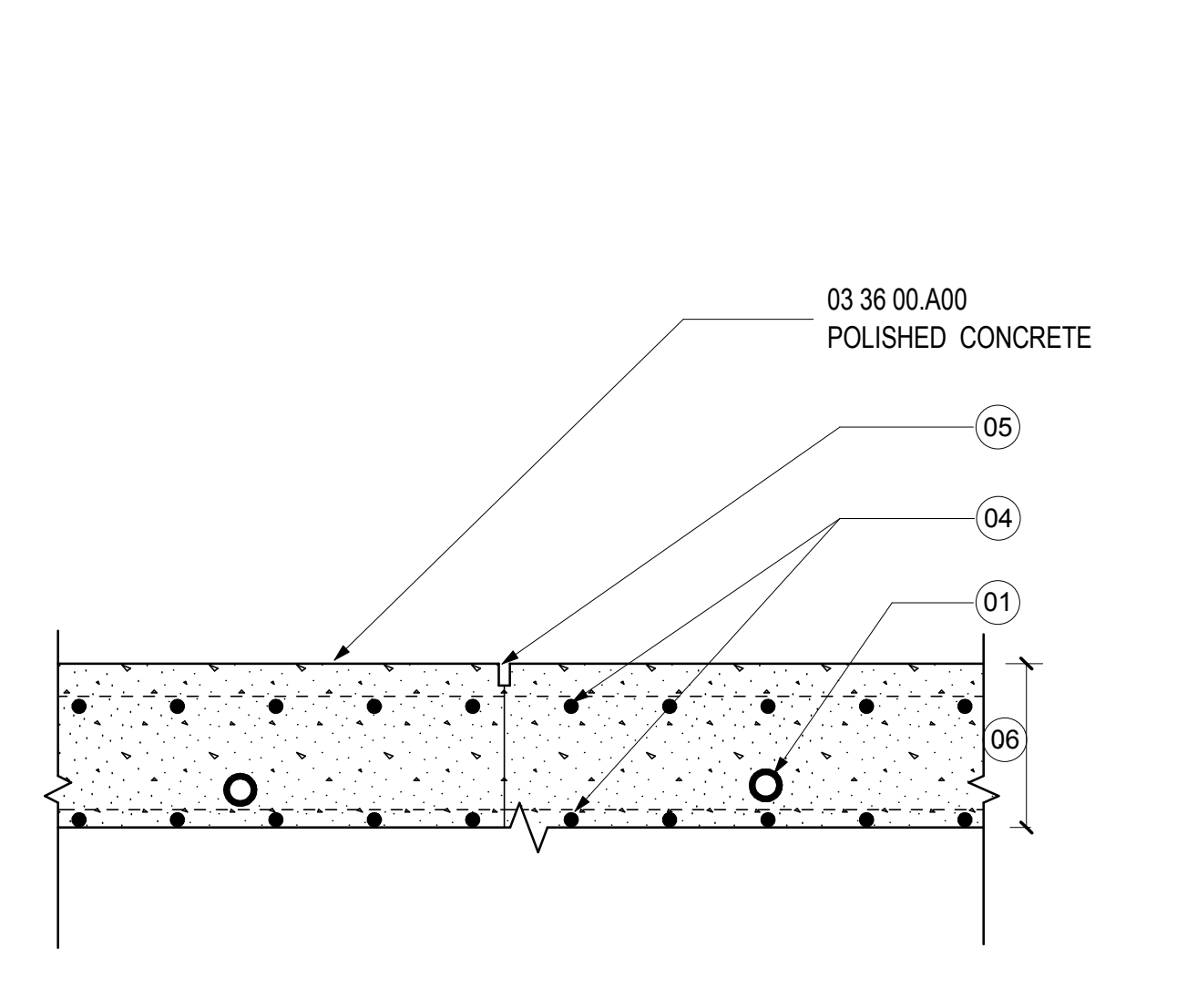

SOFF CUT JOINT 8
SCALE: 3" = 1'-0"

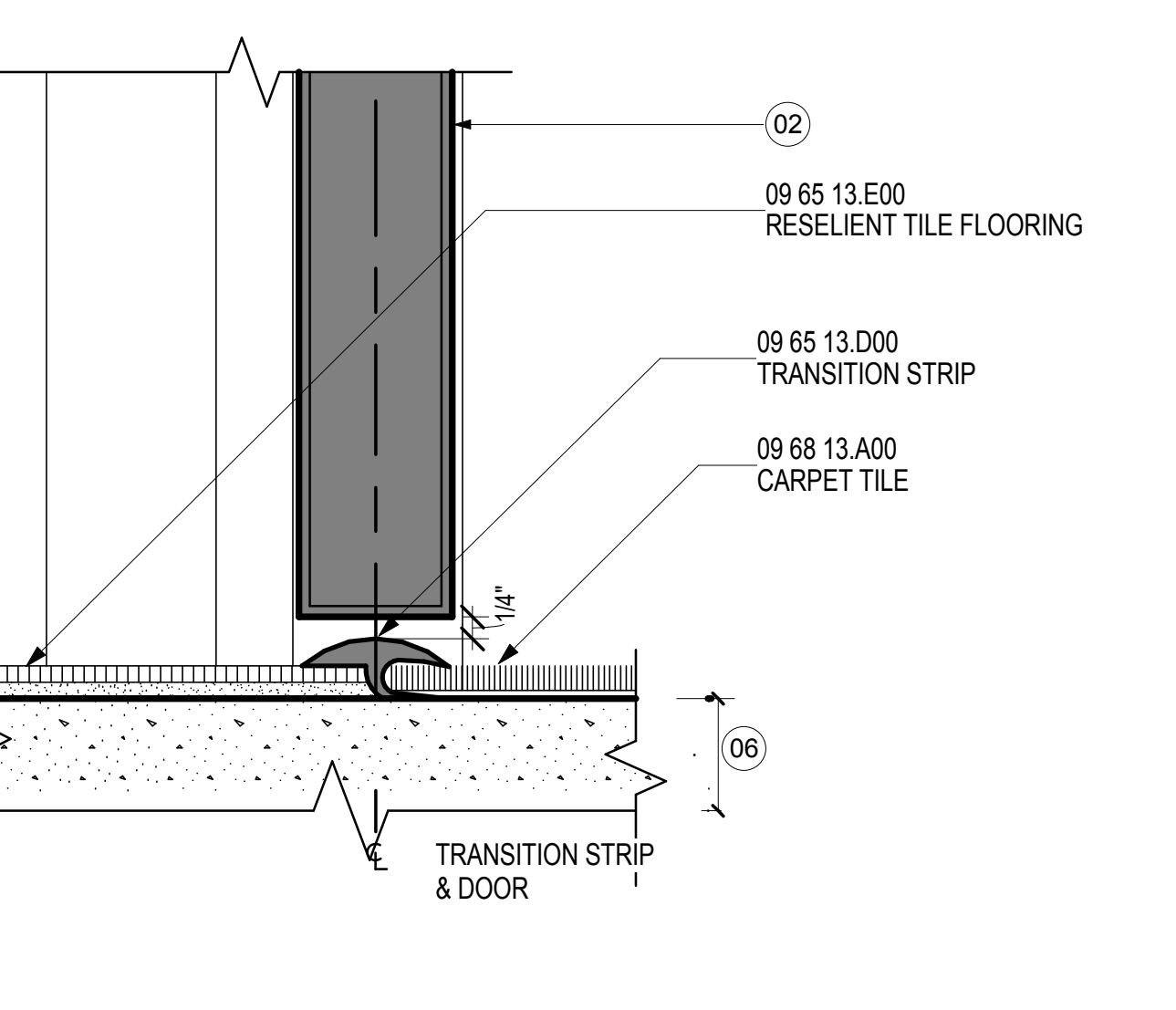

TRANSITION @ RESILIENT TILE/CARPET 3
SCALE: 6" = 1'-0"

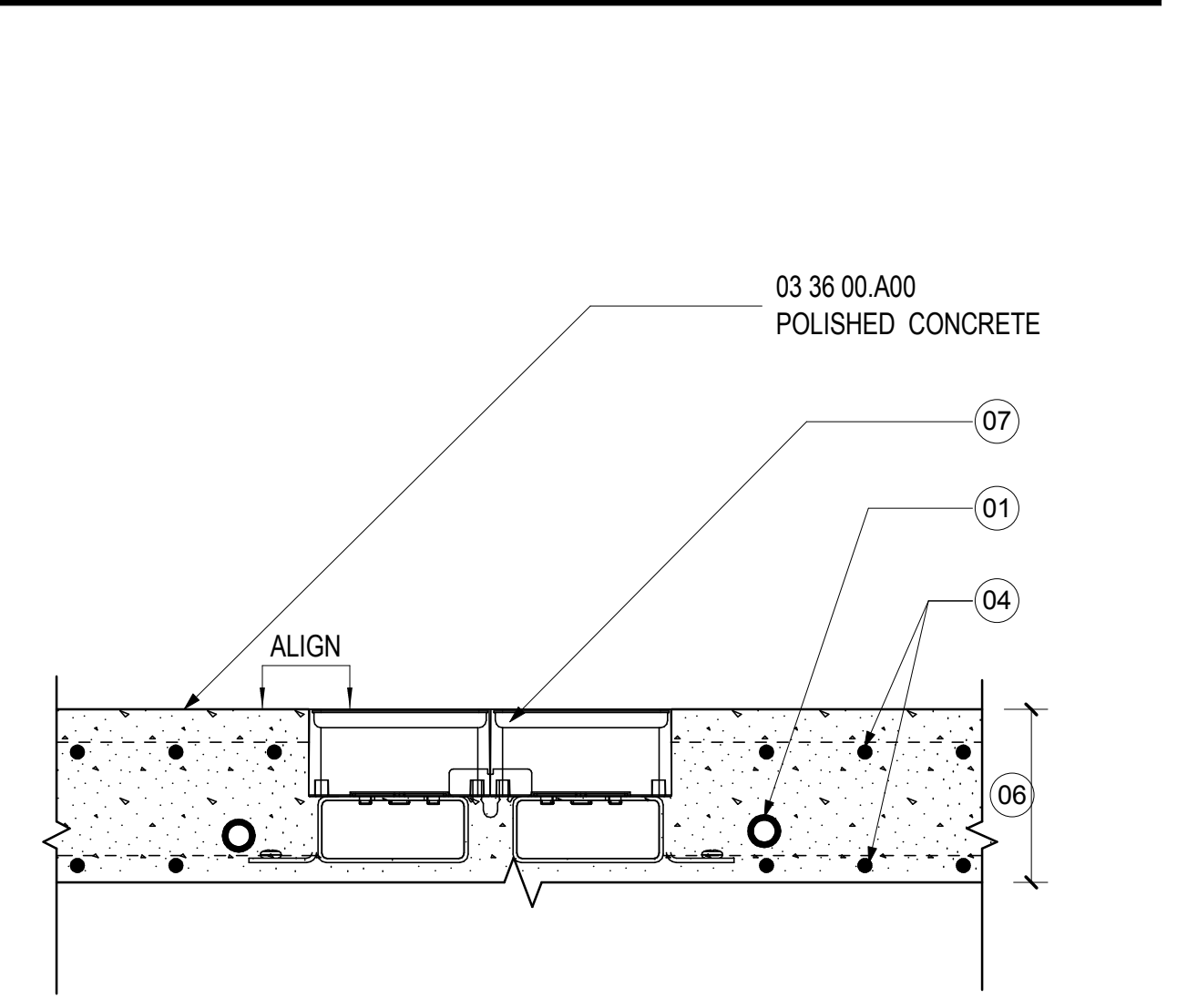

RACEWAY DETAIL 9
SCALE: 3" = 1'-0"

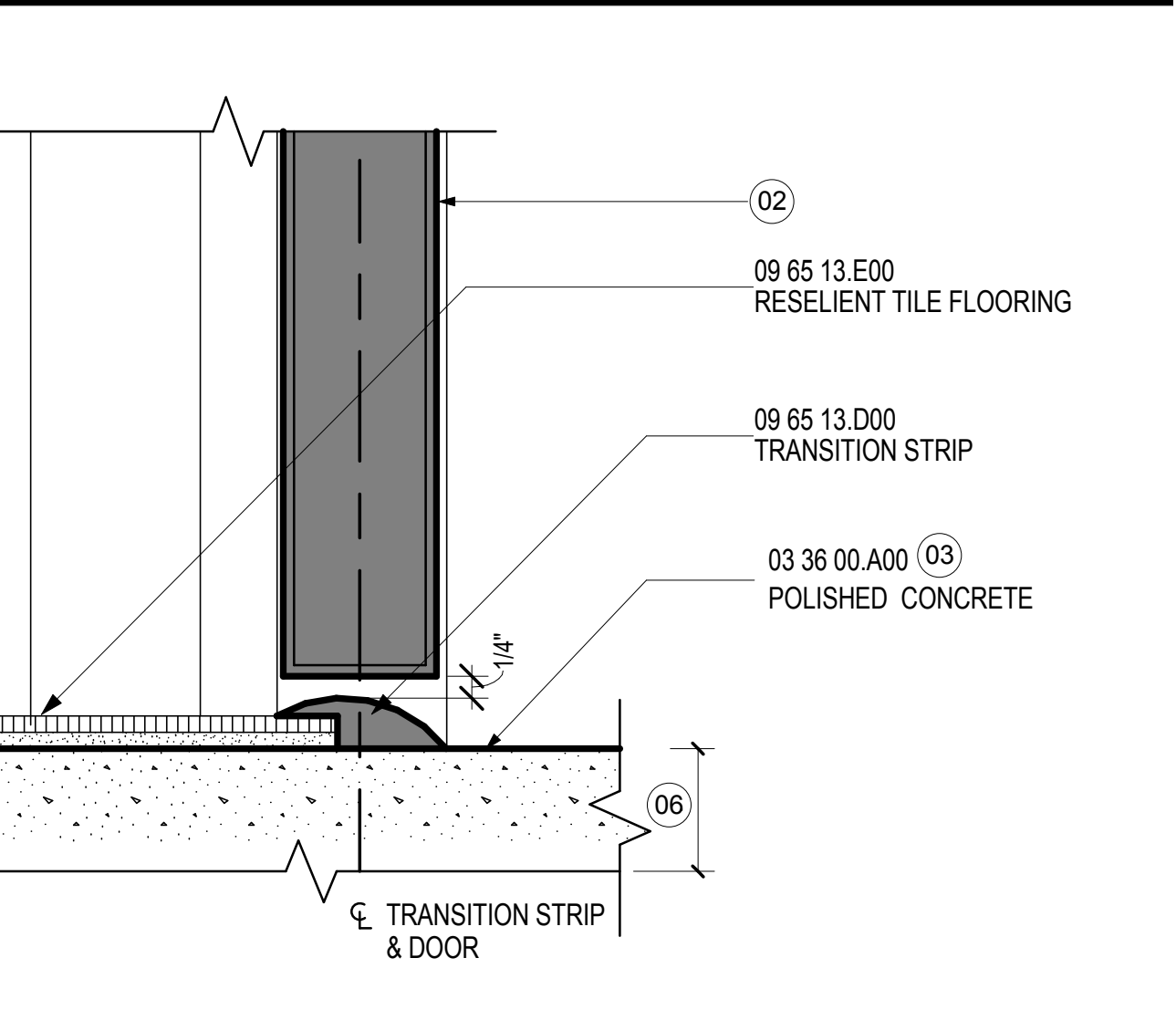

TRANSITION @ RESIL TILE/CONCRETE 4
SCALE: 6" = 1'-0"

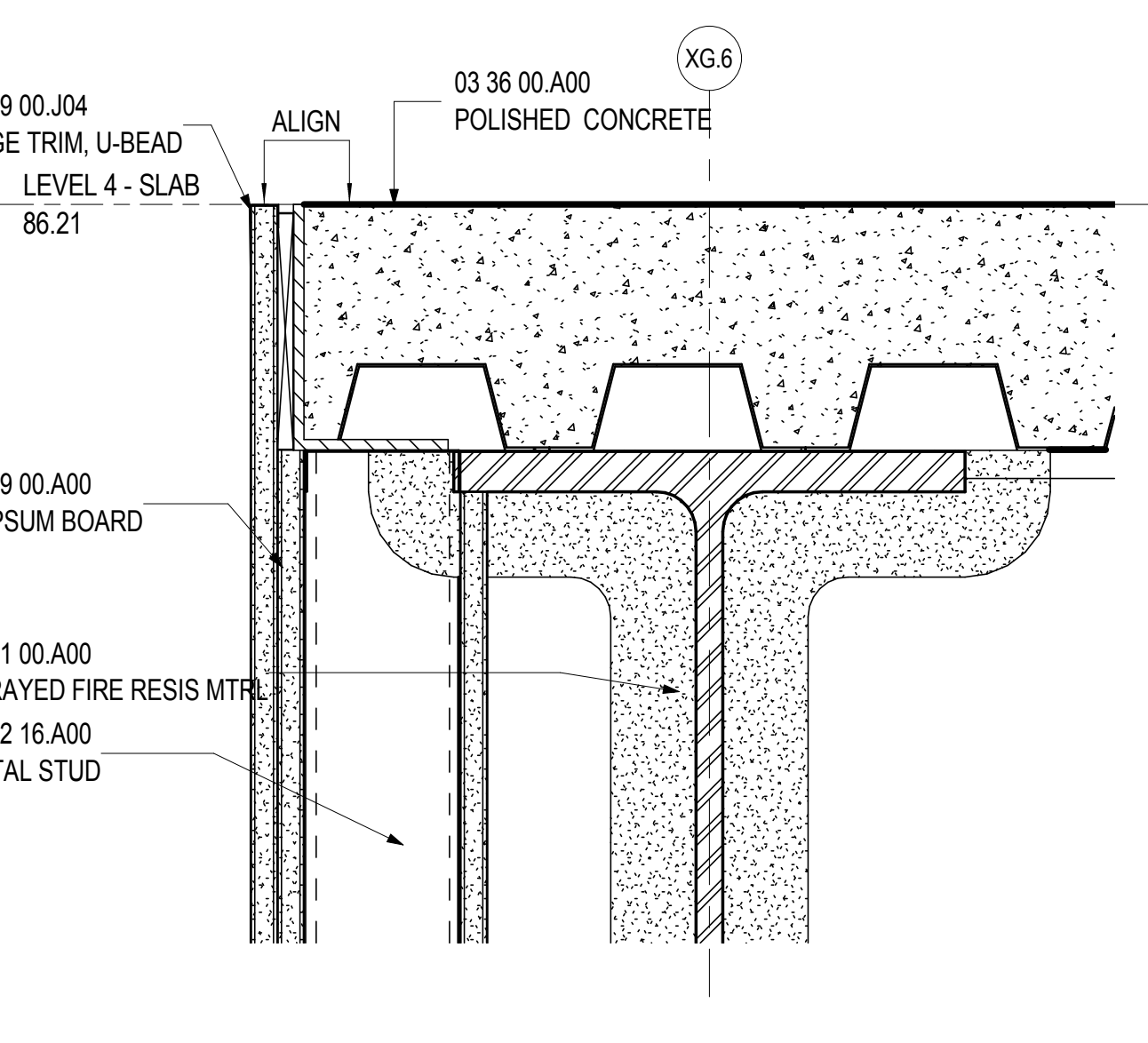

DETAIL @ SLAB EDGE 10
SCALE: 3" = 1'-0"

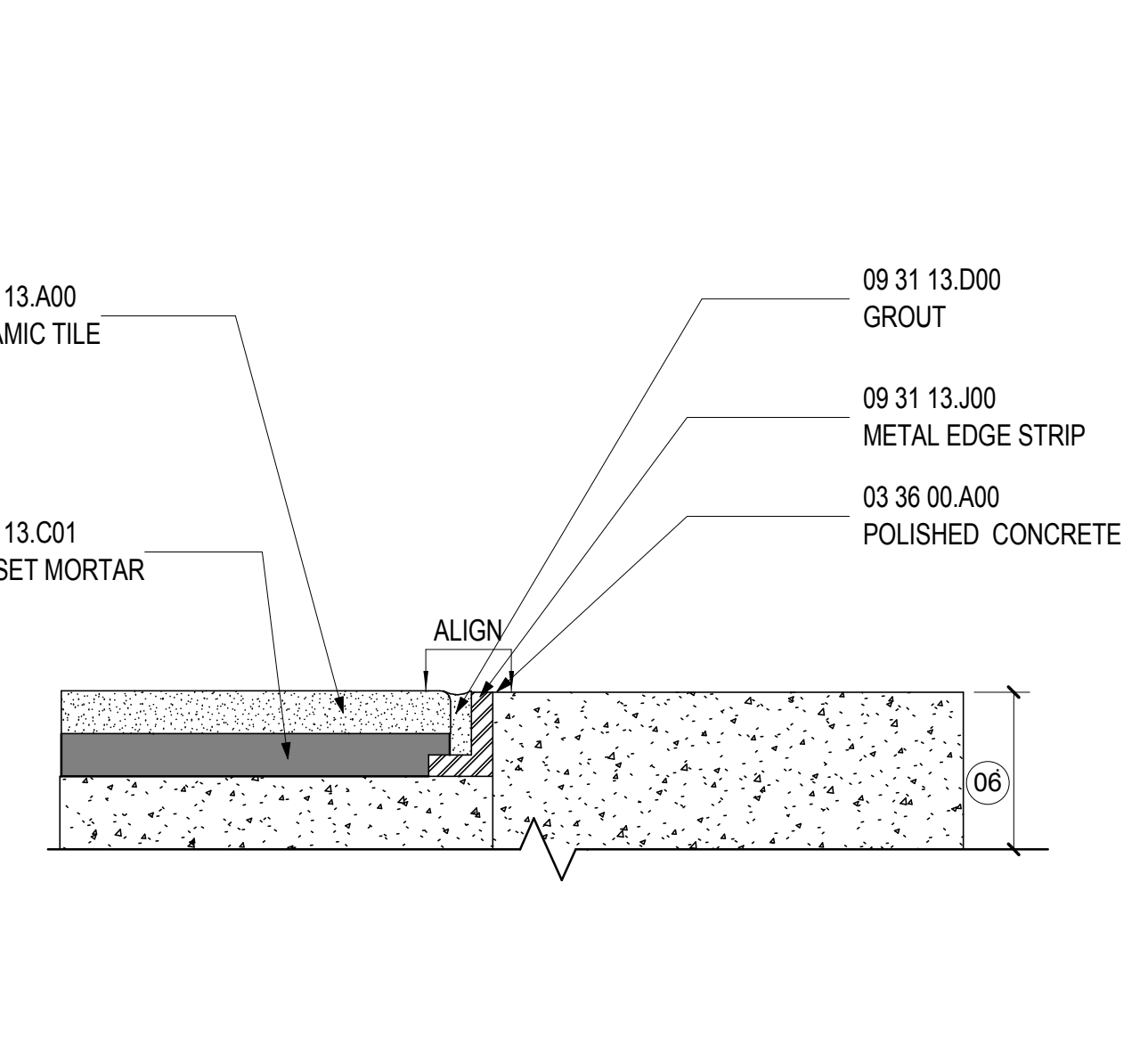

TRANSITION@CONCRETE/CERAMIC TILE 5
SCALE: 12" = 1'-0"

SHEET NOTES

- 01 RE: MECHANICAL DRAWINGS AND STRUCTURAL DRAWINGS TO COORDINATE PEX TUBE LOCATIONS AND FOR ADDITIONAL INFORMATION WHEN NOTED
- 02 SCHEDULED DOOR AND FRAME ASSEMBLY. WHEN NOTED
- 03 FINISHED CONCRETE SLAB
- 04 RE: MECHANICAL DRAWINGS AND STRUCTURAL DRAWINGS FOR COORDINATION OF W.W.R. LOCATIONS AND ADDITIONAL INFORMATION
- 05 1/2" DEEP SOFF CUT JOINT
- 06 FOR SLAB DEPTH RE: STRUCTURAL DRAWINGS FOR ADDITIONAL INFORMATION
- 07 CONDUIT RACEWAY. RE: SPECIFICATIONS AND PROJECT MANUAL FOR ADDITIONAL INFORMATION. RE: ELECTRICAL DRAWINGS FOR POWER REQUIREMENTS.
- 08 1/8" ZINC DIVIDER STRIP
- 09 1/4" ZINC DIVIDER ANGLE
- 10 RE: DETAIL 11/A10.03 FOR ADDITIONAL INFORMATION AT RAMP AT EXISTING TERMINAL

Portland International Jetport
1001 Westbrook Street
Portland, Maine 04102

Gensler
2020 K Street, Northwest
Suite 200
Washington DC 20006
Telephone 202.721.5200
Facsimile 202.872.8587

Issue	Date & Issue Description	By	Check
01	01/21/09		
02	95% CONSTRUCTION DOCUMENTS		
02	10/26/09		
	ISSUED FOR PERMIT		

Seal/Signature

Project Name
PWM Terminal Enhancement

Project Number
09 6395 000

Description
FINISH TRANSITION DETAILS

Scale
As indicated

A12.76

© 2009 Gensler