

WALL TYPE D.1 - SECTION

SCALE: 3/8" = 1'-0"

A09.51

4

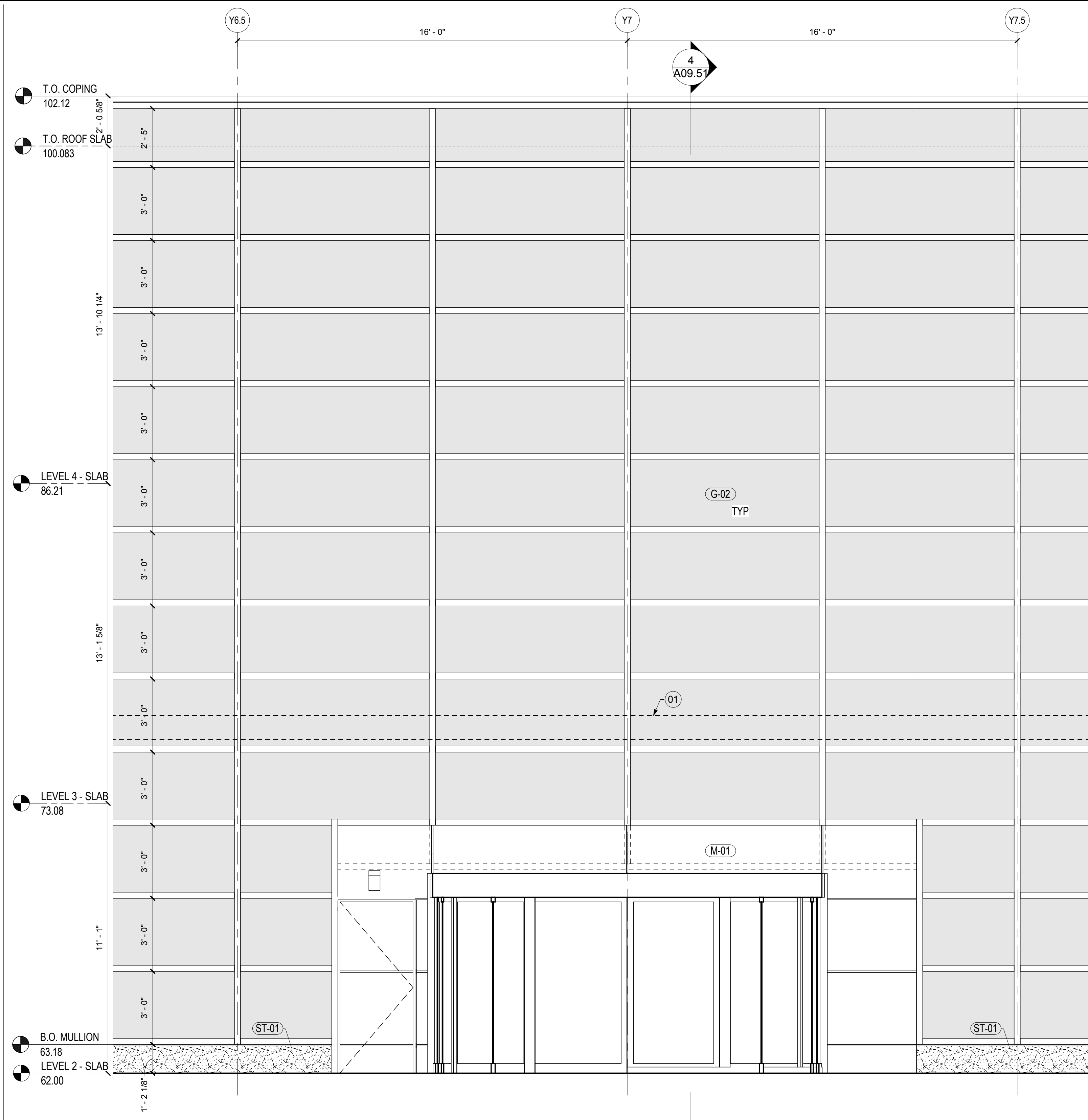

WALL TYPE D.1 - ELEVATION

SCALE: 3/8" = 1'-0"

A09.03

1

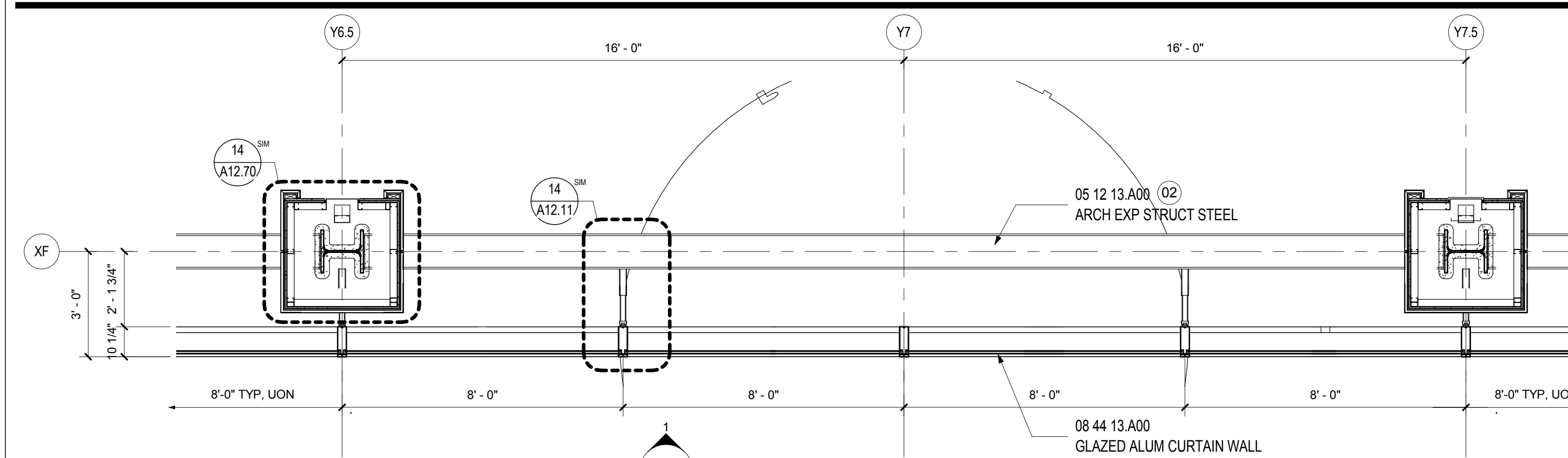

WALL TYPE D.1 - PLAN LEVEL 3

SCALE: 3/8" = 1'-0"

A02.03.05

2

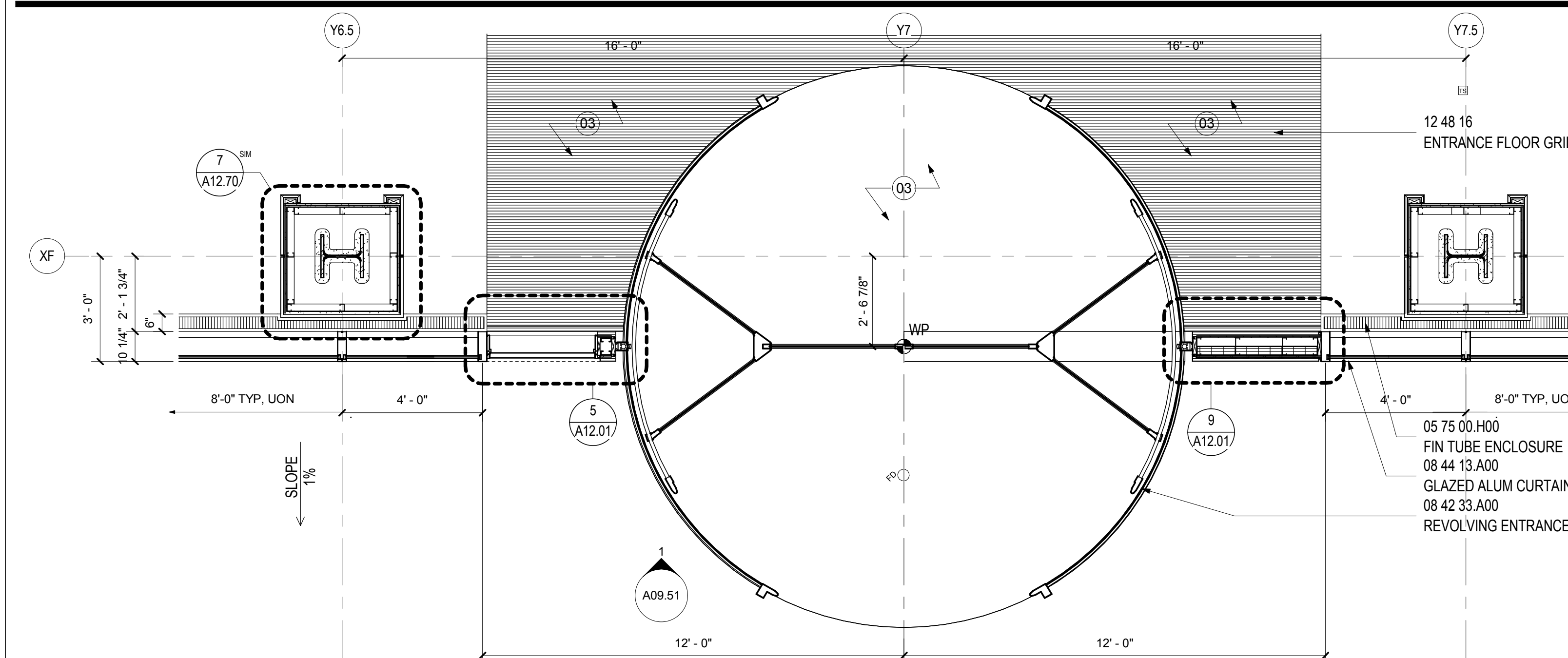

WALL TYPE D.1 - PLAN LEVEL 2

SCALE: 3/8" = 1'-0"

A02.02.05

3

SHEET NOTES

- 01 LINE OF CANOPY BEYOND
- 02 EXPOSED STEEL TO RECEIVE INTUMESCENT FIRE-RESISTANT COATING & FINISHES AS SCHEDULED
- 03 PROVIDE 1 1/2" SLAB DEPRESSION FOR INSTALLATION OF REVOLVING DOOR AND WALK OFF MAT. RE: A02.02.05 AND STRUCTURAL DRAWINGS FOR EXTENT.
- 04 PROVIDE METAL INFILL AT INTERSECTION.
- 05 LINE OF EXTENDED VERTICAL MULLIONS FOR ATTACHMENT TO BEAM.

GENERAL NOTES

- A. RE: FINISH SCHEDULE & PROJECT MANUAL FOR MULLION FINISH ASSOCIATED W/ GLAZING UNIT.

Portland International Jetport
1001 Westbrook Street
Portland, Maine 04102

Gensler
2020 K Street, Northwest
Suite 200
Washington DC 20006
Telephone 202.721.5200
Facsimile 202.872.8587

Issue	Date & Issue Description	By	Check
01	12/01/09		
02	75% CONSTRUCTION DOCUMENTS		
02	01/23/09		
03	95% CONSTRUCTION DOCUMENTS		
03	10/26/09		
	ISSUED FOR PERMIT		

Seal/Signature

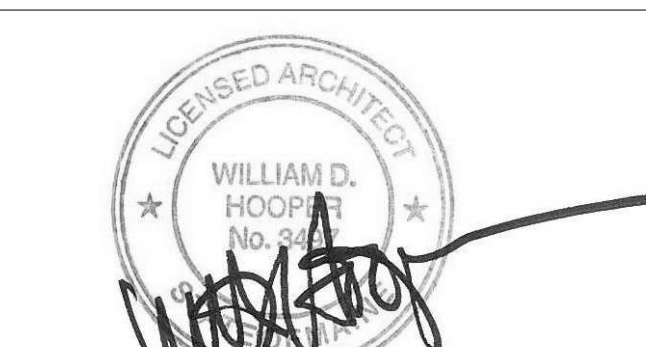

Project Name
PJM Terminal Enhancement

Project Number
09.6395.000

Description
WALL TYPE D.1

Scale
As indicated

A09.51

© 2009 Gensler