

WALL TYPE A.2 - SECTION

SCALE: 3/8" = 1'-0" A09.22

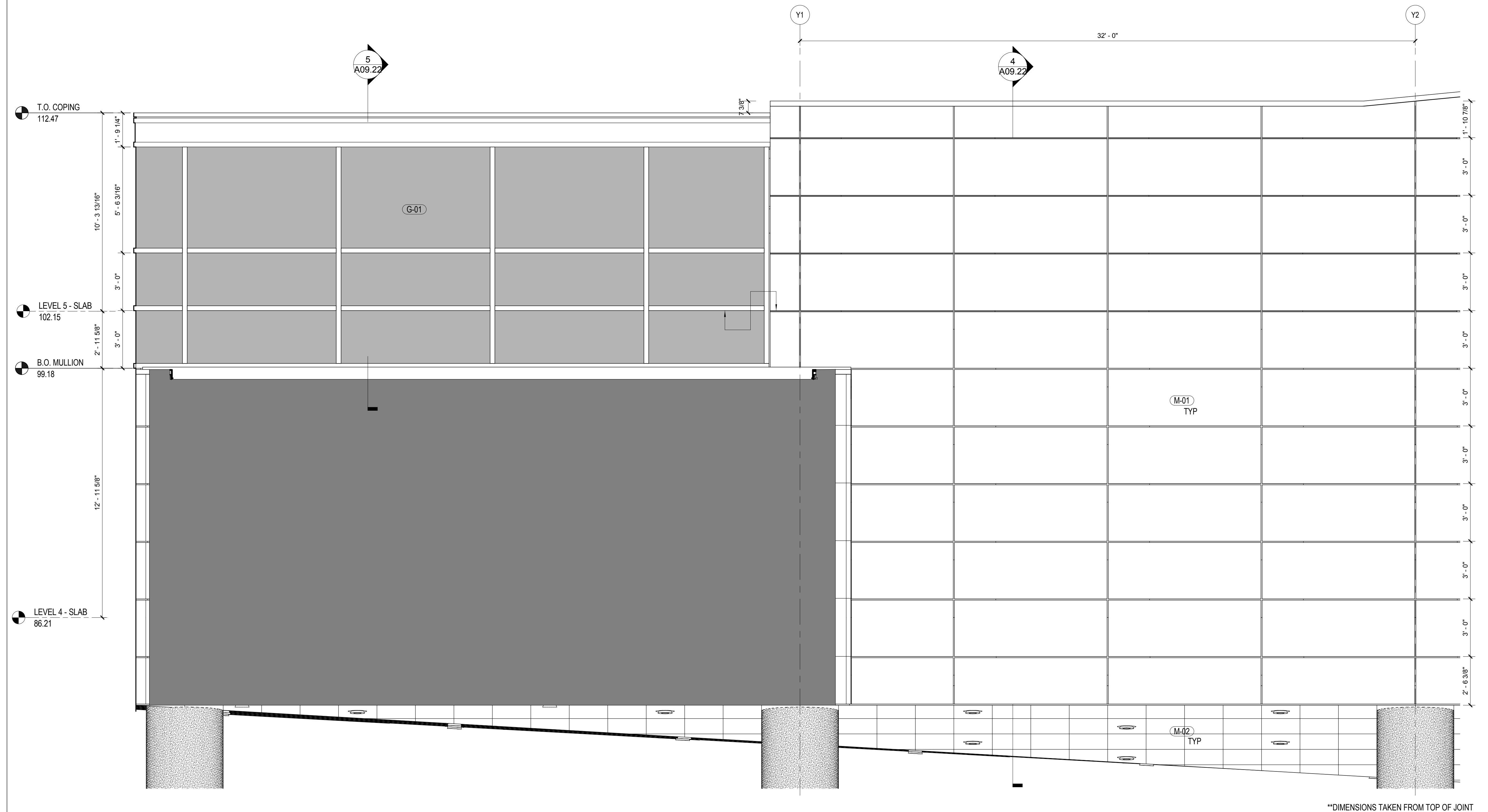

WALL TYPE A.2 - ELEVATION

SCALE: 3/8" = 1'-0" A09.03

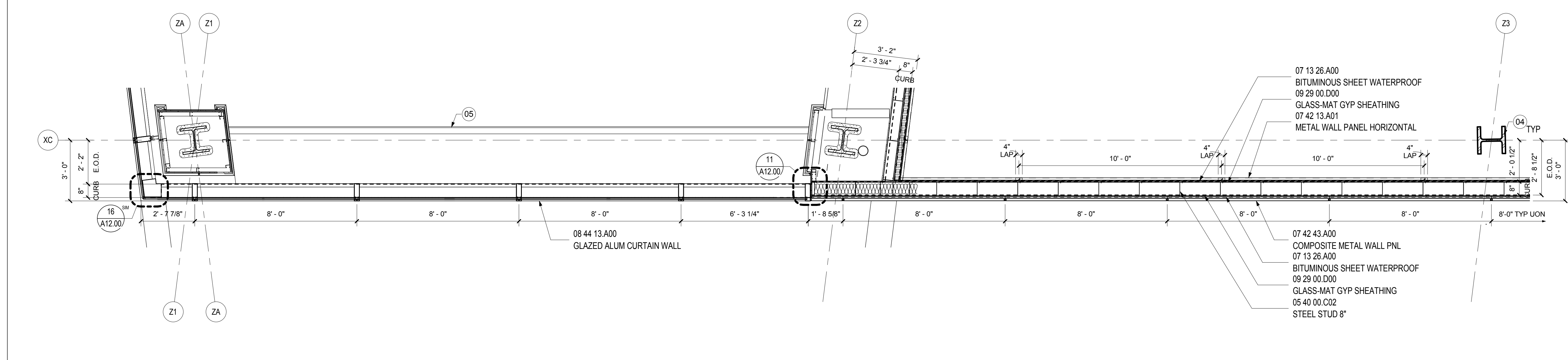

WALL TYPE A.2 - PLAN LEVEL 5

SCALE: 3/8" = 1'-0" A02.05.04

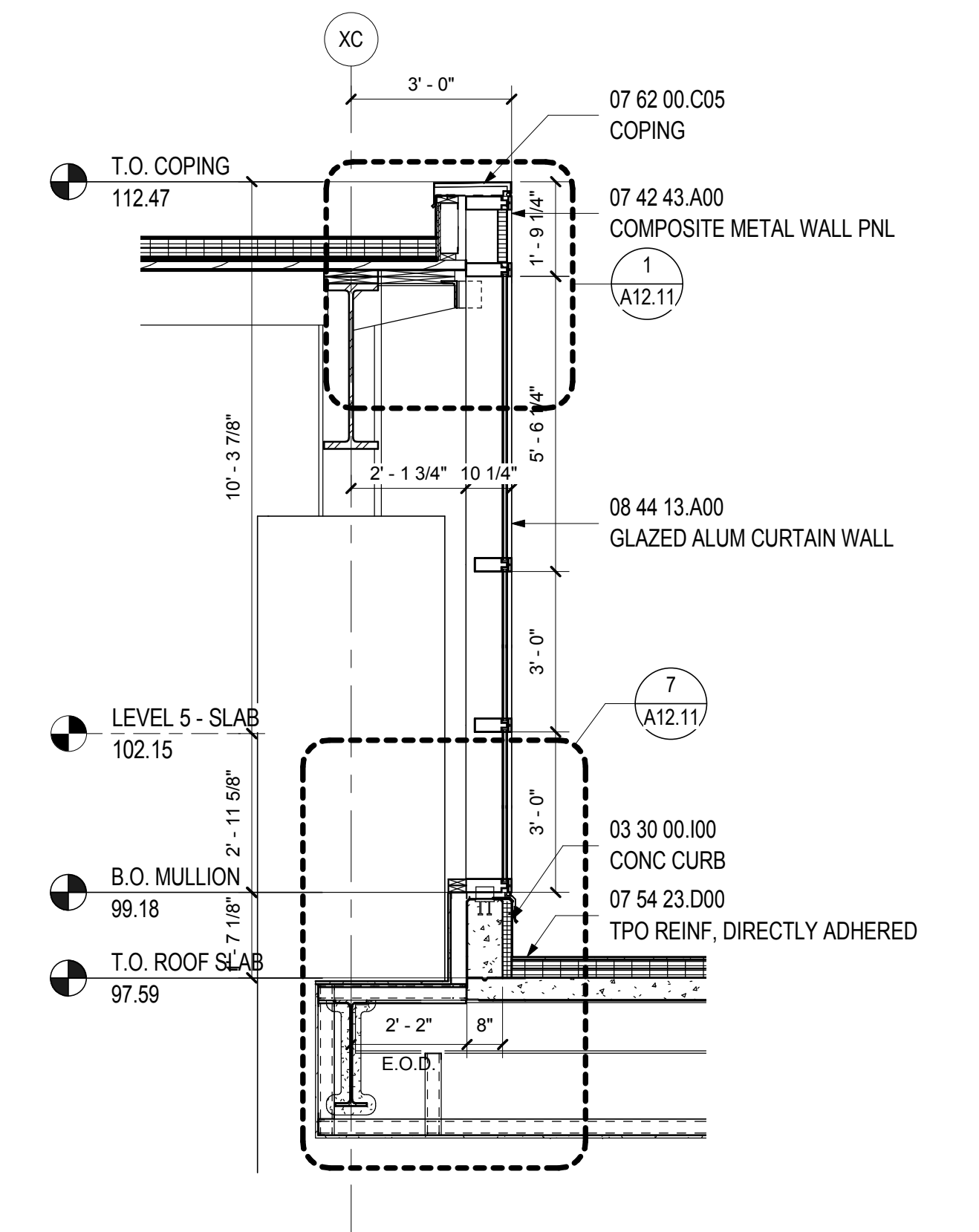

WALL TYPE B.7 - SECTION

SCALE: 3/8" = 1'-0" A09.22

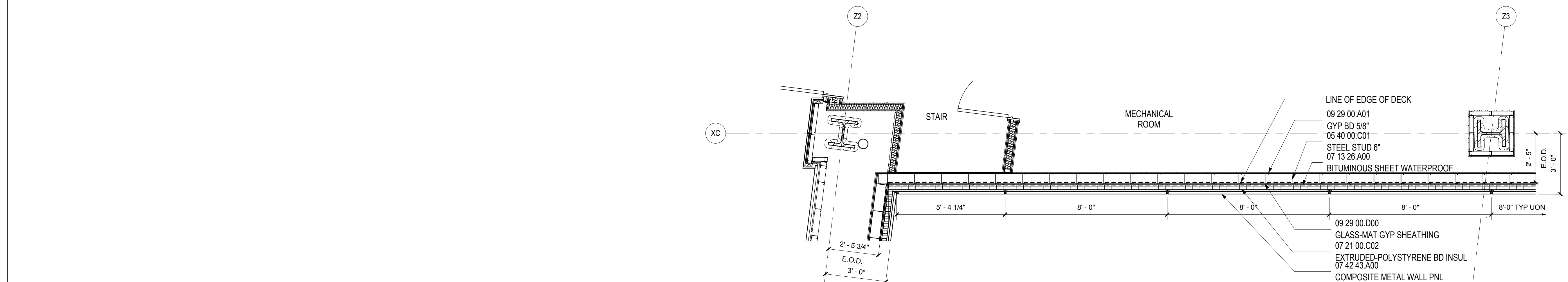

WALL TYPE A.2 - PLAN LEVEL 4

SCALE: 3/8" = 1'-0" A02.04.04

SHEET NOTES

- 01 FACADE BRANDING GRAPHICS, BACK LIT EXTRUDED PIN MOUNTED LETTERING, RE: A07 SERIES FOR MORE INFORMATION.
- 02 FACADE BRANDING GRAPHICS, INTERNALLY ILLUMINATED, RE: A07 SERIES FOR MORE INFORMATION.
- 03 AREA OF REMOVABLE METAL PANELS FOR ACCESS TO CHILLERS.
- 04 EXPOSED STEEL TO BE GLAVANIZED
- 05 LINE OF GYPSUM BOARD LEDGE BELOW

Portland International Jetport

1001 Westbrook Street
Portland, Maine 04102

Gensler

2020 K Street, Northwest
Suite 200
Washington DC 20006
Telephone 202.721.5200
Facsimile 202.872.8587

Issue	Date & Issue Description	By	Check
01	12/01/08		
02	75% CONSTRUCTION DOCUMENTS		
02	01/23/09		
03	95% CONSTRUCTION DOCUMENTS		
03	10/26/09		
	ISSUED FOR PERMIT		

Seal/Signature

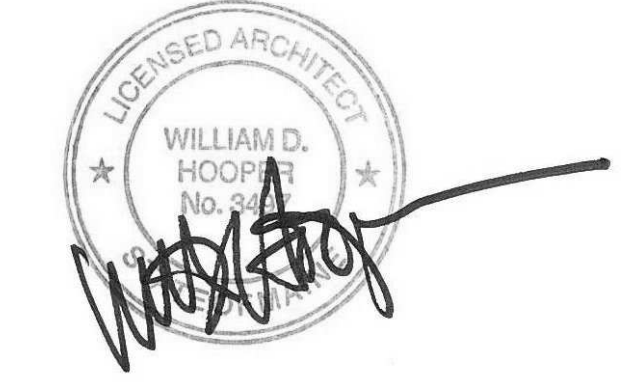

Project Name
PJM Terminal Enhancement

Project Number
09.6395.000

Description
WALL TYPE A.2

Scale
3/8" = 1'-0"

A09.22

© 2009 Gensler