

LINTEL DETAIL
SCALE T = 1-0"

14
S4

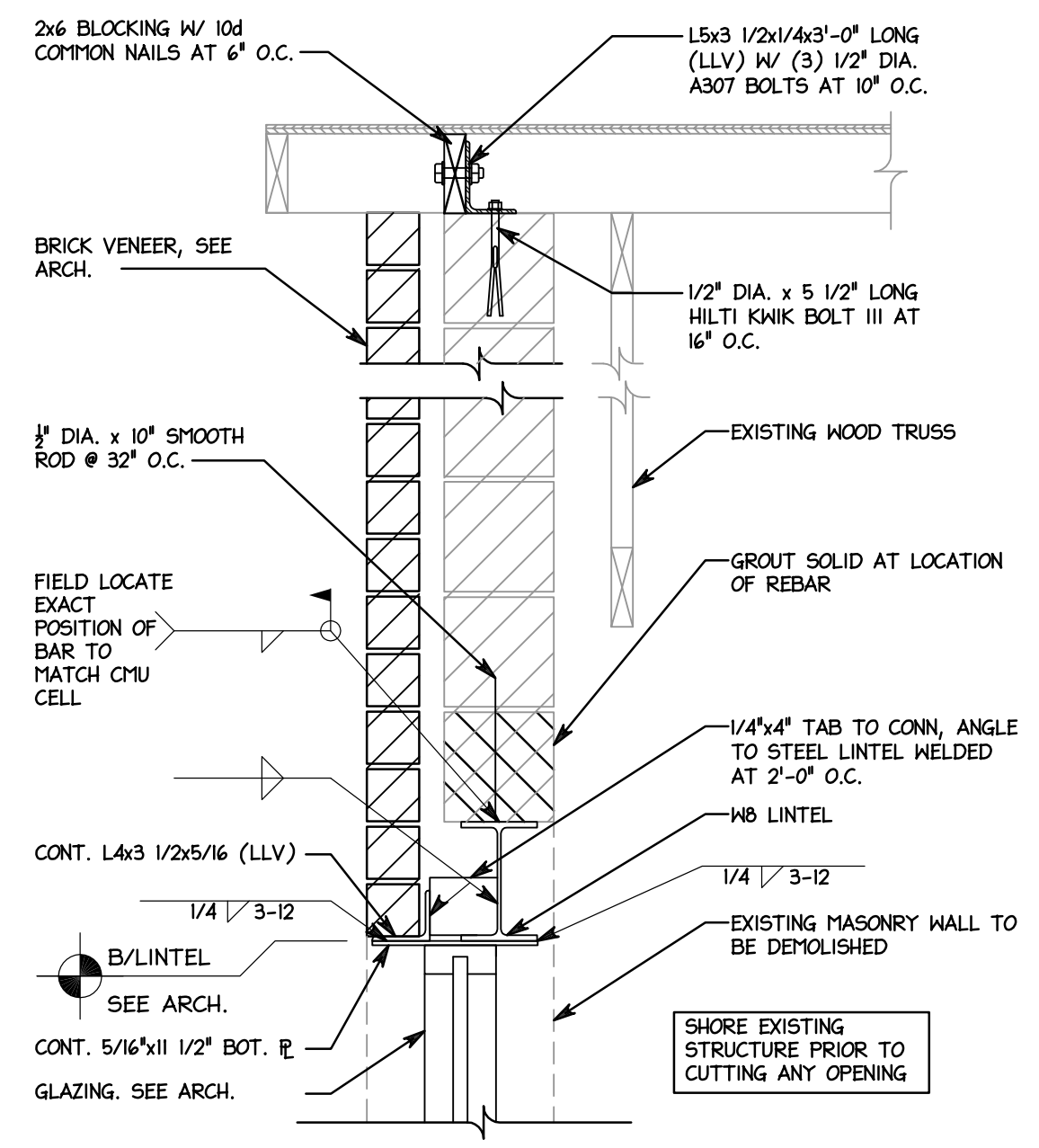

LINTEL DETAIL
SCALE T = 1-0"

13
S4

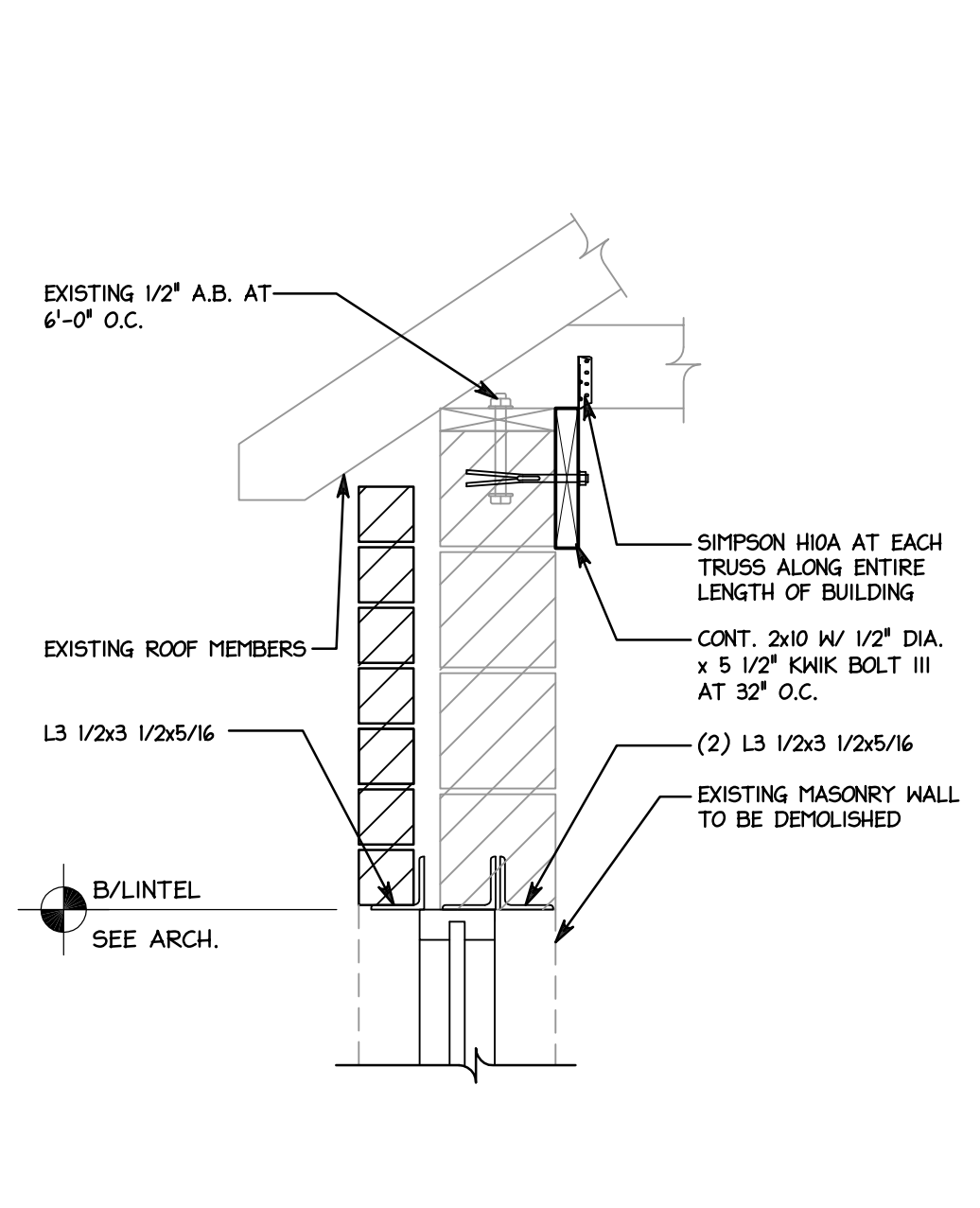

LINTEL DETAIL
SCALE T = 1-0"

12
S4

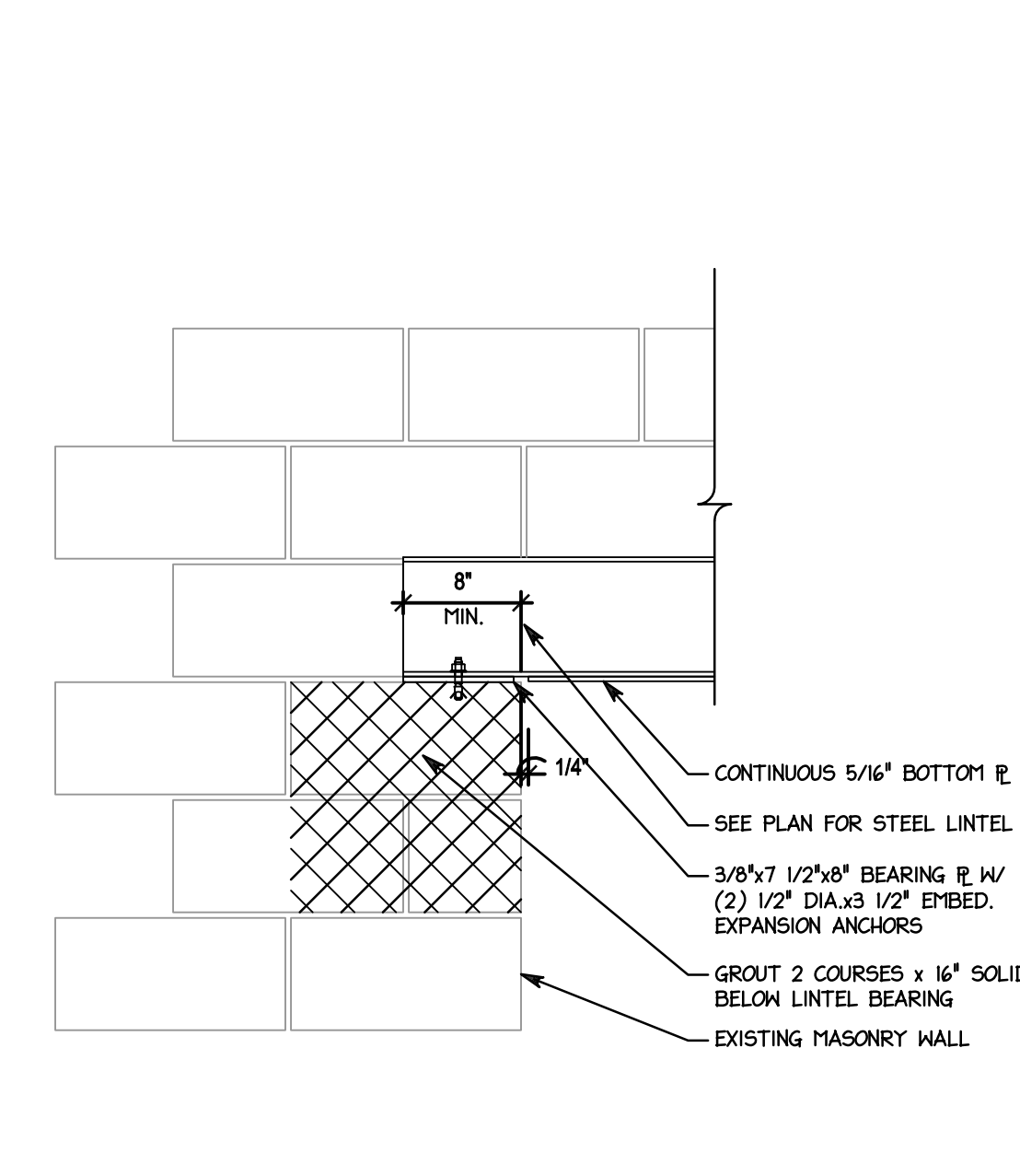

LINTEL BEARING
SCALE T = 1-0"

11
S4

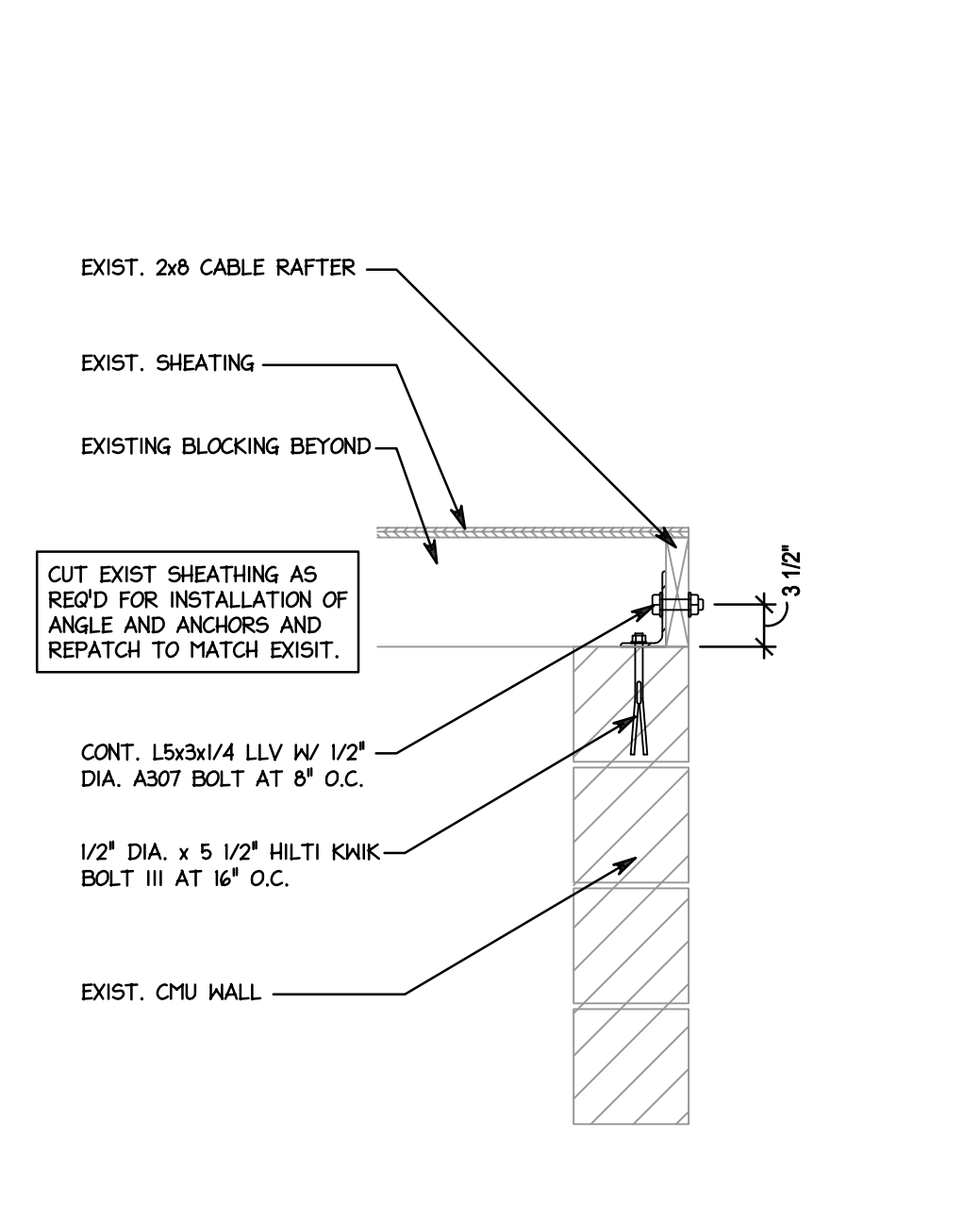

END RAFTER CONNECTION
SCALE T = 1-0"

10
S4

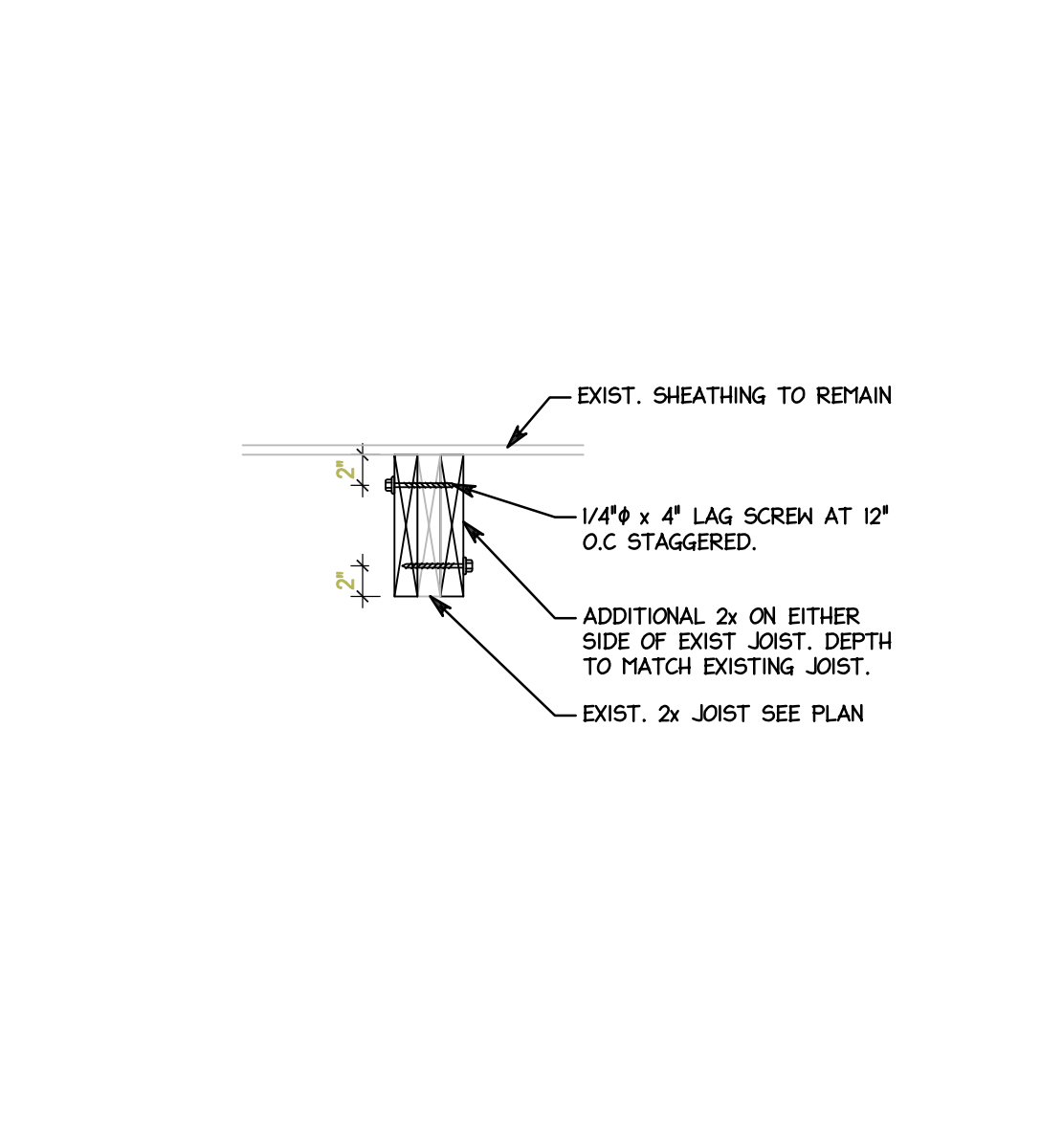

JOIST REINFORCING
SCALE T = 1-0"

9
S4

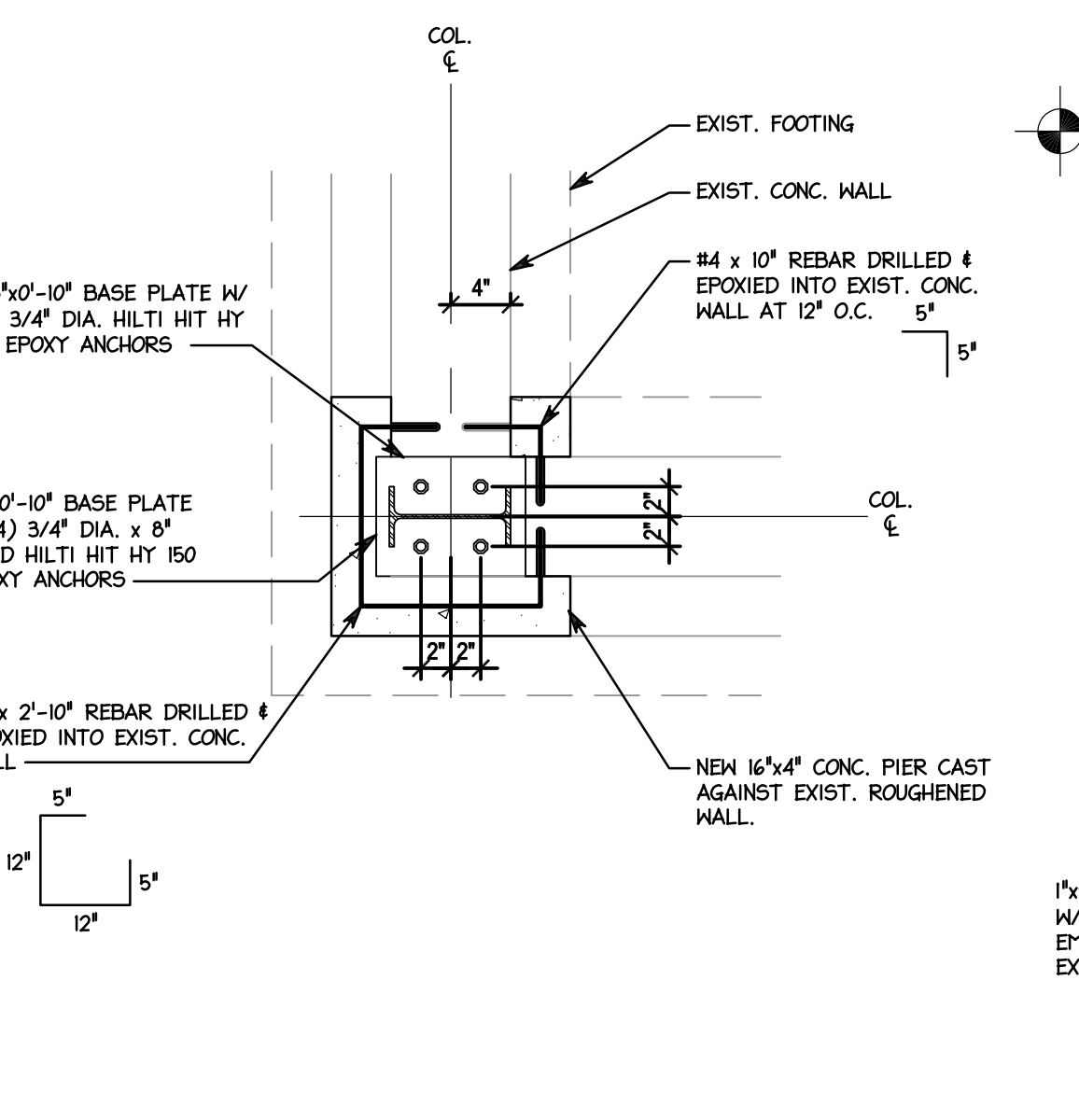

BASE PLATE
SCALE T = 1-0"

8
S4

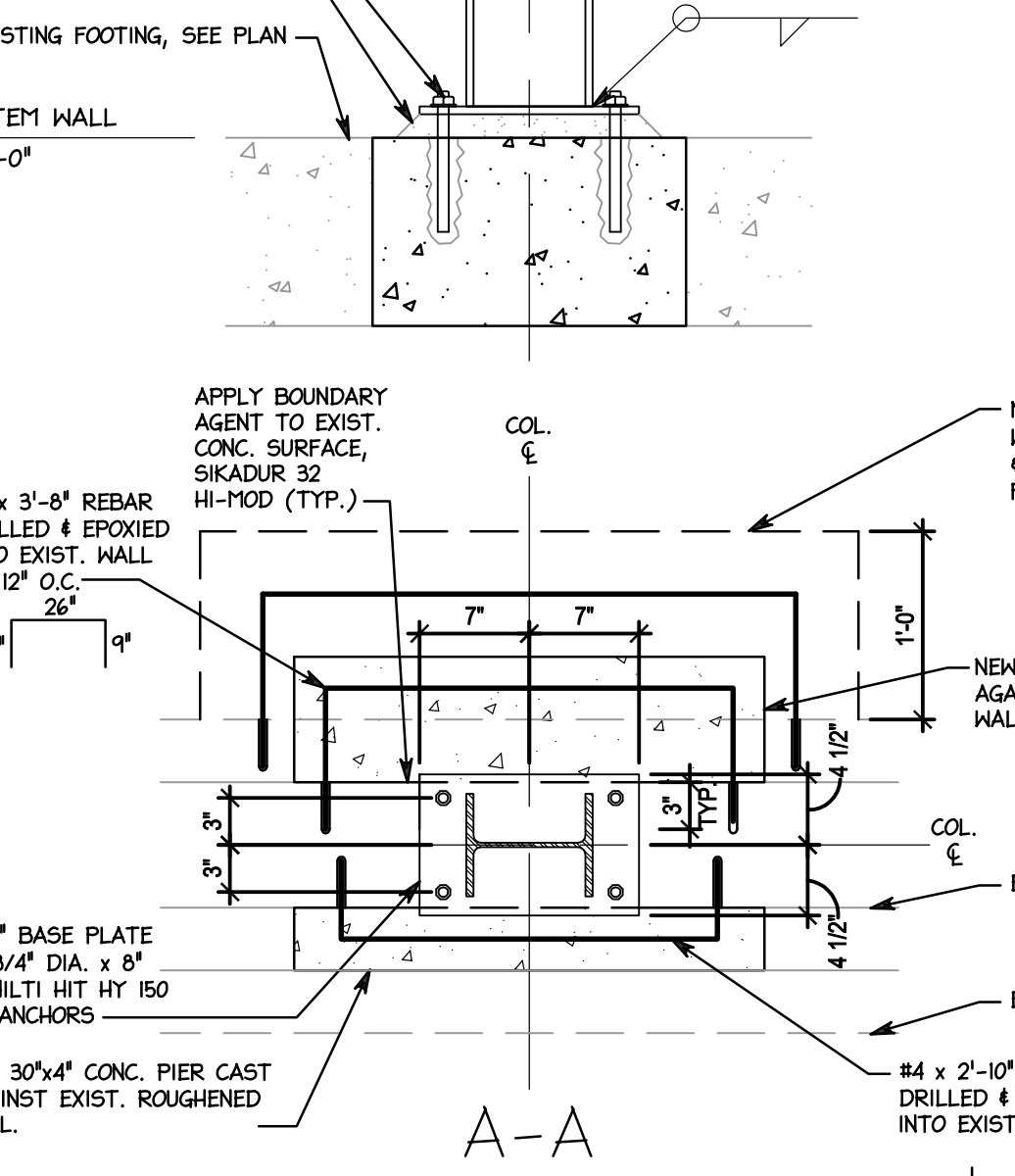

BASE PLATE
SCALE T = 1-0"

7
S4

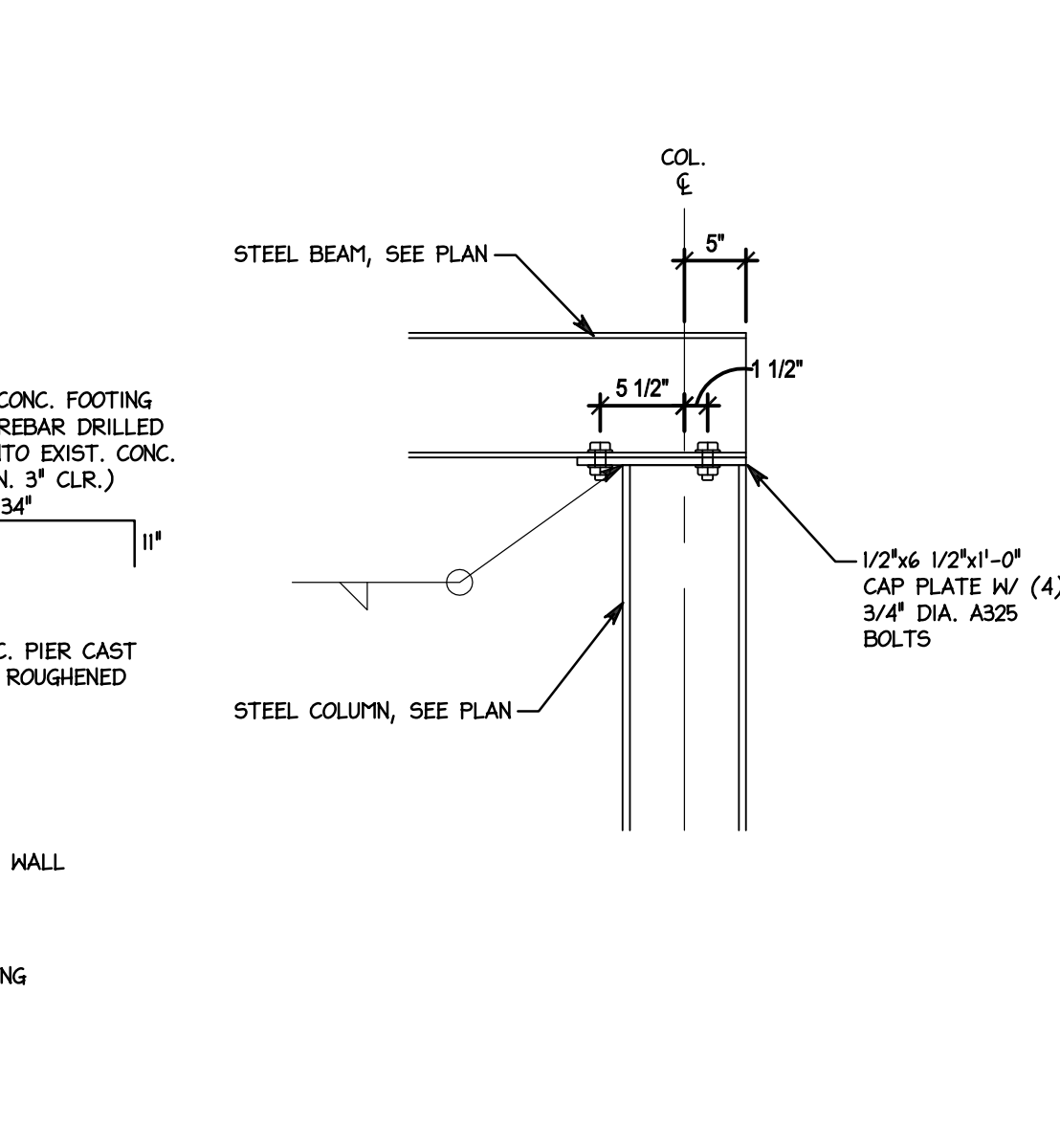

BEAM / COLUMN CONNECTION
SCALE T = 1-0"

6
S4

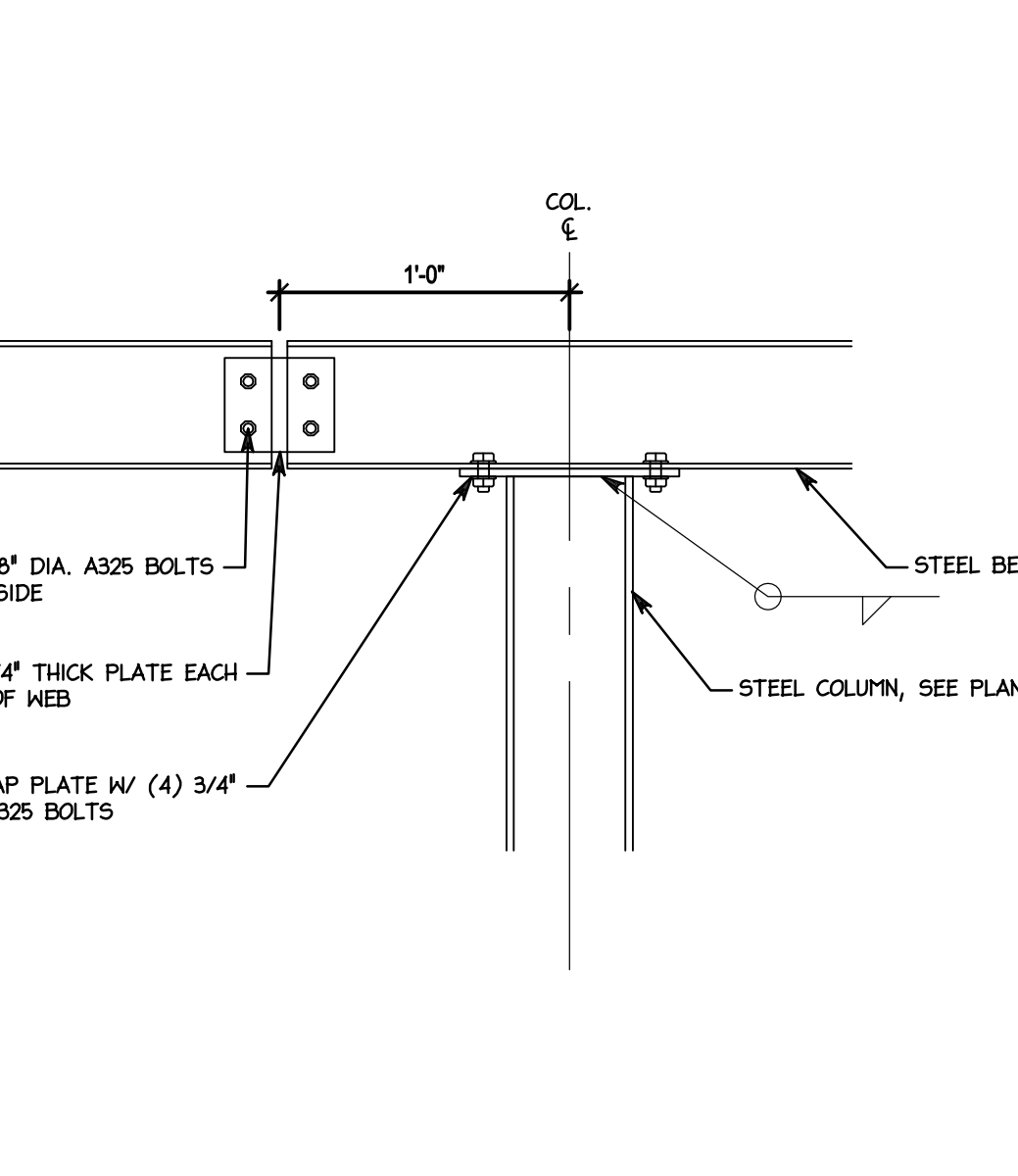

BEAM / COLUMN CONNECTION
SCALE T = 1-0"

5
S4

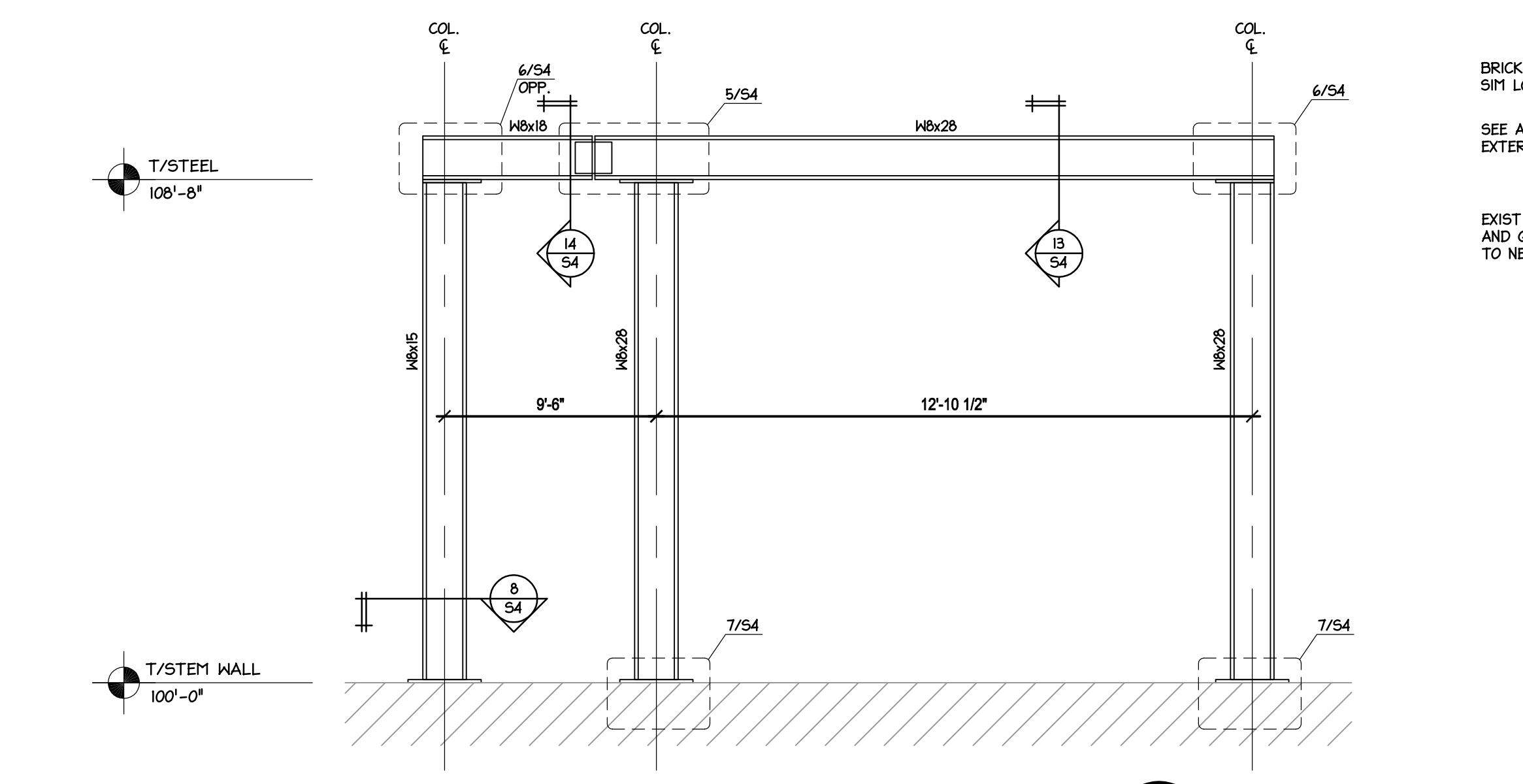

MOMENT FRAME
SCALE N.T.S.

4
S4

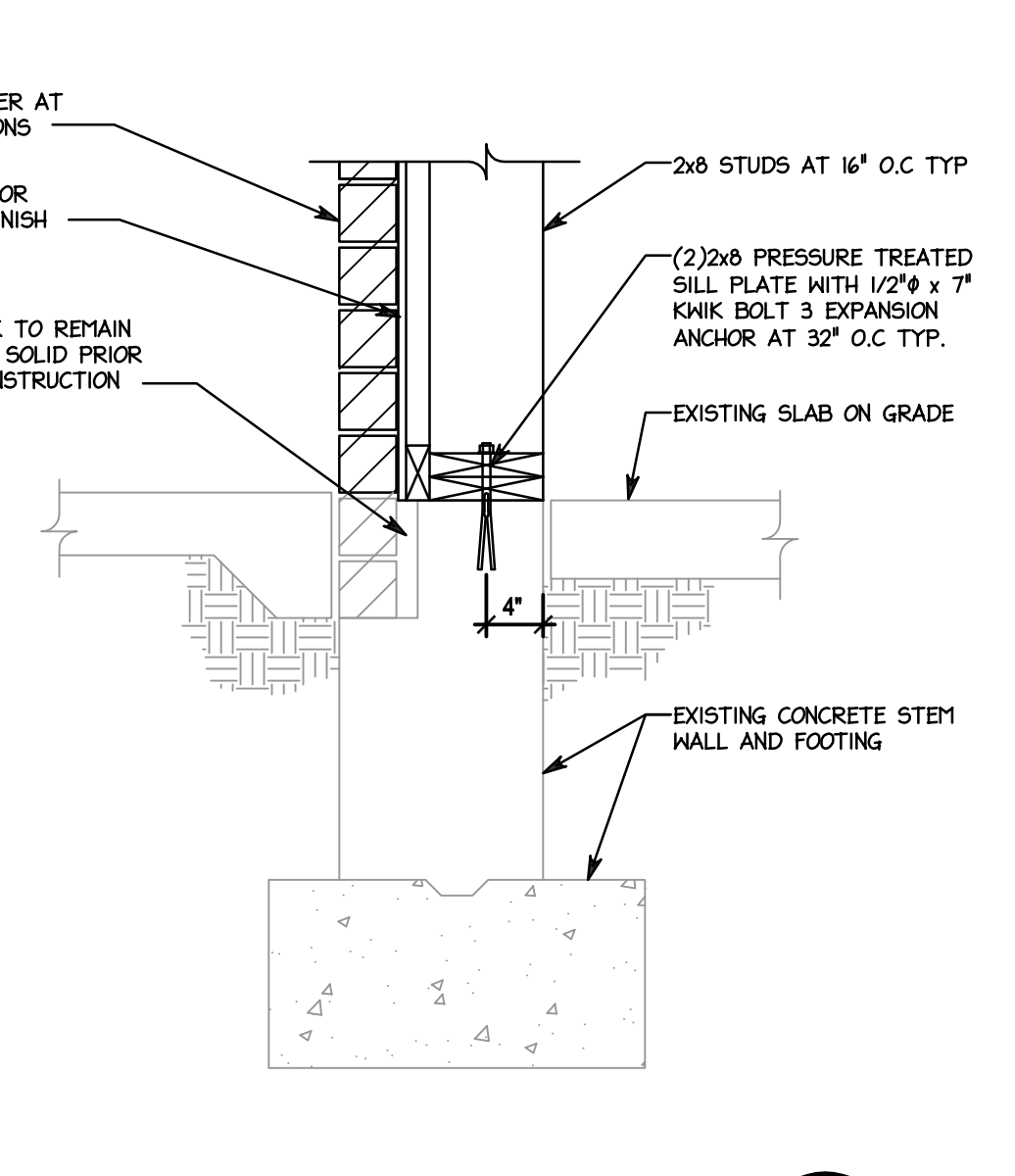

FOUNDATION DETAIL
SCALE T = 1-0"

3
S4

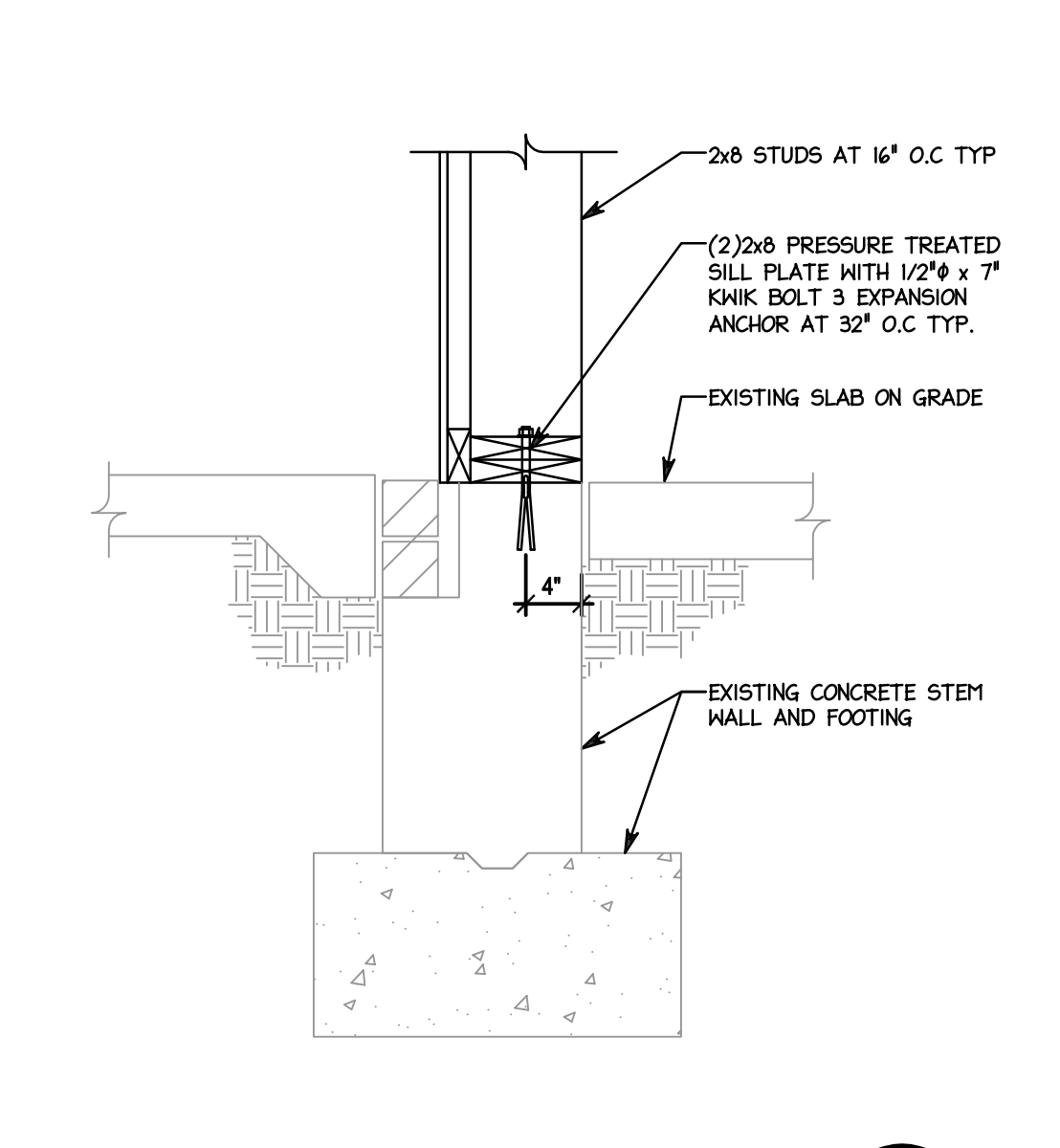

FOUNDATION DETAIL
SCALE T = 1-0"

2
S4

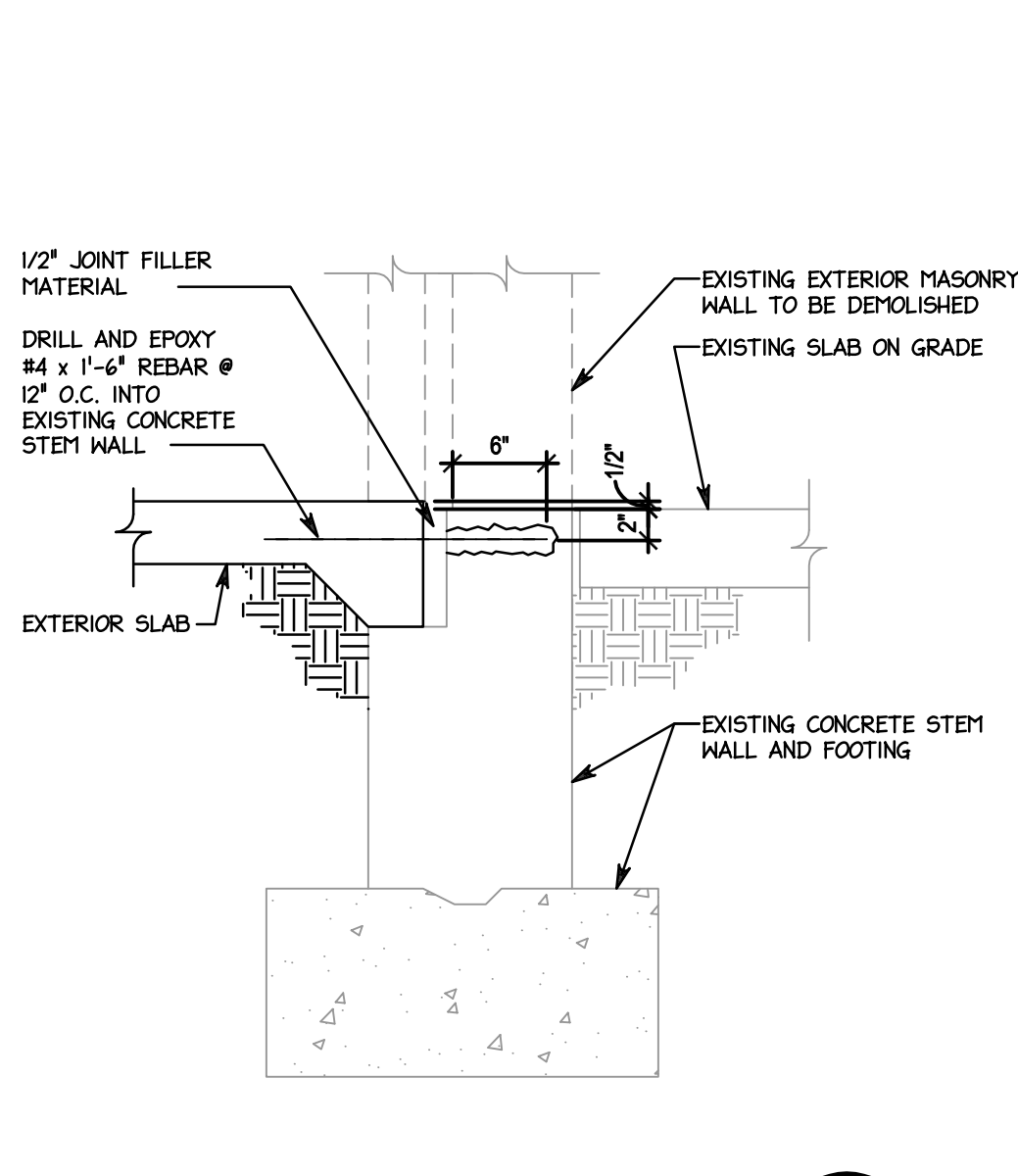

FOUNDATION DETAIL
SCALE T = 1-0"

1
S4

REVISIONS:
DATE ISSUED: 07-02-2008
INDICATES NO REVISION TO THIS SHEET

Atlanta
Boston
Chicago
Dallas
Los Angeles
Miami
Sacramento

wd partners

7007 Discovery Blvd.
Dublin, OH 43017
614.884.7777
wdpartners.com

Tim Hortons
1408 CONGRESS STREET
PORTLAND, ME 04102

STRUCTURAL DETAILS
DRAWN BY: MBL CHECKED BY: MLL

SAI # 0838
DRAWING NUMBER:
S4