

DESIGNED	CHECKED
CLB	JRS
A. JRS 11-18-15 SITE PLAN SUBMITTAL	
REV. BY: DATE: STATUS:	
THIS PLAN SHALL NOT BE MODIFIED WITHOUT WRITTEN PERMISSION FROM SEBAGO TECHNIQS, INC. ANY ALTERATIONS AUTHORIZED OR OTHERWISE, SHALL BE AT THE USER'S SOLE RISK AND WITHOUT LIABILITY TO SEBAGO TECHNIQS, INC.	

SEBAGO TECHNIQS
 WWW/SEBAGO TECHNIQS.COM
 75 John Roberts Rd., Suite B 04240
 South Portland, ME 04106
 Tel: 207-200-2100 Tel: 207-783-5656

DETAILS
 OF: 9 WESTLAND AVENUE
 PORTLAND, MAINE
 FOR RECORDED OWNER:
MAINE FIBER COMPANY
 482 CONGRESS ST., SUITE 100
 PORTLAND, MAINE 04101

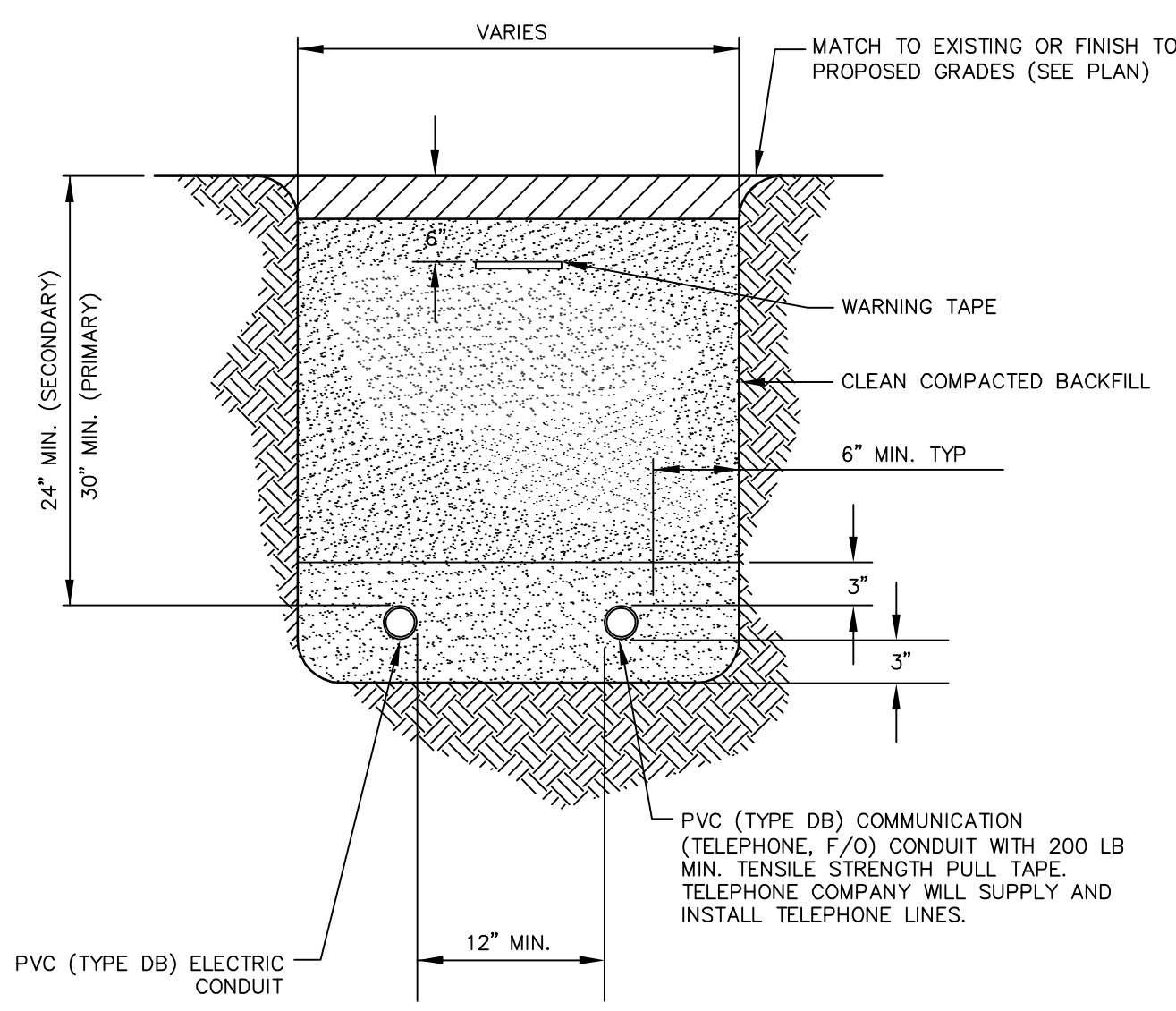

UNDERGROUND CONDUITS	
DESIGNATION	SIZE, IN.
ELECTRIC	2 1/2"
COMMUNICATIONS	4"

NOTES:
 1. COORDINATE ALL CONDUIT REQUIREMENTS WITH LOCAL UTILITY COMPANIES.

UTILITY TRENCH
 NOT TO SCALE

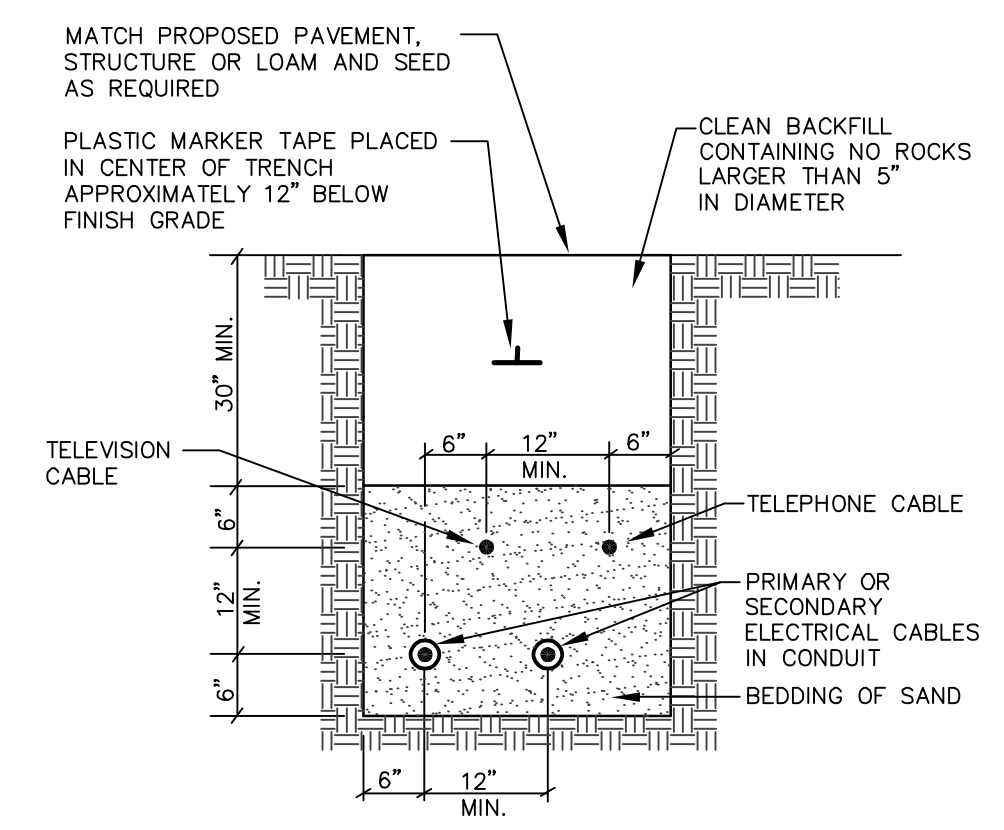

CABLES TO BE ENCASED IN SCHEDULE 40 PVC CONDUIT WHEN RUN BENEATH PAVED AREAS.

TYPICAL UNDERGROUND CABLE INSTALLATION
 NOT TO SCALE

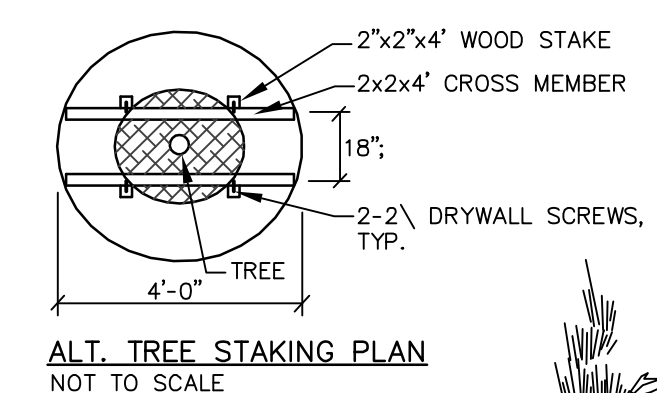

ALT. TREE STAKING PLAN
 NOT TO SCALE

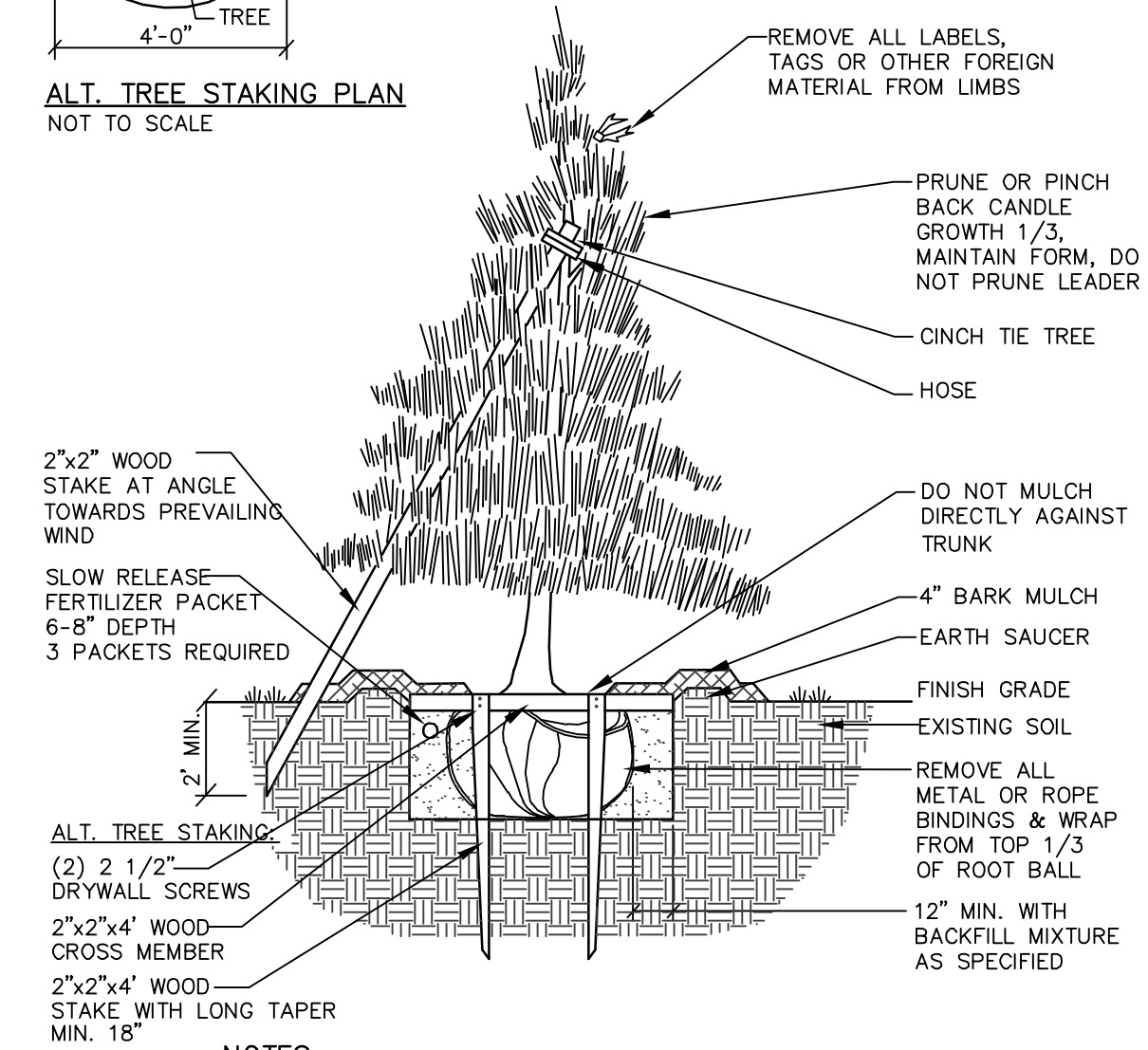

NOTES:
 INSTALL STAKES AND GUYS TO TREES IF THE FOLLOWING APPLY:
 1. THE TREE IS OF SUBSTANTIAL SIZE.
 2. THE PLANTING LOCATION IS EXTREMELY WINDY, AS ON OPEN UNDEVELOPED SITES.
 3. THE PLANTING LOCATION IS COMPRISED OF SAND OR OTHER LOOSE TEXTURED SOILS.
 4. IF STAKES AND GUYS ARE REQUIRED, REMOVE AFTER ONE YEAR TIME.

DECIDUOUS TREES UNDER 2" CALIPER OR UNDER 8' IN HEIGHT
EVERGREEN TREES 7'-0" IN HEIGHT & UNDER

NOT TO SCALE

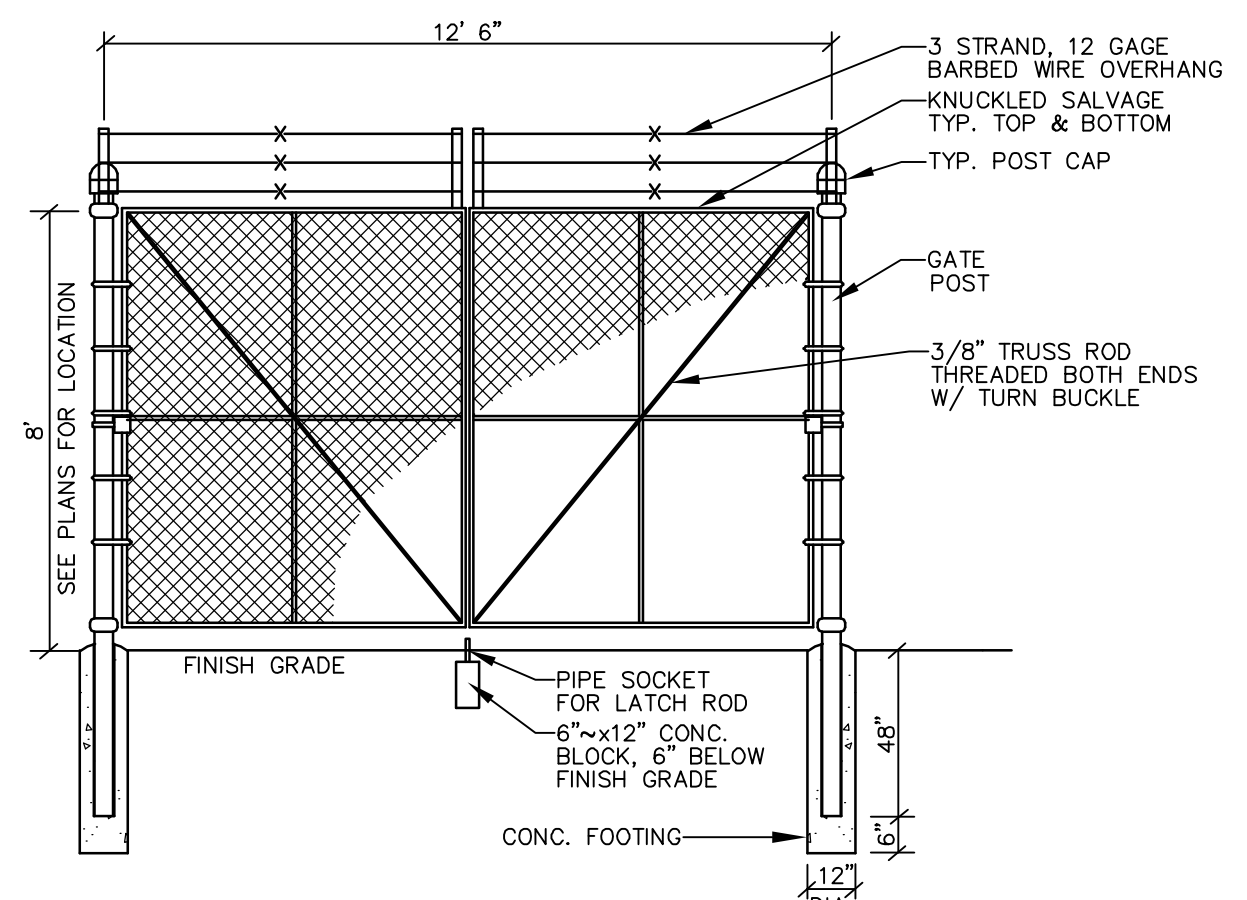

TYPICAL CHAIN LINK GATE
 NOT TO SCALE

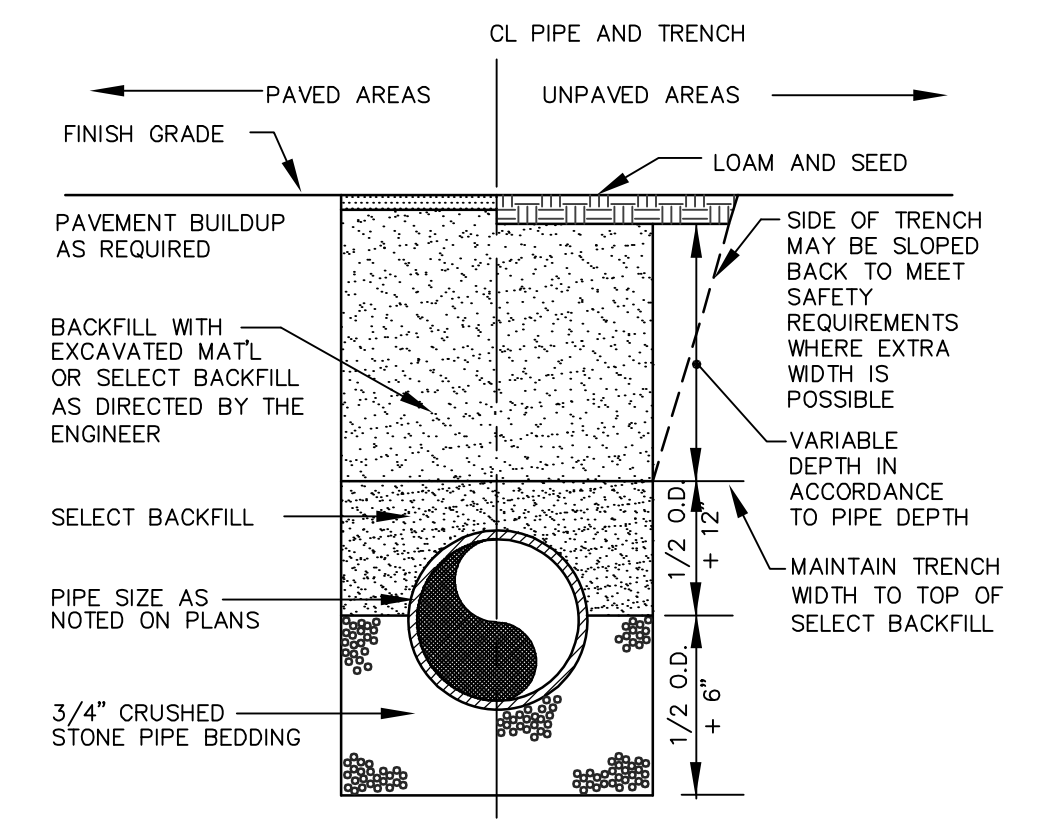

TYPICAL TRENCH SECTION
 NOT TO SCALE