

**FOUNDATION NOTES & CONCRETE SPECIFICATIONS**

- FOUNDATION AREA SHALL BE EXCAVATED TO THE DEPTH AND DIMENSIONS SHOWN ON THE PLANS. EXISTING LEDGE AND ALL OTHER EXISTING UNSUITABLE MATERIAL SHALL BE REMOVED AND LEGALLY DISPOSED OF OFF-SITE. THE SUBGRADE SHALL BE ROLLED WITH A 1-TON, VIBRATORY, WALK-BEHIND ROLLER AT A SPEED OF LESS THAN 2 FPS, 6 PASSES MINIMUM, TO PROVIDE UNYIELDING SURFACE.
- UNDERCUT SOFT OR "WEAVING" AREAS A MINIMUM OF 12 INCHES DEEP. BACKFILL UNDERCUT AREA WITH FILL MEETING THE SPECIFICATIONS OF STRUCTURAL FILL. (SEE NOTE #3)
- CONCRETE TO HAVE A MINIMUM 28 DAY COMPRESSIVE STRENGTH ( $f'_c$ )=5000 PSI. CONCRETE TO BE AIR ENTRAINED, DESIRED AIR CONTENT TO BE 6% (PLUS OR MINUS 2%)
- BAR REINFORCING TO BE ASTM A615 GRADE 60.
- WELDED WIRE FABRIC TO CONFORM TO THE REQUIREMENTS OF ASTM A185. WIRES FOR FABRIC TO CONFORM TO THE REQUIREMENTS OF ASTM A82.
- COORDINATE WITH MANUFACTURER OF PREFABRICATED SHELTER FOR LOCATION OF ATTACHMENTS TO BASE SLAB.
- ALL REINFORCING TO HAVE 2" MINIMUM CONCRETE COVER.
- ALL CONCRETE MATERIALS AND WORKMANSHIP SHALL CONFORM TO LATEST EDITION OF ACI 318 BUILDING CODE, AND IBC 2009.

**UNITED CONCRETE PRODUCTS, INC.  
GENERAL NOTES:**

- CONCRETE COMPRESSIVE STRENGTH: **5,000 PSI @ 28 DAYS.**
- STRUCTURAL SHALL BE WET CAST USING A SELF COMPACTING CONCRETE MIX.
- REINFORCING STEEL DEFORMED BARS CONFORM TO LATEST ASTM SPECIFICATIONS A615, GRADE 60, 1-1/2" MINIMUM COVER, U.N.O.
- CONCRETE STRUCTURE TO HAVE 5" SOLID WALLS WITH 1/2" FLUTES, 5" THICK FLOOR AND 6" THICK ROOF.

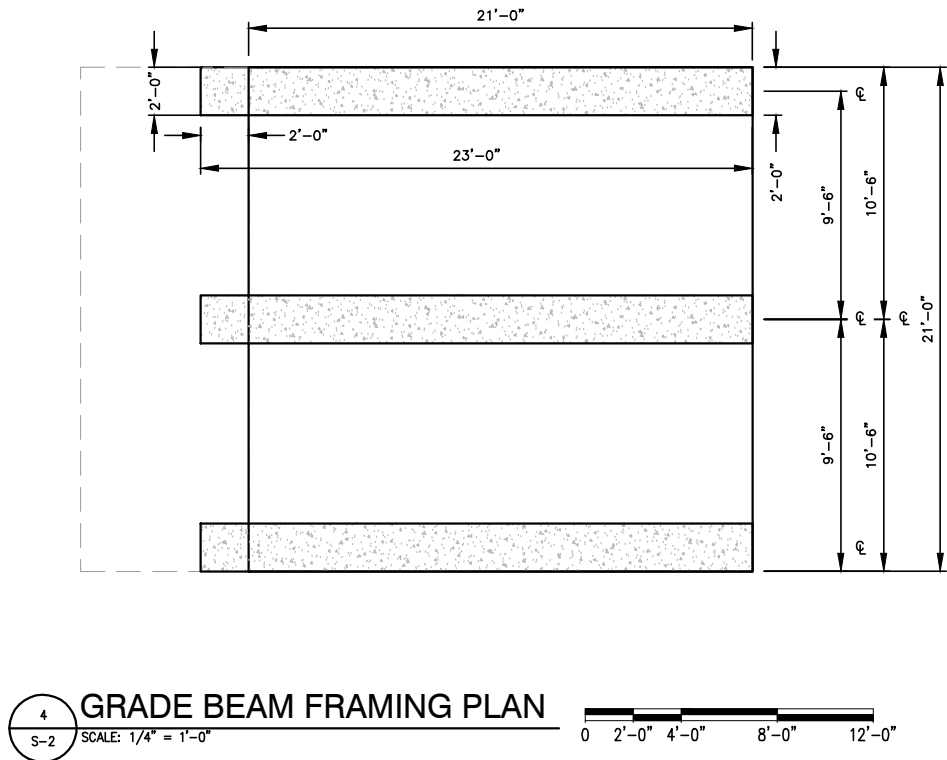
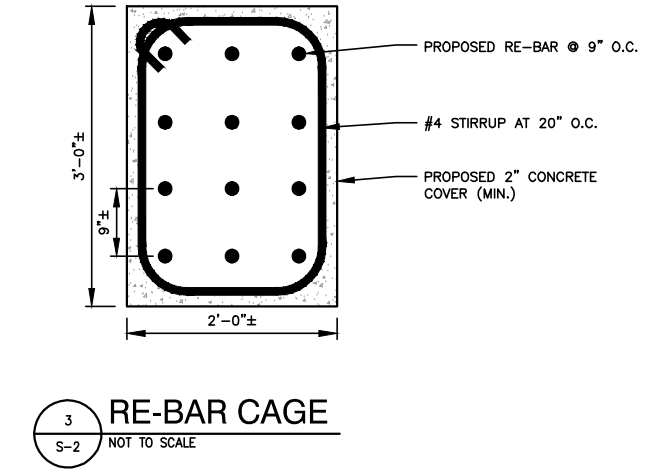
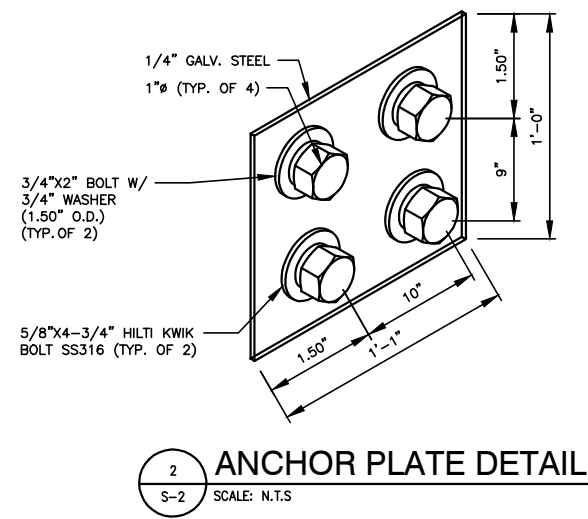
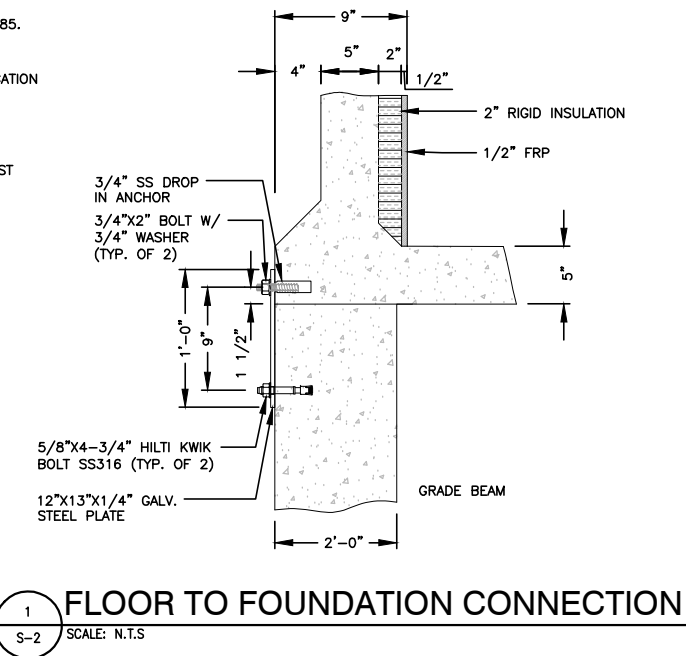

**MFC**  
Maine Fiber Company  
482 CONGRESS STREET, SUITE 100  
PORTLAND, ME 04101

**Hudson Design Group, Inc.**  
1600 OSGOOD STREET  
BLD 20 N, SUITE 3090  
N. ANDOVER, MA 01845  
TEL: (978)-557-5553  
FAX: (978)-336-5586

STATE OF MAINE  
DEREK J. GREASER  
NO. 12752  
LICENSED ENGINEER  
DATE

REVISIONS		
REV. #	DATE	DESCRIPTION
0	03/02/16	ISSUED FOR REVIEW

PROJECT NO.	DESIGNED BY: RP	SCALE:
	DRAWN BY: VP	AS SHOWN
	CHECKED BY: DPH	

SITE NAME:  
**MFC  
PORTLAND**

SITE ADDRESS:  
9 WESTLAND AVENUE  
PORTLAND, ME 04101

SHEET TITLE:  
**SHELTER FOUNDATION  
DETAILS**

SHEET NO:  
**S-2**