

**POMEROY STREET  
PROFILE**

SCALE  
VERTICAL: 1" = 5'  
HORIZONTAL: 1" = 25'

SAWCUT EX. PAVT AT TRENCH  
LOCATION AND PAVT JOINT  
SEE DETAIL

CORE HOLES AT UTILITY  
ENTRANCES AND INSTALL  
RUBBER BOOT PER CITY  
TECHNICAL MANUAL, SEE  
DETAILS

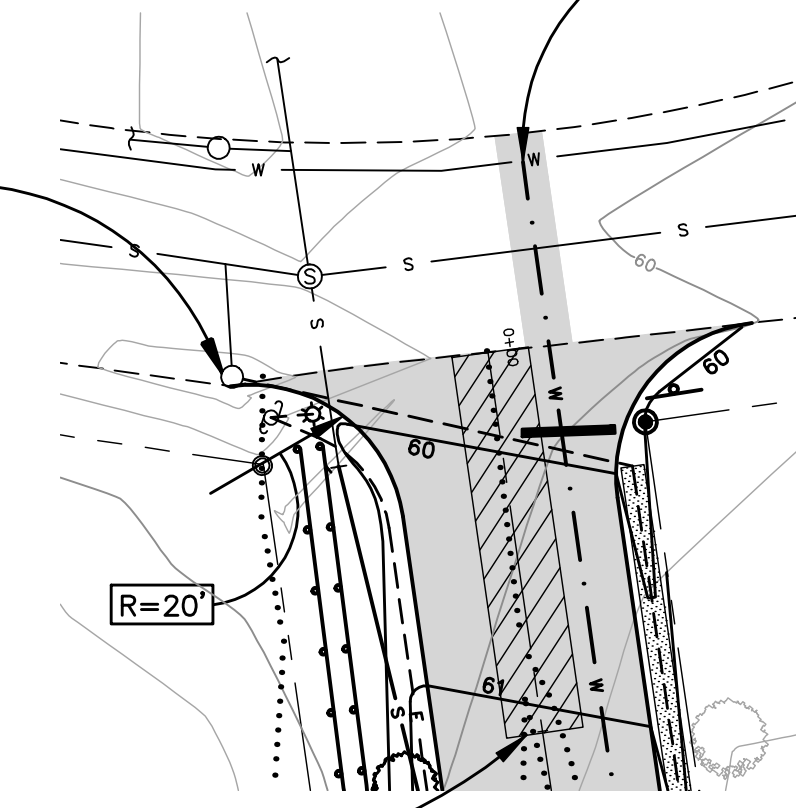

20' STABILIZED CONSTRUCTION  
ENTRANCE, SEE DETAIL SHT 5

**ENTRANCE PLAN**

SCALE: 1" = 25'

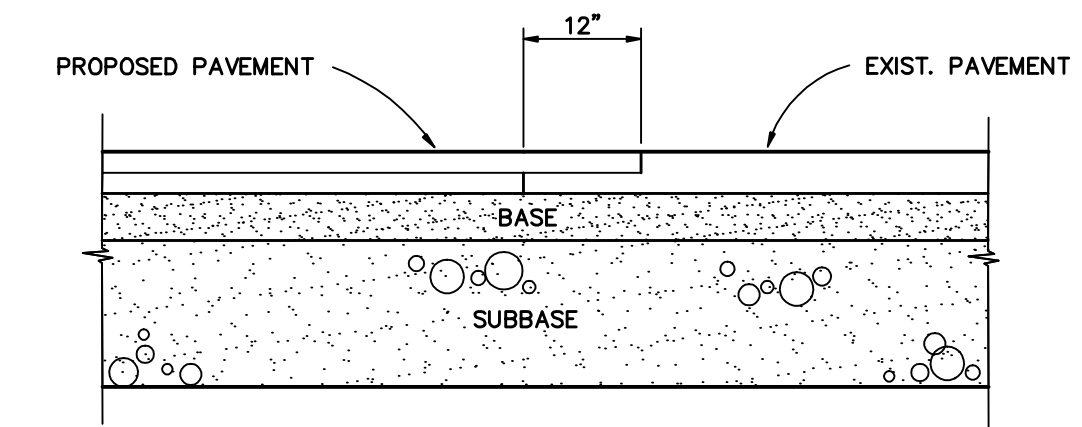

SAWCUT EXIST. PAVEMENT ALONG A SMOOTH LINE TO  
A NEAT EVEN VERTICAL JOINT, APPLY TACK  
PRIOR TO PROPOSED PAVING (AS REQ'D)

**PAVEMENT JOINT DETAIL**

N.T.S.

NO.	DATE	DESCRIPTION
1	1/24/12	Submitted Amended Site Plan
2	3/12/12	Submitted Level I & II Site Plans
3	8/29/12	Revisions for Level I & II Applications
4	11/22/12	Revisions for Level I & II Applications Per City Comments
5	4/15/13	Revisions for Level I & II Applications Per City Comments



**BH2M**  
Berry, Huff, MacDonald, Milligan Inc.  
Engineers, Surveyors  
28 Stone Street  
Columbia, Maine 04008  
Tel: (207) 859-2771  
Fax: (207) 859-6550

FOR  
Chabed Libavitch Of Maine Inc.  
Pomeroy Street  
Portland, Maine

**MINOR STREET  
CONSTRUCTION**

**POMEROY STREET**  
PORTLAND, MAINE

DESIGNED W. Thompson	DATE Jan. 2012
DRAWN Dept.	SCALE As Noted
CHECKED W. Thompson	JOB. NO. 11093

SHEET  
**3**

REPRODUCTION OR REUSE OF THIS  
DOCUMENT WITHOUT THE  
EXPRESSED WRITTEN CONSENT  
OF BH2M INC. IS PROHIBITED