

SOIL TREATMENT & STABILIZATION NOTES - WETLAND PLANTINGS

- Dredge material for use within the top 6 inches of the Wetland Planting Zones, as described in the Plans and Details, shall be augmented with Erosion Control Mix (Casella Organics, Portland, ME or equal) at a mixture ratio of 3 parts dredge material to 1 part EC Mix or as otherwise determined by soil testing described below.
- Contractor should adjust amendment and/or mixing ratio based on soil sampling of the dredge material to be augmented and to achieve optimal growing conditions for the specified wetland plant species. Contractor shall provide sampling data, augmentation material specifications and mixing ratios to the City for approval. Treatment strategy shall be prepared by a wetland professional.
- Augmented material shall be solely used for the top 6 inches of the wetland planting zones unless otherwise recommended by the wetland professional and authorized by the City Engineer. All grades shall be as specified on the plans.
- Soils shall be stabilized as shown in the Typical Section / Approach to Wetland Plantings detail. Root Carpet shall be as supplied by Cardo JFNew, 128 Sunset Drive, Walkerton, IN 46574, Tel. 547-586-2412 - or an approved equal. Coir Weed Mat shall be as supplied by Granite Environmental, Inc., PO Box 780928, Sebastian, FL 32978, Tel. 888-703-9889 - or approved equal. Products shall be installed per manufacturer's specifications.

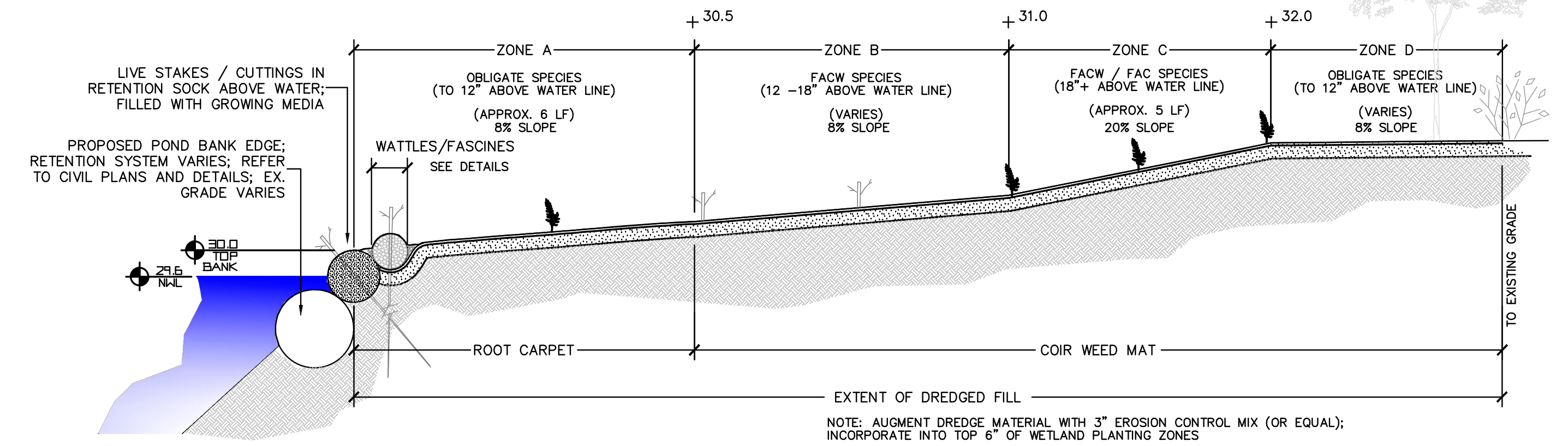

TYPICAL SECTION / APPROACH TO WETLAND PLANTINGS

GENERAL PLANTING NOTES - WETLAND PLANTINGS (POND)

- Native species were chosen based on several factors, including known suitability for wetland enhancement plantings, known ability to provide wildlife habitat, and availability of stock from local nurseries. If substitutions are required due to stocking or other issues, only native plants that can survive in similar hydrologic regime and provide a similar functional role will be considered. Any requests for substitutions in plant material, including size or condition, must be submitted to the City for review and approval.
- Reference the Typical Section / Approach to Wetland Plantings for guidance related to species placement. Plant placement will need to respond to the specific field conditions and suitability of the growing conditions for the species. Unless otherwise directed plants shall be spaced within the ranges specified herein.
- Plantings within Viewshed Overlay Areas, as noted on the Plan, shall not exceed 5 feet mature height throughout all zones and shall consist of at least 50% herbaceous material within Zone A. Wattles / Fascines should NOT be used in these locations unless otherwise directed by the Wetland Professional.
- All materials shall conform to the guidelines established by the American Association of Nurserymen as well as the technical and planting specifications specific to the plant condition.
- The Contractor shall hire an independent biologist or similarly qualified wetland professional to be on site to monitor construction of the wetland enhancement area to ensure compliance with the intent of the enhancement plan and construction documents.
- Woody species shall be arranged in groupings of no less than 7 plants. Herbaceous plants shall be used to fill gaps between groupings. Herbaceous plantings shall be spaced at 24" on center average and within Zone A only unless otherwise directed by the Wetland Professional.
- The Wetland Professional may adjust the planting zone boundaries and/or species if he/she determines that as-built site conditions would pose an unreasonable threat to the survival of plantings installed per the construction documents. The plantings shall be relocated to locations with suitable hydrology and soils and where appropriate structural context with other plantings can be maintained.
- Trees shown on the plan are approximate and should be field located within the allocated zone to provide satisfactory growing conditions.
- Plantings in Zone D shall be field located as required for optimal growing conditions. Areas designated as Zone D shall be seeded as noted in the Plantings Key.
- The Contractor shall assume responsibility to ensure that all work is performed in compliance with all State and Local requirements and permitting authorities.
- Contractor shall provide a watering plan for approval by the City. The plan should include weekly monitoring and/or watering during dry, hot weather. All plants and newly grassed areas shall be watered as required thereafter to ensure survival and growth through the first growing season or the end of the plant warranty period, whichever is longer.
- The Wetland Professional shall monitor / inspect restoration plantings twice per month, or as required to determine soil moisture levels, watering requirements, condition of irrigation system, as well as weeding and browse protection requirements.
- Wetland plantings, except as noted below, shall be considered successful if the cover of the wetland species is equal to 80% within the project planting area. If cover of the wetland species falls below 80% at the end of 1 year, the Wetland Professional shall determine if additional planting is required or if an additional growing season for existing plants will be required until the area has 80% coverage. The plant warranty shall remain in effect for the additional growing season. If coverage is less than 80% at the end of the second growing season, additional plantings shall be required and as specified by the wetland specialist.
- Woody plant material over 15-inches high at installation shall be guaranteed by the contractor for a period of one year from the date of installation. During the one year guarantee, the contractor shall replace, in kind, any dead, diseased, or substandard plant material at no cost to the owner. The contractor shall receive final acceptance from the owner following the one year guarantee, provided the provisions of the plant guarantee have been satisfactorily met.

PLANTING NOTES - CONTAINERIZED PLANTINGS

- Container plantings shall have a media and root volume of not less than 7 cubic inches. Volumes of 10 to 40 cubic inches are preferred. Properly aged and sized container plants should consist of enough fibrous root mass to retain the shape of the media when removed from the container. Container plants shall be at least 2 years old.
- All containers shall be removed at the time of planting only.
- Excavate a planting hole 1.5 times the diameter of the container and to the depth required. Each plant should be installed so that the top of the root ball is level with the grade of the surface grade. Place excavated soil next to hole for later use. Do not reuse unsuitable materials, including but not limited to rocks, debris or solid clay.
- Take a dull knife and run it vertically down the sides and bottom of the rootball making several shallow slits to loosen the roots. Gently spread roots by hand. Place plant planting hole to the planting site. All bare root stock sent from the storage facility shall be adequately protected from damage and covered with wet soil, sawdust, woodchips, moss, peat, straw, hay, or other acceptable moisture-holding medium.
- For woody, containerized plant material, mix suitable excavated soil with Superhumus (Casella Organics, Portland, ME) at a rate of 25% per volume or as required for optimal soil aggregation, improved porosity, permeability, aeration, drainage and rooting depth. Amendment application and rates should be confirmed via soil tests of the placed dredge material.
- Begin to refill the hole with prepared soil a little at a time, lightly compacting the soil every few inches around the root ball. Finishing filling hole with soil to the specified height contacting as you go.
- To the extent possible, create a 3-4 inch raised saucer at edge of the plant root zone to capture water.
- Place an organic based mulch around the plant to pre-determined standards (typical specification is a minimum of 2 inches deep and an area 24" wide centered on the plant). Water thoroughly.
- Stake containerized trees as directed by the wetland professional.

PLANT NOTES - BARE ROOT PLANTINGS

- Plants designated as bare root or collected plants shall conform to the American Standard for Nursery Stock.
- Bare root material shall not be dug or installed after bud break or before dormancy. Immediately after harvesting plants, protect from drying and damage until shipped and delivered to the planting site. All bare root stock sent from the storage facility shall be adequately protected from damage and covered with wet soil, sawdust, woodchips, moss, peat, straw, hay, or other acceptable moisture-holding medium.
- Plants must be protected at all times from sun or drying winds and shall be covered with a tarpaulin or canvas. Bare root material that cannot be planted immediately on delivery shall be kept in the shade, well protected with soil, wet mulch, or other acceptable material, and kept well watered. Plants shall not remain unplanted any longer than three days after delivery.
- Excavate a planting hole 1.5 times the diameter of the container and to the depth required. Each plant should be installed so that the top of the root ball is level with the grade of the surface grade. Place excavated soil next to hole for later use. Do not reuse unsuitable materials, including but not limited to rocks, debris or solid clay.
- Plants shall be dug and handled with suitable support of the soil ball to avoid damaging it.
- The roots of bare-root trees shall be pruned at the time of planting to remove damaged or undesirable roots (those likely to become a detriment to future growth of the root system).
- Bare-root trees shall have the roots spread to approximate the natural position of the roots and shall be centered in the planting pit on a firmly packed mound of prepared soil. Determine the elevation of the root flare and ensure that it is planted at grade.
- Hold the plant's trunk and work planting-soil backfill firmly into and around the roots, with care taken to fill in completely with no air pockets.
- Water plant thoroughly.
- Place an organic based mulch around the plant to pre-determined standards (typical specification is a minimum of 2 inches deep and an area 24" wide centered on the plant).

PLANTING NOTES - LIVE STAKES

- The live stakes shall be from native woody plant materials or woody plant materials adapted to the site. The plant species and dimensions are shown on the drawings. The plant material shall be free from disease and harmful insects. The plant materials shall be installed within 48 hours after initial preparation unless refrigerated.
- Cut stakes form long, upright branches taken off the parent plant. Only take cuttings from plants where landowner permission is obtained and the cutting will not unduly impact the health of parent plants. Cuttings must not be allowed to dry out and must be kept covered and moist during transport and storage.
- Remove leaves and side branches from cuttings and do not use the first year growth. The basal ends should be cut at an angle and the top cut square. Live stakes should be between 18 and 24 inches long and at least three-eighths of an inch in diameter.
- Make a straight cut at the narrow end of the stake (toward the tip of the branch). At the thicker end (toward the trunk) cut the branch at an angle to make a point that can be driven into the ground.
- Dip the top (blunt cut, narrow end) 2-3 inches of the stakes in latex paint immediately after they are cut. Use the paint to mark correct planting end, seal the exposed cut and helps prevent drying and cracking. You can also use different colors of paint to color code different species of cuttings, planting times, and other treatments. The paint will also make the stakes visible in the field.
- Plant live stakes within 24 hours for best results. In the meantime, keep them moist and wet in buckets or wet burlap sacks. On hot days, keep them in the shade until you plant them.
- Soak or dip the bottom ends of cuttings in a solution of plant rooting hormone before planting to speed up growth. The willows and red osier dogwood species do not require rooting hormone.
- Drive the stakes into the bank or wetland soil at least one foot deep (the deeper the better) using a rubber mallet. Use a planting bar or length of rebar to start the hole in hard soils. Leave three to six inches above ground surface so they can sprout leaves.
- Use longer stakes and leave one-foot sticking above the ground if the stake will be shaded by surrounding vegetation.
- Retain the stakes to use to fill gaps in wetter soils as directed by the wetland specialist. Store and plant as described herein.

PERMIT REVIEW SET - NOT FOR CONSTRUCTION

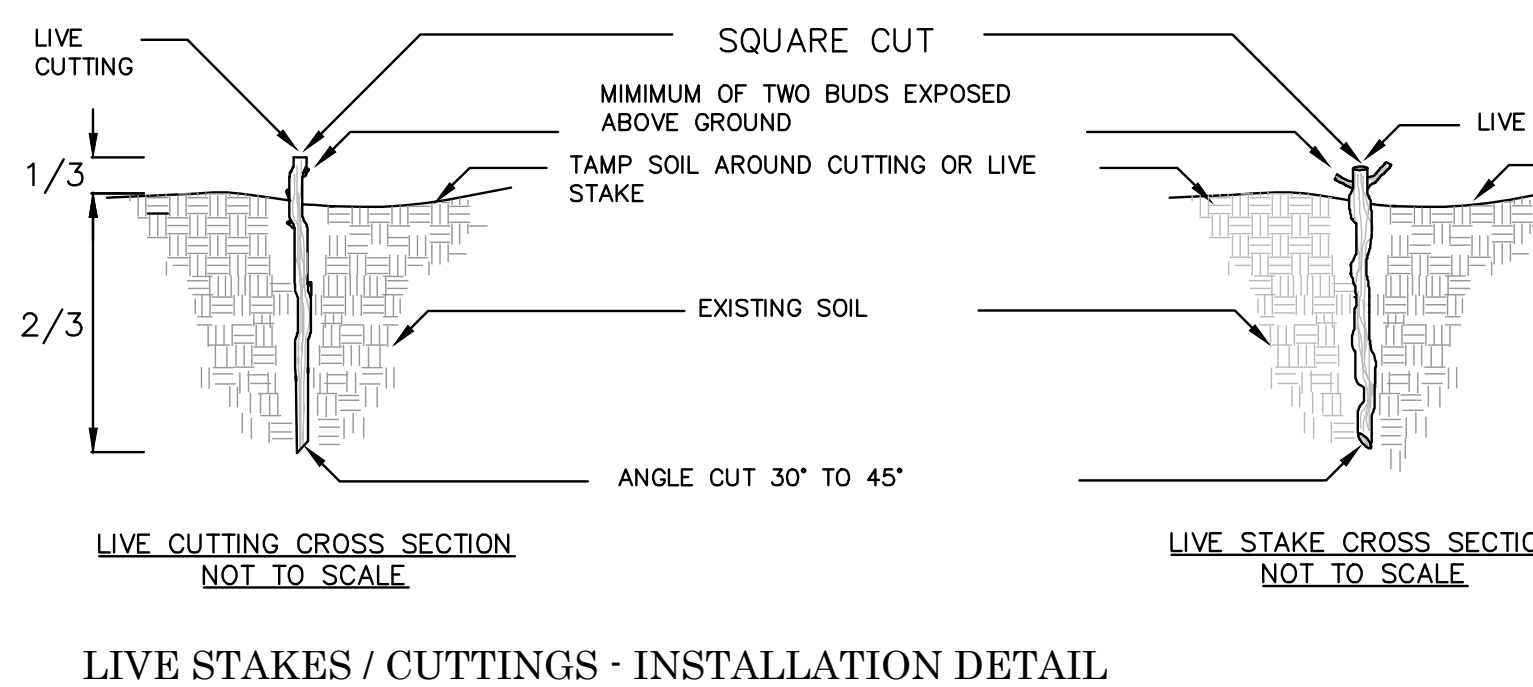

LIVE STAKES / CUTTINGS - INSTALLATION DETAIL

WETLAND PLANTINGS			WETLAND PLANTINGS		
GENUS/SPECIES/CULTIVAR	COMMON NAME	SIZE/CONDITION NOTES	GENUS/SPECIES/CULTIVAR	COMMON NAME	SIZE/CONDITION NOTES
ZONE A (OBL)			ZONE D (FAC)		
CEPHALANTHUS OCCIDENTALIS	BUTTONBUSH	LS/T 3-5' OC	ARONIA ARBUTIFOLIA	RED CHOKEBERRY	POT, #1 B 5' OC MIN
CORNUS SERICEA	RED TWIG DOGWOOD	LS/T 3-5' OC	CORNUS AMOMUM	SILKY DOGWOOD	POT, #1 B 5' OC MIN
ILEX MICROCALLATA	MOUNTAIN HOLLY	C 3-5' OC	CORNUS SERICEA	RED TWIG DOGWOOD	LS/T 3-5' OC
RHOODRA VISCOSUM	SWAMP AZALEA	C 3-5' OC	ILEX VERTICILLATA	WINTERBERRY	BR 3-5' OC
SAUX PETIOLARIS	SLENDER WILLOW	C 3-5' OC	SAUX DISCOLOR	PUSSYWILLOW	LS/T 3-5' OC
HERBACEOUS:			SAMBUCUS CANADENSIS	AMERICAN ELDERBERRY	T 3-5' OC
CAREX VULPINOIDES	FOX SEDGE	2" PEAT POT 18-24" OC	VIBURNUM DENTATUM	ARROWWOOD VIBURNUM	BR 5' OC MIN
SORRIPUS ATROVIRENS	GREEN BULRUSH	2" PEAT POT 18-24" OC			
SORRIPUS CYPHERINUS	WOOLGRASS	BR/PLUG			
ZONE B (FACW)			SEED:		
ALNUS INCANA	SPECKLED ALDER	C 5' OC MIN	NEW ENGLAND CONSERVATION / WILDLIFE MIX		
CORNUS SERICEA	RED TWIG DOGWOOD	LS/T 3-5' OC	APPLICATION RATE: 25 LBS/ACRE (X2) - SPRING SEEDING (FALL)		
ILEX VERTICILLATA	WINTERBERRY	BR 5' OC MIN			
SAUX DISCOLOR	PUSSYWILLOW	LS/T 3-5' OC	NEW ENGLAND WETLAND PLANTS, INC.		
SAMBUCUS CANADENSIS	AMERICAN ELDERBERRY	T 3-5' OC	600 WEST STREET, AMHERST, MA 01002		
			TEL. 413-548-8000		

PLANTING AREAS (APPROX.):		PLANT QUANTITIES BY CONDITION / SIZE (FOR PRICING):	
ALL ZONES:	2.4 ACRES (APPROX.)	29	TREES (8B, 5-6")
ZONES A-C:	1.3 ACRES (APPROX.)	11	TREES (#7 POT)
ZONE D:	1.1 ACRES (APPROX.)	9	TREES (#5 POT)
		9	TREES (#3 POT)
		1,015	SHRUBS (T/C/L/S)
		235	SHRUBS (#1 POT)
		332	SHRUBS (BR/12-18")
		1,552	HERBACEOUS (BR/PLUG/2" PEAT POT)

NOTES:
 1. ALL TREES AND SHRUBS TO BE FIELD-LOCATED; REFERENCE PLAN AND PLANTING NOTES FOR GUIDANCE.
 2. THIS LIST IS PROVIDED FOR GUIDANCE AND PRICING. THE PLANTING PLAN SHOULD BE RE-EVALUATED AND ADJUSTED AS REQUIRED AT THE TIME OF PLANTING AND FOLLOWING THE POND EXCAVATION AND REGRADING WORK TO RESPOND TO AS-BUILT GROWING CONDITIONS AND AVAILABILITY FROM LOCAL SOURCES AT THE TIME OF PLANTING.

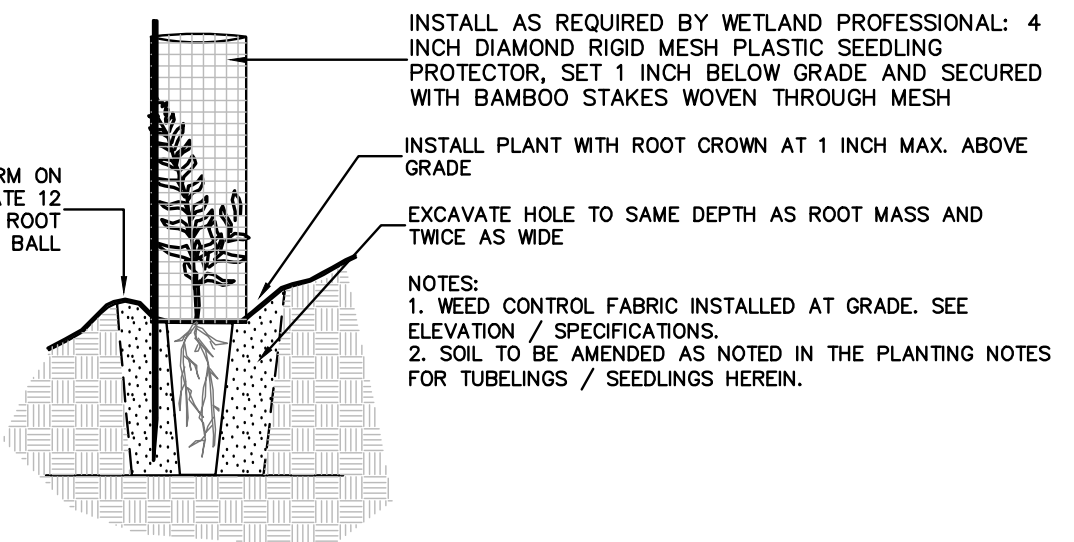

TUBELING / SEEDLING - INSTALLATION DETAIL

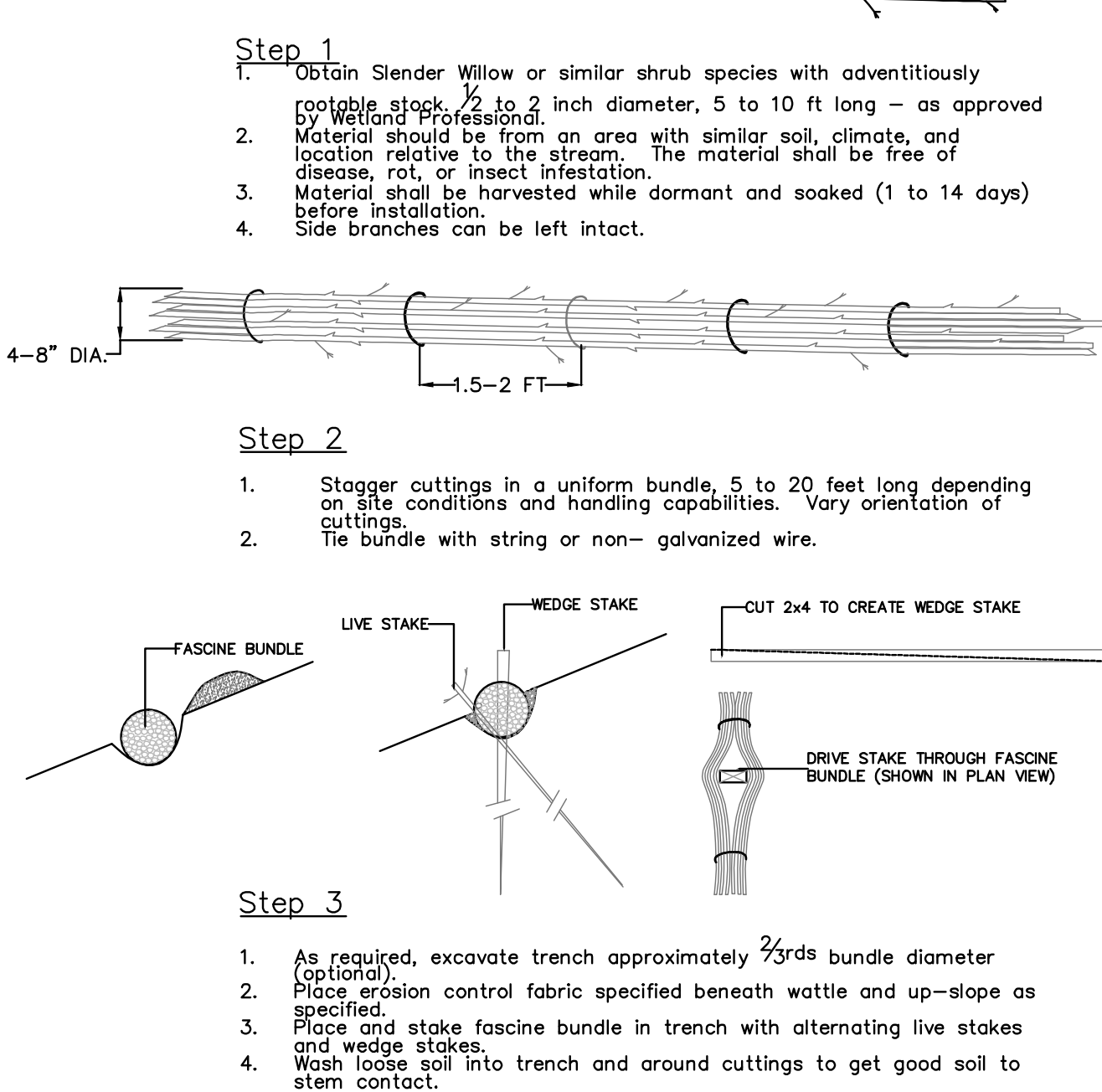

WATTLES / FASCINES - INSTALLATION DETAIL

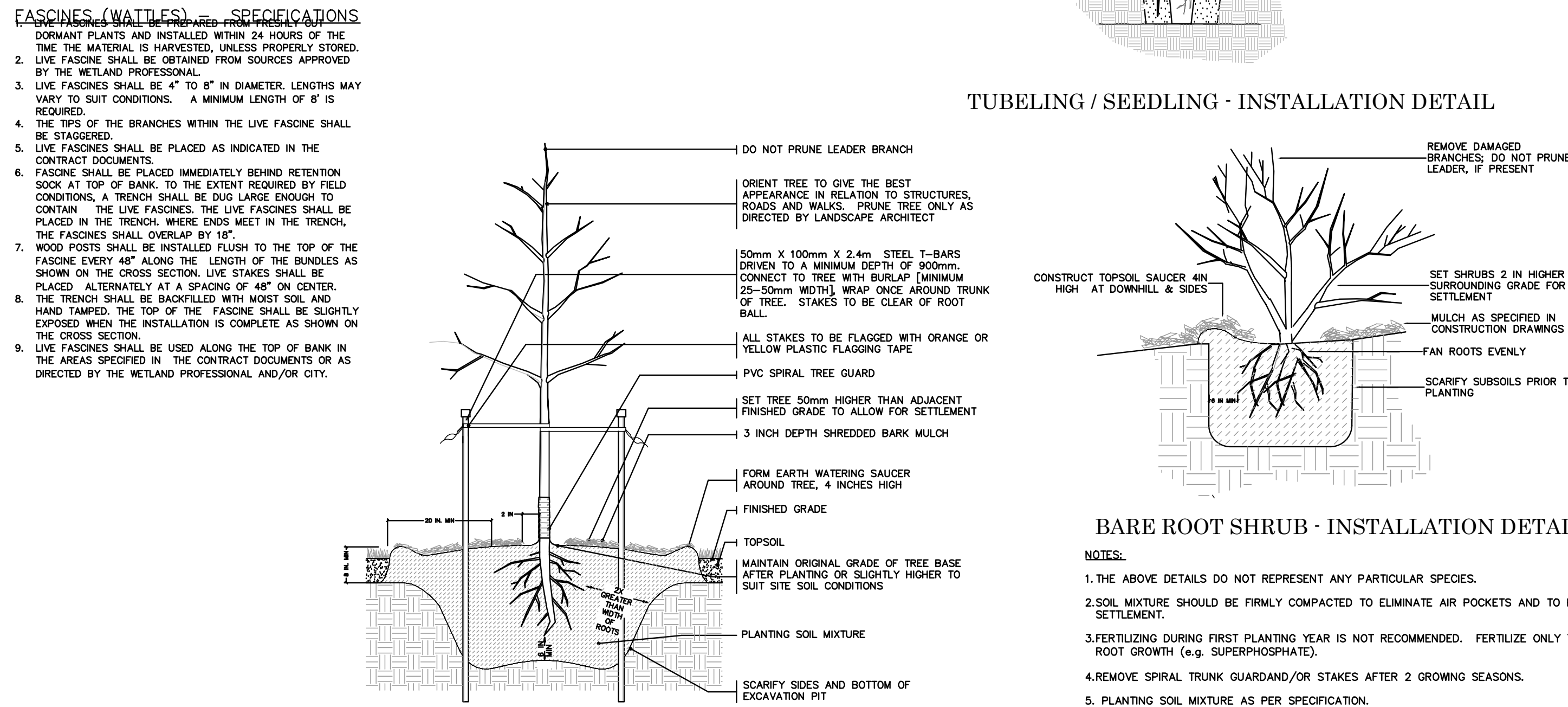

BARE ROOT TREE - INSTALLATION DETAIL

41 Hutchins Drive
 Portland, Maine 04102
 800.426.4262 | www.woodardandcurran.com

WOODARD & CURRAN
 COMMITMENT & INTEGRITY DRIVE RESULTS

DATE: DECEMBER 2013
 SCALE: AS NOTED
 SHEET: 7 OF 9

Regina S. Leonard
 landscape architecture & design
 29 Bridge Street
 Topsham, Me 04086
 Tel. 207.450.9700
 Regina@reginaledesign.com

CITY OF PORTLAND, PORTLAND, MAINE
CAPISIC POND ENHANCEMENTS

JOB NO: 225672.15
 DATE: DECEMBER 2013
 SCALE: AS NOTED
 SHEET: 7 OF 9

C-201