

City of Portland, Maine - Building or Use Permit Application

389 Congress Street, 04101 Tel: (207) 874-8703, Fax: (207) 874-8716

Permit No: 09-1289	Issue Date:	CBL: 191 B044001
-----------------------	-------------	---------------------

Location of Construction: 28 Willow Ln	Owner Name: Thibodeau Laura D	Owner Address: 28 Willow Ln	Phone:
Business Name:	Contractor Name: Frost N Flame/Eastern Shed Co	Contractor Address: 629 Main St. Gorham 04038	Phone 2078567000
Lessee/Buyer's Name	Phone:	Permit Type: HVAC	Zone: R-5 PRUD

Past Use: <i>Single Family Dwelling</i>	Proposed Use: Install a gas fireplace with a direct vent.	Permit Fee: \$50.00	Cost of Work: \$2,400.00	CEO District: 3	INSPECTION: Use Group: <i>R3</i> Type: <i>SB</i> <i>JRC 2003</i>
		FIRE DEPT: <input type="checkbox"/> Approved <input type="checkbox"/> Denied		Signature: <i>Jm 11/20/09</i>	

Proposed Project Description: Install a gas fireplace with a direct vent.	PEDESTRIAN ACTIVITIES DISTRICT (P.A.D.) Action: <input type="checkbox"/> Approved <input type="checkbox"/> Approved w/Conditions <input type="checkbox"/> Denied Signature: _____ Date: _____
--	---

Permit Taken By: jmy	Date Applied For: 11/12/2009	Zoning Approval
-------------------------	---------------------------------	------------------------

<ol style="list-style-type: none"> This permit application does not preclude the Applicant(s) from meeting applicable State and Federal Rules. Building permits do not include plumbing, septic or electrical work. Building permits are void if work is not started within six (6) months of the date of issuance. False information may invalidate a building permit and stop all work.. 	Special Zone or Reviews <input type="checkbox"/> Shoreland <input type="checkbox"/> Wetland <input type="checkbox"/> Flood Zone <input type="checkbox"/> Subdivision <input type="checkbox"/> Site Plan Maj <input type="checkbox"/> Minor <input type="checkbox"/> MM <input type="checkbox"/> Date: <i>11/17/09</i>	Zoning Appeal <input type="checkbox"/> Variance <input type="checkbox"/> Miscellaneous <input type="checkbox"/> Conditional Use <input type="checkbox"/> Interpretation <input type="checkbox"/> Approved <input type="checkbox"/> Denied Date: _____	Historic Preservation <input checked="" type="checkbox"/> Not in District or Landmark <input type="checkbox"/> Does Not Require Review <input type="checkbox"/> Requires Review <input type="checkbox"/> Approved <input type="checkbox"/> Approved w/Conditions <input type="checkbox"/> Denied Date: _____
---	---	---	--

CERTIFICATION

I hereby certify that I am the owner of record of the named property, or that the proposed work is authorized by the owner of record and that I have been authorized by the owner to make this application as his authorized agent and I agree to conform to all applicable laws of this jurisdiction. In addition, if a permit for work described in the application is issued, I certify that the code official's authorized representative shall have the authority to enter all areas covered by such permit at any reasonable hour to enforce the provision of the code(s) applicable to such permit.

PERMIT ISSUED

SIGNATURE OF APPLICANT	ADDRESS	DATE NOV 20 2009	PHONE
RESPONSIBLE PERSON IN CHARGE OF WORK, TITLE		DATE	PHONE City of Portland

City of Portland, Maine - Building or Use Permit

389 Congress Street, 04101 Tel: (207) 874-8703, Fax: (207) 874-8716

Permit No: 09-1289	Date Applied For: 11/12/2009	CBL: 191 B044001
------------------------------	--	----------------------------

Location of Construction: 28 Willow Ln	Owner Name: Thibodeau Laura D	Owner Address: 28 Willow Ln	Phone:
Business Name:	Contractor Name: Frost N Flame/Eastern Shed Co	Contractor Address: 629 Main St. Gorham	Phone (207) 856-7000
Lessee/Buyer's Name	Phone:	Permit Type: HVAC	

Proposed Use: Install a gas fireplace with a direct vent.	Proposed Project Description: Install a gas fireplace with a direct vent.
---	---

Dept: Zoning	Status: Approved with Conditions	Reviewer: Marge Schmuckal	Approval Date: 11/17/2009
Note:	Ok to Issue: <input checked="" type="checkbox"/>		
<ol style="list-style-type: none"> 1) This is NOT an approval for an additional dwelling unit. You SHALL NOT add any additional kitchen equipment including, but not limited to items such as stoves, microwaves, refrigerators, or kitchen sinks, etc. Without special approvals. 2) This property shall remain a single family dwelling. Any change of use shall require a separate permit application for review and approval. 			
Dept: Building	Status: Approved with Conditions	Reviewer: Tom Markley	Approval Date: 11/20/2009
Note:	Ok to Issue: <input checked="" type="checkbox"/>		
<ol style="list-style-type: none"> 1) The installation must comply with the State of Maine Gas Regulations. 2) Application approval based upon information provided by applicant. Any deviation from approved plans requires separate review and approval prior to work. 			

PERMIT ISSUED

NOV 20 2009

City of Portland

BUILDING PERMIT INSPECTION PROCEDURES

Please call 874-8703 or 874-8693 (ONLY)

to schedule your inspections as agreed upon

Permits expire in 6 months, if the project is not started or ceases for 6 months.

The Owner or their designee is required to notify the inspections office for the following inspections and provide adequate notice. Notice must be called in 48-72 hours in advance in order to schedule an inspection:

By initializing at each inspection time, you are agreeing that you understand the inspection procedure and additional fees from a "Stop Work Order" and "Stop Work Order Release" will be incurred if the procedure is not followed as stated below.

A Pre-construction Meeting will take place upon receipt of your building permit.

 X Final inspection required at completion of work.

Certificate of Occupancy is not required for certain projects. Your inspector can advise you if your project requires a Certificate of Occupancy. All projects DO require a final inspection.

If any of the inspections do not occur, the project cannot go on to the next phase, REGARDLESS OF THE NOTICE OR CIRCUMSTANCES.

CERIFICATE OF OCCUPANICES MUST BE ISSUED AND PAID FOR, BEFORE THE SPACE MAY BE OCCUPIED.

Signature of Applicant/Designee

John M. Marbley

Signature of Inspections Official

Date

11/20/09

Date

PERMIT ISSUED

NOV 20 2009

City of Portland



FILL IN AND SIGN WITH INK

PERMIT ISSUED

APPLICATION FOR PERMIT HEATING OR POWER EQUIPMENT

NOV 20 2009

City of Portland
191-B-044001

To the INSPECTOR OF BUILDINGS, PORTLAND, ME.

The undersigned hereby applies for a permit to install the following heating, cooking or power equipment in accordance with the Laws of Maine, the Building Code of the City of Portland, and the following specifications:

Location / CBL PORTLAND Use of Building HOME Date _____

Name and address of owner of appliance 28 WILLOW LN

Installer's name and address FROST + FLAME 629 MAIN ST GORHAM

Telephone _____

Location of appliance:

- Basement
- Floor
- Attic
- Roof

Type of Fuel:

- Gas
- Oil
- Solid

Appliance Name: JOTUL LILTE HAMMER

U.L. Approved Yes No

Will appliance be installed in accordance with the manufacture's installation instructions? Yes No

IF NO Explain: _____

The Type of License of Installer:

- Master Plumber # _____
- Solid Fuel # _____
- Oil # _____
- Gas # PNT 5578
- Other _____

Type of Chimney:

Masonry Lined
Factory built _____

Metal
Factory Built U.L. Listing # _____

Direct Vent
Type _____ UL# _____

Type of Fuel Tank

- Oil
- Gas

Size of Tank _____

Number of Tanks _____

Distance from Tank to Center of Flame _____ feet.

Cost of Work: \$ 2400.00

Permit Fee: \$ 50

RECEIVED

NOV 12 2009

Dept. of Building Inspections
City of Portland Maine

Approved

Approved with Conditions

Fire: _____

Ele.: _____

Bldg.: _____

See attached letter or requirement

Inspector's Signature

Date Approved

Signature of Installer M. O. [Signature]

SEBAGO LAKE POOLS/ROYAL IMPROVEMENTS, INC.
FROST N' FLAME, INC.

621 Main St.
 Gorham, ME 04038
 856-1000 856-7000

889 Roosevelt Trail
 N. Windham, ME 04062
 893-3483 893-2876

Fax 856-1164

www.frostandflame.com www.sebagolakepools.com

To: LAURA THIBODEAN
28 WILLOW LN. Town: PORTLAND
 State: ME Zip Code: 04102

Directions: RT. 25 TO STROUDWATER ST. IN W.B. TURN (R) TO CONGRESS ST.,
 FOLLOW INTO PORTLAND, (R) ONTO LASSELL ST. - TURNS INTO WILLOW LN.,
 HOUSE ON (R), SHINGLES (GRAY) FACING CTR. CIRCLE.

(4m) 10/17 ~~10/17~~ ~~10/17~~ ~~10/17~~ ~~10/17~~

JOB INVOICE

HOME PHONE (X) 318-1948
 CELL # ~~1120 Brian~~ 4-22 Brian
 WK PHONE
 DATE OF ORDER 11-24 ORDER TAKEN BY Aaron
 CONTRACTOR License # 5578
 PHONE # FAX #
 MAILING ADDRESS OR E-MAIL dt-65@hotmail.com

QTY.	MATERIALS	PRICE	AMOUNT	DESCRIPTION OF WORK/LOCATION
①	JOTUL LILLEHAMMER GAS STOVE - # 350837 REG. \$1,965.00			
	- SALE.		\$1,865.00	
1	Majolica Brown enamel Regular 1,965.00 Sale price		\$1,865.00	Down thru Floor to garage area across ceiling to basement connect to existing line
1	Screen # 155641		85.00	
1	on/off Remote (special)		65.00	
1	Hearth pad (customer will pick out color) P/U 10/26		\$245.00	
	COVER UNIT OUTSIDE MATERIALS TO VENT		\$475.00	
TOTAL MATERIALS				\$2,490.00

GAS LINE INSTALLATION		QUOTE
COST OF ANY PROPANE NOT INCLUDED		
NATURAL GAS		
QUOTE HOOK-UP (yes)		
Black Iron	→ GAS LINE MATERIALS	195.00
	→ GAS LINE LABOR	165.00
REGULATOR & GAS TANK PROPERTY OF WEBBER ENERGY		
LABOR	HRS.	RATE
DELIVER, INSTALL, & VENT UNIT		\$
		345.00
COST OF PERMIT IF REQUIRED		
SHIPPING COST		
JOB LABOR		345.00
MATERIALS		2490.00
MATERIALS FOR GAS LINE		195.00
GAS LINE LABOR		165.00
TAX		34.25
TOTAL		329.25

20% Restocking Fee for ANY returned or cancelled materials!

I, the customer, have read the back of this contract for terms & conditions of sale, and have signed the back page.

Work ordered by Signature Laura Thibodean
 I hereby acknowledge the satisfactory completion of the above described work

Thank You



GF 200 DV Lillehammer Gas Heater

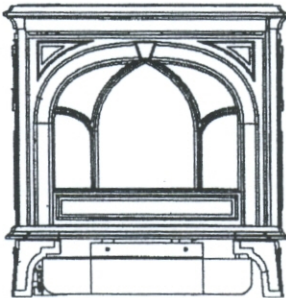

Installation
and
Operation
Instructions



WARNING:

IF THE INFORMATION IN THESE INSTRUCTIONS ARE NOT FOLLOWED EXACTLY, A FIRE OR EXPLOSION MAY RESULT CAUSING PROPERTY DAMAGE, PERSONAL INJURY OR LOSS OF LIFE.

FOR YOUR SAFETY:

DO NOT STORE OR USE GASOLINE OR OTHER FLAMMABLE VAPORS AND LIQUIDS IN THE VICINITY OF THIS OR ANY OTHER APPLIANCE.

INSTALLATION:

INSTALLATION AND SERVICE MUST BE PERFORMED BY A QUALIFIED INSTALLER, SERVICE AGENCY OR LICENSED GAS SUPPLIER.

WHAT TO DO IF YOU SMELL GAS:

- DO NOT TRY TO LIGHT ANY APPLIANCE.
- DO NOT TOUCH ANY ELECTRICAL SWITCHES.
- DO NOT USE THE PHONE IN YOUR BUILDING. IMMEDIATELY CALL YOUR GAS SUPPLIER FROM A NEIGHBOR'S PHONE.
- FOLLOW YOUR GAS SUPPLIER'S INSTRUCTIONS.
- IF YOU CANNOT REACH YOUR GAS SUPPLIER, CALL THE FIRE DEPARTMENT.

AVERTISSEMENT:

ASSUREZ-VOUS DE BIEN SUIVRE LES INSTRUCTIONS DANS CETTE NOTICE POUR REDUIRE AU MINIMUM LE RISQUE D'INCENDIE OU POUR EVITER TOUT DOMMAGE MATERIEL, TOUTE BLESSURE OU MORTALITE.

NE PAS ENTREPOSER NI UTILISER D'ESSENCE NI OU LIQUIDES INFLAMMABLES DANS LE VOISINAGE DE CET APPAREIL OU DE TOUT AUTRE APPAREIL.

L'INSTALLATION LE SERVICE DOIVENT ETRE EXECUTES PAR UN INSTALLATEUR QUALIFIE, AGENCE DE SERVICE OU LE FOURNISSEUR DE GAZ.

QUE FAIRE SI VOUS SENTEZ UNE ODEUR DE GAZ.

- NE PAS TENTER D'ALLUMER L'APPAREIL
- NE TOUCHEZ A AUCUN INTERRUPTEUR.
- NE PAS VOUS SERVIR DES TELEPHONES SE TROUVANT DANS LE BATIMENT OU VOUS VOUS TROUVEZ.
- APPELEZ IMMEDIATEMENT VOTRE FOURNISSEUR DE GAZ CHEZ UN VOISIN. SUIVEZ LES INSTRUCTIONS DU FOURNISSEUR.
- SI VOUS NE POUVEZ REJOINDRE LE FOURNISSEUR DE GAZ, APPELEZ LE SERVICE DES INCENDIES.

Jøtul GF 200 DV Lillehammer Specifications

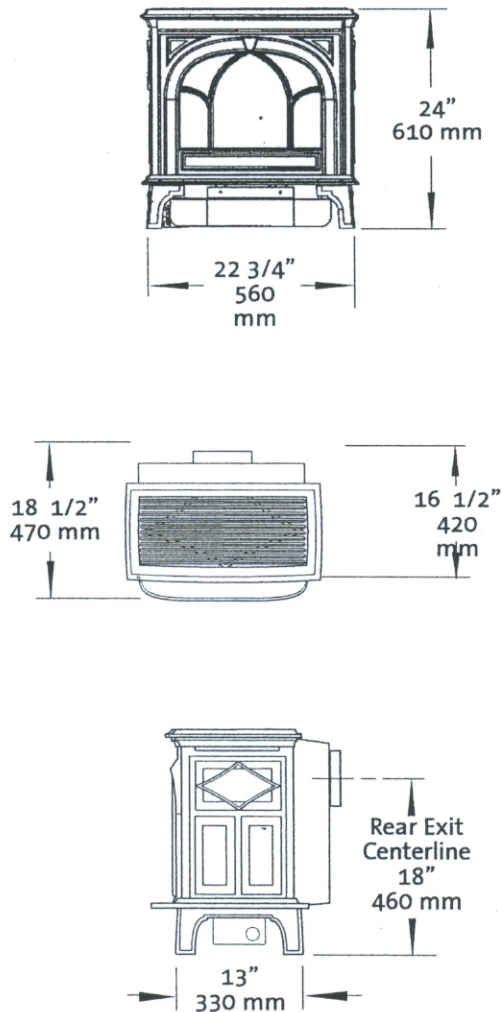

Figure 1. Dimensional Views - GF 200 DV Lillehammer

Input Rates

Natural Gas

18,000 BTU/hr. maximum input
13,500 BTU/hr. minimum input

Propane

18,000 BTU/hr. maximum input
13,500 BTU/hr. minimum input

Inlet Pressure: MIN MAX

Natural Gas: 5.0 WC (1.24 kPa) 7.0 WC (1.74 kPa)
Propane: 11.0 WC (2.73 kPa) 13.5 WC (3.36 kPa)

Manifold Pressure: MIN MAX

Natural Gas: 2.2 WC (.54 kPa) 3.5 WC (.87 kPa)
Propane: 6.5 WC (1.61 kPa) 10.0 WC (2.49 kPa)

Efficiency: 82%

Steady State (A.F.U.E.): 73%

Piezo Ignitor / Standing Pilot

The Jøtul GF 200 DV Lillehammer is a Direct Vent wall furnace designed as a sealed combustion, air circulating gas appliance for residential applications. This appliance is approved for installation using 6/8" X 4" vent pipe from the following manufacturers:

Simpson Dura-Vent GS
Security Vent, Ltd.
Amerivent Inc.

The Jøtul Lillehammer gas stove is designed to burn NATURAL GAS or PROPANE only. It is shipped from the factory equipped to burn Natural Gas. If use with Propane is desired, the stove must first be converted for use with that gas. Use the LP Fuel Conversion Kit included with this stove See page 15.

GF 200 DV Lillehammer Options

- Fuel Conversion Kit - NG..... 155349
- Fuel Conversion Kit - LP 155350
- High Altitude Conversion Kit - NG 154371
- High Altitude Conversion Kit - LP 154373
- Wall Thermostat 750003
- Remote Control 129706
- Mobile Home Floor Bracket Kit 154342

Safety Information

The Jøtul GF 200 Lillehammer gas stove during normal operation, will reach high surface temperatures. Read and follow the safety guidelines below.

- Due to the high operating temperatures, this appliance should be located out of traffic and away from furniture and draperies.
- Children and adults should be alerted to the hazards of high surface temperatures and should stay away to avoid burns or clothing ignition.
- Young children should be supervised while they are in the same room as the Lillehammer gas stove.
- Clothing or other flammable materials should not be placed ON or NEAR the Lillehammer gas stove. Surveiller les enfants. Garder les vêtements, les meubles, l'essence ou autres liquides à vapeur inflammables loin de l'appareil.
- NEVER store or use gasoline or any other flammable vapors or liquids in the vicinity of the Lillehammer gas stove.
- Never burn any other materials in your Lillehammer gas stove, it is strictly designed for use with natural gas or propane fuel ONLY.
- Any safety screen, glass or guard removed for servicing the appliance must be replaced prior to operating the appliance.

Locating the Stove

In selecting the location, the aesthetic and functional use of the appliance are primary concerns. However, proper venting systems and access to the fuel supply are also important issues. Due to the high surface temperatures of the Lillehammer, one must also consider the proximity of traffic ways, furniture, draperies, etc.

This appliance may be located on or near conventional construction materials. HOWEVER, always maintain the proper clearances to combustibles, as this provides adequate ventilation air around the appliance.

The following clearances and hearth requirements are the minimum requirements when installing the Lillehammer gas stove near or on combustible surfaces. Always provide adequate access around the appliance for servicing and proper operation.

A combustible surface is anything that can burn (i.e. sheet rock, wall paper, wood, fabrics etc.). These surfaces are not limited to those that are visible and also include materials that are behind non-combustibles.

If you are not sure of the combustible nature of a material, consult your local fire officials. Remember, "Fire Resistant" materials are considered combustible: they are difficult to ignite, but will burn. Also, "fire-rated" sheet rock is considered combustible.

Hearth Requirements

The Jøtul GF 200 Lillehammer gas stove CANNOT be installed directly on carpeting, vinyl flooring, Pergo®, or linoleum. If it is desired to install this appliance on any combustible material OTHER THAN WOOD, a floor pad must be installed that is either metal, wood or a listed hearth pad. This floor protection must extend the full width and depth of the appliance. It is not necessary to remove the carpeting, vinyl or linoleum from underneath the floor protection.

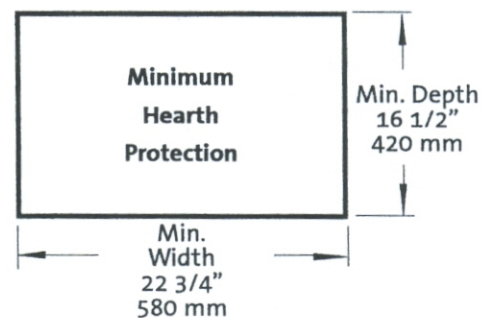

Figure 2. Lillehammer Hearth Protection

Clearance to Combustibles

Minimum Stove Clearance

Rear	0"	(0mm)
Ceiling	17"	(432mm)
Corner	2"	(51mm)
Right Side	2"	(51mm)
Left Side	*10"	(255mm)

* Necessary for complete access to pull out required Lighting Instructions Plate.

Minimum Vent Pipe Clearance

Horizontal runs:

Off the top of the pipe -	2"	(26mm)
Off the sides and bottom -	1"	(26mm)

Vertical runs:

All sides -	1"	(26mm)
-------------	----	--------

See Figures 4 and 5.

Mantel and Trim Clearances

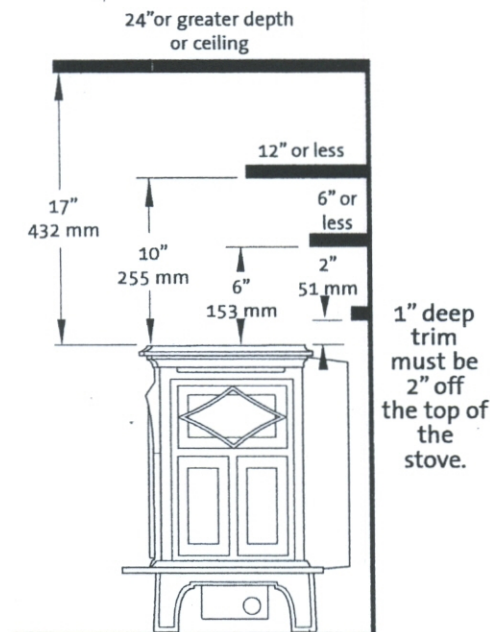
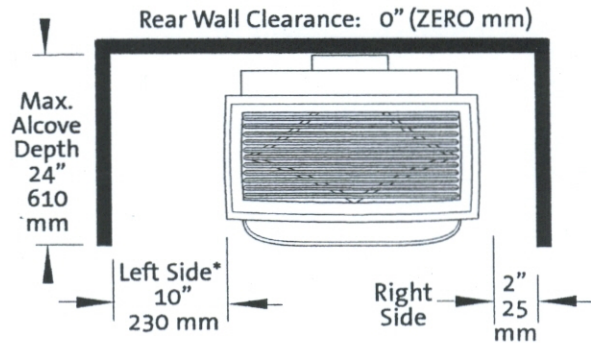

Figure 3. Mantel / Trim Clearances

Parallel Installation



* Allow 10" on left side of the appliance for complete access to the lighting instructions and control valve.

Figure 4. Clearances with stove parallel to the walls

Alcove Installation

Maximum Depth:	24"	(610mm)
Minimum Width:	35"	(890mm)
Minimum Ceiling Height:	42"	(1067mm)

Corner Installation

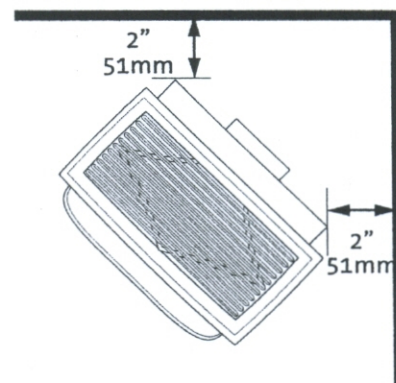

Figure 5. Clearance to rear corners.

Co-linear Hearthmount Installation

The Jøtul GF 200 DV Lillehammer may be vented through a masonry fireplace using Simpson Dura-Vent Chimney Liner Conversion Kit 923GK. When installed in the manner described below, this system can improve the performance of the appliance in cold climate situations, as well as simplify the vent installation.

These guidelines must be followed:

1. Prior to the installation, the chimney flue must be thoroughly cleaned and inspected by a qualified chimney service person.
2. In a masonry chimney, a fireclay liner or listed steel liner, must be present the entire length of the chimney.
3. No appliance can be installed into a chimney flue serving any other appliance of any kind.
4. The minimum length of the **AIR INTAKE FLEX** is **6 feet- measured off of the back of the appliance** and **IT MUST EXTEND PAST THE DAMPER AREA OF THE FIREPLACE.**
5. If the intake flex does not extend the full length of the chimney and connect to both the unit and the termination cap, A **METAL BLOCK OFF PLATE** MUST BE CONSTRUCTED AND INSTALLED ABOVE THE UNIT PRIOR TO THE END OF THE INTAKE FLEX AND MUST COMPLETELY SEAL THE CHIMNEY FLUE FROM THE ROOM.

Consult with the local code authority having jurisdiction before proceeding with this type of installation.

Refer to the vent manufacturer's instructions for specific installation requirements.

WARNING: FAILURE TO POSITION THE PARTS AND STOVE IN ACCORDANCE WITH THESE DIAGRAMS OR FAILURE TO USE ONLY PARTS SPECIFICALLY APPROVED FOR USE WITH THIS APPLIANCE MAY RESULT IN PROPERTY DAMAGE OR PERSONAL INJURY. BE SURE TO MAINTAIN THE PROPER CLEARANCES TO COMBUSTIBLES AS DEFINED IN THIS MANUAL AND INM THE INSTRUCTIONS PROVIDED WITH EACH VENT COMPONENT.

IMPORTANT NOTICE

THE USE OF AN EXISTING CHIMNEY AS AN AIR INTAKE IS NOT COVERED UNDER THE ANSI Z21.88-1999-CSA 2.33-M99 TEST METHODS AND RESULTING ITS/WHI PRODUCT CERTIFICATION. THE CODE AUTHORITY HAVING JURISDICTION MUST BE CONSULTED PRIOR TO PROCEEDING WITH THIS INSTALLATION

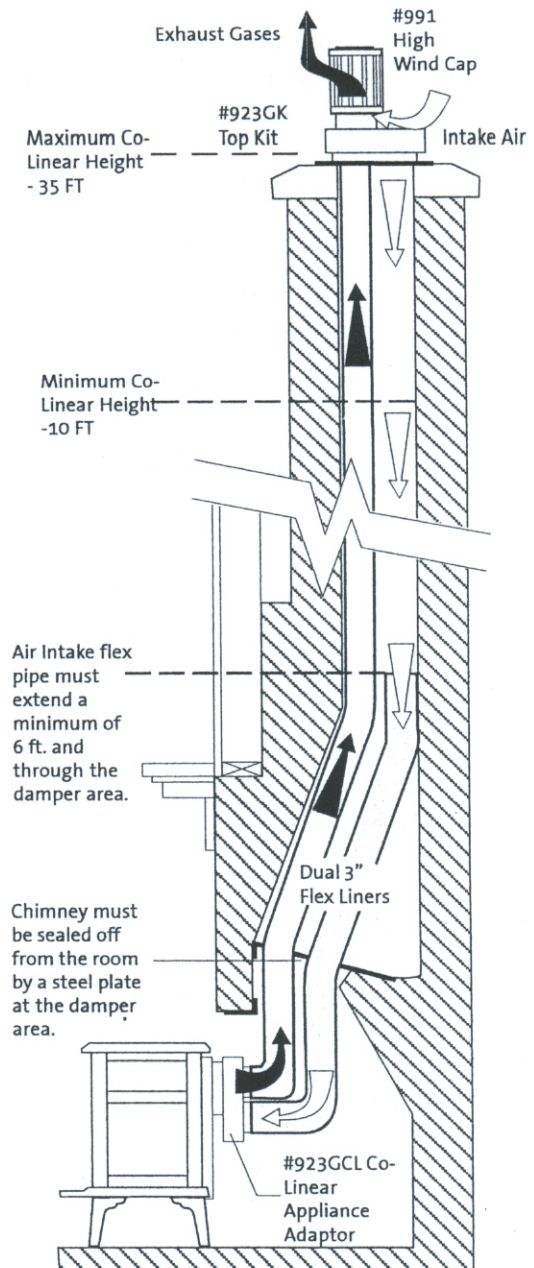

Figure 8. Co-Linear Vent System installed in a masonry fireplace.

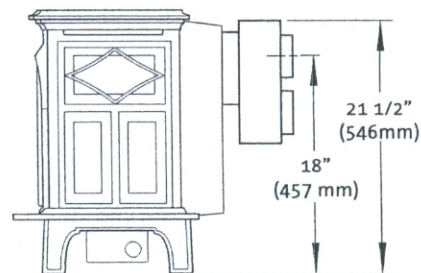

Figure 9. Co-Linear Adaptor dimensions with Plinth legs.

Masonry or Prefabricated Chimney Conversion

The GF200 DV Lillehammer is approved for use with Simpson Dura-vent Chimney Kit #934 in a masonry chimney or a prefabricated solid fuel listed chimney. These installation requirements must be followed:

1. In masonry chimney, a fireclay liner or listed steel liner, must be present the entire length of the chimney.
2. The liner must have an inside dimension of 6" round or greater. (USE KIT #934)
3. Prefabricated chimneys must be UL 103 or ULC S-629 listed and have a minimum INSIDE diameter of 6 inches, (150 mm). Prefabricated chimneys must be listed for the specific Simpson Dura-Vent Chimney Conversion Kit. (USE KIT #931, #932, or #933)
4. The Exhaust Restrictor plate, shipped with the stove, must be installed according to the instructions on page 8.

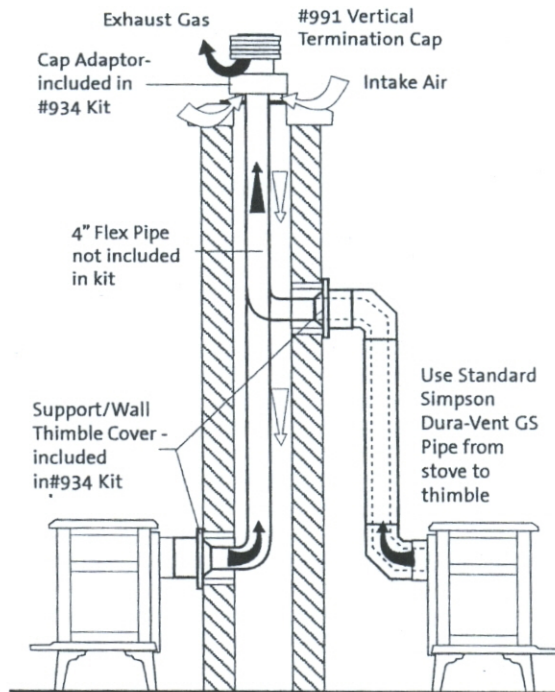

Figure 10. Vent System through a masonry chimney using the Simpson Dura-Vent Chimney Conversion Kit #934. May also be used in listed prefabricated chimneys. Drawing is for illustrative purposes only - **DO NOT VENT TWO APPLIANCES INTO A SINGLE CHIMNEY.**

IMPORTANT NOTICE

THE USE OF AN EXISTING CHIMNEY AS AN AIR INTAKE IS NOT COVERED UNDER THE ANSI Z21.88-1999-CSA 2.33-M99 TEST METHODS AND RESULTING ITS/WHI PRODUCT CERTIFICATION. THE CODE AUTHORITY HAVING JURISDICTION MUST BE CONSULTED PRIOR TO PROCEEDING WITH THIS INSTALLATION METHOD.

WARNING:

FAILURE TO POSITION THE PARTS AND STOVE IN ACCORDANCE WITH THESE DIAGRAMS OR FAILURE TO USE ONLY PARTS SPECIFICALLY APPROVED WITH THIS APPLIANCE MAY RESULT IN PROPERTY DAMAGE OR PERSONAL INJURY. BE SURE TO MAINTAIN THE PROPER CLEARANCES TO COMBUSTIBLES AS DEFINED IN THIS MANUAL AND IN THE INSTRUCTIONS PROVIDED WITH EACH SIMPSON DURA-VENT COMPONENT.

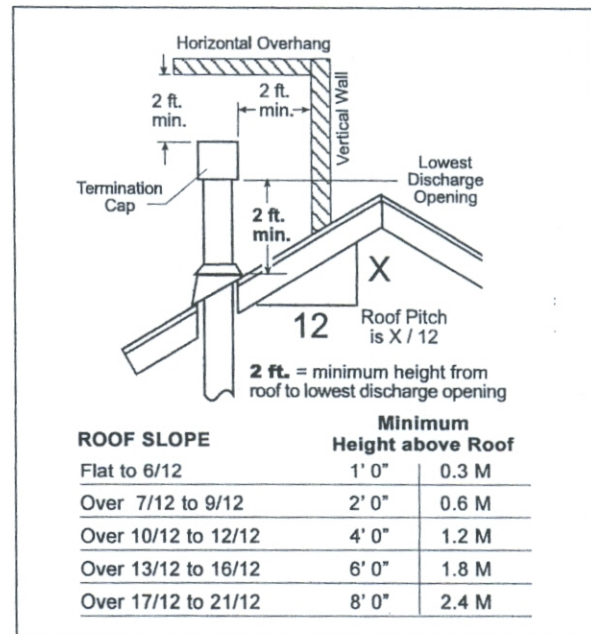

Figure 11. Gas Vent Height Rule: Vertical vent termination height above roof.

Horizontal Venting (Horizontal Termination)

- The maximum horizontal run made directly off the rear of the stove into a standard horizontal cap (#984 or #985) must be no more than a 9" section of Simpson Dura-vent (#907B). See Figure 12-1.
- The maximum horizontal run made directly off the rear of the stove into a 14" snorkel cap (#982) must be no more than a 24" section of Simpson Dura-vent (#904). See Figure 12-3.
- The horizontal termination cap must maintain a 3" clearance (80 mm) to any overhead combustible projections 2 1/2" (60 mm) or less. Maintain 12" (300 mm) clearance from projections exceeding 2 1/2". See Figure 13.
- Any horizontal run of vent must be level or have a 1/4" (5 mm) rise for every foot (300 mm) of run toward the termination cap. **DO NOT ALLOW THE VENT TO RUN DOWNWARD, AS THIS CAN CAUSE HIGH TEMPERATURES AND THE POSSIBILITY OF A FIRE.**
- A 1" (26 mm) clearance must be maintained around all co-axial vent pipe.
- For buildings with vinyl siding, a Vinyl Siding Standoff should be installed between the vent cap and the exterior wall (Simpson Dura-Vent #950). The Standoff prevents exposure of the vinyl siding to excessive heat that can damage the siding material.
- A 10" X 10" (250 mm x 250 mm) square hole is required to maintain proper vent clearances through a combustible wall. Simpson Dura-Vent Wall Thimble #942 installed according to the manufacturer's instructions meets clearance requirements.
- **DO NOT FILL AIR SPACE WITH ANY TYPE OF INSULATION.**
- Do not recess the termination cap into the exterior wall or siding.

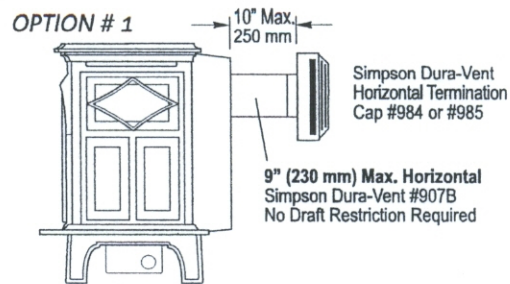

Figure 12-1. Maximum horizontal run to rear termination.

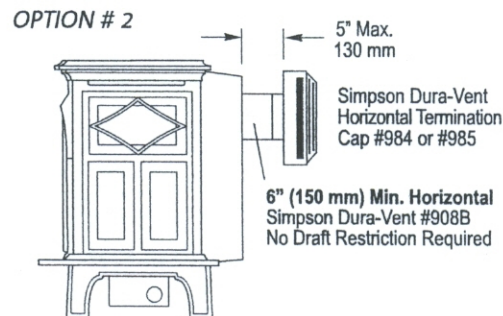

Figure 12-2. Minimum horizontal run to rear termination.

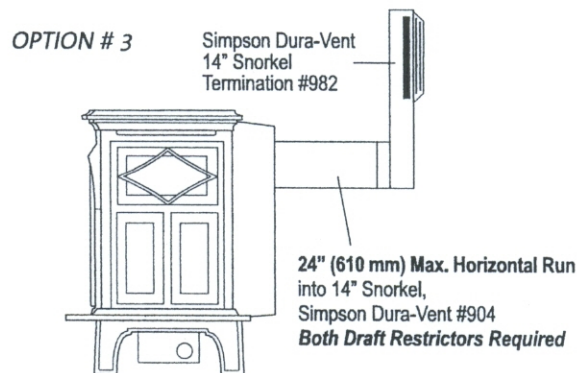

Figure 12-3. Maximum horizontal run to a snorkel termination.

IMPORTANT:
FOLLOW THE INSTALLATION INSTRUCTIONS PROVIDED WITH EACH SIMPSON DURA-VENT COMPONENT.

Vent Termination Requirements

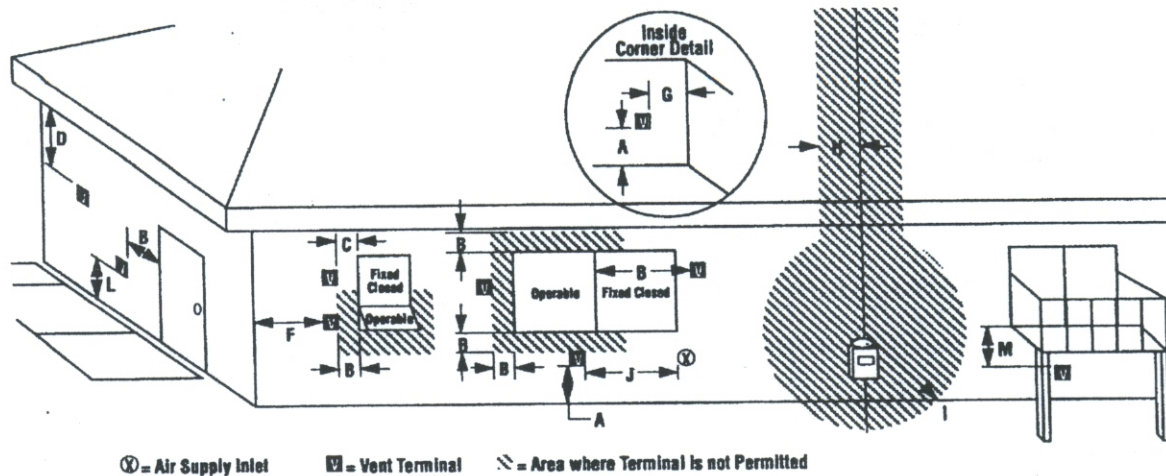

Figure 15. Vent Terminal Clearances - National Fuel Gas Code

A = Clearance above grade, veranda, porch, deck, or balcony: ***12 inches (30 cm) minimum.**

B = Clearance to window or door that may be opened: **9 inches (23 cm) minimum.** We recommend 12 inches to help prevent condensation.

C = Clearance to permanently closed window: **minimum 12 inches (30 cm)** recommended to prevent condensation on the window.

D = Vertical clearance to ventilated soffit located above the terminal within a horizontal distance of 2 feet (60 cm) from the centerline of the terminal: **18 inches (46 cm) minimum.**

E = Clearance to unventilated soffit: **12 inches (46 cm) minimum.**

F = Clearance to outside corner: **9 inches (23 cm) min.** Jøtul N.A. strongly recommends 12 inches (30 cm), particularly where windy conditions are prevalent.

G = Clearance to inside corner: **6 inches (16 cm) min.** Jøtul N.A. strongly recommends 12 inches (30 cm), particularly where windy conditions are prevalent.

H = *Not to be installed above a meter/regulator assembly **within 3 feet (90 cm)** horizontally from the center-line of the regulator.

I = Clearance to service regulator vent outlet: **6 feet (1.8 m) minimum.**

J = Clearance to nonmechanical air supply inlet to building or the combustion air inlet to any other appliance: ***12 inches (30 cm) minimum.**

K = Clearance to a mechanical air supply inlet: ***6 feet (1.8 m) minimum.**

L = ** Clearance above paved sidewalk or a paved driveway located on public property: ***7 feet (2.1 m) min.**

M = Clearance under veranda, porch, deck, or balcony: ***12 inches (30 cm) minimum.¹**

* As specified in CGA B149 Installation Codes. Note: Local Codes and Regulations may require different clearances.

** A vent shall not terminate directly above a sidewalk or driveway which is located between two single family dwellings and serves both dwellings.*

¹ Only permitted if veranda, porch, deck, or balcony, is fully open on a minimum of two sides beneath the floor.*