

DISPLAY THIS CARD ON PRINCIPAL FRONTAGE OF WORK



CITY OF PORTLAND BUILDING PERMIT

This is to certify that
R B ALLEN CO, INC.
PO BOX 770 - 131 LAFAYETTE RD
NORTH HAMPTON, ME 03862

For installation at
1364 CONGRESS ST
WESTGATE PLAZA

Job ID: 2012-03-3496-FAFS

CBL: 191- B-019-001

has permission to fit up fire alarm: CVS, Auto Zone & Laundry
provided that the person or persons, firm or corporation accepting this permit shall comply with all of the provisions of the Statues of Maine and of the Ordinances of the City of Portland regulating the construction, maintenance and use of the buildings and structures, and of the application on file in the department.

Notification of inspection and written permission procured before this building or part thereof is lathed or otherwise closed-in. 48 HOUR NOTICE IS REQUIRED.

A final inspection must be completed by owner before this building or part thereof is occupied. If a certificate of occupancy is required, it must be

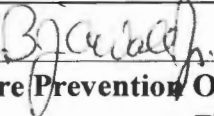
Fire Prevention Officer

(58)

Code Enforcement Officer / Plan Reviewer

THIS CARD MUST BE POSTED ON THE STREET SIDE OF THE PROPERTY
PENALTY FOR REMOVING THIS CARD



PORTLAND MAINE

Strengthening a Remarkable City, Building a Community for Life • www.portlandmaine.gov

Director of Planning and Urban Development
Penny St. Louis

Job ID: 2012-03-3496-FAFS
fit up fire alarm: CVS, Auto Zone &
Laundry

For installation at:
1364 CONGRESS ST
WESTGATE PLAZA

CBL: 191- B-019-001

Conditions of Approval:

Fire

The fire alarm system shall comply with the City of Portland Standard for Signaling Systems for the Protection of Life and Property. All fire alarm installation and servicing companies shall have a Certificate of Fitness from the Fire Department.

In field installation shall be installed per code as conditions dictate.

All smoke detectors and smoke alarms shall be photoelectric.

Records cabinet, FACP, annunciator(s), and pull stations shall be keyed alike.

Central Station monitoring for addressable fire alarm systems shall be by point.

All fire alarm records required by NFPA 72 should be stored in an approved cabinet located at the FACP labeled "FIRE ALARM RECORDS".

Installation of a Fire Alarm system requires a Knox Box to be installed per city ordinance.

The fire alarm system shall be certified by a master fire alarm company and have a new fire alarm inspection sticker.

System acceptance and commissioning must be coordinated with alarm and suppression system contractors and the Fire Department. Call 874-8703 to schedule.

Fire Alarm system shall be maintained. If system is to be off line over 4 hours a fire watch shall be in place. Dispatch notification required 874-8576.

Fire alarm system requires a wireless master box connection per city ordinance.

Sprinkler supervision shall be provided in accordance with NFPA 101, *Life Safety Code*, and NFPA 72, *National Fire Alarm and Signaling Code*.

City of Portland, Maine - Building or Use Permit Application

389 Congress Street, 04101 Tel: (207) 874-8703, FAX: (207) 8716

Job No: 2012-03-3496-FAFS	Date Applied: 3/13/2012	CBL: 191- B-019-001	
Location of Construction: 1364 CONGRESS ST	Owner Name: CHARTE WESTGATE LLC	Owner Address: 800 WESTCHESTER AVE SUITE S-632 RYE BROOK, NY 10573	Phone:
Business Name:	Contractor Name: JAMES A LAMSON, L&B CONTACTORS INC.	Contractor Address: P O BOX 51 LISBON MAINE 04250	Phone: 353-5521
Lessee/Buyer's Name:	Phone:	Permit Type: FIRE ALARM	Zone: B-2
Past Use: Retail, Personal Services and Offices Mixed Uses	Proposed Use: Same: Retail, personal Services and Office mixed uses - to install Fire Alarms in CVS, the laundry tenant and Auto Zone	Cost of Work: \$15,000.00	CEO District:
		Fire Dept: <input checked="" type="checkbox"/> Approved w/conditions <input type="checkbox"/> Denied <input type="checkbox"/> N/A	Inspection: Use Group: Type:
		Signature: <i>Bjorn Waldy</i> (58)	Signature:
Proposed Project Description: Fire Alarm		Pedestrian Activities District (P.A.D.)	
Permit Taken By: Gayle		Zoning Approval	

<p>1. This permit application does not preclude the Applicant(s) from meeting applicable State and Federal Rules.</p> <p>2. Building Permits do not include plumbing, septic or electrical work.</p> <p>3. Building permits are void if work is not started within six (6) months of the date of issuance. False informatin may invalidate a building permit and stop all work.</p>	<p>Special Zone or Reviews</p> <p><input type="checkbox"/> Shoreland</p> <p><input type="checkbox"/> Wetlands</p> <p><input type="checkbox"/> Flood Zone</p> <p><input type="checkbox"/> Subdivision</p> <p><input type="checkbox"/> Site Plan</p> <p>___ Maj ___ Min ___ MM</p> <p>Date: <i>01/3/14</i></p>	<p>Zoning Appeal</p> <p><input type="checkbox"/> Variance</p> <p><input type="checkbox"/> Miscellaneous</p> <p><input type="checkbox"/> Conditional Use</p> <p><input type="checkbox"/> Interpretation</p> <p><input type="checkbox"/> Approved</p> <p><input type="checkbox"/> Denied</p> <p>Date:</p>	<p>Historic Preservation</p> <p><input checked="" type="checkbox"/> Not in Dist or Landmark</p> <p><input type="checkbox"/> Does not Require Review</p> <p><input type="checkbox"/> Requires Review</p> <p><input type="checkbox"/> Approved</p> <p><input type="checkbox"/> Approved w/Conditions</p> <p><input type="checkbox"/> Denied</p> <p>Date: <i>[Signature]</i></p>
	CERTIFICATION		

I hereby certify that I am the owner of record of the named property, or that the proposed work is authorized by the owner of record and that I have been authorized by the owner to make this application as his authorized agent and I agree to conform to all applicable laws of this jurisdiction. In addition, if a permit for work described in the application is issued, I certify that the code official's authorized representative shall have the authority to enter all areas covered by such permit at any reasonable hour to enforce the provision of the code(s) applicable to such permit.

SIGNATURE OF APPLICANT	ADDRESS	DATE	PHONE
RESPONSIBLE PERSON IN CHARGE OF WORK, TITLE		DATE	PHONE

Contracted

2012 03 3496

66

Click Here to Return to Bill of Material/Index Fire Alarm Permit

B-2



If you or the property owner owes real estate or property taxes or user charges on any property within the city, payment arrangements must be made before permits of any kind are accepted.

Installation address: 1364 Congress Street CBL: 191 B 019

Exact location: (within structure) Rear Utility Corridor

Type of occupancy(s) (NFPA & ICC): Business Mercantile

Building owner: Charter Westgate LLC

System Designer (point of contact): Must be Tim Biron RB Allen Co. Master M1015

Designer phone: 207-657-2457 E-mail: timbiron@rballen.com

Installing contractor: L&B Electrical Contractors Inc. Certificate of Fitness No:

Contractor phone: 207-353-5521 E-mail: jlamson@lbelectric.net

This is a new application: YES NO New AES Master Box: YES NO (Include Master Box approval form)

Amendment to an existing permit: YES NO Permit no: 2011-10-2383-FAFS

The following documents shall be provided with this application:

- Checkboxes for Floor plans, Wiring diagram, Annunciator details, Input/ Output Matrix, Equipment data sheets, Electrical Permit Pulled, Scope of Work, 11 1/2 x 17s, pdf copy, Designer qualifications, Battery/ voltage drop calcs.

Master box approval only: YES NO (If yes check New AES Master Box above)

Stamp area containing COST OF WORK: \$14,871, PERMIT FEE: (\$10 PER \$1,000 + \$30 FOR THE FIRST \$1,000), RECEIVED MAR 13 2012, Dept. of Building Inspections City of Portland Maine

The designer shall be the responsible party for this application. Download a new copy of this application at www.portlandmaine.gov/fire for every submittal. Submit all plans in electronic PDF in addition to readable 11 1/2 x 17s to the Building Inspections Department, 389 Congress Street, Room 315, Portland, Maine 04101.

Prior to acceptance of any fire alarm system, a complete commissioning and acceptance test must be coordinated with all fire system contractors and the Fire Department, and proper documentation of such test(s) provided.

All installation(s) must comply with the City of Portland Technical Standard for Signaling Systems for the Protection of Life and Property, available at www.portlandmaine.gov/fire .

Applicant signature: [Signature] Date: 3-12-2012

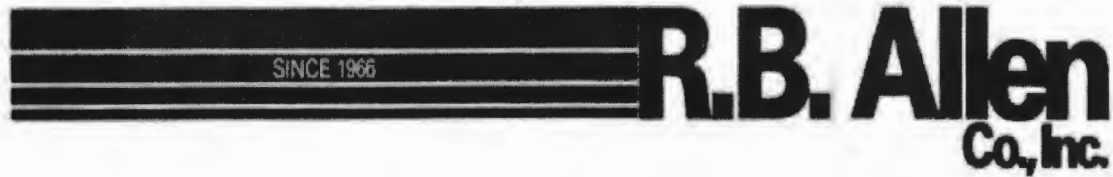

**Additions to Existing
EST Addressable System
Westgate Mall
Portland, Maine**

Prepared For:
L&B Electric
PO Box 51
28 Capital Ave
Lisbon, Maine 04250
Attn: Jim Lamson

Prepared By:
Tim Biron
R.B. Allen Co., Inc.
131 Lafayette Road
North Hampton, N.H. 03862

Reviewed By:
Tom DuBois
R.B. Allen Co., Inc.
131 Lafayette Road
North Hampton, N.H. 03862

[Click Here to View
Bill of Material/Index](#)



**Additions to Existing
EST Addressable Fire Alarm System
Westgate Mall
Portland , Maine**

Click on a Description to View Data Sheet

<u>Item</u>	<u>Qty</u>	<u>Catalog #</u>	<u>Description</u>	<u>Data Sheet</u>
1			Initiating Devices	
	7	SIGA-278	Addressable Double Action Manual Pull Station	85001-0279
2			Indicating Devices	
	13	GCF-HDVM	Horn/Strobe Unit, Ceiling Mount (Selectable candela)	85001-0573
	15	GCF-VM	Strobe Unit, Ceiling Mount (Selectable candela)	85001-0573
	1	BPS10A	Horn/Strobe Booster Power Supply	85005-0130
	2	12V6A5	Sealed Lead Acid Batteries - 7.2 Amp/Hour	85010-0127
3			Miscellaneous	

Click on a Description to View Document

Fire Alarm Installation Permit Application
System Scope of Work
System Sequence of Operation Matrix
Wesgate Mall Layout
Tenant Layouts
Horn/Strobe Booster Power Supply Standby Battery Calculations
Fire Alarm System Riser Diagram
System Service and Warranty

Click Here to Return to Bill of Material/Index

Westgate Plaza Fire Alarm Installation Scope of work. 2-24-12

This project consists of installing pull stations and notifications devices in the CVS Store, Laundry Tenant, Auto Zone auto parts store, as well as an added pull station by the door to the existing Fire Alarm Control Panel (FACP) that was installed last fall as the first phase of this project. We would be using the existing FACP and Power Booster Panels that were also installed as part of the first phase with this work in mind. No work in any unoccupied spaces is included in this phase. L & B Electrical Contractors would install all of the field wiring and RB Allen technicians would do the final connections at the panel and test and certify the system.

The following work was completed last fall and is listed here for reference only.

As part of phase 1 on this project the following work has been completed. There is a new addressable FACP installed in the rear service corridor on the first floor. There is a sign on the rear exterior of the door to this space stating "Fire Alarm Control Panel and Master Box Inside". This FACP will be used to serve the mall area except for Shaws. There is a new AES radio box installed in this space as well as two Power Booster Panels to serve annunciation devices throughout the mall. There is a document storage box inside this space and a KNOX box by the exterior door to this space.

On the front of the building on the right side of the Mercy space there is a 16 Zone annunciator installed on the exterior of the building. There is an exterior strobe mounted to the underside of the canopy at the front edge.

We installed new devices for the Anytime Fitness spaces per the riser and the print. We also be installed a new smoke detector at the FACP location. The sprinkler flow and tamper switches at the rear of CVS are tied onto this new FACP. We installed new conductors to the existing panel at Mercy and tied the annunciation as well as the indication circuits into the new FACP. The sprinkler riser in the rear basement below Advance Auto Parts was tied into this new panel.

SEQUENCE OF OPERATION MATRIX

Click Here to Return to
Bill of Material/Index

System Inputs	A	C	E	G	H	I	J	K	L	M	N	O	P	Q	R	S	
	Activate Common Alarm Indicator at FACP and Annunciator w/ Device Location	Transmit Alarm to Central Station via Radiobox and UDACT	Activate Building Audible Evacuation Signals	Activate All Visual Circuits	Activate Building Exterior Strobe	Activate Elevator Shaft Demper(if needed)	Recall Elevator to Appropriate Floor level	Activate Common Supervisory Indicator at FACP and Annunciator w/ Device Location	Transmit Supervisory Signal to Central Receiving Station	Shut Down Associated HVAC Unit	Activate Common Trouble Indicator at FACP and Annunciator w/ Device Location	Transmit Trouble Signal to Central Receiving Station	Close Magnetically Held Fire Doors				
1 Manual Fire Stations	X	X	X	X	X	X											
2 System Smoke or Heat Detector	X	X	X	X	X	X						X	X				
3 Elevator Smoke or Heat Detector							X						X	X			
4 Heat Detector Duct Smoke Detector									X				X	X			
5 System Waterflow	X	X	X	X	X	X							X	X			
6 System Tamper Switch							X	X									
7 Fire Alarm - AC Failure										X	X						
8 Fire Alarm - Low Battery										X	X						
9 System Open Circuit										X	X						
10 System Ground Fault										X	X						
11 NAC Short Circuit							X	X									
12 NAC Open Circuit										X	X						
13																	
14																	
15																	
16																	

Click Here to Return to
Bill of Material/Index

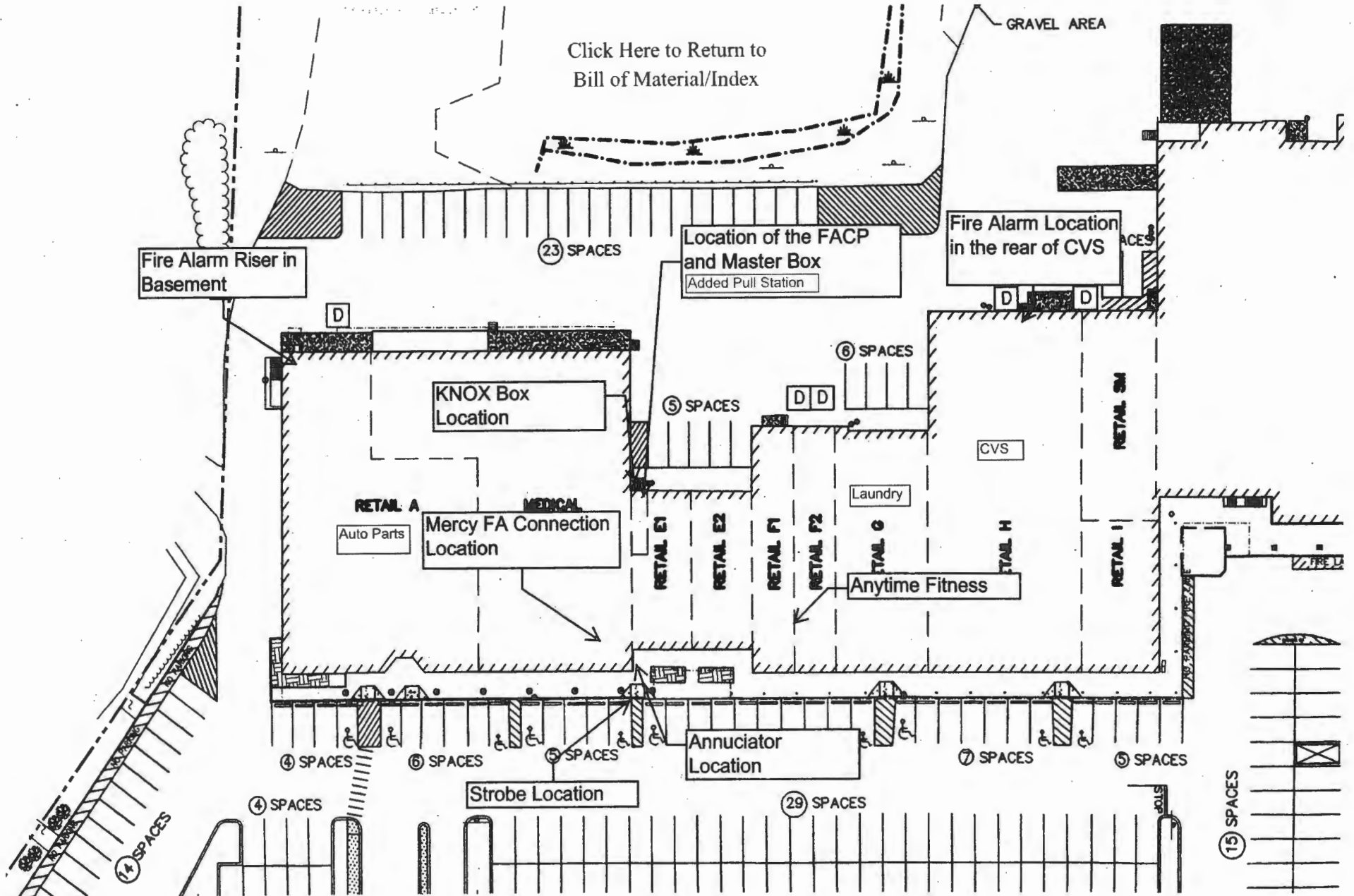

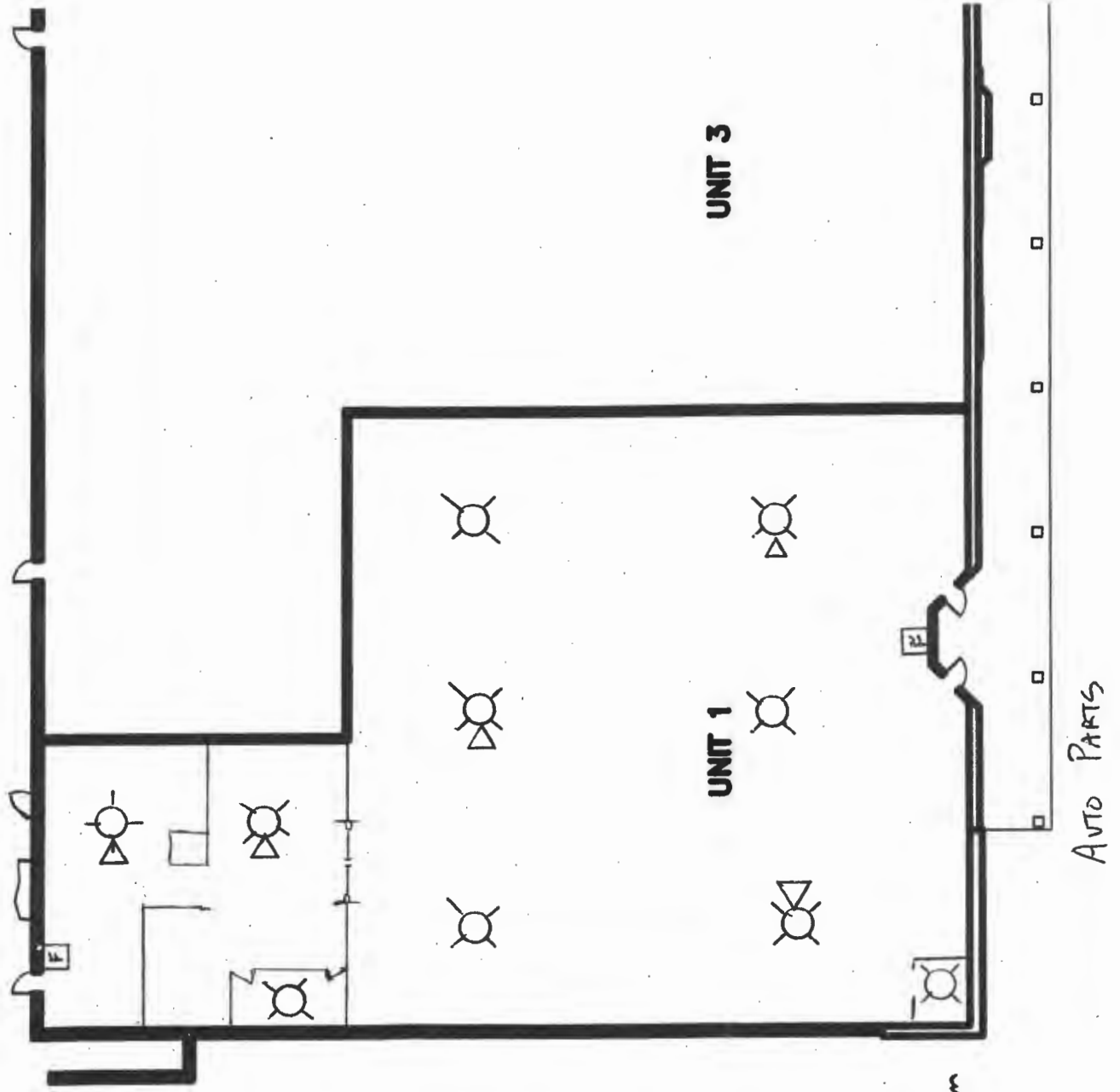

□ Pull Station

⊗ Ceiling Mt. Strobe

⊗ Ceiling Mt. Horn/strobe

Click Here to return to
Bill of Material/Index



**Fire Alarm System Additions
Wesgate Mall - Portland, Maine
Booster Power Supply Standby Battery Calculations**

[Click Here to Return to
Bill of Material/Index](#)

Strobe Booster Panel

	G1RF-HDVM			G1RF-VM			GCF-HDVM	GCF-VM	Quiescent Current	Alarm Current	Remaining % of Ckt Capacity
	30cd	75cd	110cd	15cd	30cd	75cd	75cd	75cd			
	109	193	248	71	98	188	214	205			
Panel									0.0700		
Circuit 1							5	5		2.0950	16.20 %
Circuit 2							4	4		1.6760	32.96 %
Circuit 3							4	6		2.0860	16.56 %
Circuit 4										0.0000	100.00 %
									0.0700	5.8570	
									Total Quiescent	Total Alarm	41.43 % Remaining % Panel

Total Quiescent Amp x Time Required (24 Hours) 1.680 AmpHr
 Total Alarm Amp x Time Required (15 Minutes) 1.464 AmpHr
 Total Battery Required 3.144 AmpHr
 Total Battery Required + 20% **3.773 AmpHr**
 Battery Supplied **7.2 AmpHr**

All currents are expressed as mA.
 Max current per ckt = 2.5 Amps. Max current per panel = 10.0 Amps.

**Fire Alarm System Additions
Westgate Mall - Portland, Maine
NAC Circuit Voltage Drop/Maximum Length Calculations**

[Click Here to Return to
Bill of Material/Index](#)

Formulas Used:

$$R_t = (D) \times (R_w) / 1000'$$

$$V_d = (R_t) \times (I_t)$$

Substitute for (R_t) and solve for D

$$D = ((4.0) \times (1000)) / ((R_w) \times (I_t))$$

R_t = Total Circuit Resistance
D = Total Circuit Length (Feet)
R_w = Wire Resistance (Ω) per 1000' Pair (Ohms)
V_D = Circuit Voltage Drop (Max allowed is 4.0Vdc)
I_t = Total Circuit Current

Notes:

- 1 NAC Circuit terminal voltage 24Vdc.
- 2 A maximum allowable voltage drop of 4Vdc will provide a minimum of 20 Vdc per circuit.
- 3 Current values listed per device are based on 20Vdc.

HORN/STROBE CIRCUIT MAX WIRE LENGTH CALCULATION

Current (mA)	G1RF-HDVM			G1RF-VM			GCF-HDVM	GCF-VM	Total Circuit Current	Ω per 1000' Pair		Volt Drop
	109	193	248	71	98	188	214	205		12AWG (3.5)	14AWG (5.2)	
Ckt/Cd	30cd	75cd	110cd	15cd	30cd	75cd	75cd	75cd	Amp	Max Length (Ft)	Max Length (Ft)	
Circuit 1							5	5	2.0950	545.52	367.17	4.0
Circuit 2							4	4	2.3800	480.19	323.21	4.0
Circuit 3							4	6	2.9860	382.74	257.61	4.0
Circuit 4									0.0000			4.0

Click Here to Return to
Bill of Material/index

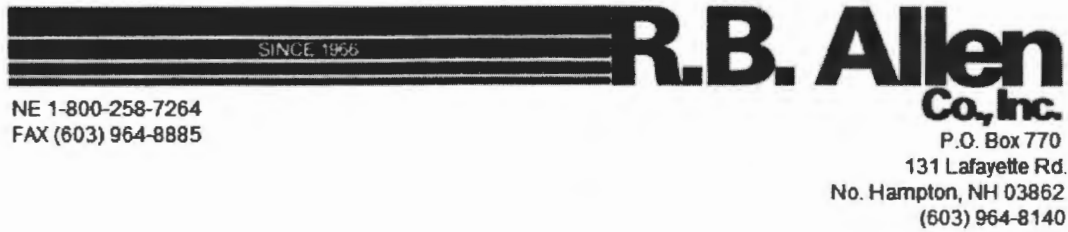

Service and Warranty

R.B. Allen Co., Inc. is a UL Certified ISO 9001 registered Fire Alarm Distributor since 1966 with offices located in North Hampton, NH and Woonsocket, RI. The service policies of R.B. Allen Company are no charge to the customer for warranty work including parts and labor for two (2) years from the time of final acceptance.

R.B. Allen Company warranty applies only to the equipment it provides and does not cover defective wiring or equipment provided by the Electrical Contractor.

Service calls resulting from acts of nature, acts of vandalism, or acts which are beyond the control of the equipment manufacturer are excluded under the guarantee and shall be considered a billable call.

R.B. Allen Company factory trained and certified technician will provide job site supervision during installation of the system and perform final connections, testing and adjusting of the Fire Alarm System. They also will instruct the owner's personnel on the operation and maintenance of the fire alarm system.

Manual Pull Stations

SIGA-270, SIGA-270P,
SIGA-278



Overview

The SIGA-270 and SIGA-278 series Manual Pull Stations are part of EST's Signature Series system. The SIGA-270 Fire Alarm Manual Pull Stations feature our very familiar teardrop shape. They are made from die-cast zinc and finished with red epoxy powder-coat paint complemented by aluminum colored stripes and markings. With positive pull-lever operation, one pull on the station handle breaks the glass rod and turns in a positive alarm, ensuring protection plus fool-proof operation. Presignal models (SIGA-270P) are equipped with a general alarm (GA) keyswitch for applications where two stage operation is required. The up-front highly visible glass rod discourages tampering, but is not required for proper operation.

EST's double action single stage SIGA-278 station is a contemporary style manual station made from durable red colored lexan. To initiate an alarm, first lift the upper door marked "LIFT THEN PULL HANDLE", then pull the alarm handle.

Standard Features

Note: Some features described here may not be supported by all control systems. Check your control panel's Installation and Operation Guide for details.

- **Traditional familiar appearance**
SIGA-270 models feature our familiar teardrop design with simple positive pull action and sturdy die-cast metal body.
- **One stage (GA), two stage (pre-signal), and double action models**
SIGA-270 models are available for one or two stage alarm systems. The single stage double action SIGA-278 features a rugged Lexan housing with keyed reset mechanism.

- **Break glass operation**
An up-front visible glass rod on the SIGA-270 discourages tampering.
- **Intelligent device with integral microprocessor**
All decisions are made at the station allowing lower communication speed while substantially improving control panel response time. Less sensitive to line noise and loop wiring properties; twisted or shielded wire is not required.
- **ADA Compliant**
Meets ADA requirements for manual pull stations.
- **Electronic Addressing with Non-volatile memory**
Permanently stores programmable address, serial number, type of device, and job number. Automatically updates historic information including hours of operation, last maintenance date, number of alarms and troubles, and time and date of last alarm.
- **Automatic device mapping**
Each station transmits wiring information to the loop controller regarding its location with respect to other devices on the circuit.
- **Stand-alone operation**
The station inputs an alarm even if the loop controller's polling interrogation stops.
- **Diagnostic LEDs**
Status LEDs; flashing GREEN shows normal polling; flashing RED shows alarm state.
- **Designed for high ambient temperature operation**
Install in ambient temperatures up to 120 °F (49 °C).

Application

The operating characteristics of the fire alarm stations are determined by their sub-type code or "Personality Code". NORMALLY-OPEN ALARM - LATCHING (Personality Code 1) is assigned by the factory; no user configuration is required. The device is configured for Class B IDC operation. An ALARM signal is sent to the loop controller when the station's pull lever is operated. The alarm condition is latched at the station.

Compatibility

Signature Series manual stations are compatible only with EST's Signature Loop Controller.

Warnings & Cautions

This device will not operate without electrical power. As fires frequently cause power interruption, we suggest you discuss further safeguards with your local fire protection specialist.

Testing & Maintenance

To test (or reset) the station simply open the station and operate the exposed switch. The SIGA-270 series are opened with a tool; the SIGA-278 requires the key which is supplied with that station.

The station's automatic self-diagnosis identifies when it is defective and causes a trouble message. The user-friendly maintenance program shows the current state of each Signature series device and other pertinent messages. Single devices may be deactivated temporarily, from the control panel. Availability of maintenance features is dependent on the fire alarm system used.

Scheduled maintenance (Regular or Selected) for proper system operation should be planned to meet the requirements of the Authority Having Jurisdiction (AHJ). Refer to current NFPA 72 and ULC CAN/ULC 536 standards.

Typical Wiring

The fire alarm station's terminal block accepts #18 AWG (0.75mm²) to #12 AWG (2.5mm²) wire sizes. See Signature Loop Controller catalog sheet for detailed wiring requirement specifications.

Wiring Notes

1. Refer to Signature Loop Controller manual for maximum wire distance.
2. All wiring is power limited and supervised.

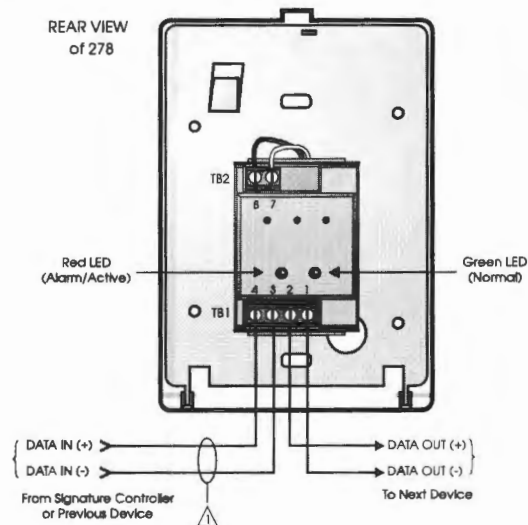

Figure 4. Single Stage Systems

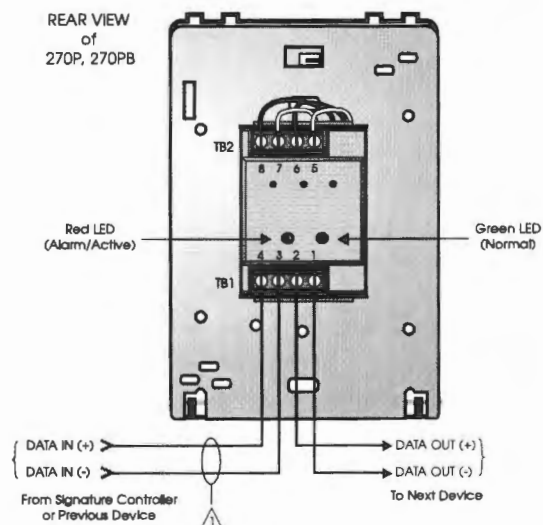

Figure 5. Two Stage Systems

Installation

Single-stage Signature Series fire alarm manual pull stations mount to North American 2½ inch (64 mm) deep 1-gang boxes.

Two stage presignal (270P) models require 1½ inch (38 mm) deep 4-inch square boxes with 1-gang, ½-inch raised covers. Openings must be angular. *Rounded openings are not acceptable.* Recommended box: Steel City Model 52-C-13; in Canada, use Iberville Model CI-52-C-49-1/2.

All models include terminals are suited for #12 to #18 AWG (2.5 mm² to 0.75 mm²) wire size. Edwards recommends that these fire alarm stations be installed according to latest recognized edition of national and local fire alarm codes.

Electronic Addressing: The loop controller electronically addresses each manual station, saving valuable time during system commissioning. Setting complicated switches or dials is not required. Each station has its own unique serial number stored in its on-board memory. The loop controller identifies each device on the loop and assigns a “soft” address to each serial number. If desired, the stations can be addressed using the SIGA-PRO Signature Program/Service Tool.

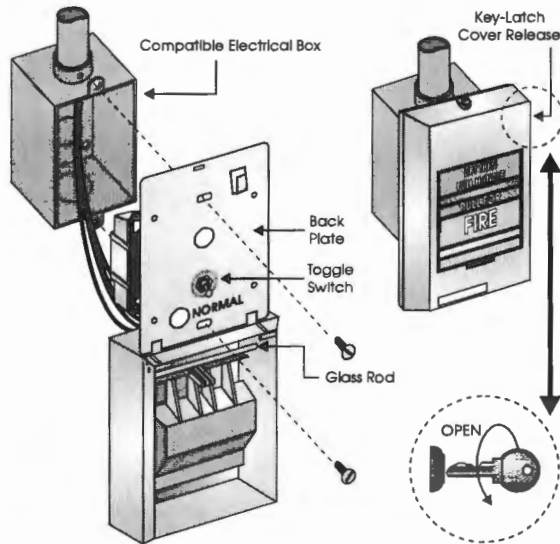

Figure 1. SIGA-278 installation

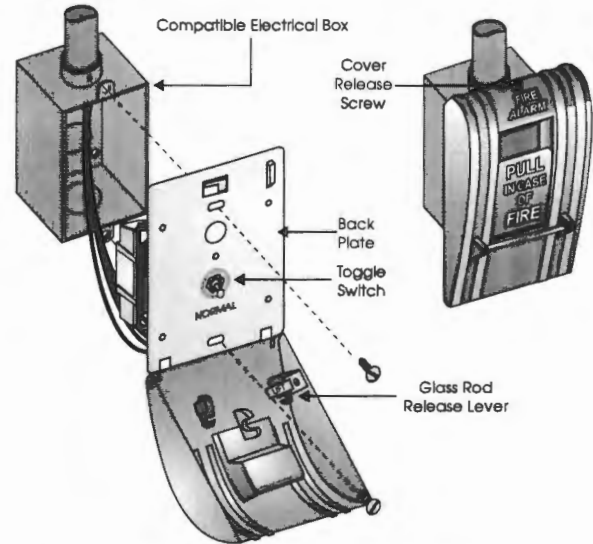

Figure 2. SIGA-270, SIGC-270F, SIGC-270B installation

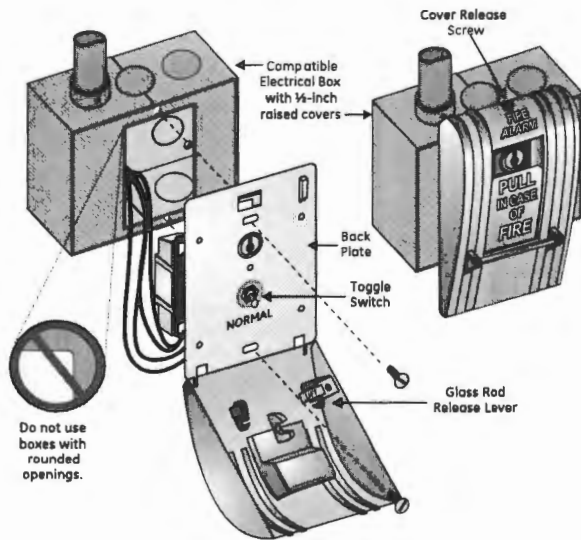

Figure 3. SIGA-270P, SIGC-270PB installation



Detection & alarm since 1872

U.S.
T 888-378-2329
F 866-503-3996

Canada
Chubb-Edwards
T 519 376 2430
F 519 376 7258

Southeast Asia
T : +65 6391 9300
F : +65 6391 9306

India
T : +91 80 4344 2000
F : +91 80 4344 2050

Australia
T +61 3 9239 1200
F +61 3 9239 1299

Europe
T +32 2 725 11 20
F +32 2 721 86 13

Latin America
T 305 593 4301
F 305 593 4300

utcfireandsecurity.com

© 2010 UTC Fire & Security.
All rights reserved.

Specifications

Catalog Number	SIGA-270, SIGC-270F, SIGC-270B	SIGA-270P, SIGC-270PB	SIGA-278
Description	Single Action - One Stage	Single Action - Two Stage (Presignal)	Double Action - One Stage
Addressing Requirements	Uses 1 Module Address	Uses 2 Module Addresses	Uses 1 Module Address
Operating Current	Standby = 250µA Activated = 400µA	Standby = 396µA Activated = 680µA	Standby = 250µA Activated = 400µA
Construction & Finish	Diecast Zinc - Red Epoxy with aluminum markings		Lexan - Red with white markings
Type Code	Factory Set		
Operating Voltage	15.2 to 19.95 Vdc (19 Vdc nominal)		
Storage and Operating Environment	Operating Temperature: 32°F to 120°F (0°C to 49°C) Storage Temperature: -4°F to 140°F (-20°C to 60°C) Humidity: 0 to 93% RH		
LED Operation	On-board Green LED - Flashes when polled On-board Red LED - Flashes when in alarm Both LEDs - Glow steady when in alarm (stand-alone)		
Compatibility	Use With: Signature Loop Controller		
Agency Listings	UL, ULC (note 1), MEA, CSFM		

Note: SIGC-270F, SIGC-270B and SIGC-270PB are ULC listed only. Suffix "F" indicates French markings. Suffix "B" indicates English/French bilingual markings.

Ordering Information

Catalog Number	Description	Ship Wt. lbs (kg)
SIGA-270	One Stage Fire Alarm Station, English Markings - UL/ULC Listed	
SIGC-270F	One Stage Fire Alarm Station, French Markings - ULC Listed	
SIGC-270B	One Stage Fire Alarm Station, French/English Markings - ULC Listed	
SIGA-270P	Two Stage (Presignal) Fire Alarm Station, English Markings - UL/ULC Listed	1 (0.5)
SIGC-270PB	Two Stage (Presignal) Fire Alarm Station, French/English Markings - ULC Listed	

Accessories		
32997	GA Key w/Tag - for pre-signal station (CANADA ONLY)	
276-K2	GA Key - for pre-signal station (USA ONLY)	
276-K1	Station Reset Key, Supplied with all Key Reset Stations	
27165	12 Glass Rods - for SIGA-270 series (CANADA ONLY)	0.1 (.05)
270-GLR	20 Glass Rods - for SIGA-270 series (USA ONLY)	
276-GLR	20 Glass Rods - for SIGA-278 series	
276B-RSB	Surface Mount Box, Red - for SIGA pull stations	1 (0.6)

Field Configurable Ceiling Horn -Strobes

Genesis Series



Overview

Genesis ceiling horn-strobes are small, compact, and attractive audible-visible emergency signaling devices. Protruding no more than 1.6" (41 mm) from the ceiling, Genesis horn-strobes blend with any decor.

Thanks to patented breakthrough technology, Edwards Genesis strobes do not require bulky specular reflectors and lenses. Instead, an exclusive cavity design conditions light to produce a highly controlled distribution pattern. Significant development efforts employing this new technology have given rise to a new benchmark in strobe performance – FullLight technology.

FullLight strobe technology produces a smooth light distribution pattern without the spikes and voids characteristic of specular reflectors. This ensures the entire coverage area receives consistent illumination from the strobe flash. As a result, Genesis strobes with FullLight technology go well beyond the minimum UL-required "cross" pattern.

Depending on the model, Genesis horn-strobes feature 15 to 95, or 95 to 177 candela output (see ordering information), which is selectable with a conveniently-located switch on the front of the device. The candela output setting is clearly visible even after final installation, yet it remains locked in place to prevent unauthorized movement after installation.

Genesis horn-strobes feature textured housings in architecturally neutral white or eye-catching fire alarm red. An ingenious iconographic symbol indicates the purpose of the device. This universal symbol is code-compliant and is easily recognized by all building occupants regardless of what language they speak. Models with "FIRE" markings are also available.

Standard Features

- **Field configurable – no need to remove the device!**
 - 15/30/75/95 cd and 95/115/150/177 cd models available
 - Switch settings remain visible even after the unit is installed
 - Low/high dB settings
- **Unique low-profile design**
 - 30 per cent slimmer profile than comparable signals
 - No visible mounting screws
 - Available with white or red housings
- **Easy to install**
 - Fits all standard 4" square electrical boxes with plenty of room behind the signal for extra wire – no extension ring or trim plate needed
 - Pre-assembled with captive hardware – no loose pieces
 - #18 to #12 AWG terminals – ideal for long runs or existing wiring
- **Unparalleled performance**
 - Exclusive FullLight strobe technology produces the industry's most even light distribution
 - Single high-efficiency microprocessor controls both horn and strobe
 - Low current draw minimizes system overhead
 - Independent horn control provided over a single pair of wires
 - Highly regulated in-rush current allows the maximum number of strobes on a circuit
 - 100 dB peak – multiple frequency tone improves wall penetration

Application

Genesis strobes are UL 1971-listed for use indoors as ceiling-mounted public-mode notification appliances for the hearing impaired. Prevailing codes require strobes to be used where ambient noise conditions exceed 105 dBA (87dBA in Canada), where occupants use hearing protection, and in areas of public accommodation as defined in the *Americans with Disabilities Act* (see *application notes – USA*).

Combination horn-strobe signals must be installed in accordance with guidelines established for strobe devices.

Strobes

Genesis strobes are UL 1971-listed for use indoors as wall-mounted public-mode notification appliances for the hearing impaired. Prevailing codes require strobes to be used where ambient noise conditions exceed specified levels, where occupants use hearing protection, and in areas of public accommodation. Consult with your Authority Having Jurisdiction for details.

All Genesis strobes exceed UL synchronization requirements (within 10 milliseconds other over a two-hour period) when used with a synchronization source. Synchronization is important in order to avoid epileptic sensitivity.

NOTE: The flash intensity of some visible signals may not be adequate to alert or waken occupants in the protected area. Research indicates that the intensity of strobe needed to awaken 90% of sleeping persons is approximately 100 cd. Edwards recommends that strobes in sleeping rooms be rated at at least 110 cd.

WARNING: These devices will not operate without electrical power. As fires frequently cause power interruptions, further safeguards such as backup power supplies may be required.

Horns

Genesis horn output reaches as high as 99 dB (peak) and features a unique multiple frequency tone that results in excellent wall penetration and an unmistakable warning of danger. All models may be configured for either coded or non-coded signal circuits. They can also be set for low dB output with a jumper cut that reduces horn output by about 5 dB.

The suggested sound pressure level for each signaling zone used with alert or alarm signals is at least 15 dB above the average ambient sound level, or 5 dB above the maximum sound level having a duration of at least 60 seconds, whichever is greater, measured 5 feet (1.5 m) above the floor. The average ambient sound level is, A-weighted sound pressure measured over a 24-hour period.

Doubling the distance from the signal to the ear will theoretically result in a 6 dB reduction of the received sound pressure level. The actual effect depends on the acoustic properties of materials in the space. A 3 dBA difference represents a barely noticeable change in volume.

Dimensions

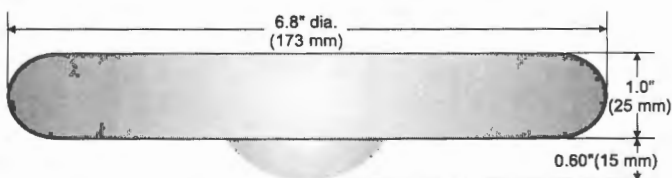

Installation and Mounting

All models are intended for indoor wall or ceiling applications only. Horn-strobes mount to any flush North-American 4" square electrical box.

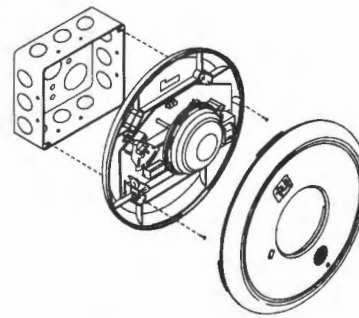

Genesis ceiling horn-strobes simply unlatch and twist to open. This gains access to mounting screws and the selectable candela switch. The shallow depth of Genesis devices leaves ample room behind the signal for extra wiring. Once installed with the cover in place, no mounting screws are visible.

Edwards recommends that these fire alarm horn-strobes always be installed in accordance with the latest recognized edition of national and local fire alarm codes.

Field Configuration

Depending on the model, Genesis horn-strobes may be set for 15 to 95, or 95 to 177 candela output (see ordering information). The output setting is changed by simply opening the device and sliding the switch to the desired setting. The horn-strobe does not have to be removed to change the output setting. The setting remains visible through a small window on the front of the device after the cover is closed.

The horn-strobe comes factory set for high dB output. Low dB output may be selected by cutting a jumper on the circuit board. This reduces the output by about 5 dB.

Wiring

Field wiring terminals accommodate #18 to #12 AWG (0.75 mm² to 2.5 mm²) wiring. Horn/strobes are interconnected with a single pair of wires as shown below.

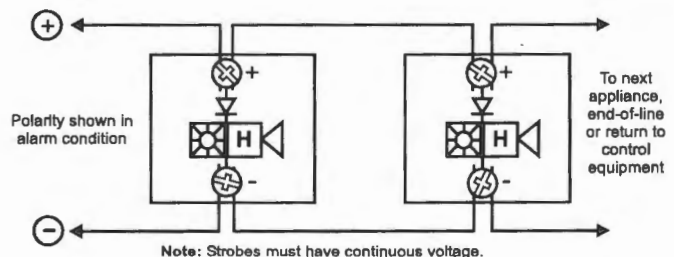

Current Draw

GC-HDVM Temporal Horn-strobe: High dB Setting

UL Rating	15 cd RMS	30 cd RMS	75 cd RMS	95 cd RMS
16 Vdc	147	190	316	372
16 Vfwr	189	253	417	451

GC-HDVM Temporal Horn-strobe: High dB Setting

Typical Current	15 cd		30 cd		75 cd		95 cd	
	RMS	Mean	RMS	Mean	RMS	Mean	RMS	Mean
16 Vdc	111	95	152	143	281	276	333	328
20 Vdc	91	80	124	117	219	214	257	251
24 Vdc	80	71	108	101	185	180	212	207
33 Vdc	69	62	89	84	144	140	160	156
16 Vfwr	153	81	218	123	388	240	420	268
20 Vfwr	141	70	190	100	325	188	378	219
24 Vfwr	135	64	176	90	280	154	310	180
33 Vfwr	139	61	167	80	241	122	254	133

GC-HDVM Temporal Horn-strobe: Low dB Setting

Typical Current	15 cd		30 cd		75 cd		95 cd	
	RMS	Mean	RMS	Mean	RMS	Mean	RMS	Mean
16 Vdc	108	91	149	139	275	269	327	322
20 Vdc	87	75	120	113	209	209	250	245
24 Vdc	76	66	103	97	180	175	205	201
33 Vdc	64	57	85	80	138	135	153	150
16 Vfwr	141	76	204	118	384	239	418	265
20 Vfwr	127	65	176	95	312	181	371	214
24 Vfwr	118	60	162	82	262	149	301	171
33 Vfwr	127	56	155	73	229	118	249	129

Notes and Comments

1. Current values are shown in mA.
2. UL Nameplate Rating can vary from Typical Current due to measurement methods and instruments used.
3. Edwards recommends using the Typical Current for system design including NAC and Power Supply loading and voltage drop calculations.
4. Use the Vdc RMS current ratings for filtered power supply and battery AH calculations. Use the Vfwr RMS current ratings for unfiltered power supply calculations.
5. Fuses, circuit breakers and other overcurrent protection devices are typically rated for current in RMS values. Most of these devices operate based upon the heating affect of the current flowing through the device. The RMS current (not the mean current) determines the heating affect and therefore, the trip and hold threshold for those devices.
6. Our industry has used 'mean' currents over the years. However, UL will direct the industry to use the 2004 RMS values in the future.

GC-HDVMH High cd Temporal Horn-strobe: High dB Setting

95 cd RMS	115 cd RMS	150 cd RMS	177 cd RMS
341	399	506	570
487	578	670	711

GC-HDVMH High cd Temporal Horn-strobe: High dB Setting

95 cd		115 cd		150 cd		177 cd	
RMS	Mean	RMS	Mean	RMS	Mean	RMS	Mean
324	322	377	374	477	474	554	551
258	256	299	296	369	366	417	414
220	217	252	249	304	301	341	338
172	169	188	185	223	220	244	241
463	265	535	312	665	400	718	442
392	211	439	240	517	287	587	334
346	179	382	212	458	246	498	271
296	142	323	152	358	178	387	194

GC-HDVMH High cd Temporal Horn-strobe: Low dB Setting

95 cd		115 cd		150 cd		177 cd	
RMS	Mean	RMS	Mean	RMS	Mean	RMS	Mean
317	315	378	376	480	477	544	542
252	250	292	290	364	362	414	411
212	211	245	243	297	295	334	332
159	157	181	179	215	213	234	232
461	265	521	305	656	396	705	432
381	208	437	242	508	285	576	326
335	172	370	195	440	235	485	264
285	134	308	149	349	169	373	186

dBA output

High dB Setting	UL464		Average	Peak
	Temporal	Steady	Temporal/ Steady	Temporal/ Steady
16 Vdc	79.8	83.2	90.6	93.6
24 Vdc	83.3	85.4	93.6	96.6
33 Vdc	85	87.8	95.7	98.7

Low dB Setting	UL464		Average	Peak
	Temporal	Steady	Temporal/ Steady	Temporal/ Steady
16 Vdc	75	79.3	86.3	88.7
24 Vdc	78	83	88.8	92.4
33 Vdc	80.9	85.9	91.8	95.1

Notes

1. All values shown are dBA measured at 10 feet (3.01m);
2. UL464 values measured in reverberation room;
3. Average and Peak values are measured in anechoic chamber.

Light output - (effective cd)

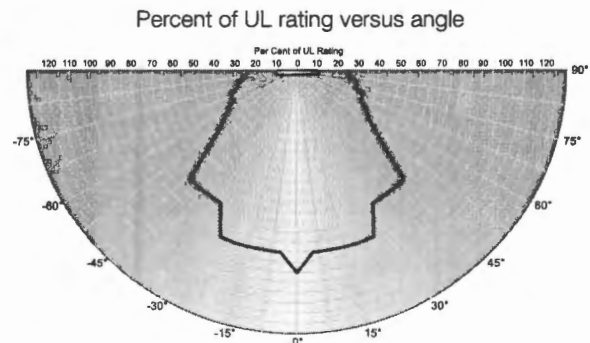



Detection & alarm since 1872

U.S.
T 888-378-2329
F 866-503-3996

Canada
Chubb Edwards
T 519 376 2430
F 519 376 7258

Southeast Asia
T : +65 6391 9300
F : +65 6391 9306

India
T : +91 80 4344 2000
F : +91 80 4344 2050

Australia
T +61 3 9239 1200
F +61 3 9239 1299

Europe
T +32 2 725 11 20
F +32 2 721 86 13

Latin America
T 305 593 4301
F 305 593 4300

utcfireandsecurity.com

© 2010 UTC Fire & Security.
All rights reserved.

Specifications

Housing	Textured UV stabilized, color impregnated engineered plastic. Exceeds 94V-0 UL flammability rating. Red and white models available.
Lens	Optical grade polycarbonate (clear)
Mounting	North-American 4" square box, 2 1/8" (54 mm) deep (indoor wall or ceiling applications only).
Wire connections	Screw terminals: single input for both horn and strobe. #18 to #12 AWG (0.75 mm ² to 2.5 mm ²) wire size
Operating environment	Indoor: 32-120°F (0-49°C) ambient temperature. 93% relative humidity
Agency listings/approvals	Meets or exceeds ULC-S541, year 2004 UL requirements for standards UL1638 and UL1971, and complies with UL1480. All horn-strobes comply with ADA Code of Federal Regulation Chapter 28 Part 36 Final Rule. CSFM, MEA. FM pending.
Operating voltage	GC-HDVM series temporal-tone horn-strobes: non-coded, filtered 16-33 Vdc or unfiltered 16-33 Vdc FWR (or coded (audible NAC only) when used with optional G1M Genesis Signal Master)
Strobe output rating	UL 1971, UL 1638, ULC S526: selectable 15/30/75/95 cd (GC-HDVM) and 95/115/150/177 cd (GC-HDVMH)
Strobe flash rate	GC-HDVM series temporal-tone horn-strobes: one flash per second synchronized with optional G1M Genesis Signal Master indefinitely within 10 milliseconds (or self-synchronized within 200 milliseconds over thirty minutes on a common circuit without G1M Genesis Signal Master) Temporal setting (private mode only): synchronized to temporal output of horns on same circuit
Synchronization Sources	G1M-RM, SIGA-CC1S, SIGA-MCC1S, BPS6A, BPS10A
Horn pulse rate	GC-HDVM series temporal-tone horn-strobes: temporal rate synchronized with optional G1M Genesis Signal Master indefinitely within 10 milliseconds (or self-synchronized within 200 milliseconds over thirty minutes on a common circuit without G1M Genesis Signal Master)
Temporal audible pattern	½ sec ON, ½ sec OFF, ½ sec ON, ½ sec OFF, ½ sec ON, 1½ sec OFF, then repeat cycle

Ordering Information

Catalog Number	Housing Color	Marking	Description	Ship Wt. lbs (kg)
GC-HDVM	White	None	Genesis Ceiling/Wall Horn-Strobe with selectable 15, 30, 75, or 95 cd output	0.82 (1.8)
GCF-HDVM	White	"FIRE"		
GC-HDVMH	White	None	Genesis Ceiling/Wall Horn-Strobe with selectable 95, 115, 150, or 177 cd output	
GCF-HDVMH	White	"FIRE"		

Accessories

G1M-RM	Genesis Signal Master – Remote Mount (1-gang)	0.2 (0.1)
SIGA-CC1S	Intelligent Synchronization Output Module (2-gang)	0.5 (0.23)
SIGA-MCC1S	Intelligent Synchronization Output Module (Plug-in UIO)	0.18 (0.08)



White Field Configurable Ceiling Horn-Strobes may be ordered with or without optional 'FIRE' marking. Red Horn-Strobes come with 'FIRE' marking.



Click Here to Return to
Bill of Material/Index

EST Catalog ▶ Strobes, Horns, Bells, Chimes

Field Configurable Ceiling Strobes

Genesis Series



Overview

Genesis life safety and mass notification/emergency communications (ECS/MNS) ceiling strobes are small, compact, and attractive visible emergency signaling devices. Protruding no more than 1.6" (41 mm) from the ceiling, Genesis strobes blend with any decor.

Thanks to patented breakthrough technology, Edwards Genesis strobes do not require bulky specular reflectors and lenses. Instead, an exclusive cavity design conditions light to produce a highly controlled distribution pattern. Significant development efforts employing this new technology have given rise to a new benchmark in strobe performance – FullLight technology.

FullLight strobe technology produces a smooth light distribution pattern without the spikes and voids characteristic of specular reflectors. This ensures the entire coverage area receives consistent illumination from the strobe flash. As a result, Genesis strobes with FullLight technology go well beyond the minimum UL-required "cross" pattern, significantly exceeding UL-1971 and ULC-S526 light distribution requirements.

Depending on the model, clear lens Genesis ceiling strobes feature 15 to 95, or 95 to 177 candela output (see ordering information), which is selectable with a conveniently-located switch. The candela output setting remains clearly visible even after final installation, yet it is locked in place to prevent unauthorized movement after installation.

Genesis ECS/MNS appliances offer emergency signaling with clear or amber lenses and with optional ALERT housing labels. They are ideal for applications that require differentiation between life safety and mass notification alerts.

Standard Features

- **Field configurable – no need to remove the device!**
 - 15/30/75/95 cd and 95/115/150/177 cd clear strobe lens models available
 - Switch settings remain visible even after the unit is installed
- **ECS/MNS models available**
 - 13/26/65/82 and 82/100/130/155 (1971 equivalent) amber lens models available
- **Unique low-profile design**
 - 30 per cent slimmer profile than comparable signals
 - Attractive appearance
 - No visible mounting screws
 - Available with white or red housings
- **Easy to install**
 - Fits all standard 4" square electrical boxes with plenty of room behind the signal for extra wire – no extension ring or trim plate needed
 - #18 to #12 AWG terminals – ideal for long runs or existing wiring
- **Unparalleled performance**
 - Exclusive FullLight strobe technology produces the industry's most even light distribution
 - Precision timing electronics meet tough synchronizing standards for strobes
 - Low current draw minimizes system overhead
- **Approved for public and private mode applications**
 - UL 1971-listed as signaling devices for the hearing impaired
 - UL 1638-listed as protective visual signaling appliances
 - UL/ULC listed for ceiling or wall use

Application

Genesis strobes are UL 1971 or 1638 listed for indoor use. Prevailing codes require strobes to be used where ambient noise conditions exceed specified levels, where occupants use hearing protection, and in areas of public accommodation. Consult with your Authority Having Jurisdiction for details.

All Genesis strobes exceed UL synchronization requirements (within 10 milliseconds over a two-hour period) when used with a synchronization source. Synchronization for multiple strobe lights in a single field of view is required.

ECS/MNS Applications

Genesis ECS/MNS appliances bring the same high-performance life safety features and unobtrusive design to mass notification applications. Available as standard units with clear or amber lenses with optional ALERT markings, they are ideal for applications that require differentiation between life safety and ECS/MNS signals. Units are also available (special order) with red, blue or green lenses.

Installation

All models are intended for indoor applications only. Strobes mount to any flush North-American 4" square electrical box, 2 1/8" (54 mm) deep.

Genesis ceiling strobes simply unlatch and twist to open. This gains access to mounting screws and the selectable candela switch. The shallow depth of Genesis devices leaves ample room behind the signal for extra wiring. Once installed with the cover in place, no mounting screws are visible.

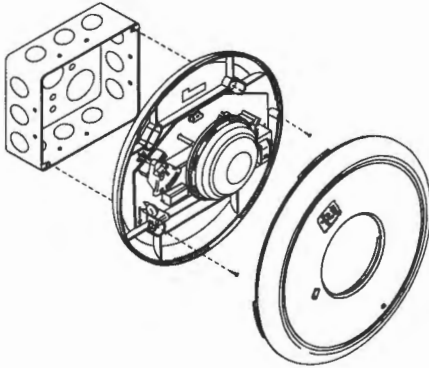

Wiring

Field wiring terminals accommodate #18 to #12 AWG (0.75 mm² to 2.5 mm²) wiring. Strobes are interconnected with a single pair of wires as shown below.

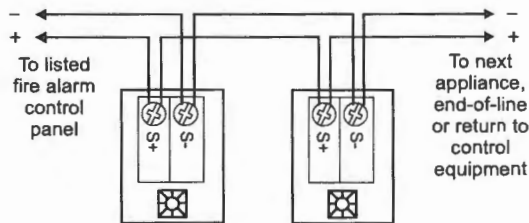

Dimensions

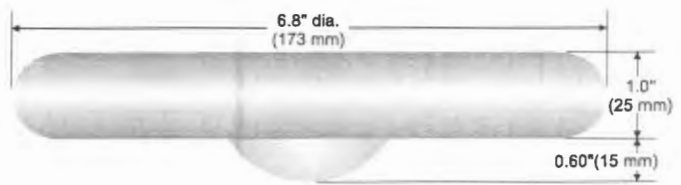

Light output (effective cd)

Percent of UL rating versus angle

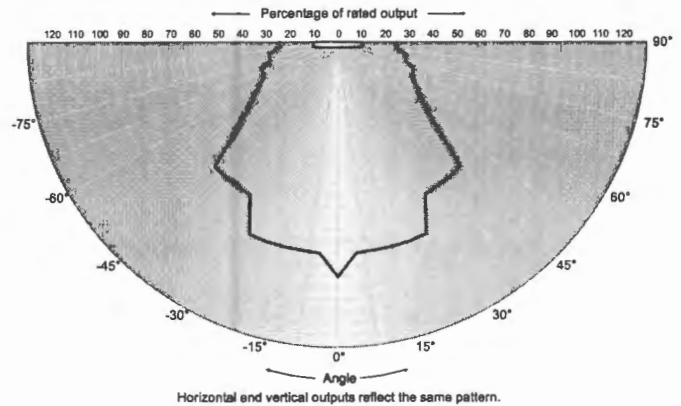

Field Configuration

Depending on the model, Genesis ceiling speaker-strobes have multi-candela output (see ordering information). The output setting is changed by simply opening the device and sliding the switch to the desired setting. The strobe does not have to be removed to change the output setting. The setting remains visible through a small window on the front of the device after the cover is closed.

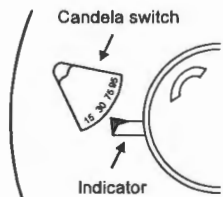

WARNING: These devices will not operate without electrical power. As fires frequently cause power interruptions, we suggest you discuss further safeguards with your local fire protection specialist.

Current Draw

Light output switch settings for UL 1971 listed models are selectable by numeric candela value. ECS/MNS appliances are selectable by A, B, C, or D designations.

UL Rating	Light output setting, standard models			
	"15" or "D"	"30" or "C"	"75" or "B"	"95" or "A"
	RMS	RMS	RMS	RMS
16 Vdc	109	151	281	318
16 Vfwr	131	194	379	437

Light output setting, high output models			
"95" or "D"	"115" or "C"	"150" or "B"	"177" or "A"
RMS	RMS	RMS	RMS
330	392	502	565
432	518	643	693

Typical Current	Light output setting, standard models			
	"15" or "D"	"30" or "C"	"75" or "B"	"95" or "A"
	RMS	RMS	RMS	RMS
16 Vdc	94	140	273	325
24 Vdc	74	108	168	244
33 Vdc	63	90	168	194
16 Vfwr	48	70	124	139
20 Vfwr	126	187	368	403
24 Vfwr	108	156	281	333
33 Vfwr	97	139	240	270
33 Vfwr	89	119	197	214

Light output setting, high output models			
"95" or "D"	"115" or "C"	"150" or "B"	"177" or "A"
RMS	RMS	RMS	RMS
333	392	499	551
259	303	378	429
212	245	306	342
155	180	211	236
484	570	673	724
380	438	537	604
318	361	434	484
245	269	308	338

Current values are shown in mA.

Specifications

Housing	Textured UV stabilized, color impregnated engineered plastic. Exceeds 94V-0 UL flammability rating. Red and white models available.
Lens	Optical grade polycarbonate (clear).
Mounting	Flush mount to North American 4-inch square electrical box, 2-1/8 (54 mm) inches deep. No extension ring required. Suitable for indoor wall or ceiling applications.
Wire Connections	Screw terminals: #18 to #12 AWG (0.75 mm ² to 2.5 mm ²) wire size.
Operating Voltage	Regulated 16 to 33 Vdc, 16 to 33 Vfwr.
Operating environment	Indoor: 32-120° F (0-49° C) ambient temperature; 0-93% relative humidity.
Agency listings/approvals	Meets or exceeds year 2004 UL requirements for standards UL1638 and UL1971 and Canadian requirements for standards CAN/ULC S526-02 and CAN/ULC S524-01. All models comply with ADA Code of Federal Regulation Chapter 28 Part 36 Final Rule. CSFM, MEA, FM pending.
Strobe output rating	UL 1971, UL 1638, ULC S526: selectable 15/30/75/95 cd (GC-VM) and 95/115/150/177 cd (GC-VMH)
Strobe operating voltage	GC-VM series strobes: non-coded, filtered 16-33 Vdc or unfiltered 16-33 Vdc FWR.
Strobe flash rate	GC-VM series strobes: one flash per second synchronized with optional G1M Genesis Signal Master indefinitely within 10 milliseconds. Temporal setting (private mode only): synchronized to temporal output of Genesis audible signals on same circuit.
Synchronization	Meets or exceeds UL 1971 requirements. Maximum allowed resistance between any two devices is 20 Ohms. Refer to specifications for the synchronization control module, this strobe, and the control panel to determine allowed wire resistance.
Synchronization Sources	SIGA-CC1S, SIGA-MCC1S, SIGA-CC2A, SIGA-MCC2A, G1M-RM BPS6A, BPS10A, APS6A, APS10A, iO64, iO500, Fireshield Plus 3, 5 and 10 zone. Add G1M for G1-CVM & G1-HDVM devices only.



Detection & alarm since 1872

U.S.
T 888 378 2329
F 866 503 3996

Canada
Chubb Edwards
T 519 376 2430
F 519 376 7258

Southeast Asia
T : +65 6391 9300
F : +65 6391 9306

India
T : +91 80 4344 2000
F : +91 80 4344 2050

Australia
T +61 3 9239 1200
F +61 3 9239 1299

Europe
T +32 2 725 11 20
F +32 2 721 86 13

Latin America
T 305 593 4301
F 305 593 4300

utcfireandsecurity.com

© 2010 UTC Fire & Security.
All rights reserved.

Ordering Information

Light output switch settings for UL 1971 listed models are selectable by numeric candela value.

ECS/MNS appliances are selectable by A, B, C, or D designations.

Model	Housing	Marking	Lens	Strobe	Ship Wt.
Life safety Appliances (c/w running man icon screen printed on housing)					
GC-VM	White	None	Clear	Selectable 15, 30, 75, or 95 cd	1.8 lb. (0.82 kg.)
GCF-VM	White	"FIRE"			
	Red	"FIRE"			
GC-VMH	White	None			
GCF-VMH	White	"FIRE"		Selectable high output 95, 115, 150, or 177 cd	

ECS/MNS Appliances (no running man icon on housing)

GCWA-VMA	White	"Alert"	Amber	Selectable A, B, C, D	1.8 lb. (0.82 kg.)
GCWA-VMC			Clear		
GCWN-VMA		None	Amber		
GCWN-VMC			Clear		
GCWA-VMHA		"Alert"	Amber	Selectable high output A, B, C or D	
GCWA-VMHC			Clear		
GCWN-VMHA		None	Amber		
GCWN-VMHC			Clear		

Units with red, blue or green lenses are available as a special order. Contact customer service for details.



Remote Booster Power Supplies

BPS6A, BPS10A



Overview

The Booster Power Supply (BPS) is a UL 864, 9th Edition listed power supply. It is a 24 Vdc filtered-regulated, and supervised unit that can easily be configured to provide additional notification appliance circuits (NACs) or auxiliary power for Mass Notification/ Emergency Communication (MNEC), as well as life safety, security, and access control applications.

The BPS contains the circuitry to monitor and charge internal or external batteries. Its steel enclosure has room for up to two 10 ampere-hour batteries. For access control-only applications, the BPS can support batteries totaling up to 65 ampere-hours in an external enclosure. The BPS has four Class B (convertible to two Class A) NACs. These can be activated in one or two groups from the BPS's unique dual input circuits.

The BPS is available in 6.5 or 10 ampere models. Each output circuit has a capacity of three amperes; total current draw cannot exceed the unit's rating.

The BPS meets current UL requirements and is listed under the following standards:

Standard (CCN)	Description
UL864 9th edition (UOXX)	Fire Alarm Systems
UL636 (ANET, UEHX7)	Holdup Alarm Units and Systems
UL609 (AOTX, AOTX7)	Local Burglar Alarm Units and Systems
UL294 (ALVY, UEHX7)	Access Control Systems
UL365 (APAW, APAW7)	Police Station Connected Burglar Alarm Units and Systems
UL1076 (APOU, APOU7)	Proprietary Burglar Alarm System Units
UL1610 (AMCX)	Central Station Alarm Unit
ULC-S527 (UOXXC)	Control Units, Fire Alarm (Canada)
ULC-S303 (AOTX7)	Local Burglar Alarm Units and Systems (Canada)
C22.2 No. 205	Signaling Equipment (Canada)

Standard Features

- Allows for reliable filtered and regulated power to be installed where needed
- Cost effective system expansion
- Provides for Genesis and Enhanced Integrity notification appliance synchronization
- Supports coded output operation
- Self-restoring overcurrent protection
- Multiple signal rates
- Can be cascaded or controlled independently
- Easy field configuration
- On-board diagnostic LEDs identify wiring or internal faults
- Standard Edwards keyed lockable steel cabinet with removable door
- 110 and 230 Vac models available
- Accommodates 18 to 12 AWG wire sizes
- Optional tamper switch
- Dual battery charging rates
- Optional earthquake hardening: OSHPD seismic pre-approval for component Importance Factor 1.5

Application

The BPS provides additional power and circuits for notification appliances and other 24 Vdc loads. It is listed for indoor dry locations and can easily be installed where needed.

Fault conditions are indicated on the on-board diagnostic LEDs, opening the BPS input sense circuit and the trouble relay (if programmed). While this provides indication to the host system, the BPS can still be activated upon command. A separate AC Fail contact is available on the BPS circuit board, which can be programmed for trouble or AC Fail. There are seven on-board diagnostic LEDs: one for each NAC fault, one for battery fault, one for ground fault, and one for AC power.

The unique dual-input activation circuits of the BPS can be activated by any voltage from 6 to 45 VDC (filtered-regulated) or 11 to 33 Vdc (full-wave rectified, unfiltered). The first input circuit can be configured to activate 1-4 of the four possible outputs. The second input circuit can be configured to control circuits 3 and 4. When outputs are configured for auxiliary operation, these circuits can be configured to stay on or automatically deactivate 30 seconds after AC power is lost. This feature makes these circuits ideal for door holder applications. The BPS also has a separate 200 mA 24 Vdc output that can be used to power internal activation modules.

BPS NACs can be configured for a 3-3-3 temporal or continuous output. California temporal rate outputs are also available on certain models. This makes the BPS ideal for applications requiring signaling rates that are not available from the main system.

In addition to the internally generated signal rates, the BPS can also be configured to follow the coded signal rate of the main system NACs. This allows for the seamless expansion of existing NACs.

The BPS enclosure has mounting brackets for up to three Signature modules to the right of the circuit board.

Engineering Specification

Supply, where needed, Edwards BPS Series Booster Power Supplies (BPS) that are interconnected to and supervised by the main system. The BPS shall function as a stand-alone auxiliary power supply with its own fully-supervised battery complement. The BPS battery complement shall be sized to match the requirements of the main system. The BPS shall be capable of supervising and charging batteries having the capacity of 24 ampere-hours for Mass Notification/Emergency Communication (MNEC), life safety and security applications, and the capacity of 65 ampere-hours for access control applications.

<<The BPS shall be capable of installation for a seismic component Importance Factor of 1.5.>> The BPS shall provide a minimum of four independent, fully supervised Class B circuits that can be field configurable for notification appliance circuits or auxiliary 24 Vdc power circuits. BPS NACs shall be convertible to a minimum of two Class A NACs. Each BPS output circuit shall be rated at 3 amperes at 24 Vdc. Each output circuit shall be provided with automatically restoring overcurrent protection. The BPS shall be operable from the main system NAC and/or Edwards Signature Series control modules. BPS NACs shall be configurable for continuous, 3-3-3 temporal or optionally, California rate. Fault conditions on the BPS shall not impede operation of main system NAC. The BPS shall be provided with ground fault detection circuitry and a separate AC fail relay.

Dimensions

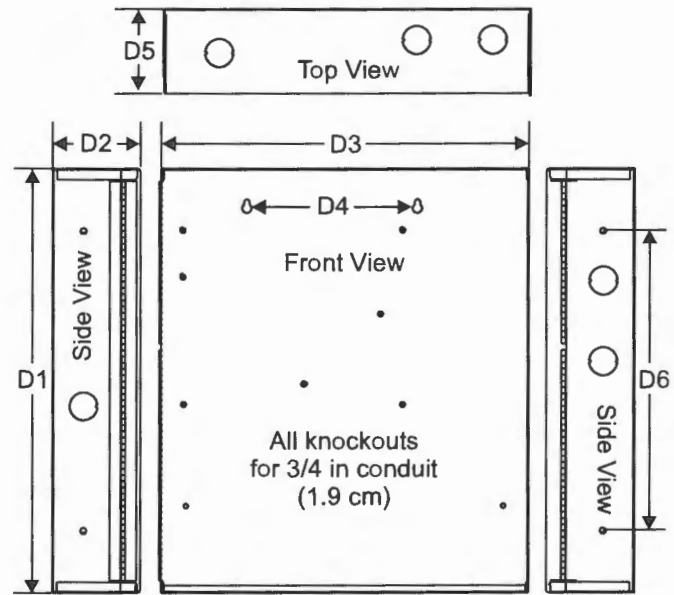

D1	D2	D3	D4	D5	D6
17.0 in (43.2 cm)	3.5 in (8.9 cm)	13.0 in (33.0 cm)	6.5 in (16.5 cm)	3.375 in (8.6 cm)	12.0 in (30.4 cm)

Wire routing

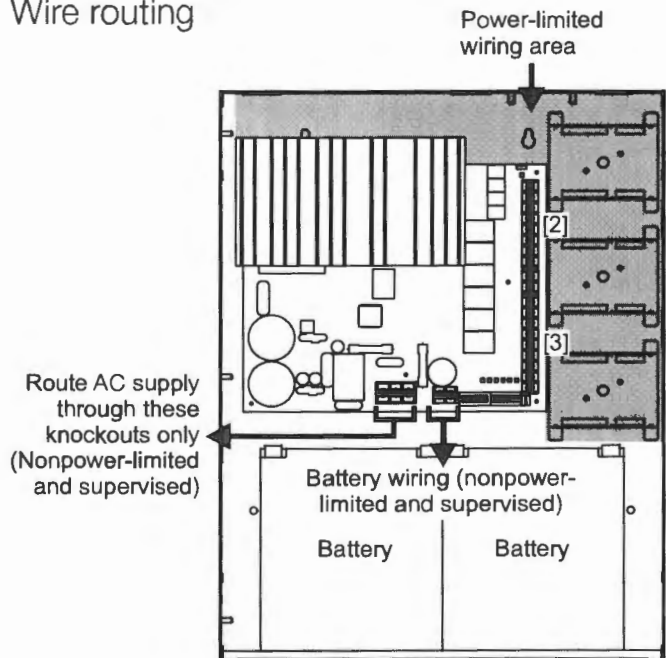

Notes

1. Maintain 1/4-inch (6 mm) spacing between power-limited and nonpower-limited wiring or use type FPL, FPLR, or FPLP cable per NEC.
2. Power-limited and supervised when not configured as auxiliary power. Non-supervised when configured as auxiliary power.
3. Source must be power-limited. Source determines supervision.
4. When using larger batteries, make sure to position the battery terminals towards the door.

Typical Wiring

Single or cascaded booster anywhere on a notification appliance circuit

Existing NAC end-of-line resistors are not required to be installed at the booster's terminals. This allows multiple boosters to be driven from a single NAC circuit without the need for special configurations.

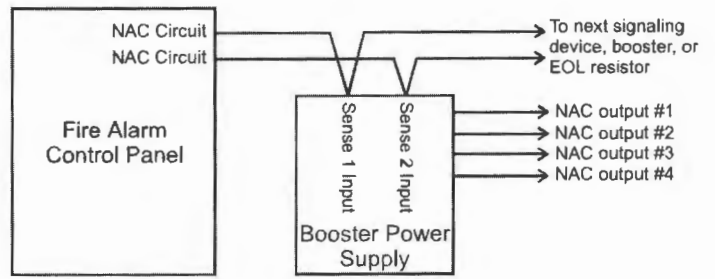

Configuring the Booster for AC Power Fail delay operation*

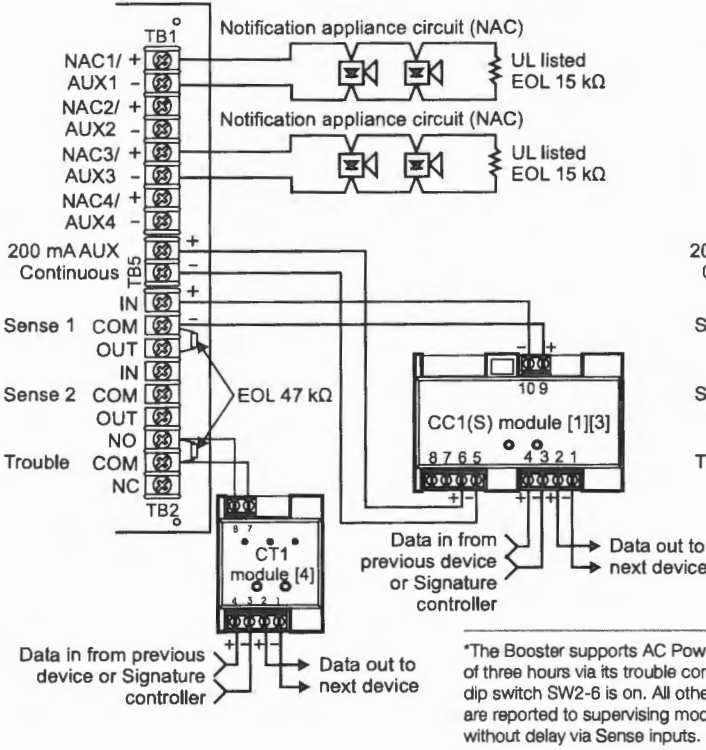

Multiple CC1(S) modules using the BPS's sense inputs

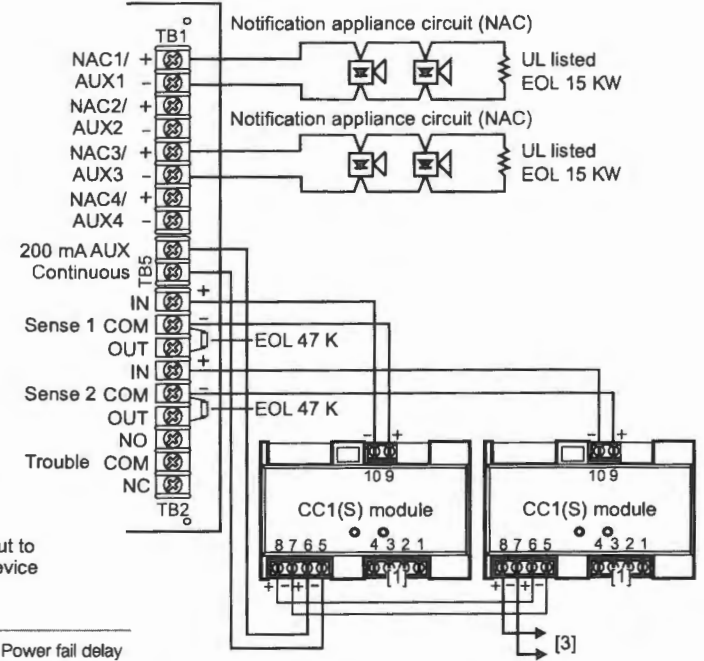

Security and access

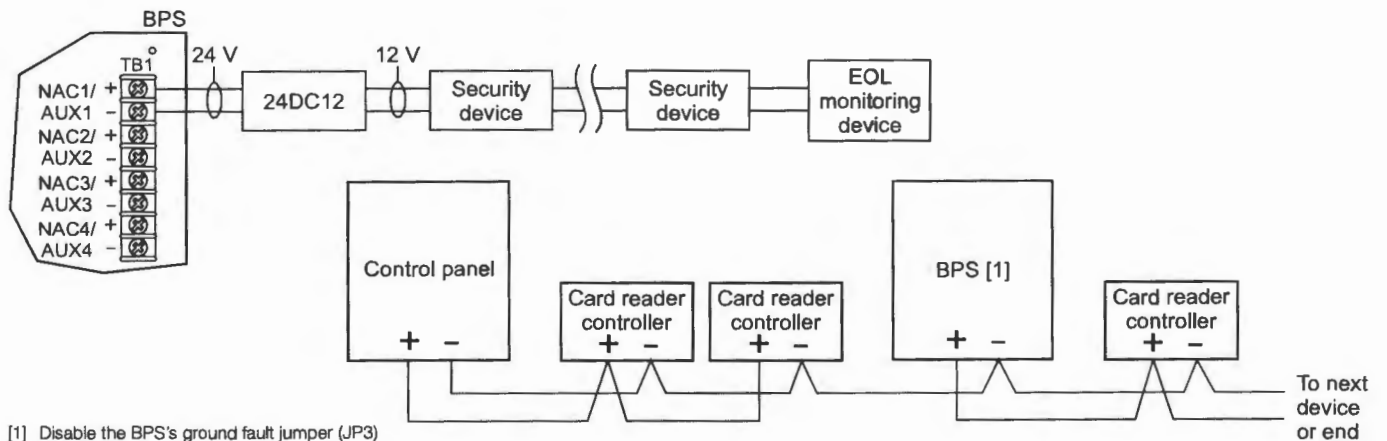



Detection & alarm since 1872

U.S.
T 888-378-2329
F 866-503-3996

Canada
Chubb Edwards
T 519 376 2430
F 519 376 7258

Southeast Asia
T : +65 6391 9300
F : +65 6391 9306

India
T : +91 80 4344 2000
F : +91 80 4344 2050

Australia
T +61 3 9239 1200
F +61 3 9239 1299

Europe
T +32 2 725 11 20
F +32 2 721 86 13

Latin America
T 305 593 4301
F 305 593 4300

utcfireandsecurity.com

© 2010 UTC Fire & Security.
All rights reserved.

Specifications

Model	6.5 amp Booster	10 Amp Booster
AC Line Voltage	120VAC or 220-240VAC 50/60Hz 390 watts	120VAC or 220-240VAC 50/60Hz 580 watts
Notification Appliance Circuit Ratings	3.0A max. per circuit @ 24Vdc nominal 6.5A max total all NACs	3.0A max. per circuit @ 24Vdc nominal 10A max total all NACs
Trouble Relay	2 Amps @ 30Vdc	
Auxiliary Outputs	Four configurable outputs replace NACs 1, 2, 3 or 4. as auxiliary outputs and 200 mA dedicated auxiliary. (See note 2.)	
Input Current (from an existing NAC)	3mA @ 12Vdc, 6mA @ 24Vdc	
Signature Mounting Space	Accommodates three two-gang modules.	
Maximum Battery Size	10 Amp Hours (2 of 12V10A) in cabinet up to 24 Amp hours with ex- ternal battery cabinet for fire and security applications; up to 65 Amp hours for access control applications in external battery box.	
Terminal Wire Gauge	18-12 AWG	
Relative Humidity	0 to 93% non condensing @ 32°C	
Temperature Rating	32° to 120°F (0° to 49°C)	
NAC Wiring Styles	Class A or Class B	
Output Signal Rates	Continuous, California rate, 3-3-3 temporal, or follow installed panel's NAC. (See note 1.)	
Ground Fault Detection	Enable or Disable via jumper	
Agency Listings	UL, ULC, CSFM	

1. Model BPS*CAA provides selection for California rate, in place of temporal.
2. Maximum of 8 Amps can be used for auxiliary output.

Ordering Information

Catalog Number	Description	Shipping Wt. lb (kg)
BPS6A	6.5 Amp Booster Power Supply	13 (5.9)
BPS6AC	6.5 Amp Booster Power Supply (ULC)	13 (5.9)
BPS6A/230	6.5 Amp Booster Power Supply (220V)	13 (5.9)
BPS6CAA	6.5 Amp Booster Power Supply with California rate	13 (5.9)
BPS10A	10 Amp Booster Power Supply	13 (5.9)
BPS10AC	10 Amp Booster Power Supply (ULC)	13 (5.9)
BPS10A/230	10 Amp Booster Power Supply (220V)	13 (5.9)
BPS10CAA	10 Amp Booster Power Supply with California rate	13 (5.9)

Related Equipment

12V6A5	7.2 Amp Hour Battery, two required	3.4 (1.6)
12V10A	10 Amp Hour Battery, two required	9.5 (4.3)
3-TAMP	Tamper switch	
BC-1EQ	Seismic Kit for BC-1. Order BC-1 separately. See note 3.	
BPSEQ	Seismic kit for BPS6A or BPS10 Booster Power Supplies. See note 3	
BC-1	Battery Cabinet (up to 2 - 40 Amp Hour Batteries)	58 (26.4)
BC-2	Battery Cabinet (up to 2 - 17 Amp Hour Batteries)	19 (8.6)
12V17A	18 Amp Hour Battery, two required (see note 1)	13 (5.9)
12V24A	24 Amp Hour Battery, two required (see note 1)	20 (9.07)
12V40A	40 Amp Hour Battery, two required (see notes 1, 2)	32 (14.5)
12V50A	50 Amp Hour Battery, two required (see notes 1, 2)	40 (18.14)
12V65A	65 Amp Hour Battery, two required (see notes 1, 2)	49 (22.2)

1. Requires installation of separate battery cabinet.
2. BPS supports batteries greater than 24 Amp hours for access control applications only.
3. For earthquake anchorage, including detailed mounting weights and center of gravity detail, refer to Seismic Application Guide 3101676. Approval of panel anchorage to site structure may require local AHJ, structural or civil engineer review.

Sealed Lead-Acid Batteries

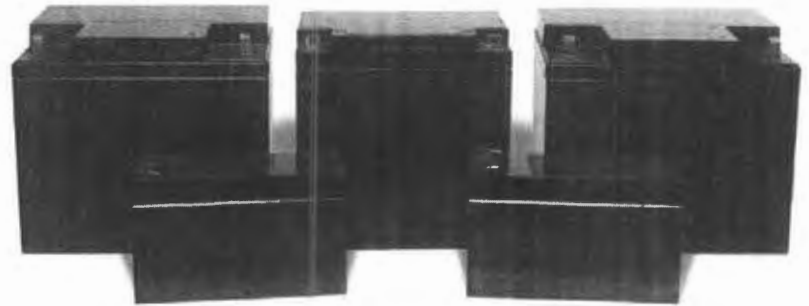

Overview

Rechargeable sealed lead-acid batteries are ideal for use as a secondary (standby) power source as defined by NFPA 72. Their low maintenance and high energy density make them ideal for fire alarm signaling applications.

Standard Features

- Rechargeable
- Non-spillable
- Non-hazardous
- Low maintenance
- High energy density

Application

When multiple power supplies are provided, each power supply's battery requirements should be calculated individually. Consult the specific system manual to determine battery capacity requirements.

Safety Information

Due to a battery's low internal resistance and high power density, high levels of short circuit current can develop across battery terminals. Put on protective eye covering and remove all jewelry before working on batteries. Do not rest tools or cables on the battery, and only use insulated tools. Follow all manufacturers installation instructions and diagrams when installing or maintaining batteries.



Detection & alarm since 1872

U.S.
T 888-378-2329
F 866-503-3996

Canada
Chubb Edwards
T 519 376 2430
F 519 376 7258

Southeast Asia
T : +65 6391 9300
F : +65 6391 9306

India
T : +91 80 4344 2000
F : +91 80 4344 2050

Australia
T +61 3 9239 1200
F +61 3 9239 1299

Europe
T +32 2 725 11 20
F +32 2 721 86 13

Latin America
T 305 593 4301
F 305 593 4300

utcfireandsecurity.com

© 2010 UTC Fire & Security.
All rights reserved.

Specifications

Case Material	ABS Thermoplastic
Regulatory Information	DOT Class 60, Batteries, non-hazardous, non-spillable
Operating Environment	32° F to 120° F (0° C to 49° C) 0 to 93% RH, Non-condensing

Ordering Information

Catalog Number	Description	Shipping Weight, lb (kg)
12V1A2	1.2 Ah Sealed Lead Acid Battery - 12 Vdc	1.25 (0.57)
12V4A	4.5 Ah Sealed Lead Acid Battery - 12 Vdc	5 (2.27)
12V6A	6 Ah Sealed Lead Acid Battery - 12 Vdc	6 (2.72)
6V8A	8 Ah Sealed Lead Acid Battery - 6 Vdc	4 (1.81)
6V10A	12 Ah Sealed Lead Acid Battery - 6 Vdc	5 (2.27)
12V10A	11 Ah Sealed Lead Acid Battery - 12 Vdc	10 (4.45)
12V17A	18 Ah Sealed Lead Acid Battery - 12 Vdc	13 (5.90)
12V24A	26 Ah Sealed Lead Acid Battery - 12 Vdc	20 (9.07)
12V40A	40 Ah Sealed Lead Acid Battery - 12 Vdc	32 (14.51)
12V50A	50 Ah Sealed Lead Acid Battery - 12 Vdc	40 (18.14)
12V65A	65 Ah Sealed Lead Acid Battery - 12 Vdc	49 (22.23)



P.O. Box 770
 131 Lafayette Rd.
 No. Hampton, NH 03862

QUOTATION

Date 04/05/11
 6/27/2011 revised 7-28-2011 revised 12-16-2011
 To L&B ELECTRIC
 JIM LAMSON

FOR INFORMATION CONCERNING THIS QUOTATION
 PLEASE CONTACT SALES OFFICE
 NE Toll Free 1-800-258-7264
 FAX (603) 964-8885
 We are pleased to quote you on our products as follows:

For WEST GATE ANYTIME FITNESS
EST Fire Alarm UPGRADES

191 B19

ITEM	QUANTITY	DESCRIPTION	UNIT PRICE	TOTAL
1		EST Fire Alarm System anytime fitness & RADIOBOX		
2		graphic map final pricing	\$	
3		CVS 2pulls, 4 horn/strobes, 6 strobes+ shared booster*	\$	
4		AUTO 2pulls, 5 horn/strobes, 5 strobes+shared booster*	\$	
5		LAUNDRY 2pulls, 3 horn/strobes, 3 strobes+ shared booster*	\$	
6		Additional pull at FACP exit	\$	
		Programming, Testing, Training, Warranty, 4 additional tech days		

SCANNED

shipping est \$75-\$100



Terms: Net 30 days, subject to credit approval.

Unless otherwise stated, applicable and local taxes are not included.

Note: The conditions of sale printed on the reverse side of this form constitute a part of this quotation.

WE BELIEVE QUANTITIES SHOWN IN THIS ESTIMATE ARE CORRECT. IN THE INTEREST OF COMPLETE ACCURACY PLEASE CHECK AGAINST YOUR OWN TAKE-OFF AND NOTIFY US OF ANY DISCREPANCY BEFORE BIDDING SO WE CAN REVISE OUR QUOTE TO YOU.

R. B. ALLEN CO., INC.

By: TIM BIRON
 1-207-657-2457 VOICE/FAX

220 9100



PORTLAND MAINE

Strengthening a Remarkable City, Building a Community for Life • www.portlandmaine.gov

Receipts Details:

Tender Information: Check , BusinessName: L & B Electrical Contractors Inc., Check
Number: 9001

Tender Amount: 170.00

Receipt Header:

Cashier Id: gguertin

Receipt Date: 3/13/2012

Receipt Number: 41703

Receipt Details:

Referance ID:	5584	Fee Type:	BP-Constr
Receipt Number:	0	Payment Date:	
Transaction Amount:	170.00	Charge Amount:	170.00
Job ID: Job ID: 2012-03-3496-FAFS -			
Additional Comments: 1364 Congress			

Thank You for your Payment!