

PARTITION LEGEND

STL STUD SIZES

0	7/8" FURRING CHANNEL
1	1/2" STUD
2	1/2" STUD
3	1/2" STUD
4	1/2" STUD
5	1/2" STUD
6	1/2" STUD
7	1/2" STUD
8	1/2" STUD

STL STUD SIZE (SEE DTLS LEFT)

GENERAL PARTITION NOTES:

- SEE DETAILS AT LEFT FOR FINISHING TOP OF PARTITIONS.
- ALL PARTITIONS SHALL BE CONSTRUCTED AS DESCRIBED IN THE PARTITION LEGEND.
- ALL PIPE, CONDUIT, DUCT, ETC., PENETRATIONS THRU WALLS, PARTITIONS, AND FIRESTOPS SHALL BE SEALED TIGHT AROUND PENETRATIONS.
- ALL PLYWOOD, WOOD VALERS AND WOOD BLOCKING SHALL BE FIRE-RETARDANT TREATED.
- ALL GPDW TO BE TYPE "X".

PARTITION LEGEND

1" = 1'-0" 0 2' 4' 8' 1' 1 1/2' REF: NA

D4

ROOM FINISH SCHEDULE

AREA	ROOM NO.	ROOM NAME	FLOOR	BASE		WALLS						CEILING			REMARKS			
				MAT	COLOR NO.	NORTH	COLOR NO.	EAST	COLOR NO.	SOUTH	COLOR NO.	WEST	COLOR NO.	MAT		COLOR NO.	HT	
	100	OFFICE #1	VCT			4" VINYL		GPDW PNT.		GPDW PNT.		GPDW PNT.		GPDW PNT.	ACT		8'-0"	
	101	OFFICE #2	VCT			4" VINYL		GPDW PNT.		GPDW PNT.		GPDW PNT.		GPDW PNT.	ACT		8'-0"	
	102	RECEIVING	VCT			4" VINYL		GPDW PNT.		GPDW PNT.		GPDW PNT.		GPDW PNT.	ACT		10'-0" 8'-0"	
	103	CLOSET	VCT			4" VINYL		GPDW PNT.		GPDW PNT.		GPDW PNT.		GPDW PNT.	ACT		8'-0"	
	104	LOUNGE	VCT			4" VINYL		GPDW PNT.		GPDW PNT.		GPDW PNT.		GPDW PNT.	ACT		8'-0"	
	105	OFFICE #3	VCT			4" VINYL		GPDW PNT.		GPDW PNT.		GPDW PNT.		GPDW PNT.	ACT		8'-0"	
	106	DATA/ELEC	VCT			4" VINYL		GPDW PNT.		GPDW PNT.		GPDW PNT.		GPDW PNT.	ACT		8'-0"	
	107	TOILET ROOM #1	VCT			4" VINYL	FRP	FRP	FRP	FRP	FRP	FRP	FRP	FRP	ACT		8'-0"	
	108	EQUIPMENT ROOM #2	EXPOSED CONCRETE SEALED			4" VINYL		GPDW PNT.		GPDW PNT.		GPDW PNT.		GPDW PNT.	EXP. STRUCT.			
	109	TOILET ROOM #2	VCT			4" VINYL	FRP	FRP	FRP	FRP	FRP	FRP	FRP	FRP	ACT		8'-0"	
	110	CORRIDOR	VCT			4" VINYL		GPDW PNT.		GPDW PNT.		GPDW PNT.		GPDW PNT.	ACT		10'-0"	
	111	EQUIPMENT #1	EXPOSED CONCRETE SEALED			GPDW/PWD PNT.		GPDW/PWD PNT.		GPDW/PWD PNT.		GPDW/PWD PNT.		GPDW/PWD PNT.	EXP. STRUCT.			3/4" PLYWOOD UP 8'-0" VERTICAL
	112	PARTS ROOM	EXPOSED CONCRETE SEALED			GPDW PNT.		GPDW PNT.		GPDW/PWD PNT.		GPDW/PWD PNT.		GPDW PNT.	EXP. STRUCT.			3/4" PLYWOOD UP 8'-0" VERTICAL

HARRIMAN
Architects + Engineers

One Auburn Business Park
Auburn, Maine 04210
207.784.5100 ext.
207.783.3017 fax

66 Pearl St., Suite 301
Portland, Maine 04101
207.775.0053 tel
207.775.0460 fax

www.harriman.com
© 2008

Project Title

WESTGATE SHOPPING CENTER SHAW'S MAINTENANCE

PORTLAND, ME

NA Project No. **07182**

Key Plan

DOOR AND FRAME SCHEDULE

AREA	No.	DOOR			FRAME			FIRE RATING	HDW SET	REMARKS
		SIZE	MAT	TYPE	GLASS	LOUVER	MAT			
	100	3'-0"	7'-0"	1 3/4"	WOOD	G	TEMP			
	101	3'-0"	7'-0"	1 3/4"	WOOD	G	TEMP			
	102A	3'-0"	7'-0"	1 3/4"	HM	G	TEMP			NEW DOOR IN EXISTING FRAME
	102B	6'-0"	8'-0"		MET	OH				
	103	2'-6"	7'-0"	1 3/4"	WOOD	F				
	104	3'-0"	7'-0"	1 3/4"	HM	G	TEMP			
	105	3'-0"	7'-0"	1 3/4"	WOOD	G	TEMP			
	106	3'-0"	7'-0"	1 3/4"	WOOD	F				
	107	3'-0"	7'-0"	1 3/4"	WOOD	F				
	108	3'-0"	7'-0"	1 3/4"	WOOD	F		90 MIN		
	109	3'-0"	7'-0"	1 3/4"	WOOD	F				
	112	3'-0"	7'-0"	1 3/4"	HM	F				

DOOR HARDWARE:

HARDWARE SET #1—DOORS NO. 100, 101, 105
1 LOCKSET (OFFICE FUNCTION)
3 HINGES
1 DOORSTOP

HARDWARE SET #2—DOORS NO. 103, 104, 106, 108
1 LATCHSET
3 HINGES
1 DOORSTOP

HARDWARE SET #3—DOORS NO. 107, 109
1 LOCKSET (PRIVACY FUNCTION)
3 HINGES

HARDWARE SET #4—DOOR NO. 102A
1 EXIT DEVICE
3 HINGES
1 CLOSER
1 THRESHOLD
1 WEATHERSEAL
1 STOP

HARDWARE AND ACCESSORIES SET #5—DOOR NO. 102B
1 RITE-ITE INSULATED SECTIONAL DOOR
1 3" GALVANIZED STEEL TRACK SYSTEM
1 WEATHERSEAL
1 HEAVY DUTY RUST-RESISTANT HARDWARE

HARDWARE SET #6—DOOR NO. 112
1 EXIT DEVICE (NO OUTSIDE HARDWARE)
3 HINGES
1 CLOSER
1 THRESHOLD
1 WEATHERSEAL
1 STOP

NOTES:
1. WOOD DOORS TO BE SOLID CORE PAINT GRADE.
2. LOCKSETS/LATCHSETS TO BE SCLAGE.
VERIFY FINISH WITH SHAW'S MAINTENANCE.

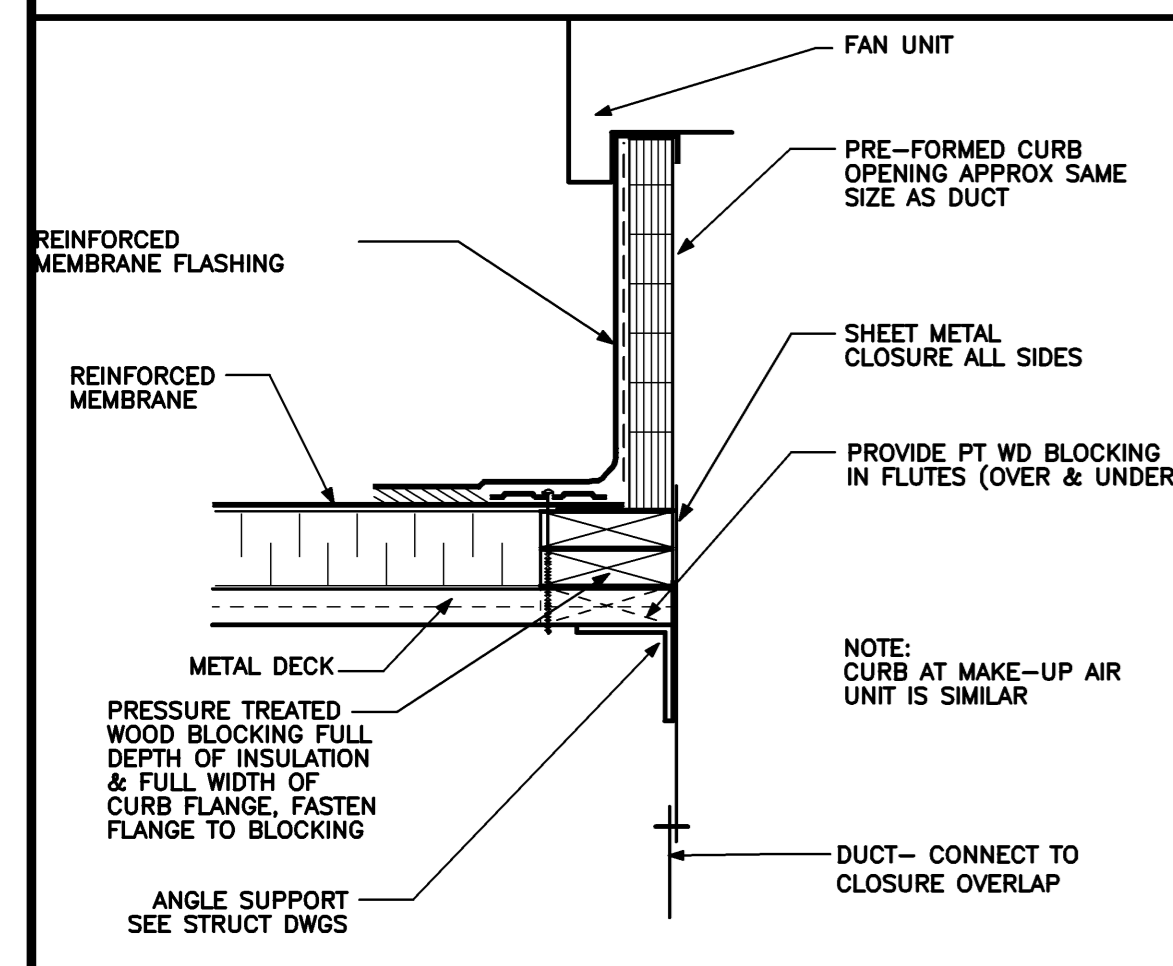

EXHAUST FAN CURB DETAIL

1 1/2" = 1'-0" 0 4' 8' 1' REF: NA

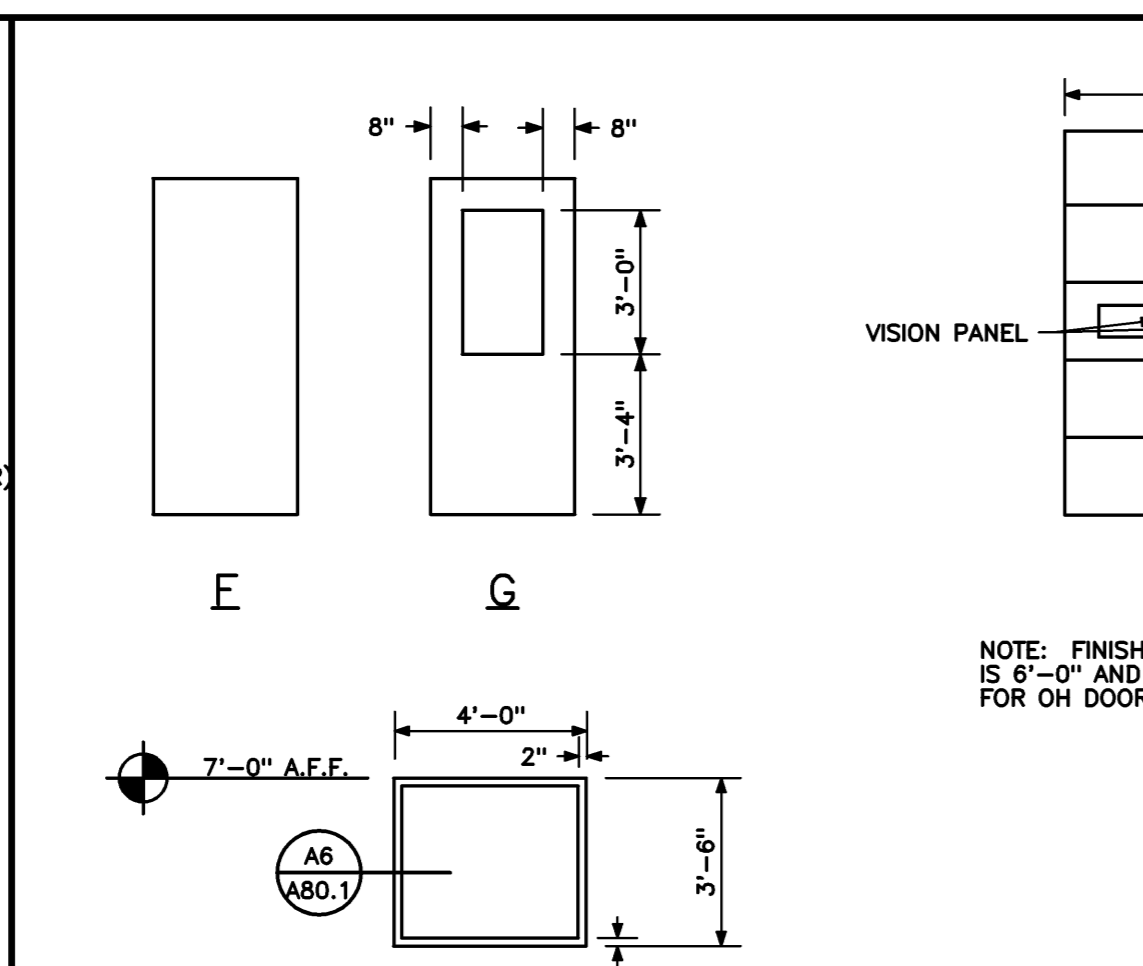

INTERIOR WINDOW AT OFFICE #2

1 1/2" = 1'-0" 0 4' 8' 1' REF: NA

DOOR TYPES AND FRAMES

1 1/4" = 1'-0" 0 2' 4' 8' 1' REF: NA

E4

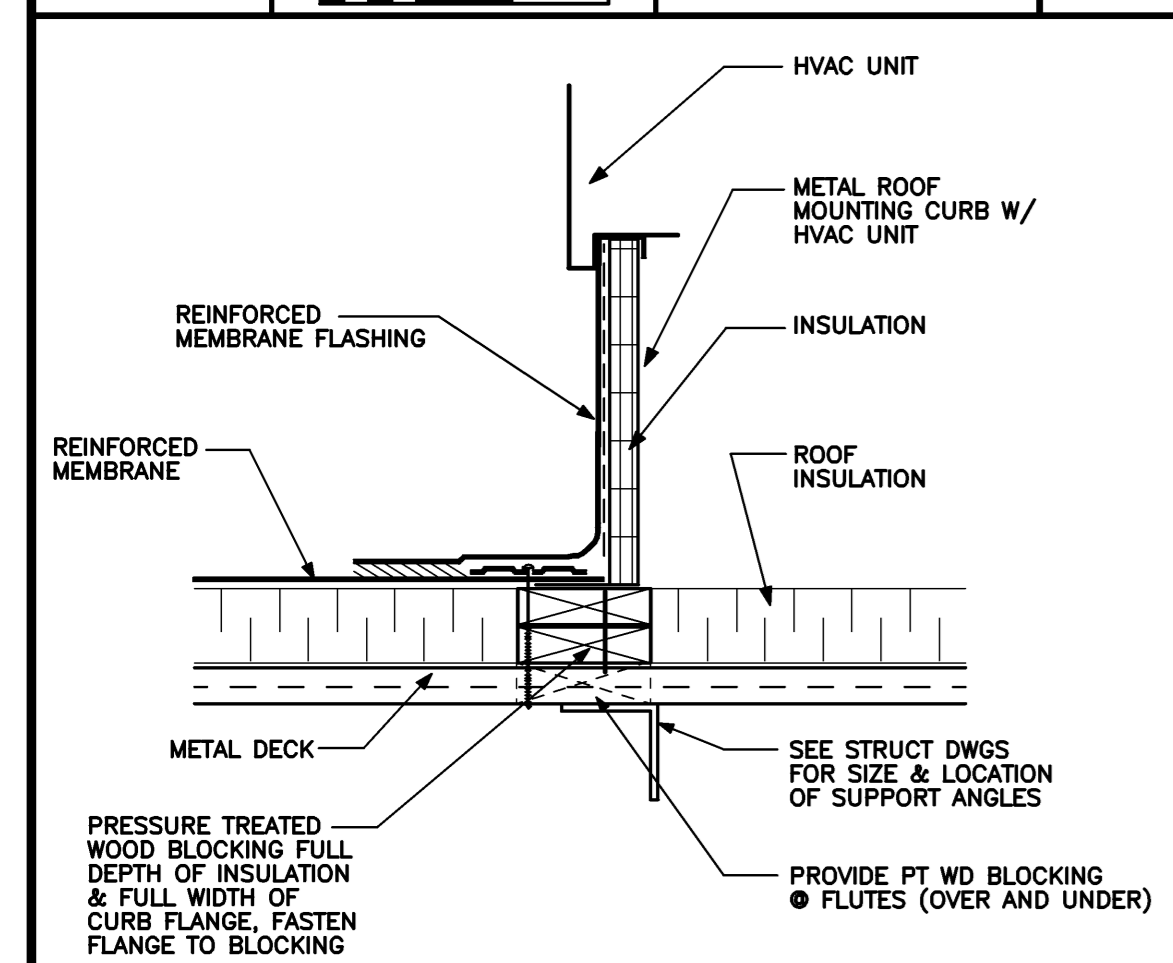

HVAC CURB DETAIL

1 1/2" = 1'-0" 0 4' 8' 1' REF: NA

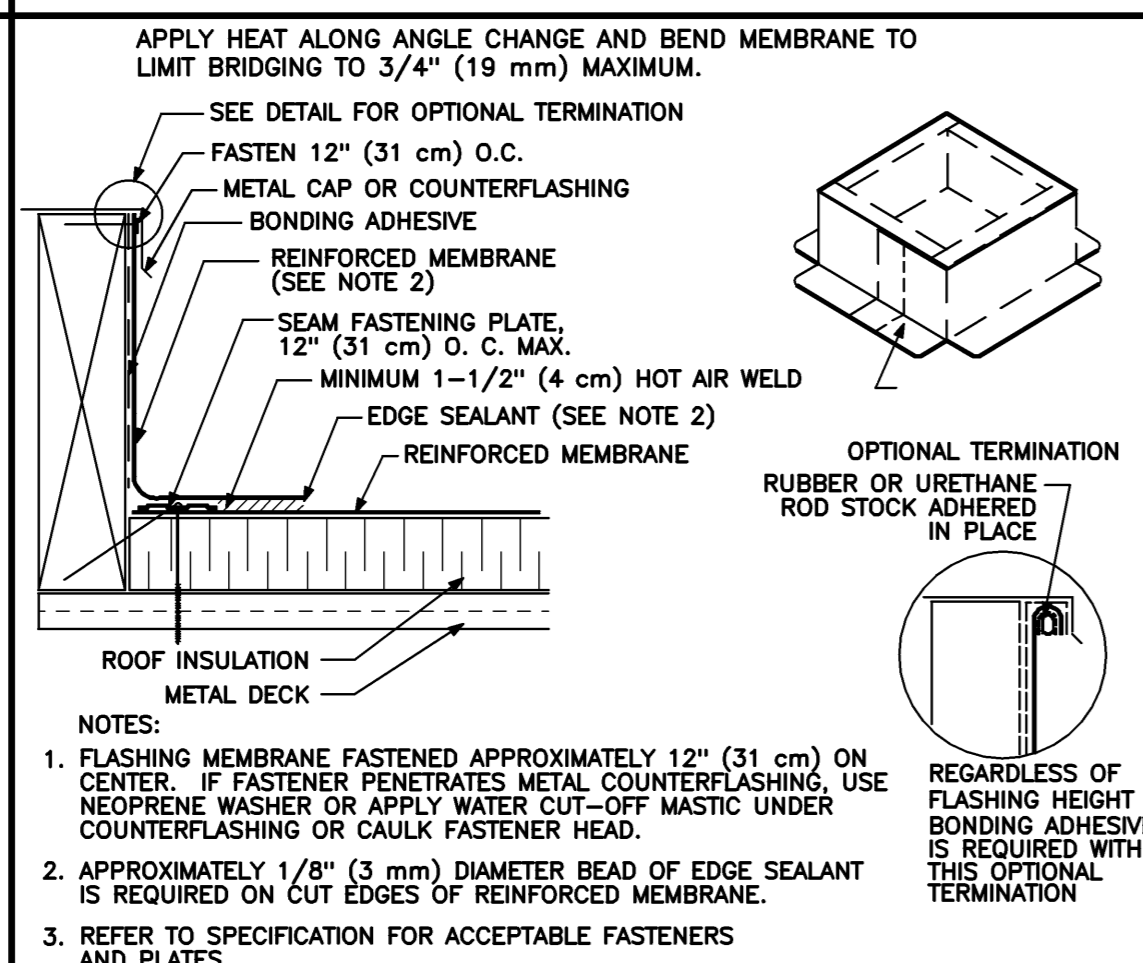

CURB FLASHING DETAIL

1 1/2" = 1'-0" 0 4' 8' 1' REF: NA

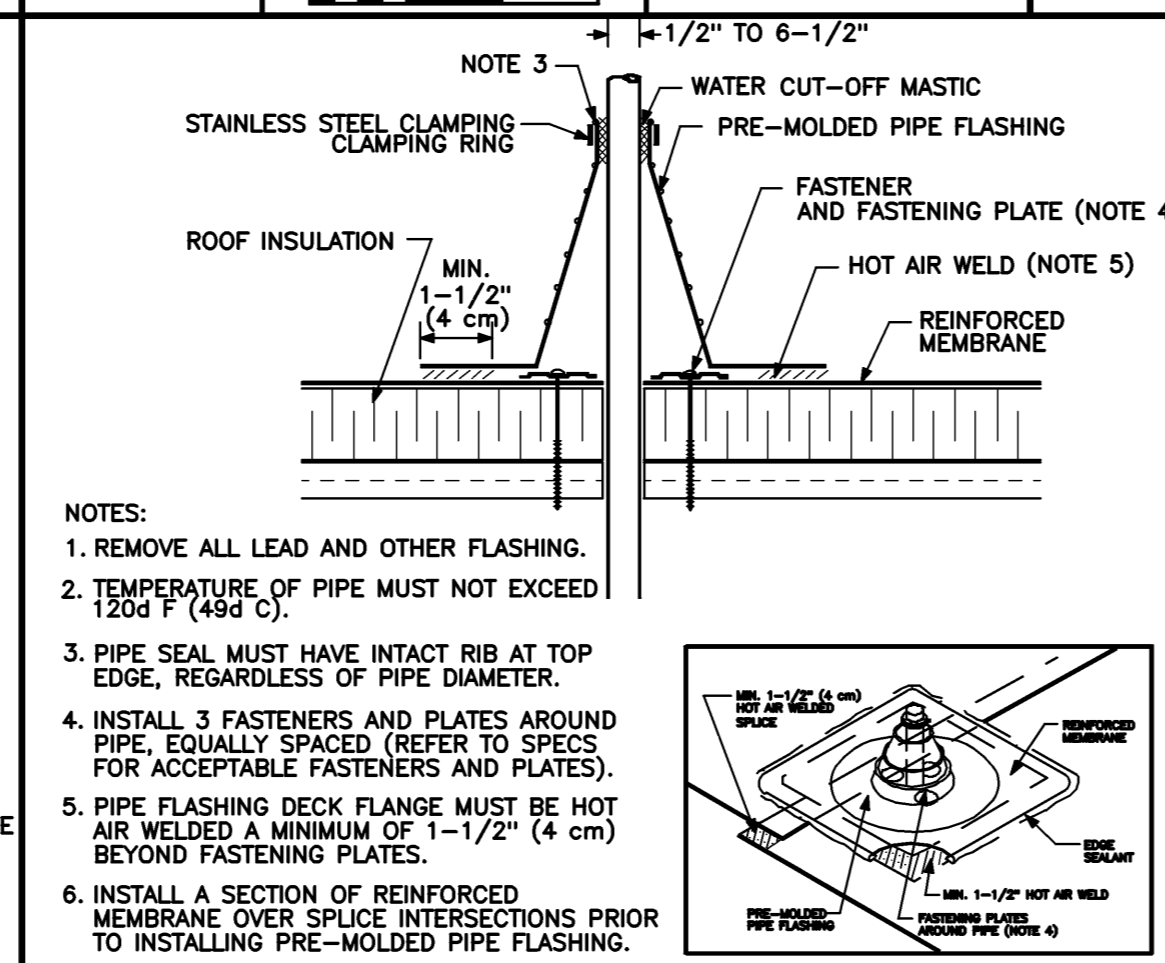

PIPE/VENT FLASHING DETAIL

1 1/2" = 1'-0" 0 4' 8' 1' REF: NA

C4

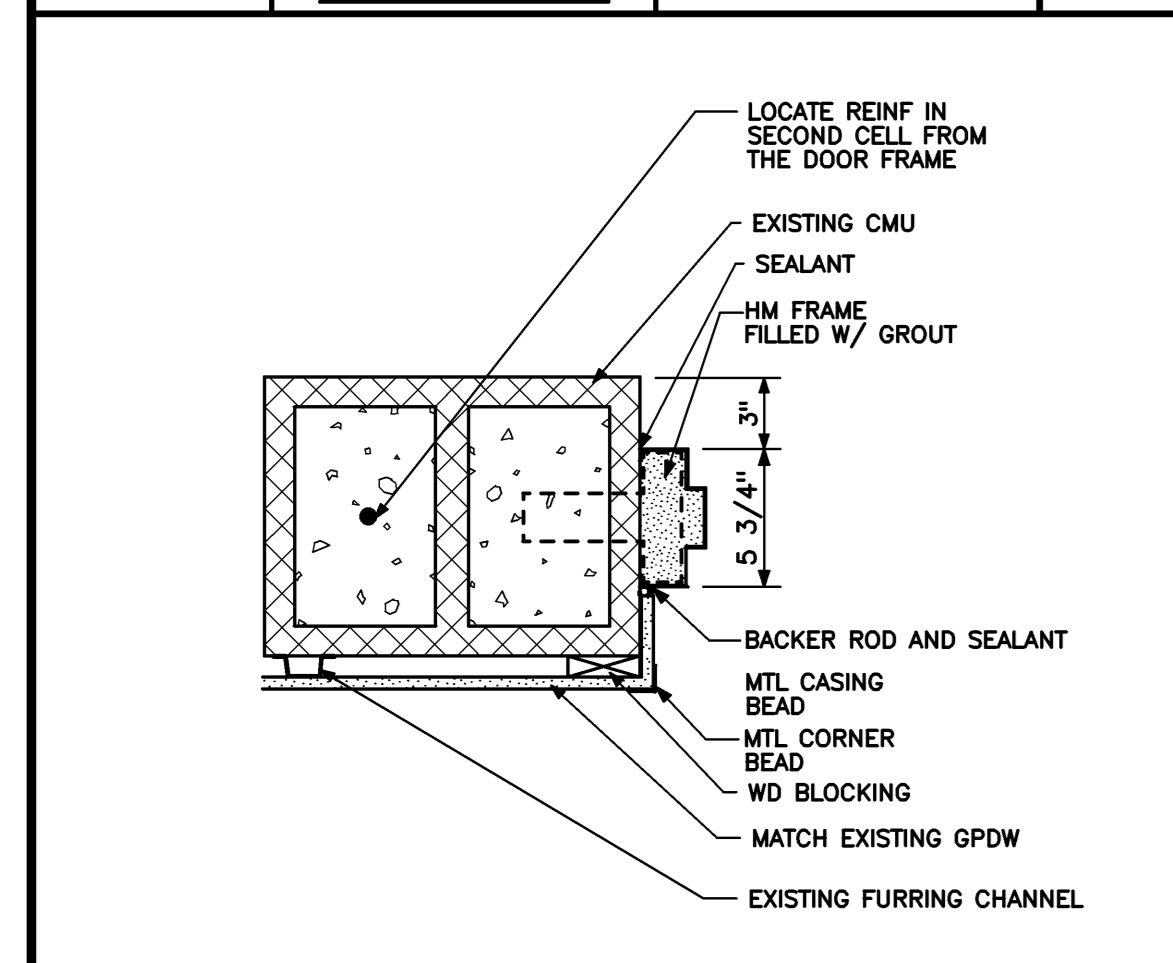

JAMB DETAIL

1 1/2" = 1'-0" 0 4' 8' 1' REF: NA

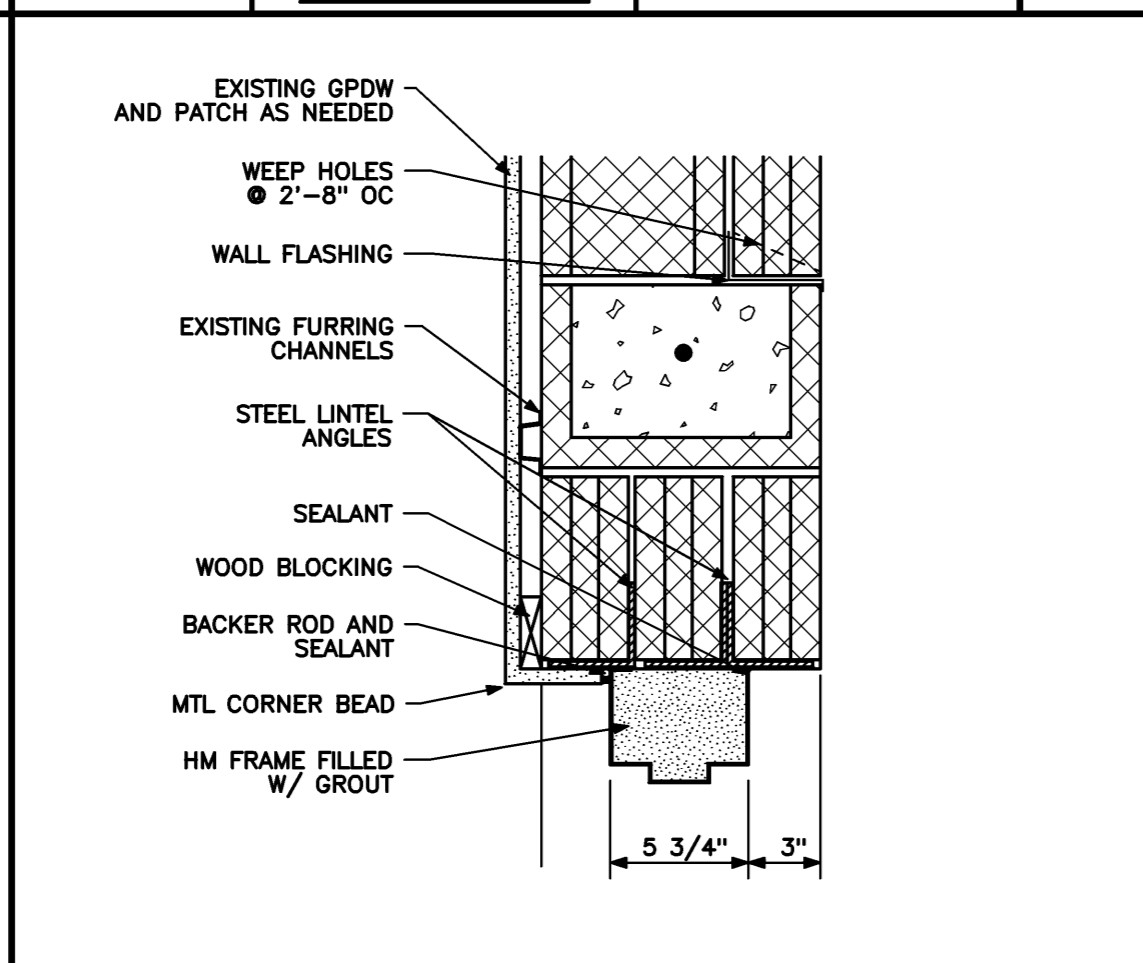

HEAD DETAIL

1 1/2" = 1'-0" 0 4' 8' 1' REF: NA

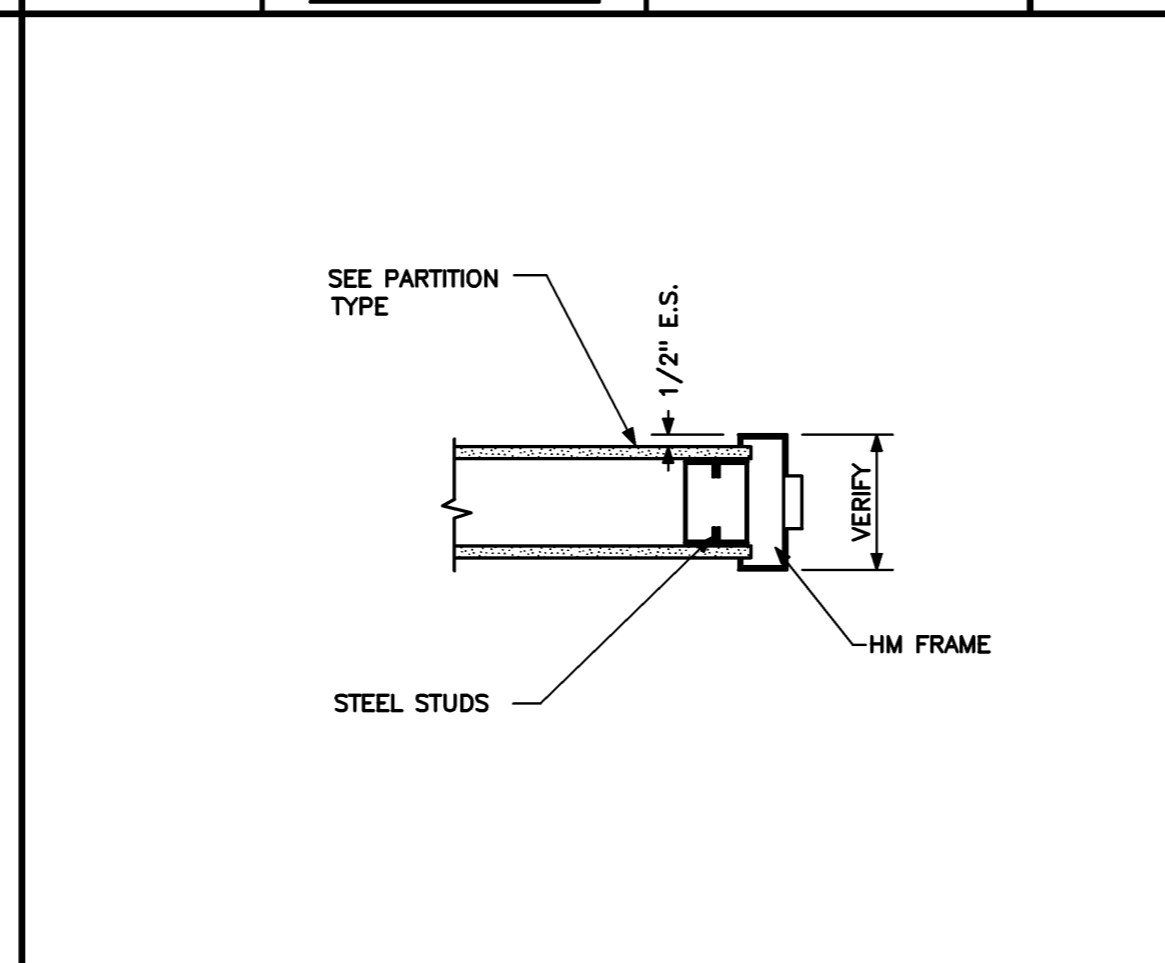

JAMB DETAIL

1 1/2" = 1'-0" 0 4' 8' 1' REF: NA

J2

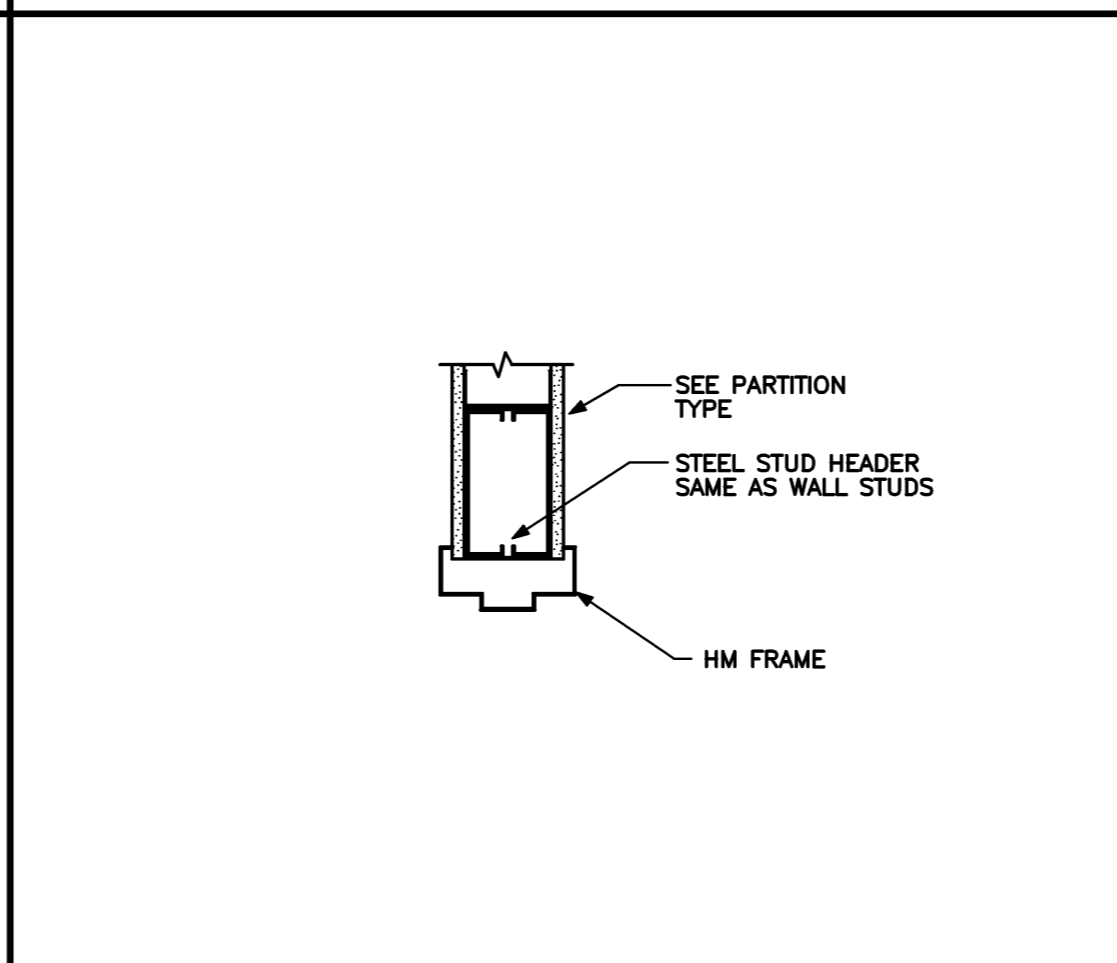

HEAD DETAIL

1 1/2" = 1'-0" 0 4' 8' 1' REF: NA

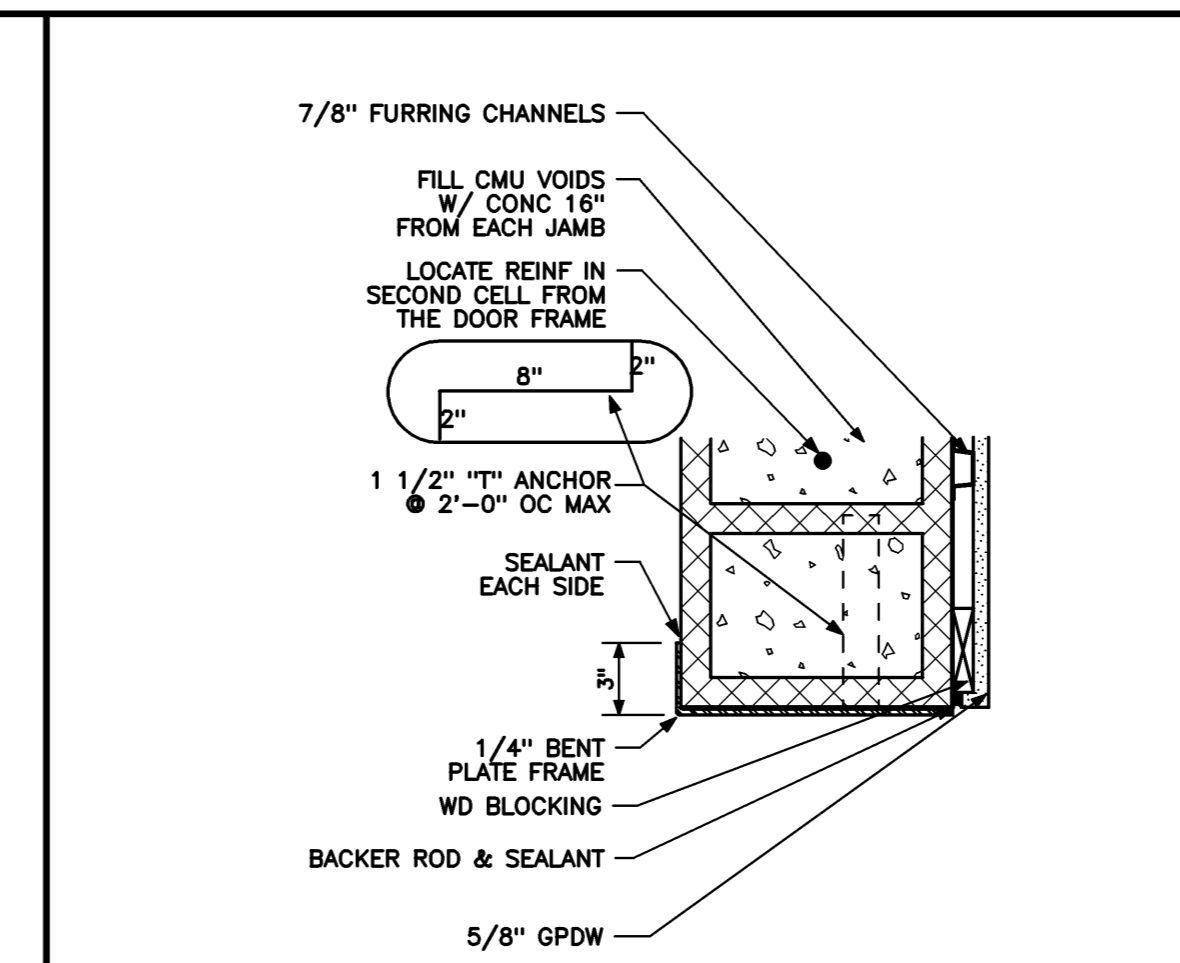

JAMB DETAIL

1 1/2" = 1'-0" 0 4' 8' 1' REF: NA

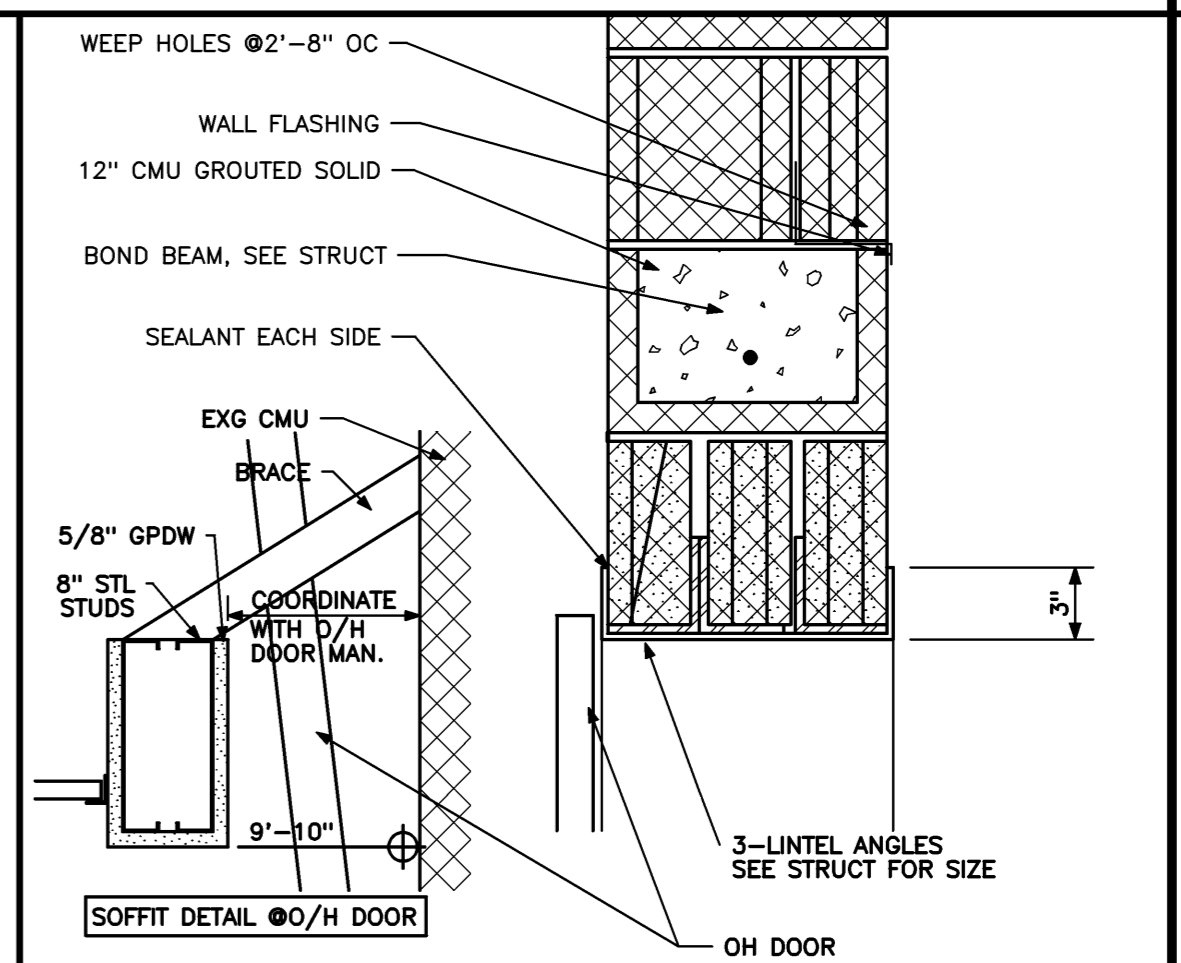

HEAD DETAIL & O/H DOOR SOFFIT DETAIL

1 1/2" = 1'-0" 0 4' 8' 1' REF: NA

H1

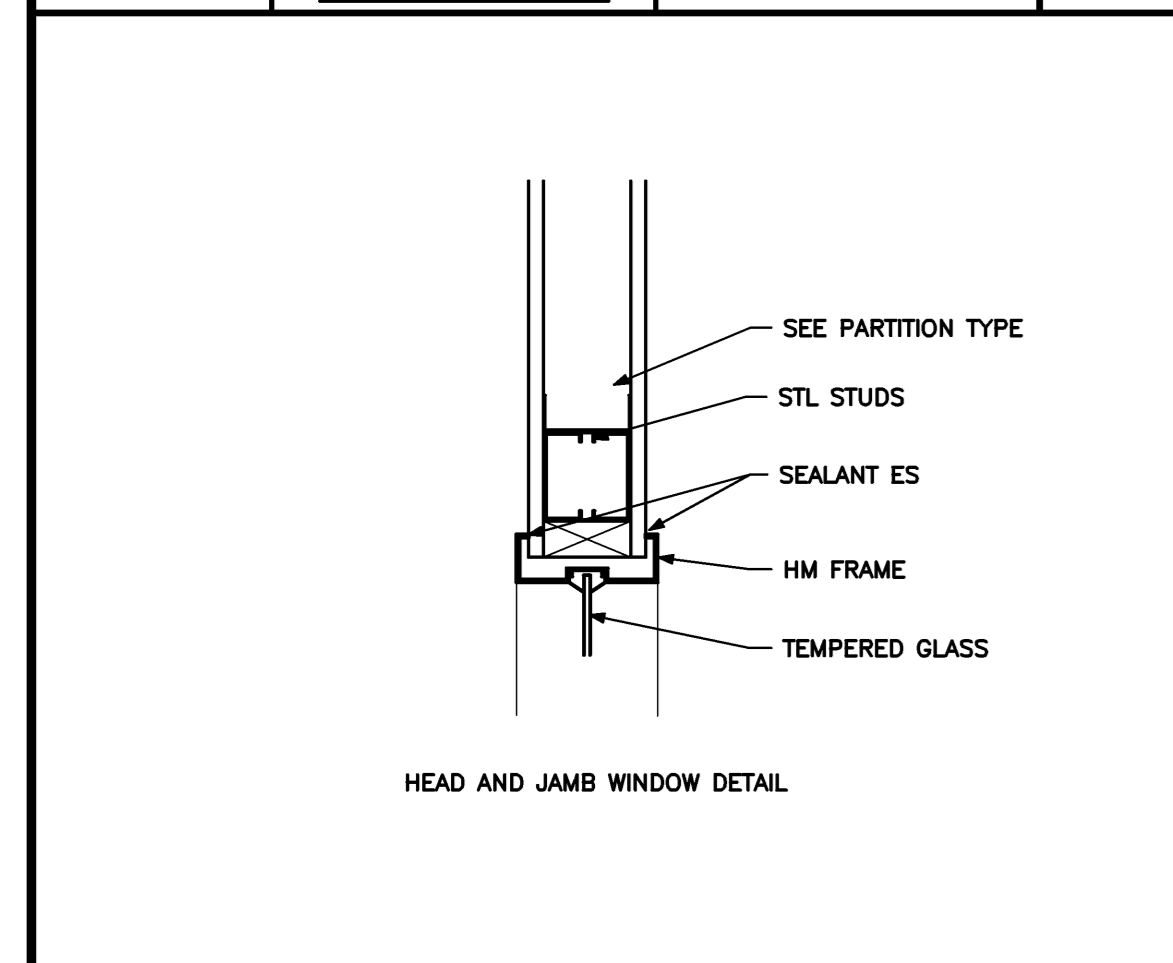

WINDOW DETAIL

1 1/2" = 1'-0" 0 4' 8' 1' REF: A10.1

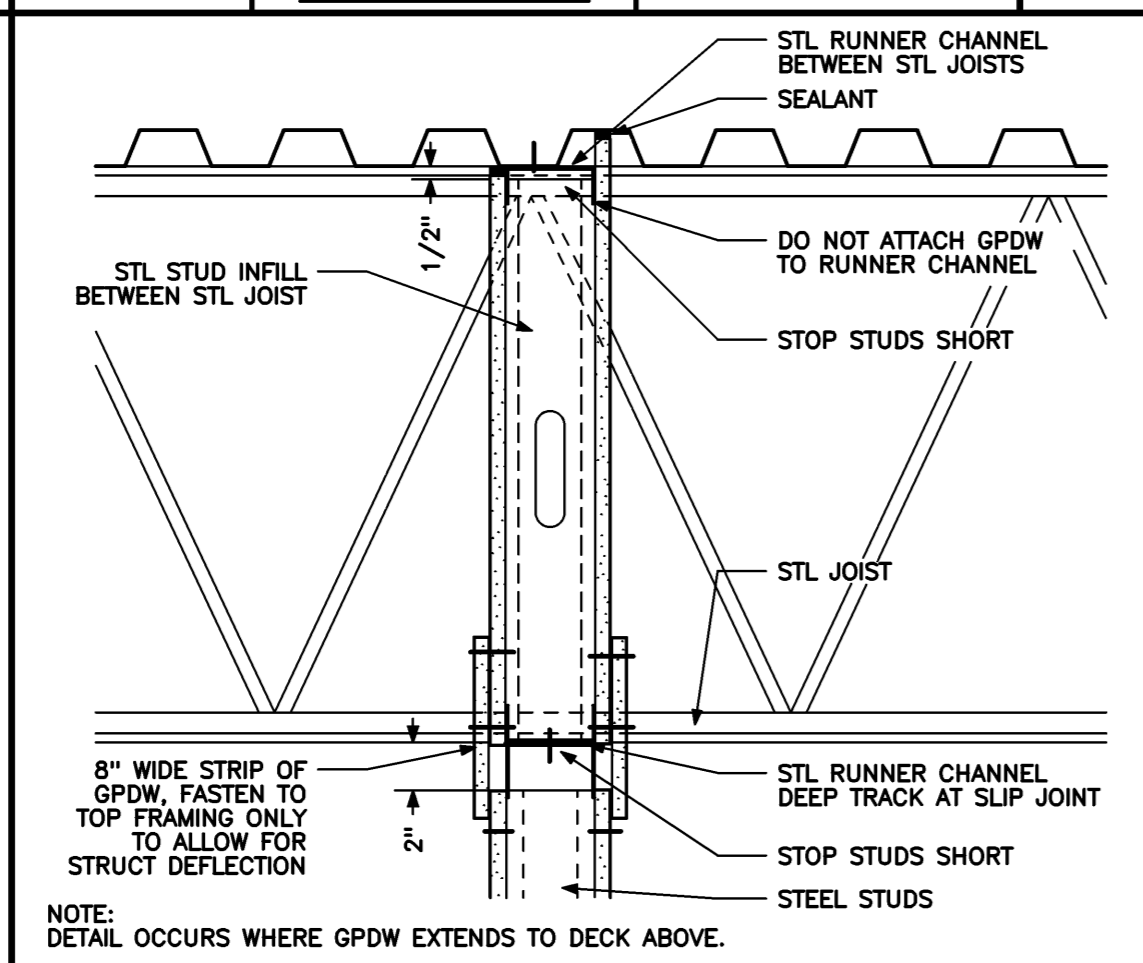

PARTITION PERPENDICULAR TO JOIST

1 1/2" = 1'-0" 0 4' 8' 1' REF: NA

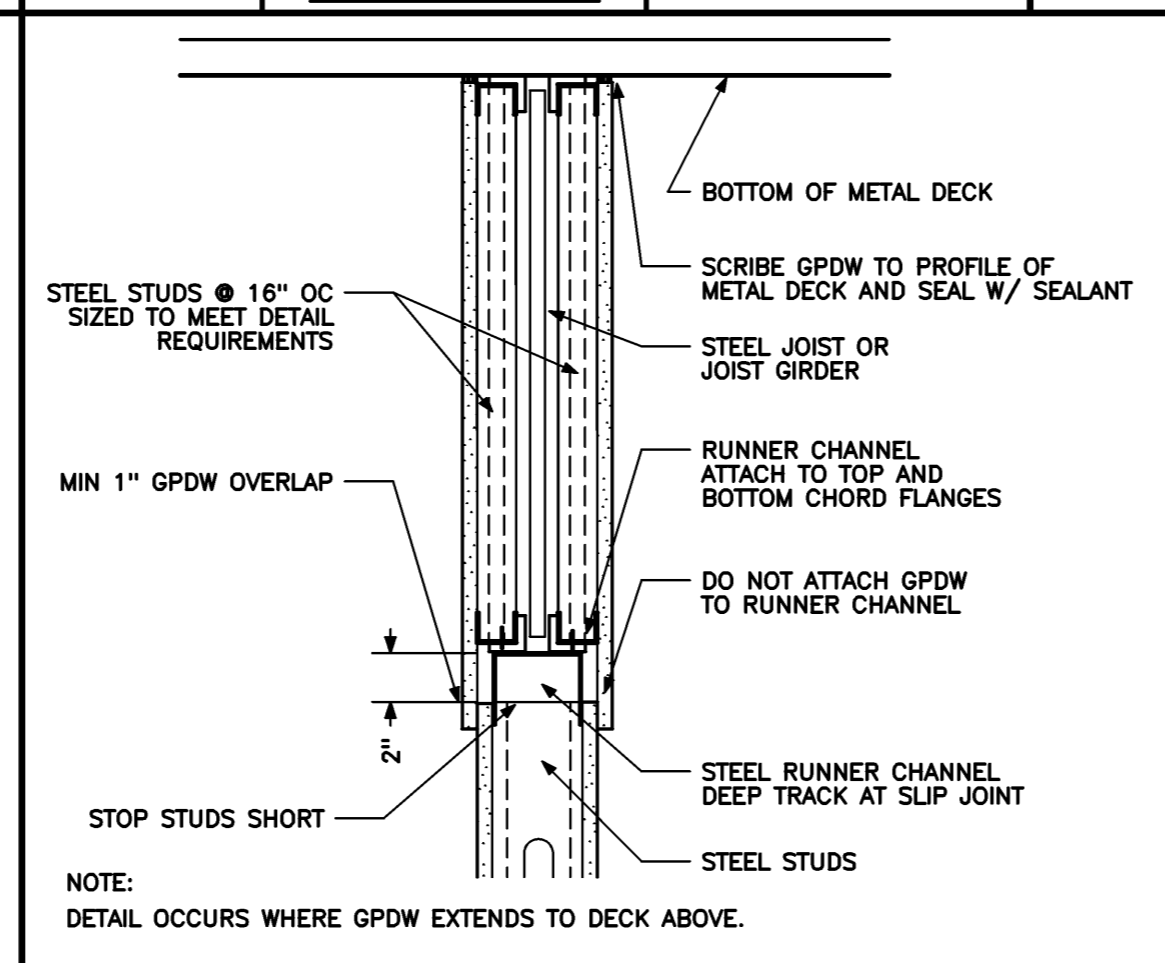

PARTITION TO UNDERSIDE OF JOIST

1 1/2" = 1'-0" 0 4' 8' 1' REF: NA

A4

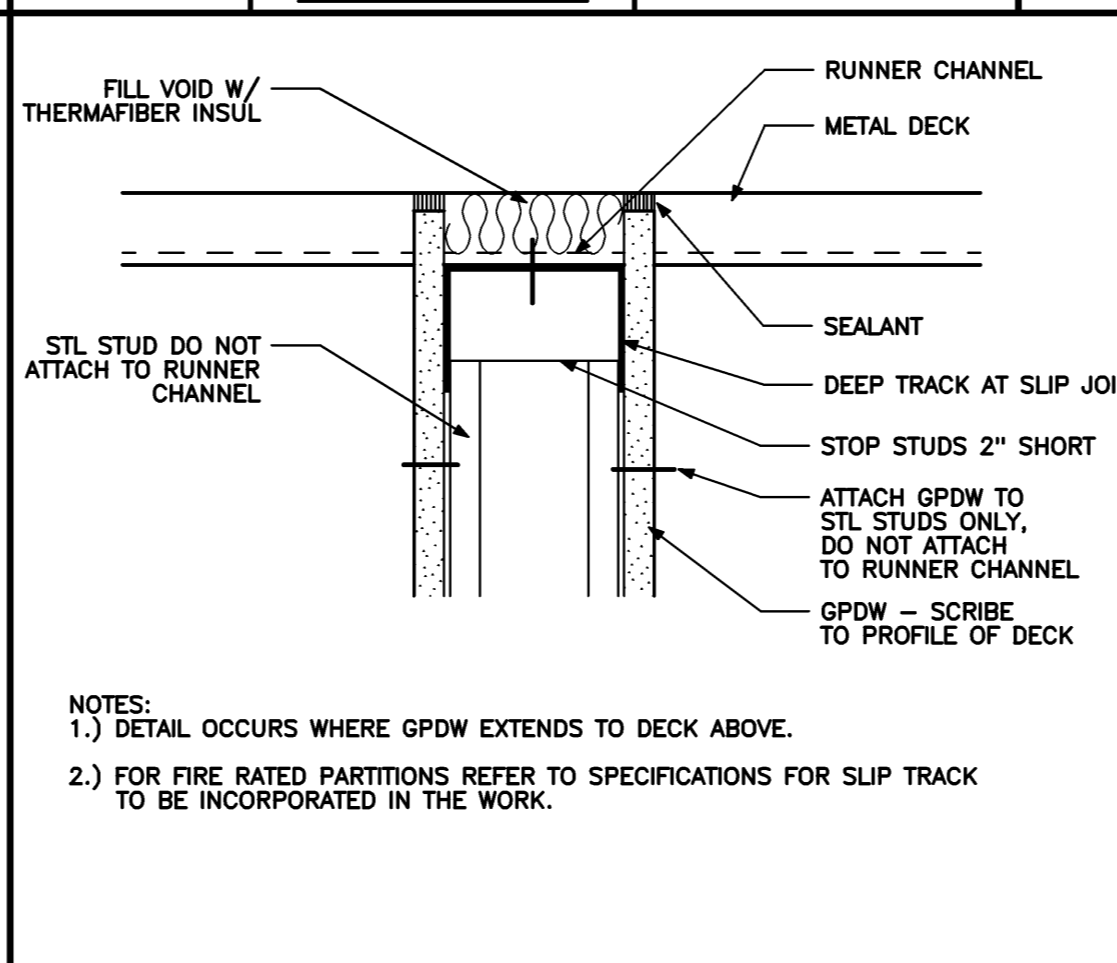

PARTITION PERPENDICULAR TO DECK

3" = 1'-0" 0 2' 4' 8' 1' REF: NA

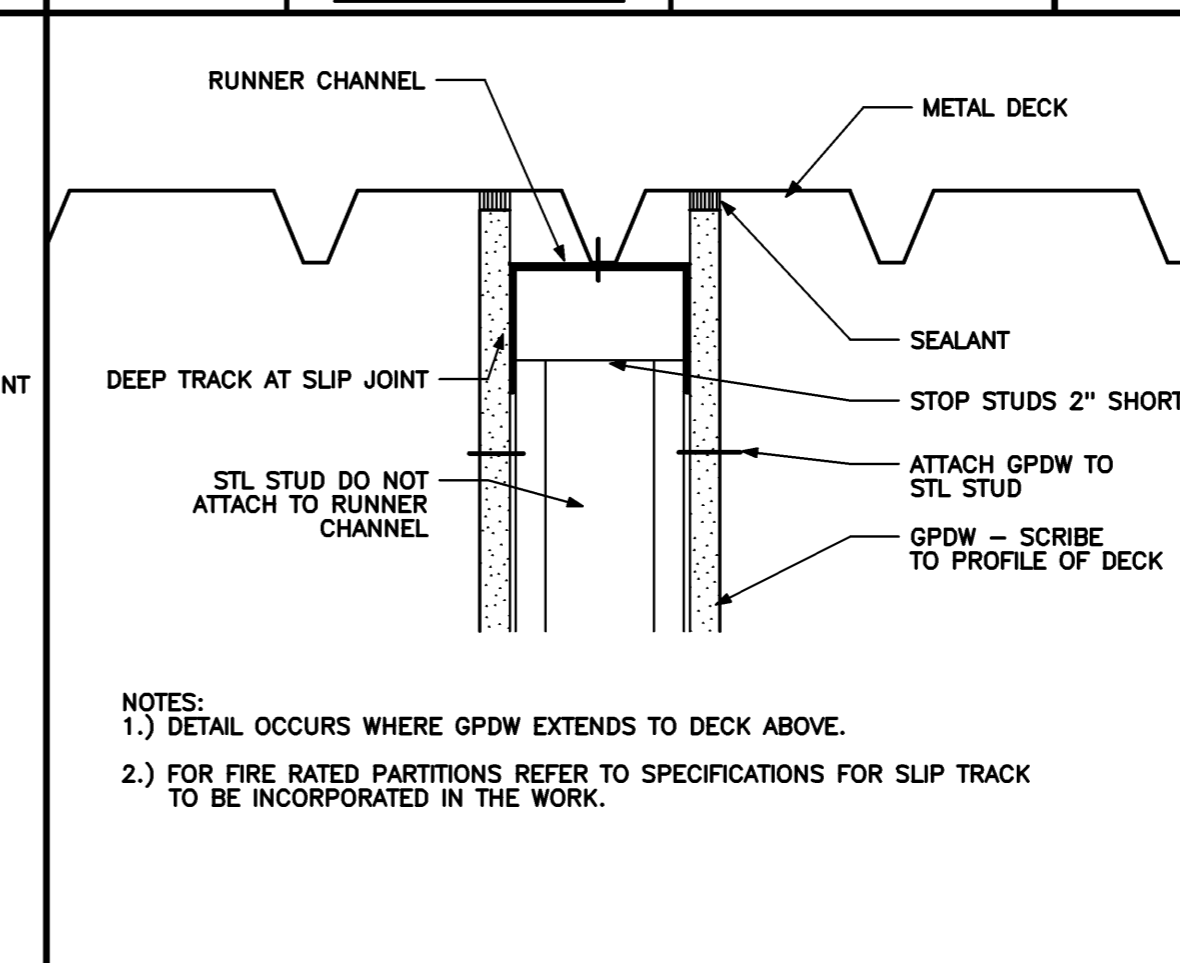

PARTITION PARALLEL TO DECK

3" = 1'-0" 0 2' 4' 8' 1' REF: NA

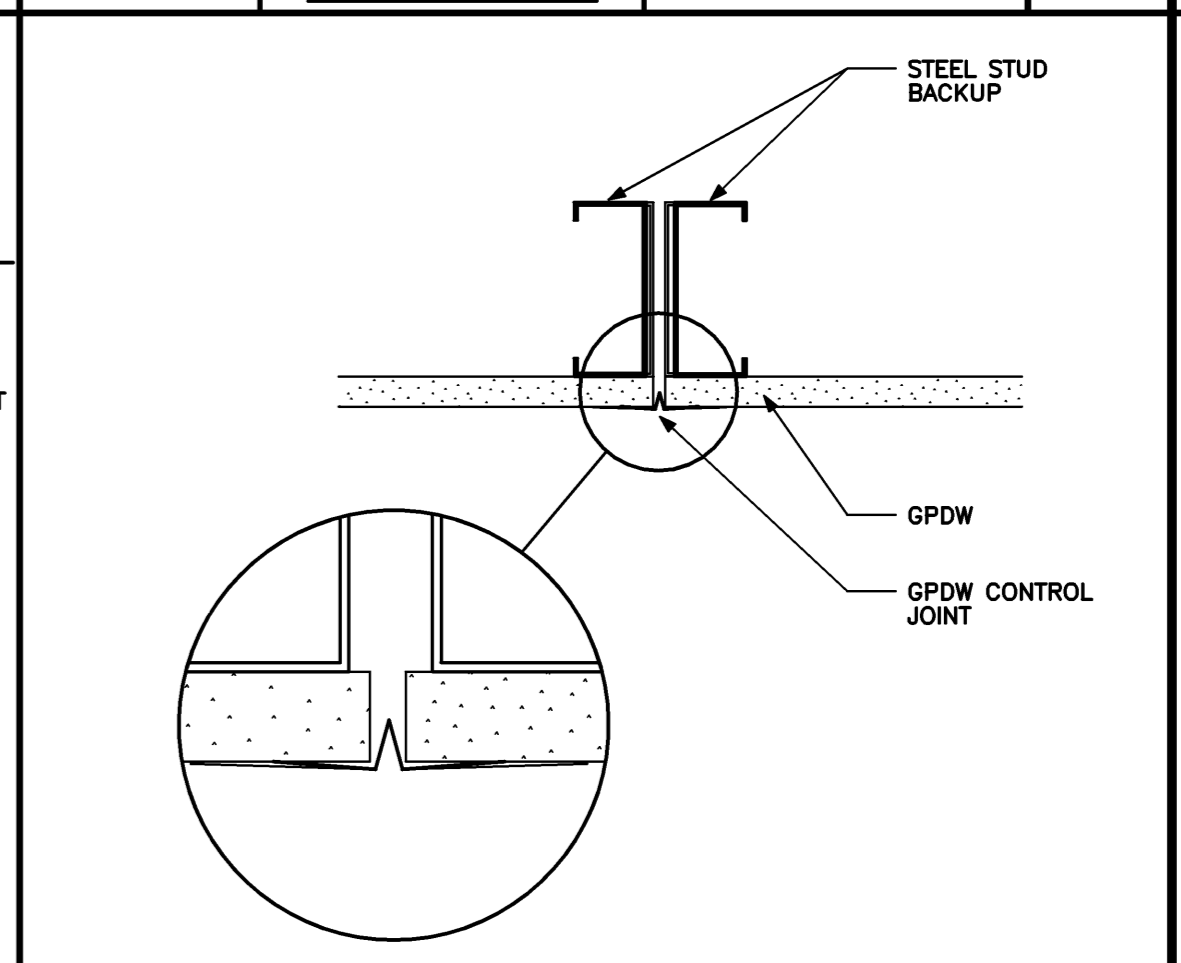

TYPICAL GYP BD CONTROL JOINT DETAIL

3" = 1'-0" 0 2' 4' 8' 1' REF: NA

A1

Drawing Status

Drawing Title

DETAILS & SCHEDULES

PA / PE: **DRE** Drawn By: **DHD**

Drawing Number

A80.1