



HARRIMAN

AUBURN PORTLAND MANCHESTER

JEWISH COMMUNITY ALLIANCE OF SOUTHERN MAINE

PORTLAND, ME

Harriman Project No. 15309

Key Plan

Proj North

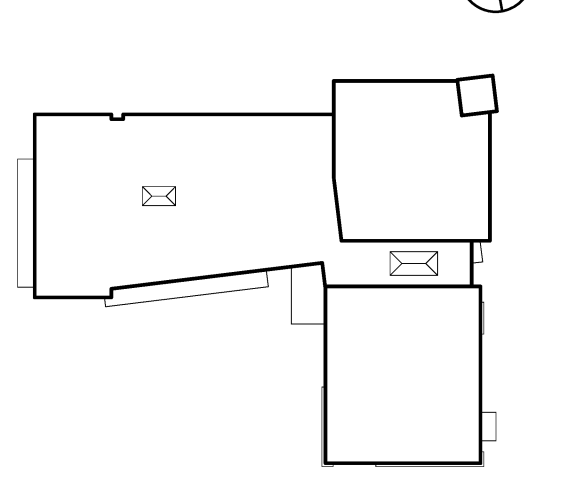

GENERAL NOTES

- DIMENSIONS LOCATING INTERIOR PARTITIONS ARE TO FACE OF GPDW, U.N.O.
- SEE DRAWING A4.1 FOR PARTITION TYPES.
- GC TO PROVIDE SOLID BLOCKING IN STUD WALLS FOR MOUNTING OF ALL OWNER AND GC PROVIDED ACCESSORIES.

LEGEND

- WATER CLOSET
- URINAL
- LAVATORY
- PAPER TOWEL DISPENSER - PTD
- WASTE RECEPTACLE - WR
- SANITARY NAPKIN DISPENSER - SND1
- SANITARY NAPKIN DISPENSER - SND2
- HAND DRYER - HD
- GRAB BARS
- TOILET TISSUE DISPENSER - TTD
- SOAP DISPENSER - SD

Mark	Date	Description
-	09-04-15	DESIGN DEVELOPMENT REVIEW
-	03-25-16	CONSTRUCTION DOCUMENTS
1	04-15-16	ADDENDUM #1
2	04-21-16	ADDENDUM #2
3	07-22-16	CONFORMANCE SET

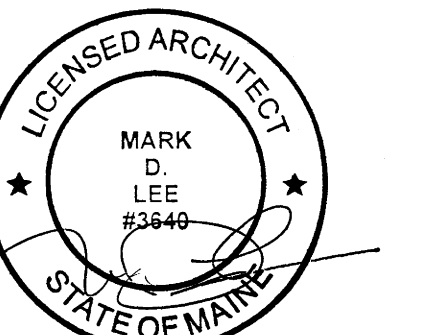

Drawing Scales: As indicated

PA/PE: MDL © 2016 Harriman Associates  
Drawn By: JAE

ENLARGED PLANS

A11.1

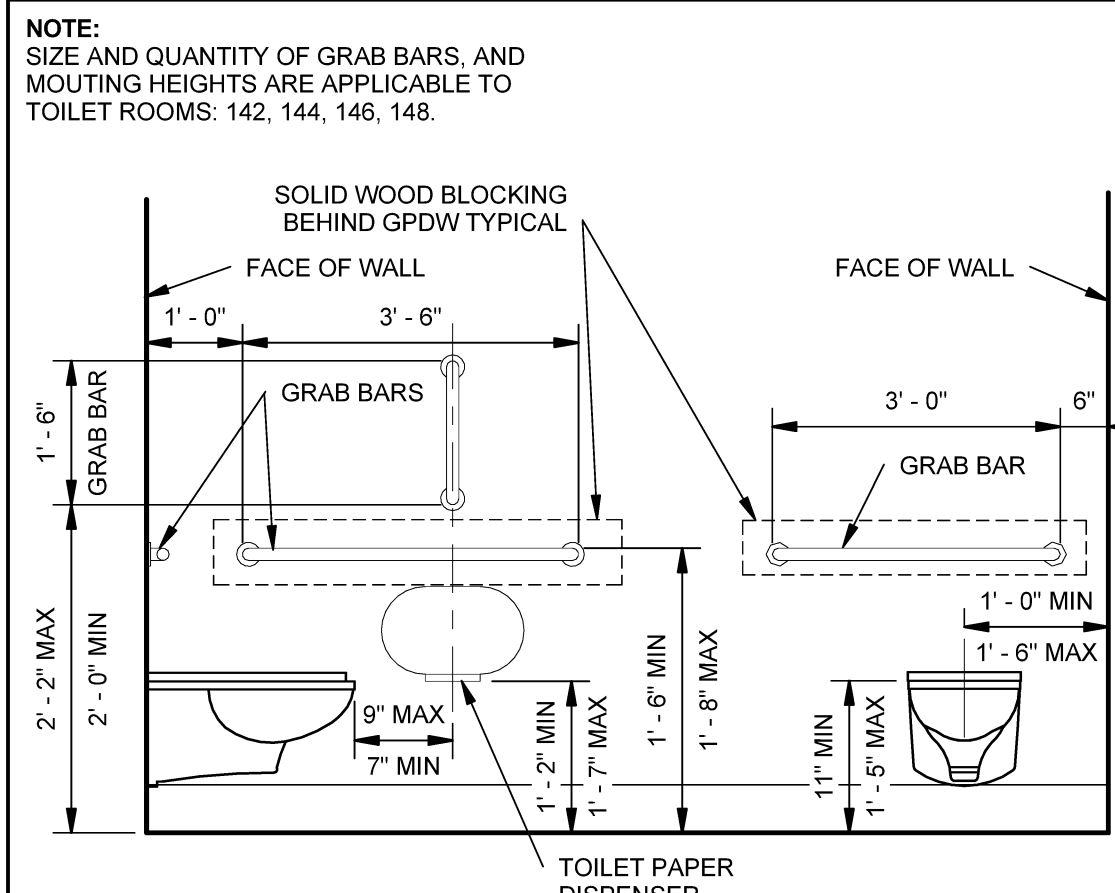

E1 MOUNTING DETAILS AT CHILD RESTROOMS  
SCALE: 1/2" = 1'-0"

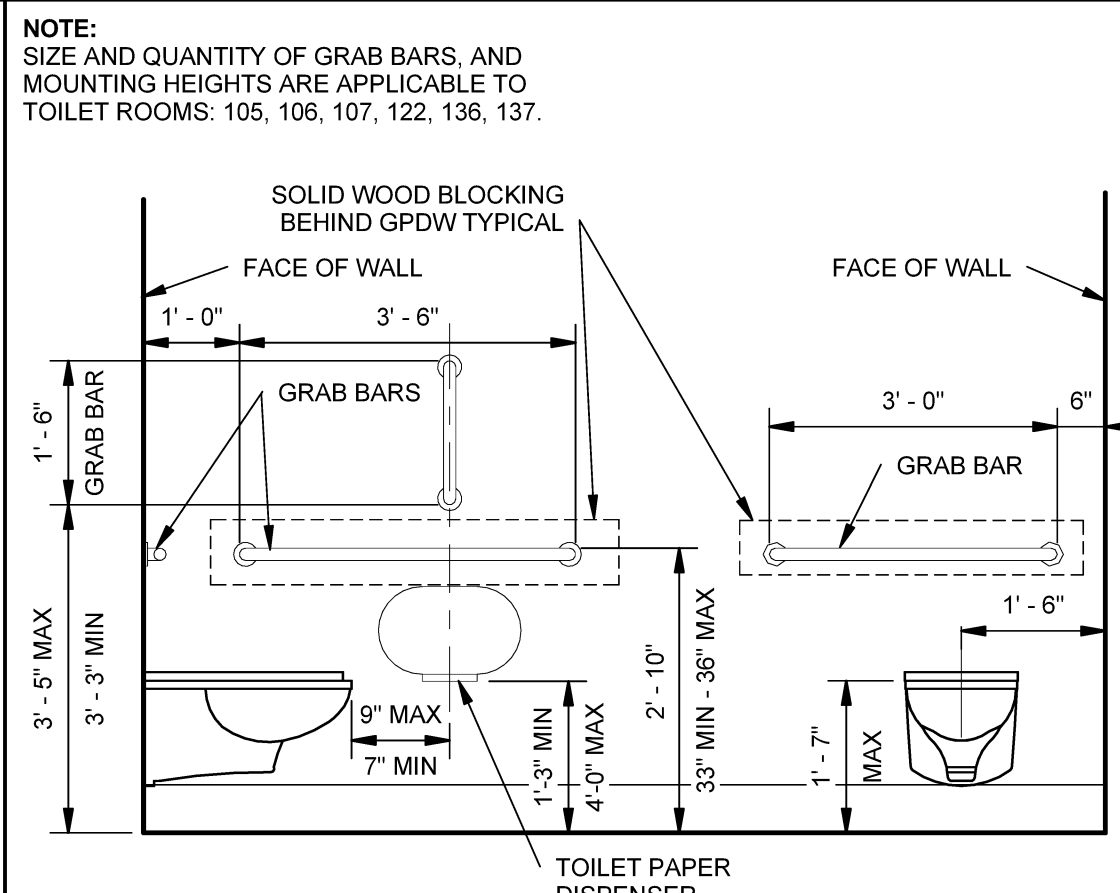

E2 MOUNTING DETAILS  
SCALE: 1/2" = 1'-0"

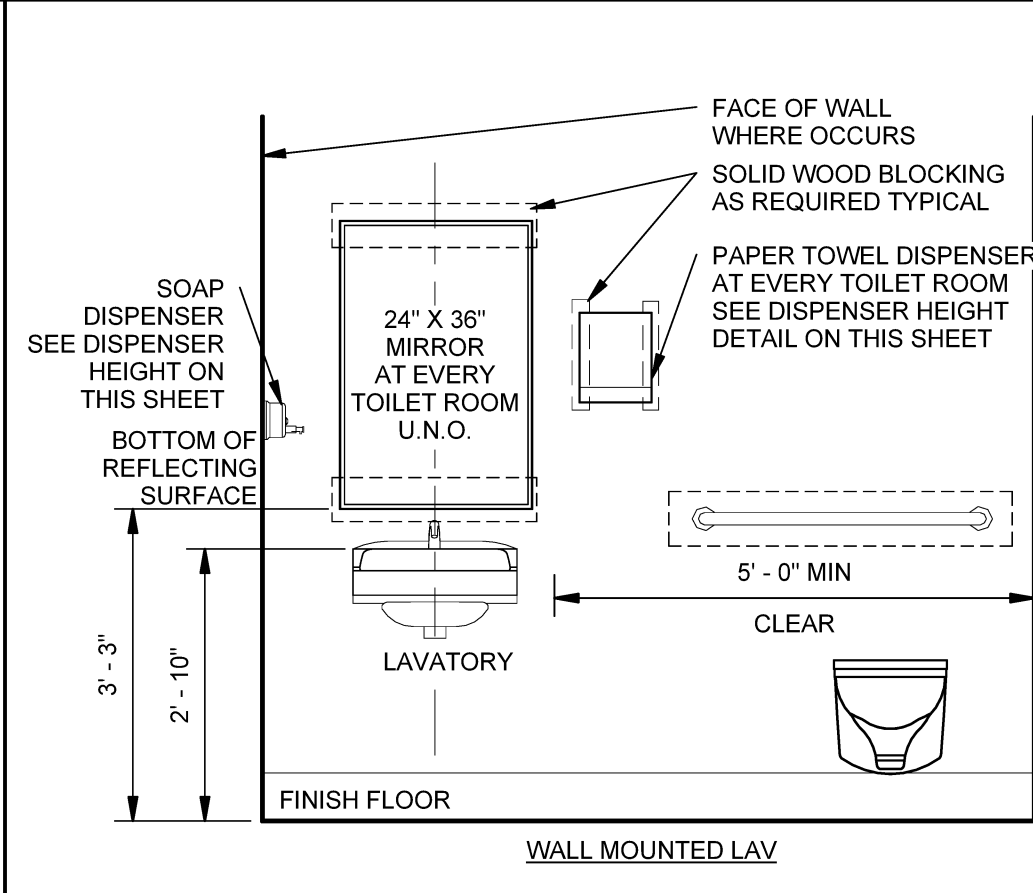

E3 LAVATORY MOUNTING HEIGHTS  
SCALE: 1/2" = 1'-0"

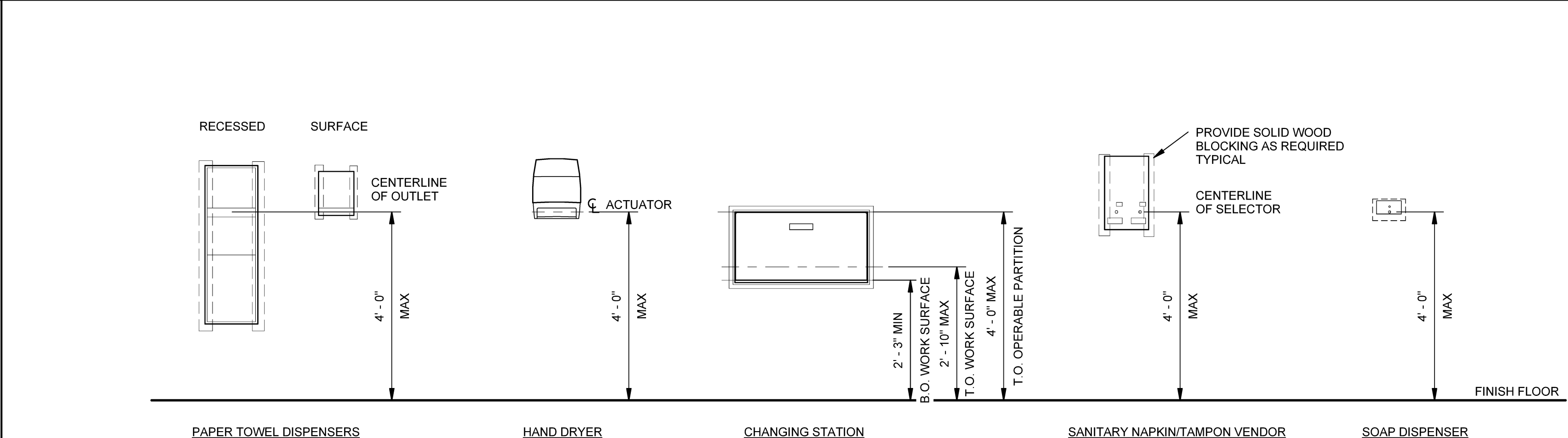

E4 DISPENSER MOUNTING HEIGHTS  
SCALE: 1/2" = 1'-0"

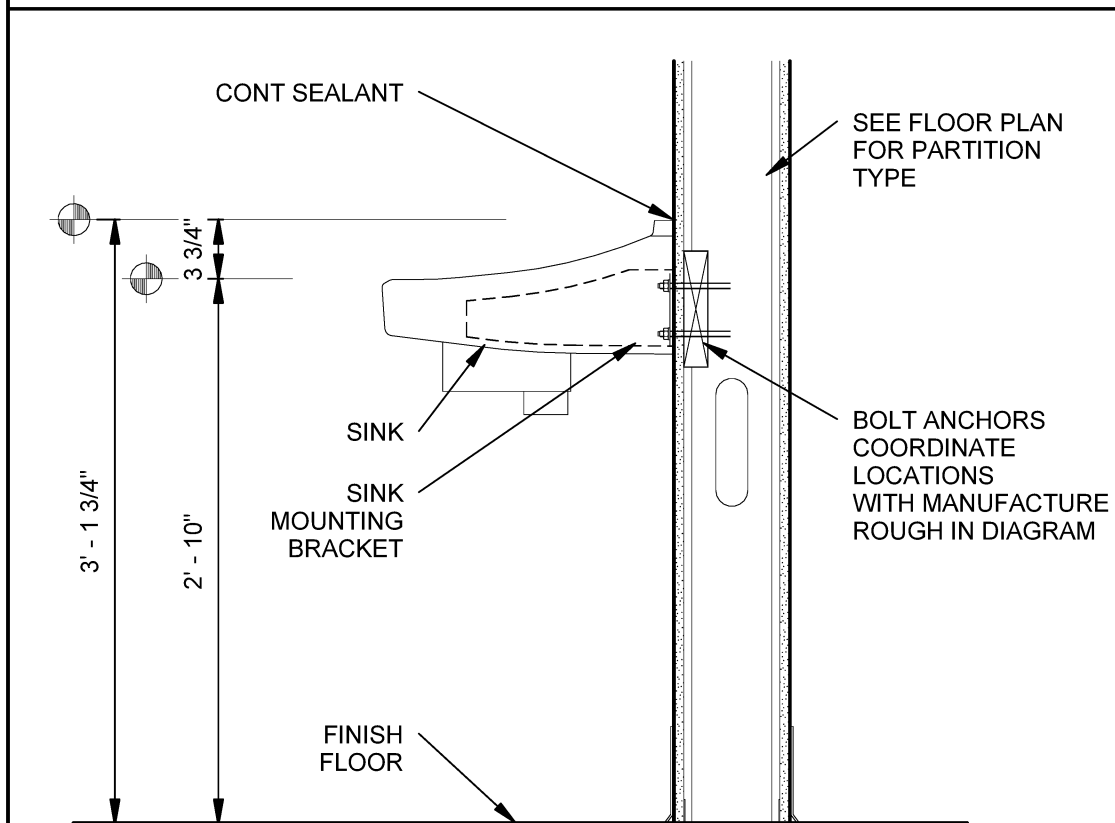

D1 LAVATORY MOUNTING DETAIL  
SCALE: 1" = 1'-0"

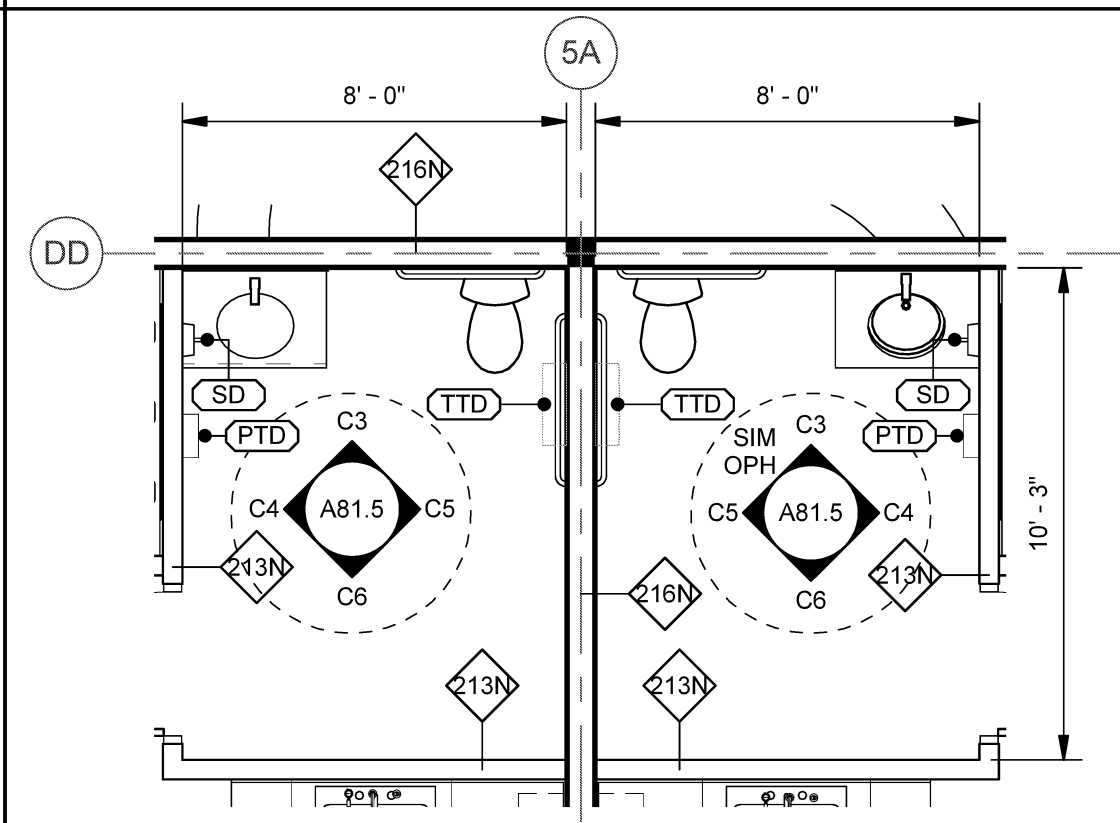

D2 TOILET ROOMS 146 AND 148  
SCALE: 1/4" = 1'-0"

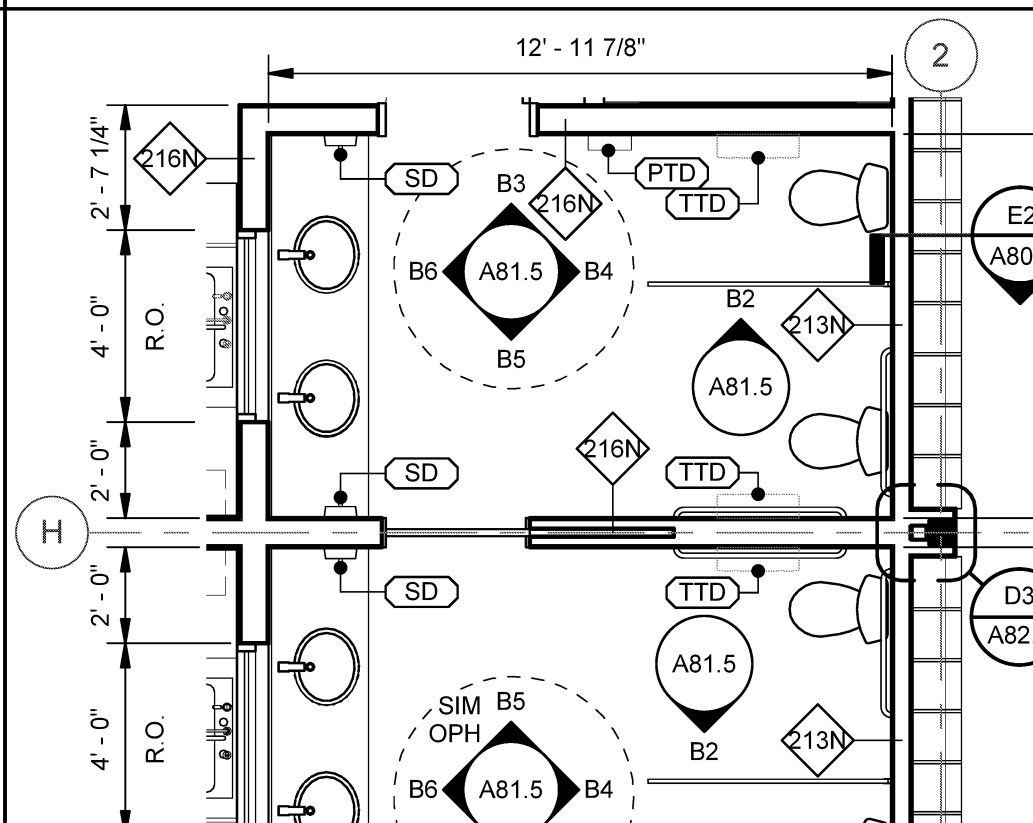

D3 TOILET ROOMS 142 AND 144  
SCALE: 1/4" = 1'-0"

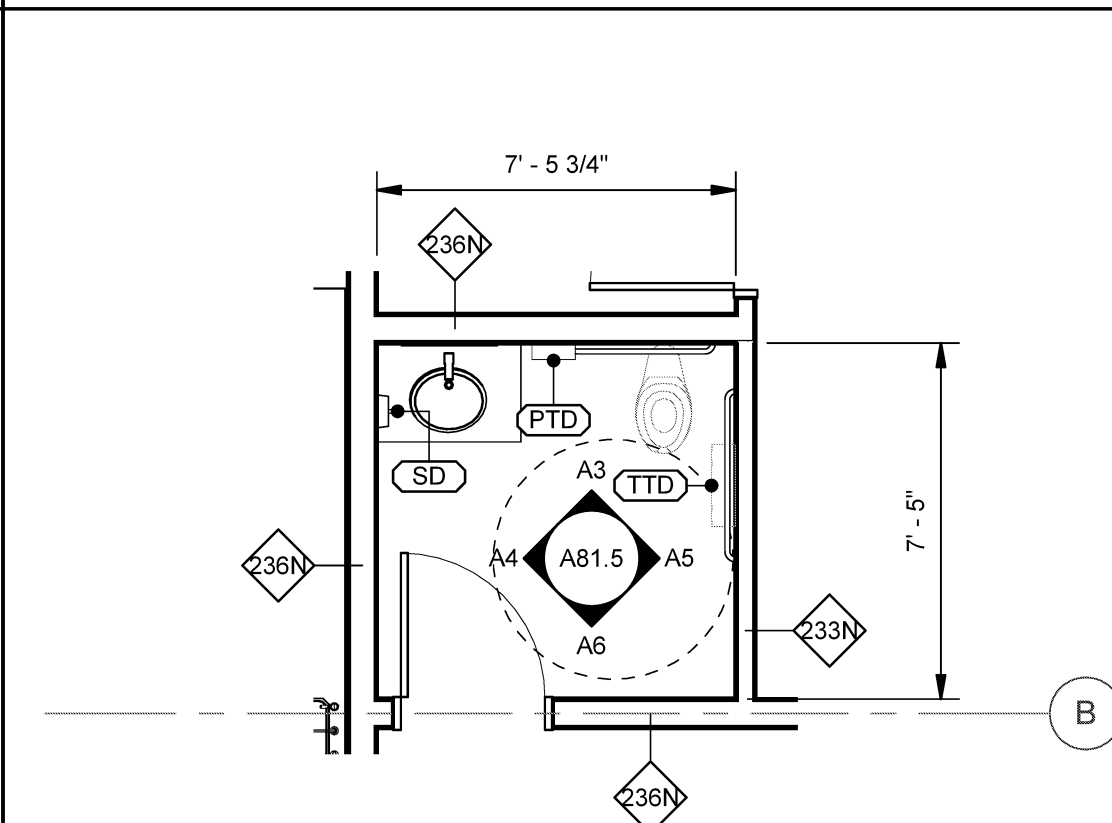

D4 TOILET ROOM 122  
SCALE: 1/4" = 1'-0"

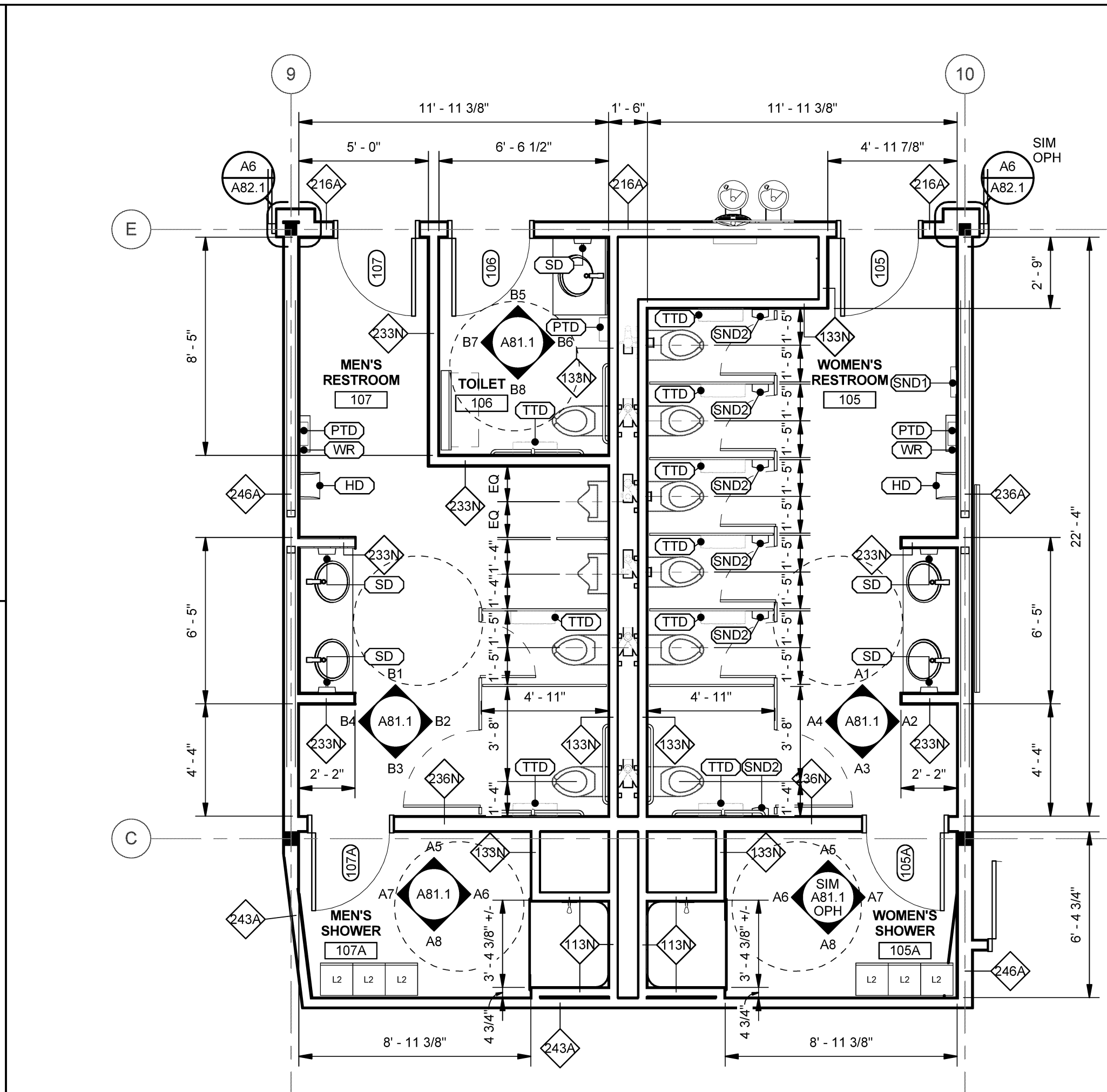

C5 TOILET ROOMS 105 AND 107  
SCALE: 1/4" = 1'-0"

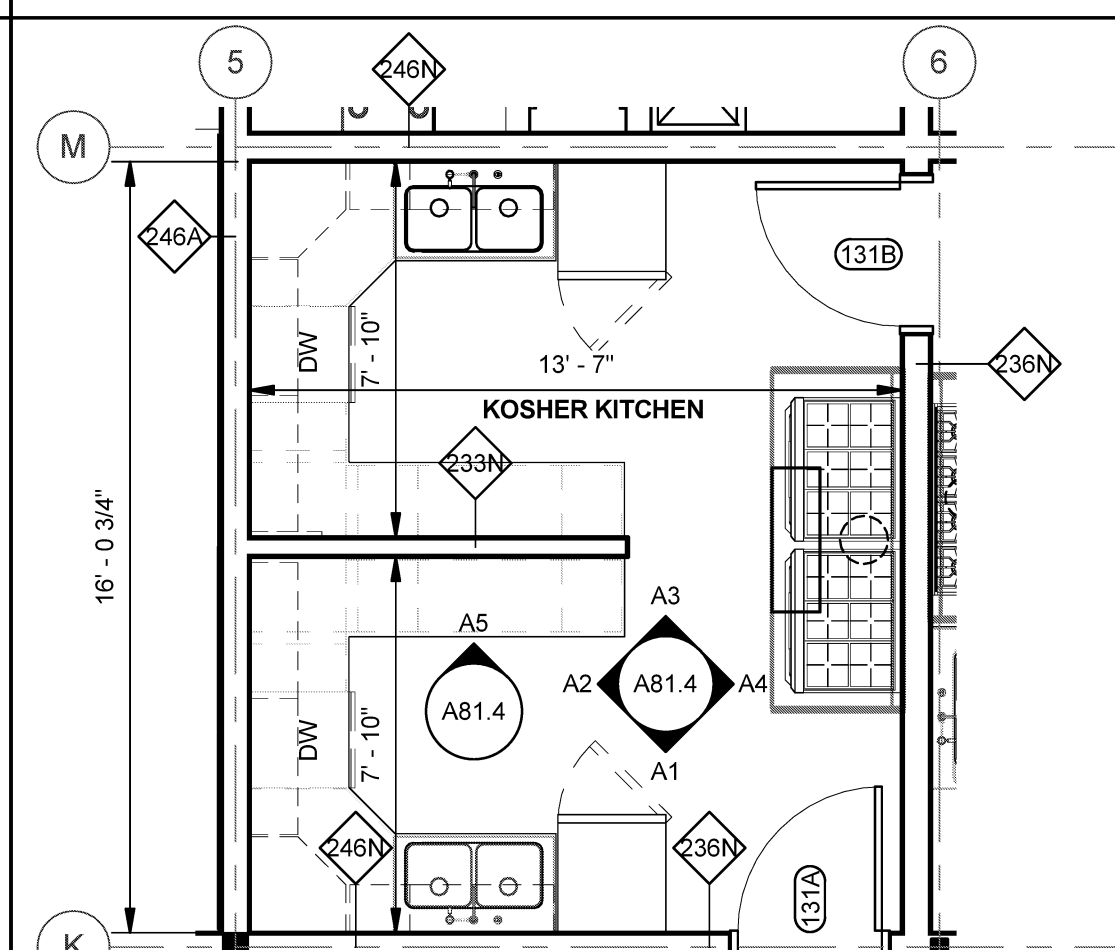

B5 KOSHER KITCHEN ENLARGED PLAN  
SCALE: 1/4" = 1'-0"

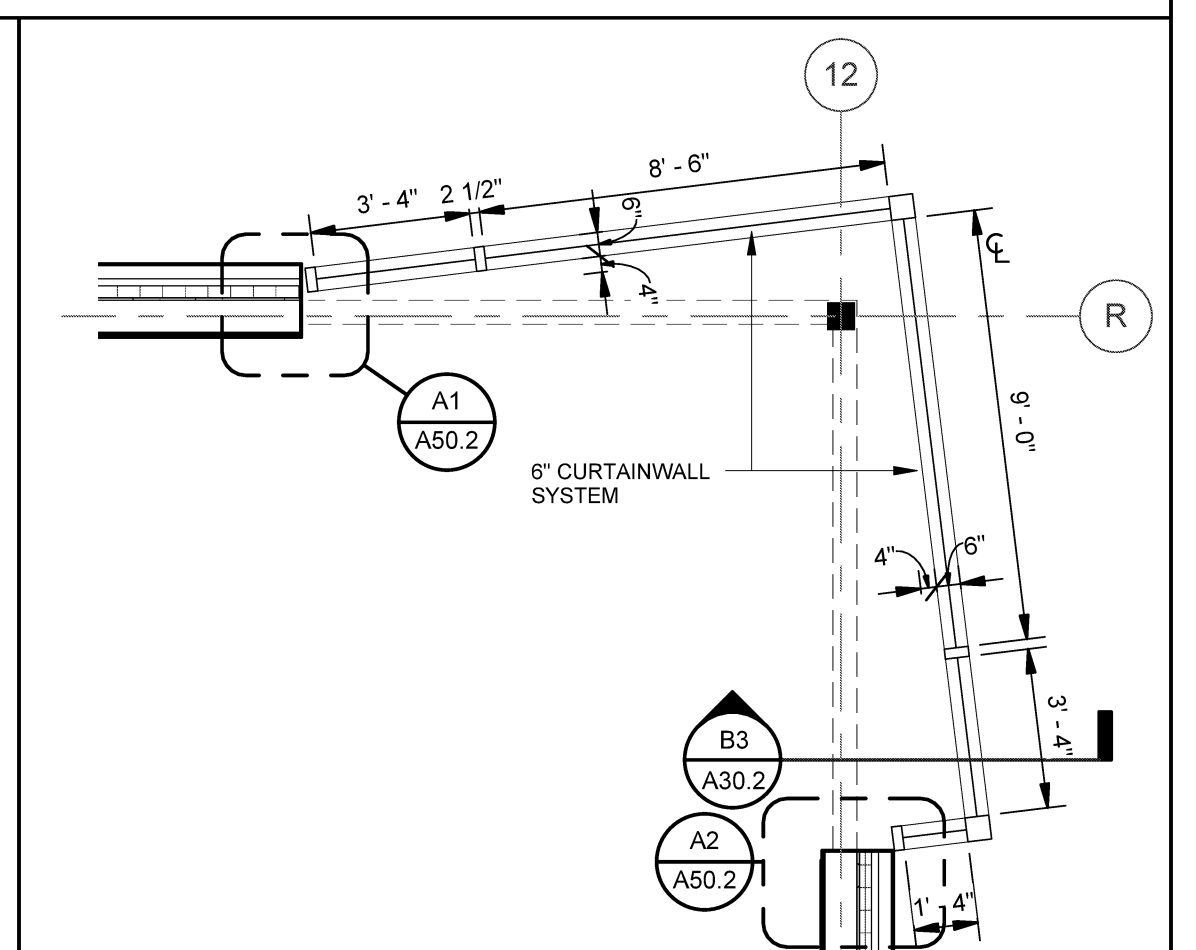

B6 PLAN SECTION AT COLUMN R12  
SCALE: 1/4" = 1'-0"

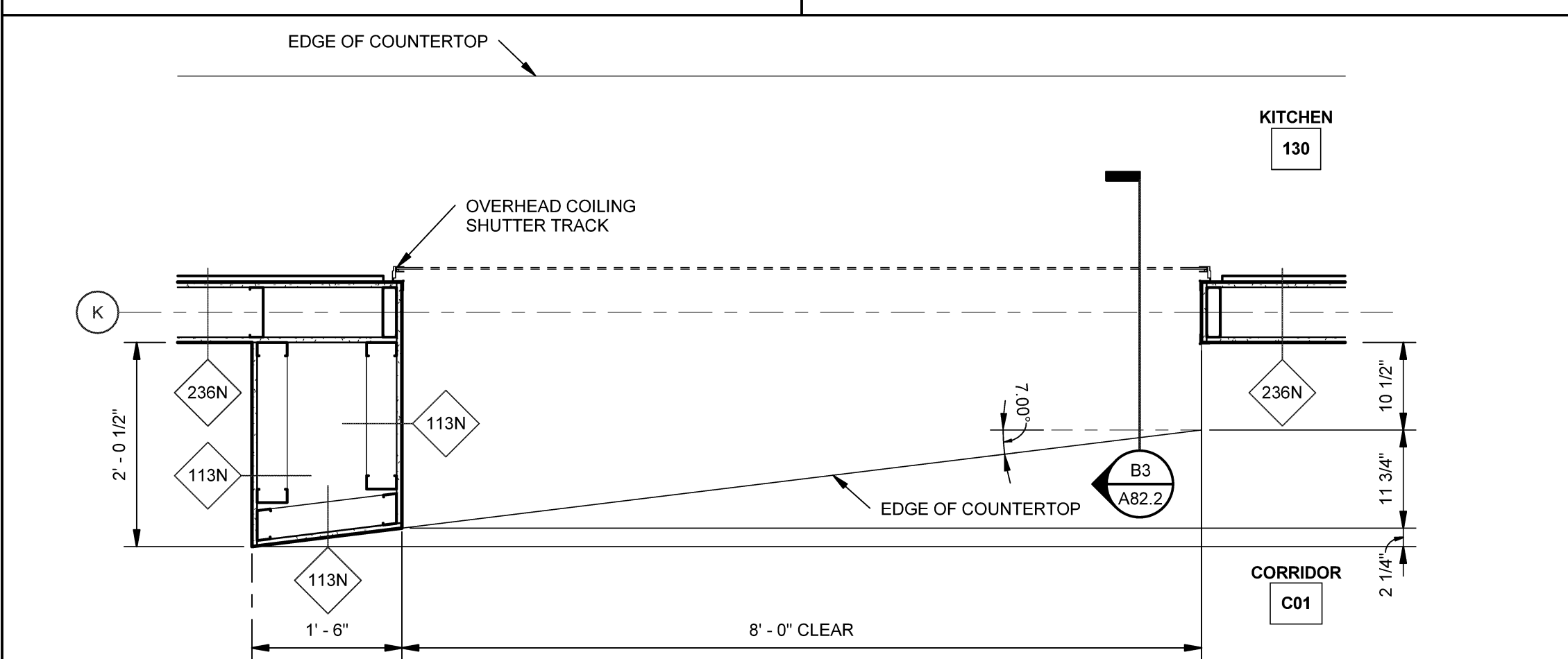

A4 PLAN DETAIL AT SERVING WINDOW  
SCALE: 3/4" = 1'-0"

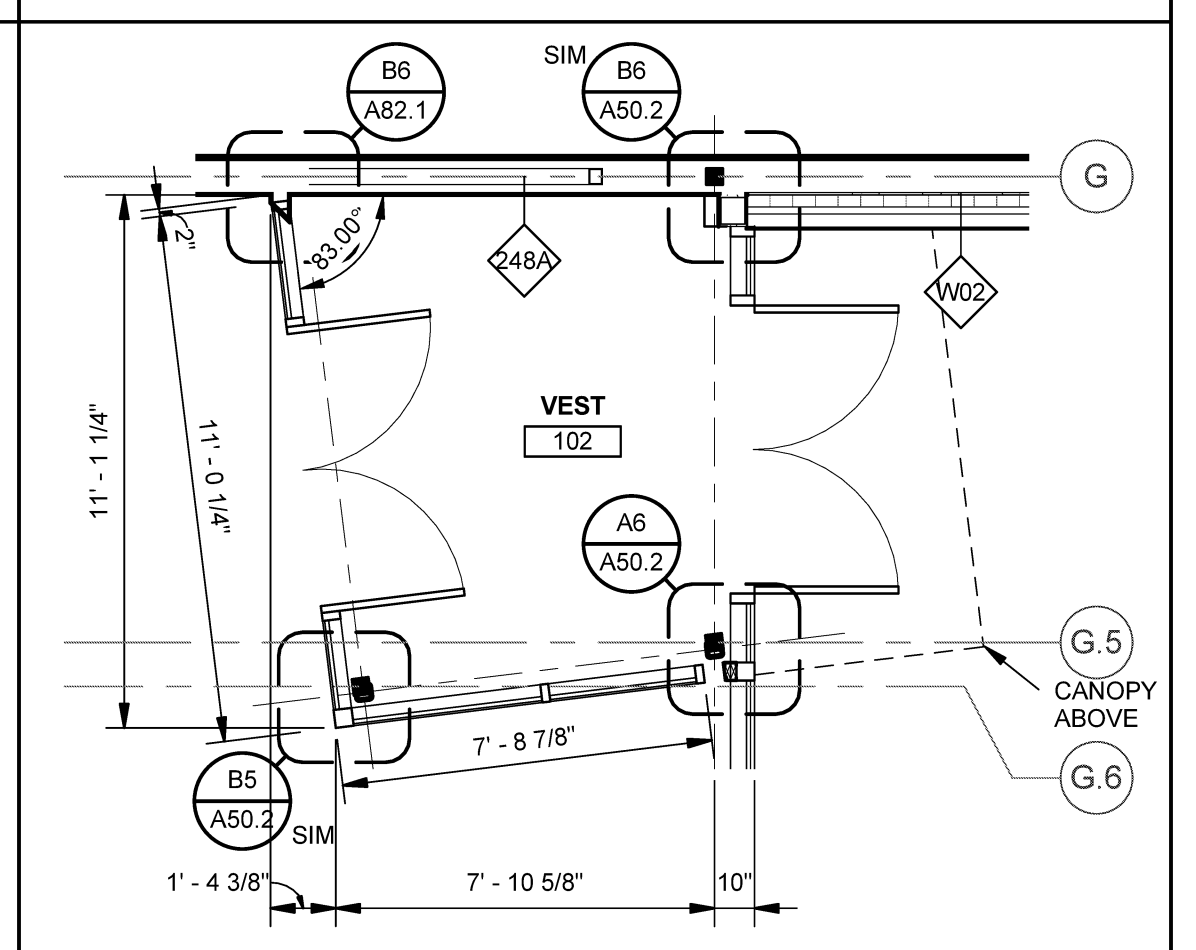

A6 VESTIBULE 102  
SCALE: 1/4" = 1'-0"