

DISPLAY THIS CARD ON PRINCIPAL FRONTAGE OF WORK



CITY OF PORTLAND BUILDING PERMIT



This is to certify that

DRISCOLL KAREN L /Mike McDonald Heating Service
LLC

PERMIT ID: 2013-00224

Located at

23 MITTON ST

CBL: 191 A006001

has permission to **HVAC; Install Carling gas boiler**

provided that the person or persons, firm or corporation accepting this permit shall comply with all of the provisions of the Statues of Maine and of the Ordinances of the City of Portland regulating the construction, maintenance and use of the buildings and structures, and of the application on file in the department.

Notification of inspection and written permission procured before this building or part thereof is lathed or otherwise cloed-in. 48 HOUR NOTICE IS REQUIRED.

A final inspection must be completed by owner before this building or part thereof is occupied. If a certificate of occupancy is required, it must be procured prior to occupancy.

Fire Prevention Officer



Code Enforcement Officer / Plan Reviewer

**THIS CARD MUST BE POSTED ON THE STREET SIDE OF THE PROPERTY
THERE IS A PENALTY FOR REMOVING THIS CARD**

PERMIT ID: 2013-00224

Located at: 23 MITTON ST

CBL: 191 A006001

BUILDING PERMIT INSPECTION PROCEDURES
Please call 874-8703 (ONLY)
or email: buildinginspections@portlandmaine.gov

With the issuance of this permit, the owner, builder or their designee is required to provide adequate notice to the city of Portland Inspections Services for the following inspections. Appointments must be requested 48 to 72 hours in advance of the required inspection. The inspection date will need to be confirmed by this office.

- **Please read the conditions of approval that is attached to this permit!! Contact this office if you have any questions.**
- **Permits expire in 6 months. If the project is not started or ceases for 6 months.**
- **If the inspection requirements are not followed as stated below additional fees may be incurred due to the issuance of a "Stop Work Order" and subsequent release to continue.**

REQUIRED INSPECTIONS:

Close-in Plumbing/Framing
Final Inspection

The project cannot move to the next phase prior to the required inspection and approval to continue, REGARDLESS OF THE NOTICE OF CIRCUMSTANCES.

IF THE PERMIT REQUIRES A CERTIFICATE OF OCCUPANCY, IT MUST BE PAID FOR AND ISSUED TO THE OWNER OR DESIGNEE BEFORE THE SPACE MAY BE OCCUPIED.

City of Portland, Maine - Building or Use Permit

389 Congress Street, 04101 Tel: (207) 874-8703, Fax: (207) 874-8716

Permit No: 2013-00224	Date Applied For: 02/04/2013	CBL: 191 A006001
---------------------------------	--	----------------------------

Location of Construction: 23 MITTON ST	Owner Name: DRISCOLL KAREN L	Owner Address: 23 MITTON ST	Phone:
Business Name:	Contractor Name: Mike McDonald Heating Service LL	Contractor Address: 160 Fellow Street Portland	Phone (207) 318-7079
Lessee/Buyer's Name	Phone:	Permit Type: HVAC	

Proposed Use: Same: Single Family	Proposed Project Description: HVAC; Install Carling gas boiler
---	--

Dept: Zoning **Status:** Approved **Reviewer:** Marge Schmuckal **Approval Date:** 02/04/2013
Note: **Ok to Issue:**

Dept: Building **Status:** Approved w/Conditions **Reviewer:** Jon Rioux **Approval Date:** 02/11/2013
Note: **Ok to Issue:**

1) The installation must comply with UL, the Manufacturers' Listing, MUBEC (IRC, 2009), and State of Maine Gas Regulations.

Separate permits are required for any electrical: plumbing, sprinkler, fire alarm, HVAC systems, commercial hood exhaust systems and fuel tanks. Separate plans may need to be submitted for approval as a part of this process.

Maintain proper setback(s) from property lines/buildings and proper clearances from vertical openings when direct venting

A Carbon Monoxide (CO) alarm shall be installed in each area within or giving access to bedrooms. That detection must be powered by the electrical service (plug-in or hardwired) in the building and battery.

M1804.2.5 Direct vent terminations. Vent terminals for direct-vent appliances shall be installed in accordance with the manufacturer's installation instructions.

City of Portland, Maine - Building or Use Permit Application

389 Congress Street, 04101 Tel: (207) 874-8703, Fax: (207) 874-8716

Permit No: 2013-00224	Issue Date:	CBL: 191 A006001
---------------------------------	--------------------	----------------------------

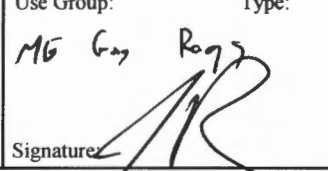
Location of Construction: 23 MITTON ST	Owner Name: DRISCOLL KAREN L	Owner Address: 23 MITTON ST PORTLAND, ME 04102		Phone:
Business Name:	Contractor Name: McDonald, Mike Heating Service LLC	Contractor Address: 160 Fellow Street South Portland ME 04106		Phone (207) 318-7079
Lessee/Buyer's Name	Phone:	Permit Type: HVAC		Zone: R5
Past Use: Single Family	Proposed Use: Single Family	Permit Fee: \$50.00	Cost of Work: \$3,000.00	CEO District: 6
		FIRE DEPT: <input type="checkbox"/> Approved <input type="checkbox"/> Denied <input type="checkbox"/> N/A		INSPECTION: HVAC Use Group: Type: MG Guy Rogers 
Proposed Project Description: HVAC; Install Carling gas boiler		Signature: _____ PEDESTRIAN ACTIVITIES DISTRICT (P.A.D.): Action: <input type="checkbox"/> Approved <input type="checkbox"/> Approved w/Conditions <input type="checkbox"/> Denied Signature: _____ Date: _____		

Permit Taken By: bjs	Date Applied For: 02/04/2013	Zoning Approval		
--------------------------------	--	------------------------	--	--

1. This permit application does not preclude the Applicant(s) from meeting applicable State and Federal Rules. 2. Building permits do not include plumbing, septic or electrical work. 3. Building permits are void if work is not started within six (6) months of the date of issuance. False information may invalidate a building permit and stop all work..	Special Zone or Reviews <input type="checkbox"/> Shoreland <input type="checkbox"/> Wetland <input type="checkbox"/> Flood Zone <input type="checkbox"/> Subdivision <input type="checkbox"/> Site Plan Maj <input type="checkbox"/> Minor <input type="checkbox"/> MM <input type="checkbox"/> Date: <u>2/4/13</u>	Zoning Appeal <input type="checkbox"/> Variance <input type="checkbox"/> Miscellaneous <input type="checkbox"/> Conditional Use <input type="checkbox"/> Interpretation <input type="checkbox"/> Approved <input type="checkbox"/> Denied Date: _____	Historic Preservation <input checked="" type="checkbox"/> Not in District or Landmark <input type="checkbox"/> Does Not Require Review <input type="checkbox"/> Requires Review <input type="checkbox"/> Approved <input type="checkbox"/> Approved w/Conditions <input type="checkbox"/> Denied Date: 
--	---	---	--

CERTIFICATION

I hereby certify that I am the owner of record of the named property, or that the proposed work is authorized by the owner of record and that I have been authorized by the owner to make this application as his authorized agent and I agree to conform to all applicable laws of this jurisdiction. In addition, if a permit for work described in the application is issued, I certify that the code official's authorized representative shall have the authority to enter all areas covered by such permit at any reasonable hour to enforce the provision of the code(s) applicable to such permit.

SIGNATURE OF APPLICANT	ADDRESS	DATE	PHONE
RESPONSIBLE PERSON IN CHARGE OF WORK, TITLE		DATE	PHONE

From: <mikemcdonaldheating@maine.rr.com>
To: Jonathan Rioux <JRIOUX@portlandmaine.gov>
Date: 2/11/2013 4:54 PM
Subject: Re: 23 Mitton St

Yes it is a single flue and it is listed and Paul Pickett is installing it.
Thanks Mike

---- Jonathan Rioux <JRIOUX@portlandmaine.gov> wrote:

> Mike,

>

> Is the "Metal" Chimney being installed at 23 Mitton St Listed, and a single flue?

>

>

>

>

>

>

>

>

> Jonathan Rioux

> Code Enforcement Officer/ Plan Reviewer

>

> City of Portland

> Planning and Urban Development Department

> Inspection Services Division

> 389 Congress St. Rm 315

> Portland, ME 04101

> Office: 207.874.8702

> Support Staff: 207.874.8703

> jrioux@portlandmaine.gov

>

> Notice: Under Maine law, documents - including e-mails - in the possession of public officials or city employees about government business may be classified as public records. There are very few exceptions. As a result, please be advised that what is written in an e-mail could be released to the public and/or the media if requested.

>

>

>



FILL IN AND SIGN WITH INK

APPLICATION FOR PERMIT HEATING OR POWER EQUIPMENT

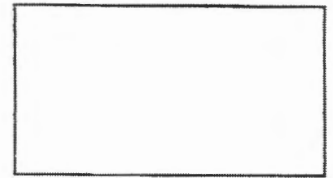

To the INSPECTOR OF BUILDINGS, PORTLAND, ME.

The undersigned hereby applies for a permit to install the following heating, cooking or power equipment in accordance with the Laws of Maine, the Building Code of the City of Portland, and the following specifications:

Location / CBL 23 Mitton St Portland Use of Building Home Owner Date 2/4/13
Name and address of owner of appliance Karen Driscoll 23 Mitton St Portland

Installer's name and address Mike McDonald Heating Service LLC
160 Fellows St So. Portland, Me. 04106 Telephone 318-7079

Location of appliance:

- Basement
- Attic
- Floor
- Roof

Type of Fuel:

- Gas
- Oil
- Solid

Appliance Name:

Carling

U.L. Approved Yes No

Will appliance be installed in accordance with the manufacture's installation instructions? Yes No

IF NO Explain: _____

The Type of License of Installer:

- Master Plumber # _____
- Solid Fuel # _____
- Oil # _____
- Gas # PNT 5249
- Other _____

Type of Chimney:

- Masonry Lined
Factory built _____

Metal Paul Pickett
Factory Built U.L. Listing # _____
Chimney liner

- Direct Vent
Type _____ UL# _____

Type of Fuel Tank

- Oil
- Gas

Size of Tank _____

Number of Tanks _____

Distance from Tank to Center of Flame _____ feet.

Cost of Work: \$ 3050.00

Permit Fee: \$ 50

Approved

Approved with Conditions

Fire: _____

Ele.: _____

Bldg.: _____

- See attached letter or requirement

Signature of Installer

Mike McDonald

Inspector's Signature

Date Approved

White - Inspection Yellow - File Pink - Applicant's Gold - Assessor's Copy



MODEL **EZ-Gas** Gas burner

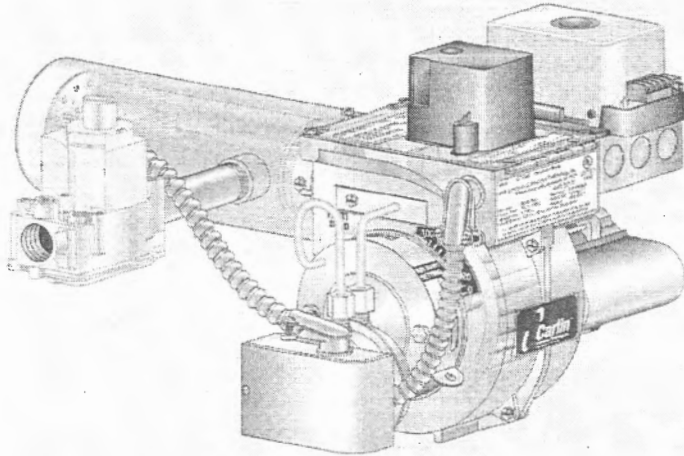

User's information

Contents

Operating instructions	2
PLEASE read carefully	3
Care and maintenance	3

WARNING: If the information in this manual is not followed exactly, a fire or explosion may result, causing property damage, personal injury or death.

- Do not store or use gasoline or other flammable vapors and liquids in the vicinity of this or any other appliance.
- **WHAT TO DO IF YOU SMELL GAS**
 - Do not try to light any appliance.
 - Do not touch any electrical switch; do not use any phone in your building.
 - Immediately call your gas supplier from an outside phone. Follow the gas supplier's instructions.
 - If you cannot reach your gas supplier, call the fire department.
- Installation and service must be performed by a qualified installer, service agency or the gas supplier.

WARNING Provide unobstructed combustion air openings sized and located per appliance manual and applicable codes.

Retain this *User's information* manual for your use. Read this manual completely. Ask your service technician if you have any questions regarding the use of the burner or appliance.

Retain the *Burner manual* only for use by your qualified service technician.

Should you observe unusual or abnormal operation of the burner or appliance, contact your qualified service technician immediately. Do not attempt to service or repair this product yourself.

© Copyright 2002 — Carlin Combustion Technology, Inc.

Carlin Combustion Technology, Inc.
70 Maple Street
Ph 413-525-7700

East Longmeadow, MA 01028
Fx 413-525-8306

carlincombustion.com

From: Tammy Munson
To: support staff
Date: 2/4/2013 9:29 AM
Subject: Fwd: Karen Driscoll Heating Permit.
Attachments: 23 Mitton st.jpg; Carlin EZ Gas burner info. - Copy.jpg; Carlin Manual.jpg

>>> <mikemcdonaldheating@maine.rr.com> 2/4/2013 9:15 AM >>>

Portland Permit People, Here is a permit for 23 Mitton Street, for Karen Driscoll. Attached you will find all the info you will need to process this permit. Please Call 828-1608 for credit card payment for the permit. Thank you. Stacy McDonald