

2.

1.

REV'S:

CODE:

TOWN: PORTLAND

DATE: 10-10-2017

SCALE: AS NOTED

DESIGNED: SSA

DRAWN: SSA

TITLE:

BUILDING SECTIONS

FILE:

SHEET: A4

DRAFTSMEN:

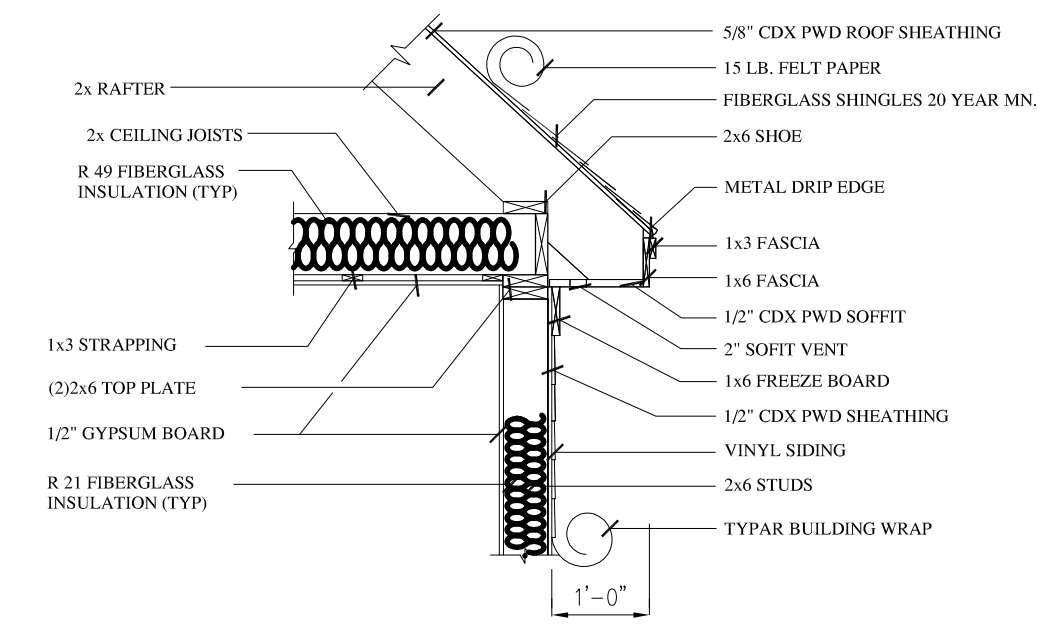

SOFFIT DETAIL

SCALE: 1/2"=1'-0"
NOTE: SUBSTITUTE JOIST AND RAFTER SIZES WITH PLAN CALL-OUT.

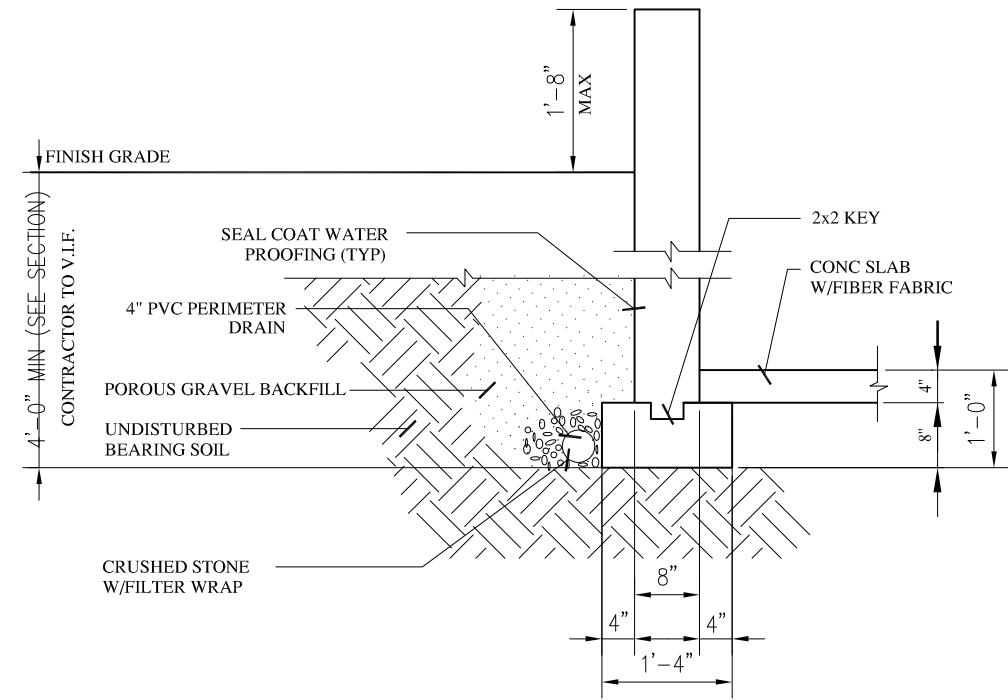

FOOTING DETAIL

SCALE: 1/2"=1'-0"
NOTE: SUBSTITUTE FOOTING AND WALL SIZES WITH PLAN CALL-OUT.

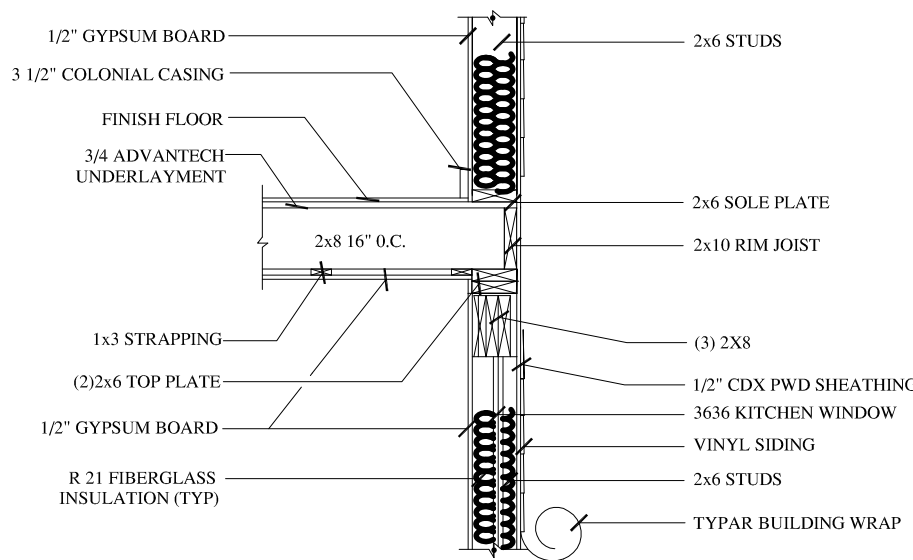

EXTERIOR WALL DETAIL

SCALE: 1/2"=1'-0"
NOTE: SUBSTITUTE JOIST AND RAFTER SIZES WITH PLAN CALL-OUT.

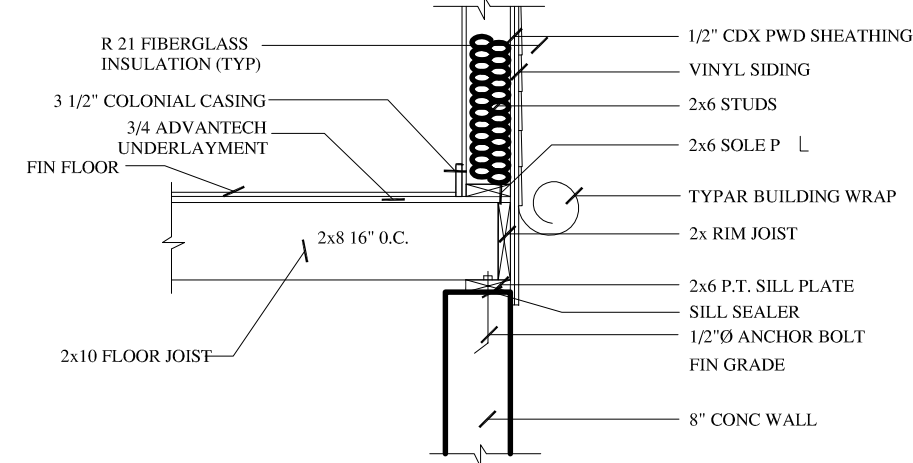

WALL BASE DETAIL

SCALE: 1/2"=1'-0"
NOTE: SUBSTITUTE JOIST AND RAFTER SIZES WITH PLAN CALL-OUT.

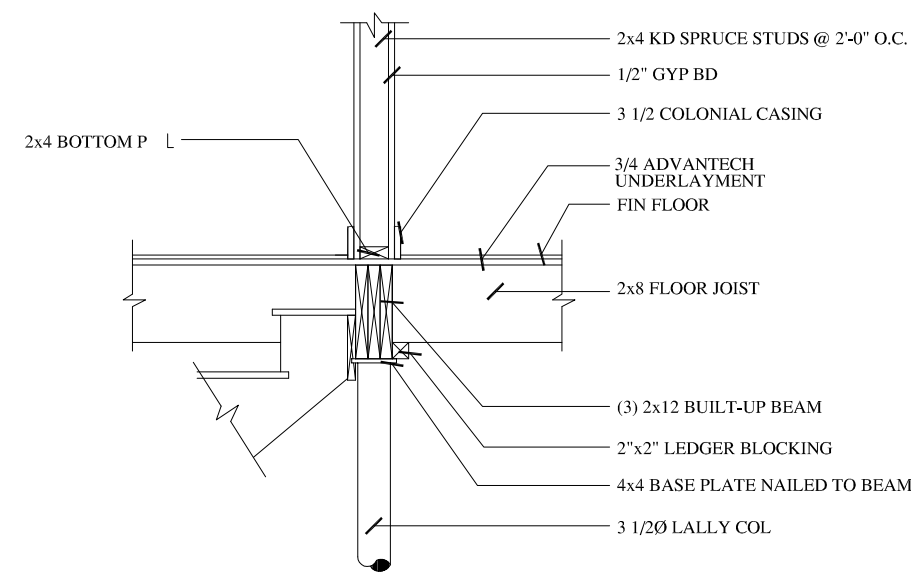

COLUMN/GIRDER DETAIL

SCALE: 1/2"=1'-0"
NOTE: SUBSTITUTE JOIST AND RAFTER SIZES WITH PLAN CALL-OUT.

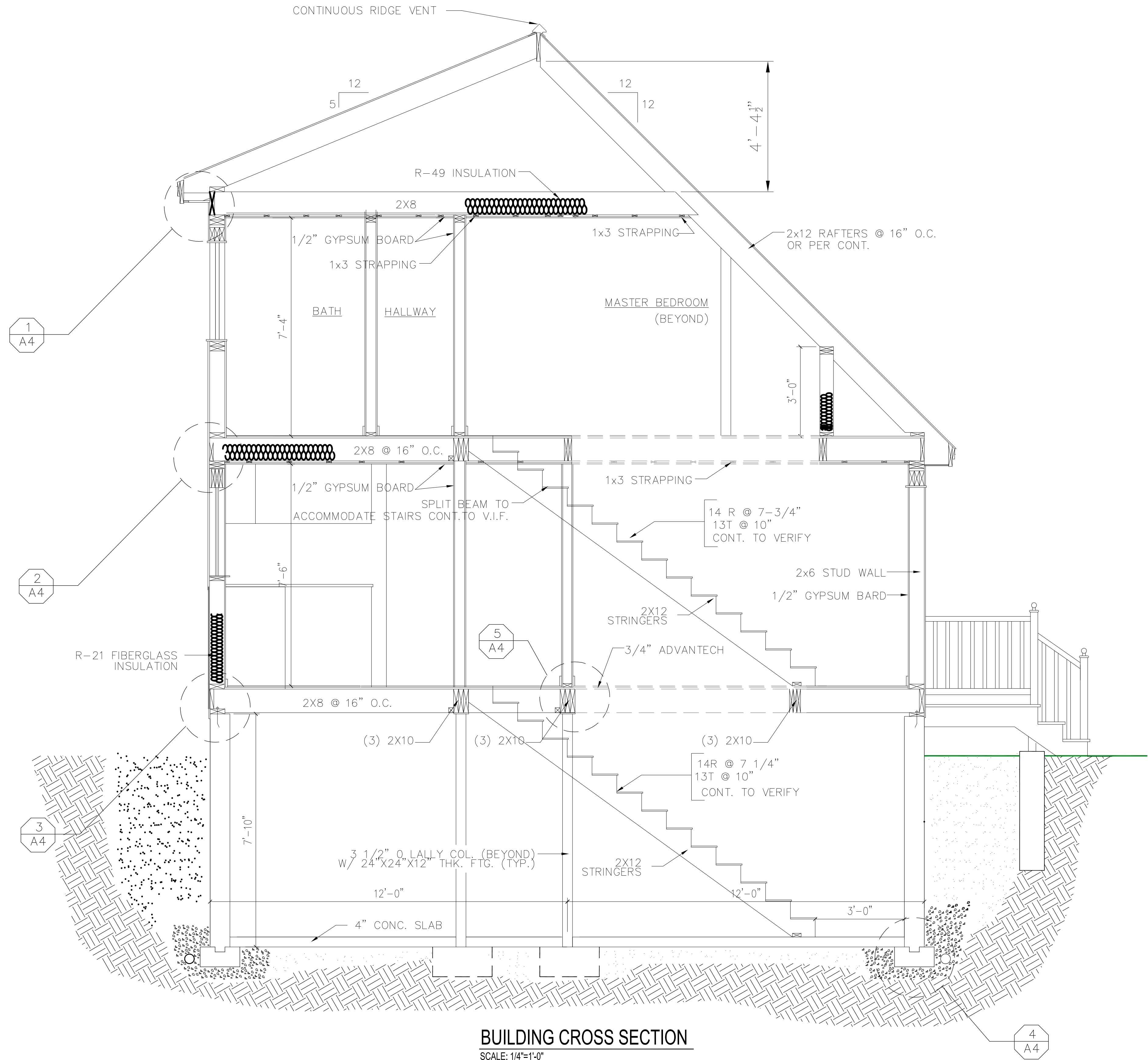

BUILDING CROSS SECTION

SCALE: 1/4"=1'-0"