

Form # P 04

# DISPLAY THIS CARD ON PRINCIPAL FRONTAGE OF WORK CITY OF PORTLAND

Please Read Application And Notes, if Any, Attached

## BUILDING INSPECTION PERMIT

Permit Number: 041352  
**PERMIT ISSUED**  
DEC 27 2004  
CITY OF PORTLAND

This is to certify that Langdon Street Real Estate - Portland Pump Co.

has permission to Install 12000 gallon Diesel Storage Tank

AT 91 Sewall St

190 F008001

provided that the person or persons who apply for and accept this permit shall comply with all of the provisions of the Statutes of Maine and of the Ordinances of the City of Portland regulating the construction, maintenance and use of buildings and structures, and of the application on file in this department.

Apply to Public Works for street line and grade if nature of work requires such information.

Notification of inspection must be given and when permission is procured before this building or part thereof is occupied or otherwise closed-in. 4 HOUR NOISE REQUIREMENT.

A certificate of occupancy must be procured by owner before this building or part thereof is occupied.

### OTHER REQUIRED APPROVALS

Fire Dept. [Signature]

Health Dept. \_\_\_\_\_

Appeal Board \_\_\_\_\_

Other \_\_\_\_\_ Department Name

Director - Building & Inspection Services

**PENALTY FOR REMOVING THIS CARD**

Permit No: 04-1852		Issue Date: DEC 21 2004	CBL: 190 F008001	
Owner Name: Langdon Street Real Estate Inc	Owner Address: 7 Langdon St	Phone:		
Contractor Name: Portland Pump Co.	Contractor Address: P.O. Box 1180 Mussey Rd. Ex. 340 CITY OF PORTLAND	Phone: 503 834317		
Phone:	Permit Type: Tanks - Commercial	Zone: B-5		
Proposed Use:	Permit Fee:	Cost of Work:	CEO District:	
Past Use: Commercial Trailways	Concord trailways / Install 12000 gallon Diesel Storage Tank	FIRE DEPT: <input checked="" type="checkbox"/> Approved <input type="checkbox"/> Denied	INSPECTION: Use Group: U Type: NA ACC TANK APP/04	
Proposed Project Description: Install 12000 gallon Diesel Storage Tank		Signature: <i>[Signature]</i>	Signature: <i>[Signature]</i>	
		Action: <input type="checkbox"/> Approved <input type="checkbox"/> Approved w/Conditions <input type="checkbox"/> Denied	Date:	
Permit Taken By: Idobson	Date Applied For: 12/20/2004	<b>Zoning Approval</b>		
		<b>Special Zone or Reviews</b> <input type="checkbox"/> Shoreland <input type="checkbox"/> Wetland <input type="checkbox"/> Flood Zone <input type="checkbox"/> Subdivision <input type="checkbox"/> Site Plan Maj <input type="checkbox"/> Minor <input type="checkbox"/> MM <input type="checkbox"/> Date: <i>OK 12/21/04</i>	<b>Zoning Appeal</b> <input type="checkbox"/> Variance <input type="checkbox"/> Miscellaneous <input type="checkbox"/> Conditional Use <input type="checkbox"/> Interpretation <input type="checkbox"/> Approved <input type="checkbox"/> Denied Date:	<b>Historic Preservation</b> <input checked="" type="checkbox"/> Not in District or Landmark <input type="checkbox"/> Does Not Require Review <input type="checkbox"/> Requires Review <input type="checkbox"/> Approved <input type="checkbox"/> Approved w/Conditions <input type="checkbox"/> Denied <i>[Signature]</i> Date:

### CERTIFICATION

I hereby certify that I am the owner of record of the named property, or that the proposed work is authorized by the owner of record and that I have been authorized by the owner to make this application as his authorized agent and I agree to conform to all applicable laws of this jurisdiction. In addition, if a permit for work described in the application is issued, I certify that the code official's authorized representative shall have the authority to enter all areas covered by such permit at any reasonable hour to enforce the provision of the code(s) applicable to such permit.

\_\_\_\_\_  
SIGNATURE OF APPLICANT

\_\_\_\_\_  
ADDRESS

\_\_\_\_\_  
DATE

\_\_\_\_\_  
PHONE

\_\_\_\_\_  
RESPONSIBLE PERSON IN CHARGE OF WORK, TITLE

\_\_\_\_\_  
DATE

\_\_\_\_\_  
PHONE

# All Purpose Building Permit Application

If you or the property owner owes real estate or personal property taxes or user charges on any property within the City, payment arrangements must be made before permits of any kind are accepted.

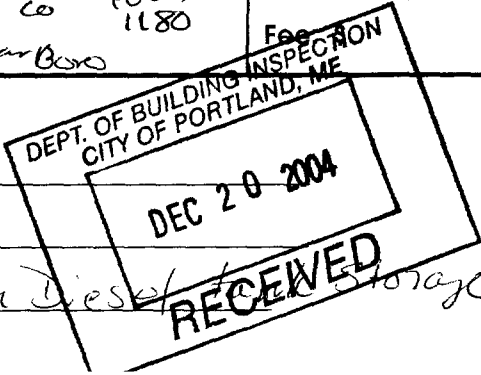
Location/Address of Construction: <u>Portland Transportation Center Thompson's Point Connector Rd</u>		
Total Square Footage of Proposed Structure <u>1000</u>	Square Footage of Lot	
Tax Assessor's Chart, Block & Lot Chart# <u>0</u> Block# <u>F</u> Lot# <u>8</u>	Owner: <u>Portland Transportation Center</u>	Telephone:
Lessee/Buyer's Name (If Applicable)	Applicant name, address & telephone: <u>Portland Pump Co Po Box 1180 9 Border Rd Scarborough</u>	Cost Of Work: \$ <u>60000</u> Fee: <u>5000</u>
Current use: <u>Concord Trailways</u>		
If the location is currently vacant, what was prior use:		
Approximately how long has it been vacant:		
Proposed use: <u>Install 12000 Gallon Diesel Storage</u>	Project description:	
Contractor's name, address & telephone: <u>Portland Pump</u>		
Who should we contact when the permit is ready: <u>David Croxford 8834317</u>		
Mailing address: <u>Po Box 1180 Scarborough Me 04070</u>		
We will contact you by phone when the permit is ready. You must come in and pick up the permit and review the requirements before starting any work, with a Plan Reviewer. A stop work order will be issued and a \$100.00 fee if any work starts before the permit is picked up. PHONE:		

IF THE REQUIRED INFORMATION IS NOT INCLUDED IN THE SUBMISSIONS THE PERMIT WILL BE AUTOMATICALLY DENIED AT THE DISCRETION OF THE BUILDING/PLANNING DEPARTMENT, WE MAY REQUIRE ADDITIONAL INFORMATION IN ORDER TO APPROVE THIS PERMIT.

I hereby certify that I am the Owner of record of the named property, or that the owner of record authorizes the proposed work and that I have been authorized by the owner to make this application as his/her authorized agent. I agree to conform to all applicable laws of this jurisdiction. In addition, if a permit for work described in this application is issued, I certify that the Code Official's authorized representative shall have the authority to enter all areas covered by this permit at any reasonable hour to enforce the provisions of the codes applicable to this permit

Signature of applicant: [Signature] Date: 12-20-04

**This is NOT a permit, you may not commence ANY work until the permit is issued.**  
If you are in a Historic District you may be subject to additional permitting and fees with the Planning Department on the 4<sup>th</sup> floor of City Hall

**City of Portland, Maine - Building or Use Permit**

389 Congress Street, 04101 Tel: (207) 874-8703, Fax: (207) 874-8716

Permit No: 04-1852	Date Applied For: 12/20/2004	CBL: 190 F008001
--------------------	------------------------------	------------------

Location of Construction: 91 Sewall St Owner Name: Langdon Street Real Estate Inc Owner Address: 7 Langdon St Phone:	Business Name: Langdon Street Real Estate Inc Contractor Name: Portland Pump Co. Contractor Address: P.O. Box 1180 Mussey Rd, Ext. Scarb Phone: (207) 883-4317	Lessee/Buyer's Name Phone:	Proposed Use: Concord trailways / Install 12000 gallon Diesel Storage Tank
--	--	-------------------------------	---

Proposed Project Description: Install 12000 gallon Diesel Storage Tank	
---	--

Dept: Zoning Status: Approved Reviewer: Marge Schmuckal Approval Date: 12/21/2004  
 Note:  Ok to Issue:

Dept: Building Status: Approved Reviewer: Mike Nugent Approval Date: 12/22/2004  
 Note:  Ok to Issue:

Dept: Fire Status: Approved with Conditions Reviewer: Lt. MacDougal Approval Date: 12/21/2004  
 Note:  Ok to Issue:

1) an annual permit is required from the Portland Fire Department for the storage of combustible liquids

2) the installation shall be in accordance with NFPA 30 standards



STATE OF MAINE  
DEPARTMENT OF ENVIRONMENTAL PROTECTION

JOHN ELIAS BALDACCI  
GOVERNOR

DAWN R. GALLAGHER  
COMMISSIONER

December 6, 2004

Concord Couch Lines Inc.  
7 Langdon St.  
Concord, NH 03301  
Attn: Ken Hunter

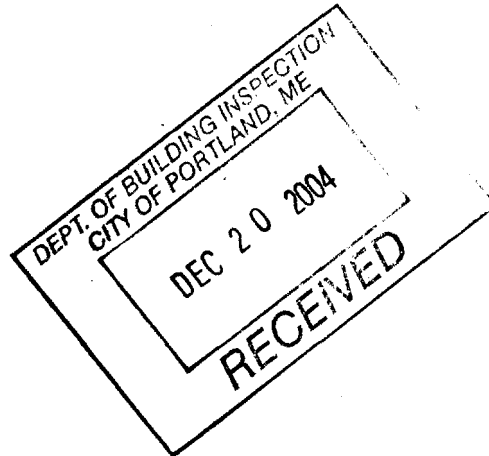

RE: Portland Transportation Center

Dear Ken:

This letter is written to acknowledge the Department's receipt of your registration materials on December 6, 2004 for either a new tank or replacement of ancillary equipment at an UST storage tank facility located at Portland Transportation Center, Portland, Maine. Maine statute dictates that the installation may take place 10 business days following notification (38 M.R.S.A., Section 563.1.A.). This installation may begin on December 20, 2004. Have a copy of your registration available and display this letter in a prominent place during construction or replacement activities.

NOTE: Please note also that the installer must complete and submit the Certification of proper Installation to the Department within 30 days of completing the work (Chapter 691(5)(B)(4)(f)). The owner is responsible for ensuring that this certification is submitted.

If you have any questions or concerns, I can be reached at (207) 287-2651

Sincerely,

John M. Dunlap  
Division of Oil and Hazardous Waste Facilities Regulation  
Bureau of Remediation and Waste Management

Cc: Scott Letellier #274

AUGUSTA  
17 STATE HOUSE STATION  
AUGUSTA, MAINE 04333-0017  
(207) 287-7688  
RAY BLDG., HOSPITAL ST.

BANGOR  
106 HOGAN ROAD  
BANGOR, MAINE 04401  
(207) 941-4570 FAX: (207) 941-4584

PORTLAND  
312 CANCO ROAD  
PORTLAND, MAINE 04103  
(207) 822-6300 FAX: (207) 822-6303

PRESQUE ISLE  
1235 CENTRAL DRIVE, SKYWAY PARK  
PRESQUE ISLE, MAINE 04769-2094  
(207) 764-0477 FAX: (207) 764.1507

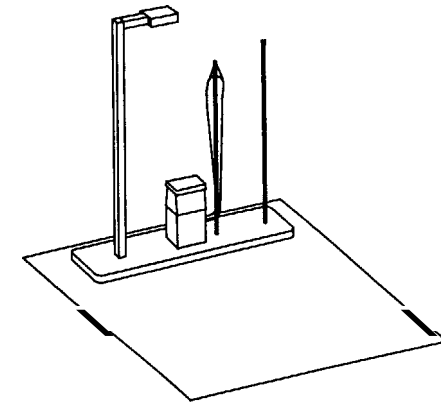
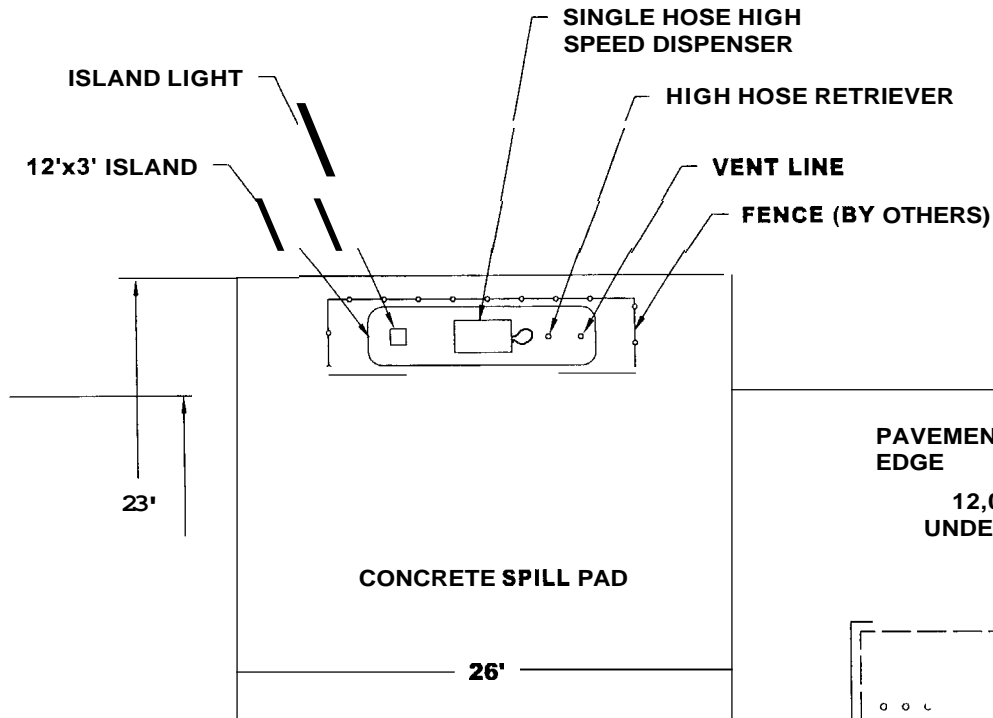

PERSPECTIVE  
NTS

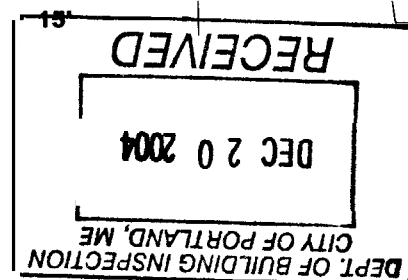
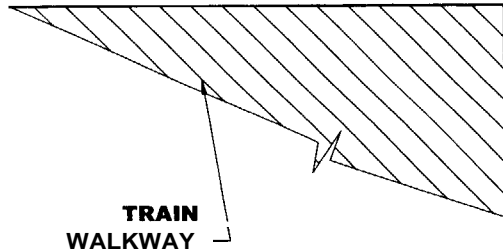
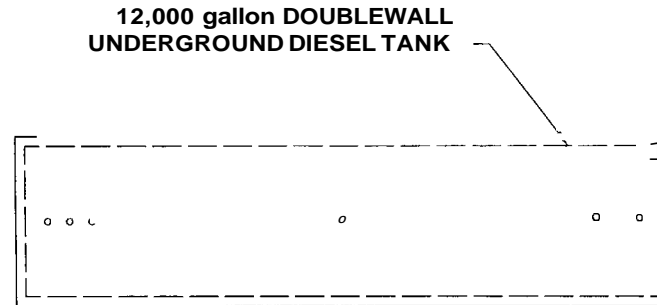

**FUEL SYSTEM SPECIALISTS**

PO Box 1180, Scarborough, ME 04070  
Ph: 207-883-4317 Fax: 207-883-1418  
WWW.PORTLANDPUMP.COM

AMTRAK & CONCORD TRAILWAYS  
PORTLAND, MAINE

**PROPOSED FUEL SYSEM**

PREPARED FOR

Revision:

DWN BY: CW

DATE: 06/03/04

DWG#: **1519**