

High Efficiency

Installation Instructions

Single Package Gas Heating/Electric Cooling
Single Phase

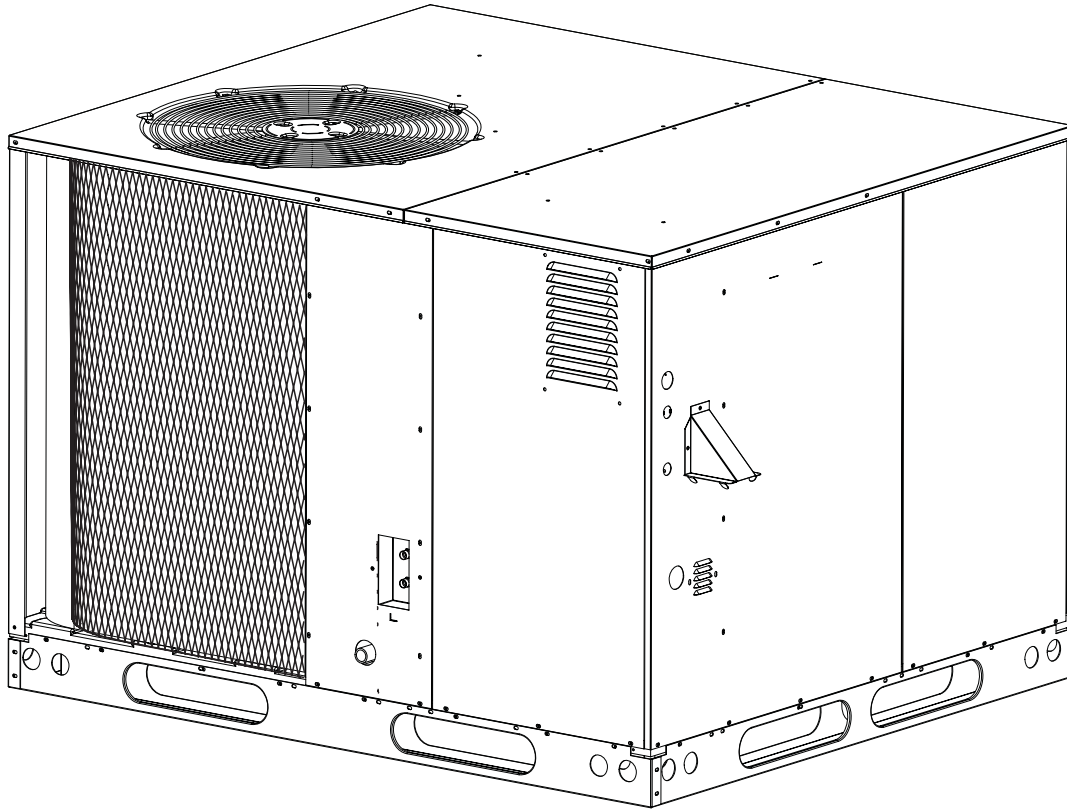

WARNING:

Improper installation, adjustment, alteration, service, or maintenance can cause injury or property damage. Refer to this manual. For assistance or additional information consult a qualified installer, service agency, or the gas supplier.

FOR YOUR SAFETY

Do not store or use gasoline or other flammable vapors and liquids in the vicinity of this or any other appliance.

FOR YOUR SAFETY WHAT TO DO IF YOU SMELL GAS

- Do not try to light any appliance.
- Do not touch any electrical switch; do not use any phone in your building.
- Immediately call your gas supplier from a neighbor's phone. Follow the gas supplier's instructions.
- If you cannot reach your gas supplier, call the fire department.
- Extinguish any open flame.

DO NOT DESTROY. PLEASE READ CAREFULLY AND KEEP IN A SAFE PLACE FOR FUTURE REFERENCE.

These instructions are primarily intended to assist qualified individuals experienced in the proper installation of this appliance. Some local codes require licensed installation/service personnel for this type of equipment. Read all instructions carefully before starting the installation.

TABLE OF CONTENTS

<p>GENERAL SPECIFICATIONS 3</p> <p>SAFETY CONSIDERATIONS 3</p> <ul style="list-style-type: none"> • Literature, Labels, and Tags 3 • Pressures Within The System 3 <p>INSTALLATION REQUIREMENTS 3</p> <ul style="list-style-type: none"> • Equipment Application 3 • Equipment Check 3 • Requirements and Codes 3 • Unit Location 3 • Venting Requirements 3 • Unit Dimensions 4-5 • Clearances to Combustible Materials 6 • Thermostat 6 • Air Filter Requirements 6 • Condensate Drain 7 <p>UNIT INSTALLATION 7</p> <ul style="list-style-type: none"> • Ground Level 7 • Rigging and Hoisting 7 • Rooftop 7 <p>AIR SUPPLY FOR COMBUSTION AND VENTILATION 9</p> <p>CIRCULATING AIR SUPPLY 9</p> <ul style="list-style-type: none"> • Unconditioned Spaces 10 • Acoustical Ductwork 10 • Horizontal to Down Flow Conversion 10 • Airflow Data 11 <p>GAS SUPPLY AND PIPING 10</p> <ul style="list-style-type: none"> • Leak Check 10 <p>GAS AND HIGH ALTITUDE CONVERSIONS 12</p> <ul style="list-style-type: none"> • High Altitude Application 12 • Natural Gas High Altitude Conversion 12 • LP/Propane Gas Conversion 12 <p>ELECTRICAL WIRING 12</p> <ul style="list-style-type: none"> • General 12 • Line Voltage 12 • Blower Speed 13 • Electrical Data Table 13 • Room Thermostat 13 	<p>SYSTEM CHECK 14</p> <ul style="list-style-type: none"> • Pre-Start Check List 14 <p>START-UP PROCEDURE 15</p> <ul style="list-style-type: none"> • Air Circulation 15 • System Cooling 15 • System Heating 15 • Verifying and Adjusting Firing Rate 15 • Verifying and Adjusting Temperature Rise 16 • Verifying Burner Operation 16 • Verifying Operation of Over-Temperature Limit Control 16 <p>WIRING DIAGRAMS 18</p> <p>COMPONENT FUNCTIONS 16</p> <ul style="list-style-type: none"> • Flame Sensor 16 • Flame Roll-Out Control 16 • Gas Valve 17 • Pressure Switch 17 • Over-Temperature Limit Control 17 <p>UNIT MAINTENANCE 17</p> <ul style="list-style-type: none"> • Refrigerant Charging 17 • Routine Maintenance 17 • Air Filter 19 • Vent Cover Assembly 19 • Condensate Drain and Outdoor Coil 19 • Electrical 19 • Motor Lubrication 19 • Blower Compartment 19 • Heat Exchanger and Burner Maintenance 19 • Cleaning of Heat Exchanger 19 • Cleaning of Burners 21 <p>OPERATING SEQUENCE 22</p> <ul style="list-style-type: none"> • Cooling Mode 22 • Blower Mode 22 • Heating Mode 22 • Unit Fails to Operate 23 <p>CHARGING CHARTS 24-26</p> <p>INSTALLATION CHECKLIST 27</p>
---	---

GENERAL SPECIFICATIONS

Single Package Gas Heating/Electric Cooling units are designed for outdoor rooftop or ground level slab installations. The units are shipped ready for horizontal duct connections and are easily converted for down flow connections.

All models are shipped from the factory with the following:

1. Multispeed fixed torque variable speed blower.
2. Horizontal or down flow duct connections.
3. 24V fuse protection.
4. High Pressure Switch.

The unit dimensions are shown in **Figure 1**.

SAFETY CONSIDERATIONS

It is the responsibility of the installer to ensure that the installation is made in accordance with all applicable local and national codes.

WARNING:

Improper installation, service, adjustment, or maintenance may cause explosion, fire, electrical shock or other hazardous conditions which may result in personal injury or property damage. Unless otherwise noted in these instructions, only factory authorized kits or accessories may be used with this product.

Literature, Labels, and Tags — When working with this equipment, follow all precautions in the literature, on tags, and on labels provided with the unit and/or approved field installed kits. The type of hazard and severity are described on each label or tag.

Pressures Within The System — This equipment contains liquid and gaseous R410a refrigerant under high pressure. Installation or servicing should only be performed by qualified trained personnel thoroughly familiar with this type equipment.

CAUTION:

This unit uses refrigerant R-410A. DO NOT under any circumstances use any other refrigerant besides R-410A in this unit. Use of another refrigerant will damage this unit.

INSTALLATION REQUIREMENTS

Equipment Application — Before beginning the installation, verify that the unit model is correct for the job. The unit model number is printed on the data label. This furnace is **NOT** to be used for temporary heating of buildings or structures under construction.

Equipment Check — All units have been securely packaged at the point of shipment. After unpacking the unit, carefully inspect it for apparent and concealed damage. Claims for damage should be filed with the carrier by the consignee.

Requirements and Codes — The installer must comply with all local codes and regulations which govern this type equipment. Local codes and regulations take precedence over any recommendations contained in these instructions. In the absence of local codes, the installation must conform with the National Fuel Gas Code (ANSI 2223.1, NFPA-54), or Canadian installations must conform with CAN/CGA-B149 installation codes. All electrical wiring must be made in accordance with codes and regulations and with the National Electric Code (ANSI/NFPA 70) or in Canada the Canadian Electric Code Part 1 CSA C.22.1. Air Ducts must be installed in accordance with the standards of the National Fire Protection Association “Standards for Installation of Air Conditioning and Ventilation Systems” (NFPA 90A), “Standard for Installation of Residence Type Warm Air Heating and Air Conditioning Systems” (NFPA 90B), these instructions, and all applicable local codes.

The National Fuel Gas Code is available by writing:

American National Standards Institute, Inc.
1430 Broadway
New York, NY 10018

NFPA publications are available by writing:

National Fire Protection Association
Batterymarch Park
Quincy, ME 02269

Unit Location — The gas/electric unit is designed only for outdoor installations. Choosing the location of the unit should be based on minimizing the length of the supply and return ducts. Consideration should also be given to availability of fuel, electric power, service access, noise, and shade.

Venting Requirements — This unit has been equipped with an integral venting system and designed to operate only with this venting system. No additional venting shall be used. This unit must be vented to the outdoors.

DIMENSIONS

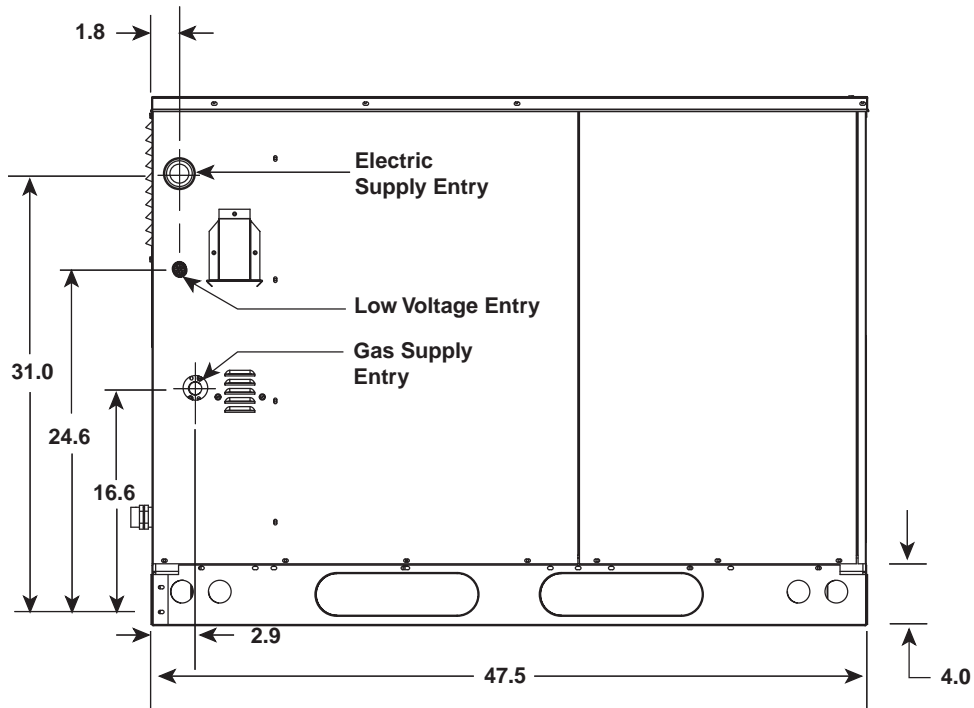

Side View

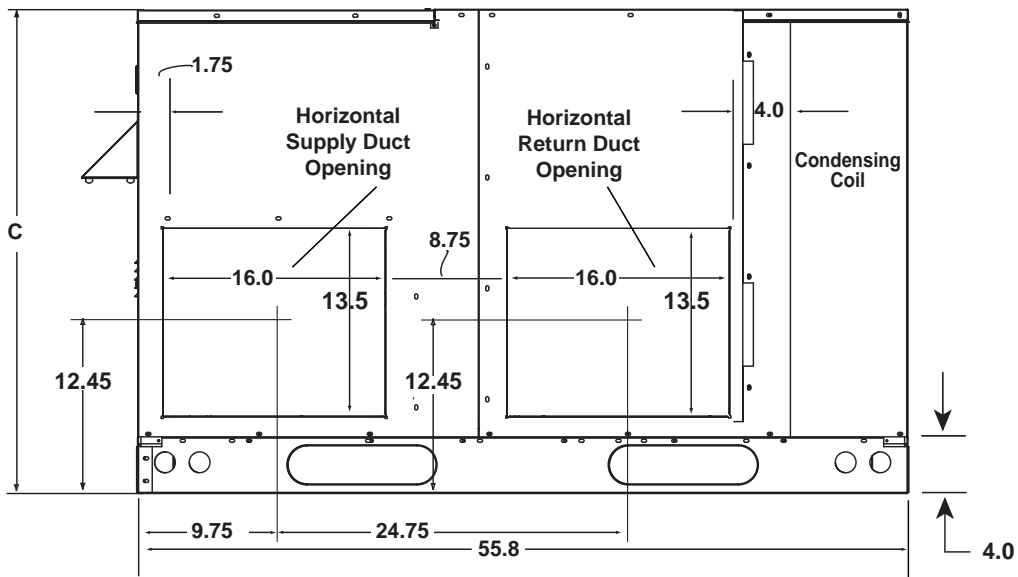

Back View

DIMENSIONS - Continued

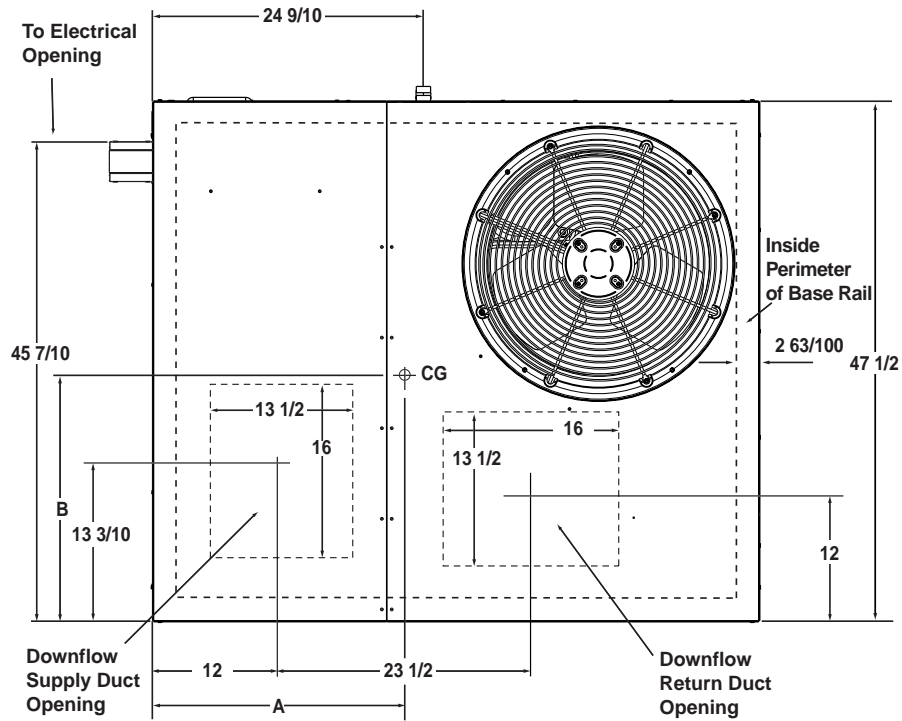

Top View

Model Number R6GD	Unit Weight	Shipping Weight	Center of Gravity		Height (in inches)	
			A	B	C	
					with base rails	without base rails
X24K045†	425	435	26.5	26.5	39.0	35.3
X24K072†	435	445	26.0	26.5	39.0	35.3
X30K045†	430	440	26.5	26.5	39.0	35.3
X30K072†	440	450	26.0	26.5	39.0	35.3
X36K072†	470	480	26.5	26.5	39.0	35.3
X36K096†	485	495	26.5	26.5	39.0	35.3
X42K072†	495	505	27.0	26.5	39.0	35.3
X42K096†	510	520	27.0	26.5	39.0	35.3
X48K096†	540	550	27.5	26.5	43.0	39.3
X48K120†	555	565	27.5	26.5	43.0	39.3
X60K096†	560	570	27.5	26.5	43.0	39.3
X60K120†	575	585	27.5	26.5	43.0	39.3

† Denotes either "C" or "X"

! WARNING:

Do not vent furnace through a conventional venting system.

A vent cover assembly has been supplied with the unit. It can be found secured to the gas controls within the control area of this unit. **Figure 2** shows the proper installation of the vent cover assembly over the vent outlet on the exterior of the corner panel. The fasteners used to secure the vent cover assembly have been included in the homeowner's package.

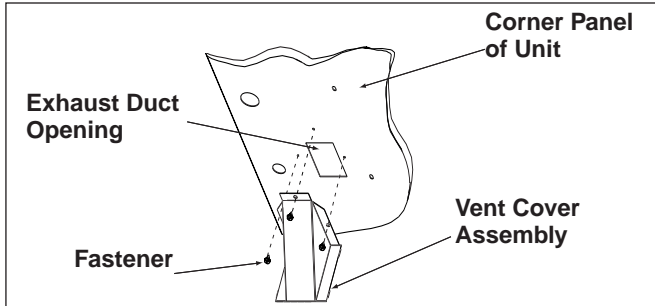

Figure 2. Vent Assembly

! WARNING:

The vent cover assembly must be installed to assure proper operation of the unit.

The following list is a summary of the requirements for the location of the termination of the venting system:

1. The location of the vent termination must be consistent with the National Fuel Gas Code (ANSI Z223.1) or CAN/CGA-B149 Installation Codes.
2. The vent termination must be located at least four (4) feet horizontally from any electric meters, gas meters, regulators, and relief equipment.
3. The vent termination must be located at least three (3) feet above any forced air inlet located within ten (10) feet.
4. The vent termination must be located at least four (4) feet below, four (4) feet horizontally from, or one (1) foot above any door, window, or gravity air inlet into any building.
5. The vent termination must be located at least one (1) foot above grade.

6. The unit should be installed in such a manner as to prevent snow accumulation from obstructing the vent termination.
7. The unit installation shall avoid areas where condensate drainage may cause problems by dropping on planters or patios, etc. Furthermore, ensure that the exhaust gases will not impinge on windows or building surfaces, which may be compromised or damaged by condensation. Do not install the unit such that exhaust from the vent termination is directed into window wells, stairwells, under decks, or in alcoves or similarly recessed areas. The vent termination must not be located above any public walkways.

Clearances to Combustible Materials — See **Table 2** for required clearances to combustible materials. Refer to the unit data label for the model number. The gas/electric unit is suitable for installation on combustible flooring or class A, B, or C roofing materials. A clearance of at least 36 inches from the blower access panel and from the louvered control access panel is recommended to allow for servicing and maintenance. **Where accessibility to combustibles clearances are greater than minimum clearances, accessibility clearances must take preference.** Sufficient clearance for unobstructed airflow through the louvered control access panel and through the outdoor coil must be maintained in order to achieve rated performance. See **Figure 3** for minimum clearances to obstructions.

Thermostat — A single stage cooling/single stage heating 24VAC thermostat should be used with these units. A two-stage cooling/single-stage heating thermostat is recommended for economizer operation.

Air Filter Requirements — A suitable air filter system must be installed in the unit or in the return air system upstream of the evaporator coil. Refer to **Table 1** for recommended filter sizes. Air filter pressure drop must not exceed 0.08 inches WC. This unit is not supplied with air filter(s) and has no factory equipped means for accommodating internal air filter(s).

! WARNING:

Never operate unit without a filter. A failure to follow this warning could result in a fire, personal injury, or death.

Nominal Cooling Tonnage (Ton)	Approximate Air Flow Range (CFM)	Approximate Filter Area (Sq. In.)*		Recommended Filter Size (In. x In.)	
		Disposable	High Velocity	Disposable	High Velocity
2.0	600-900	450	275	20 x 25	15 x 20
2.5	750-1200	550	325	20 x 30	16 x 20
3.0	1100-1300	625	375	25 x 25	20 x 20
3.5	1200-1600	750	450	24 x 30	20 x 25
4.0	1400-1800	850	500	18 x 24 (2 required)	20 x 25
5.0	1800-2200	1000	625	20 x 25 (2 required)	25 x 25

* Based on a velocity of 300 ft/min for disposable filters and 500 ft/min for high velocity (cleanable) filters

Table 1. Air Filter Requirements

For single phase downflow installations only, an internal filter accessory kit can be ordered. For horizontal installations, the air filter system must be installed in the return air ductwork. All return air to this unit must pass through the filter(s) before entering the evaporator coil.

IMPORTANT NOTICE TO INSTALLER: After installing or replacing the filtration system for this unit, add the following marking on the filter service panel or reasonably adjacent thereto: **“Replace filter(s) installed in your system only with the same dimensional size filters that are being replaced.”**

Condensate Drain — Condensate is removed from the unit through the 3/4" female pipe fitting located on the front side of the unit. (See **Figure 4**.) Install a 2 inch deep condensate trap in the drain line of the same size and prime with water.

When connecting rigid drain line, hold the female fitting with a wrench to prevent twisting. **Do not over tighten!** Refer to local codes and restrictions for proper condensate disposal requirements.

UNIT INSTALLATION

Ground Level — When installing the unit at ground level (See **Figure 5**), provide a concrete mounting pad separate from the building foundation. The pad must be level to insure proper condensate disposal and strong enough to support the unit's weight (Refer to **Figure 1**). Make sure the slab is a minimum of 2" above the grade and in an area that drains well.

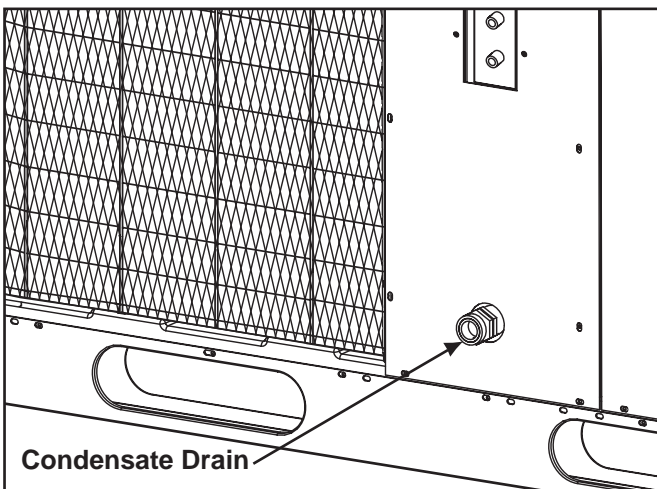

Figure 4. Condensate Drain.

Rigging and Hoisting — The unit should be lifted using slings and spreader bars. The spreader bars are necessary to prevent damaging the top of the unit's cabinet. Make sure that the lifting equipment is adequate for the load. Refer to **Figure 1** for unit weights. Keep the unit in an upright position at all times. The rigging must be located outside the unit's center of gravity. Refer to **Figure 1** for center of gravity location. **For rooftop installations, remove and discard the two supports attached beneath the unit.**

! WARNING:

To avoid the risk of property damage or personal injury, it is the rigger's responsibility to ensure that whatever means are used to hoist the unit are safe and adequate.

! CAUTION:

All panels must be securely in place when rigging and hoisting.

Rooftop — For rooftop installations (See **Figure 6**) use the appropriate accessory roof curb and follow all instructions included with it. Make sure the supports beneath the unit have been removed. Locate the unit according to local building codes and ordinances. The curb must be level to insure proper condensate drainage.

The roof must be capable of handling the weight of the unit. See **Figure 1** for unit weights. Reinforce the roof if required.

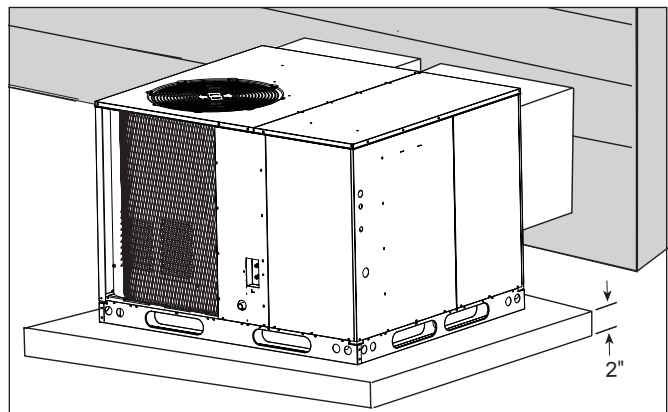

Figure 5. Ground Level Installation.

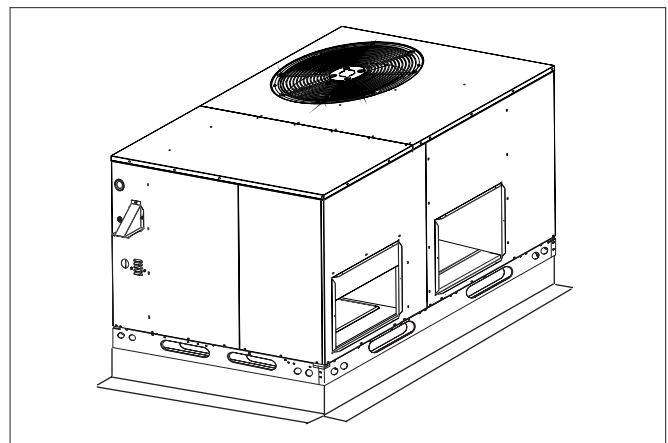

Figure 6. Roof Curb Installation.

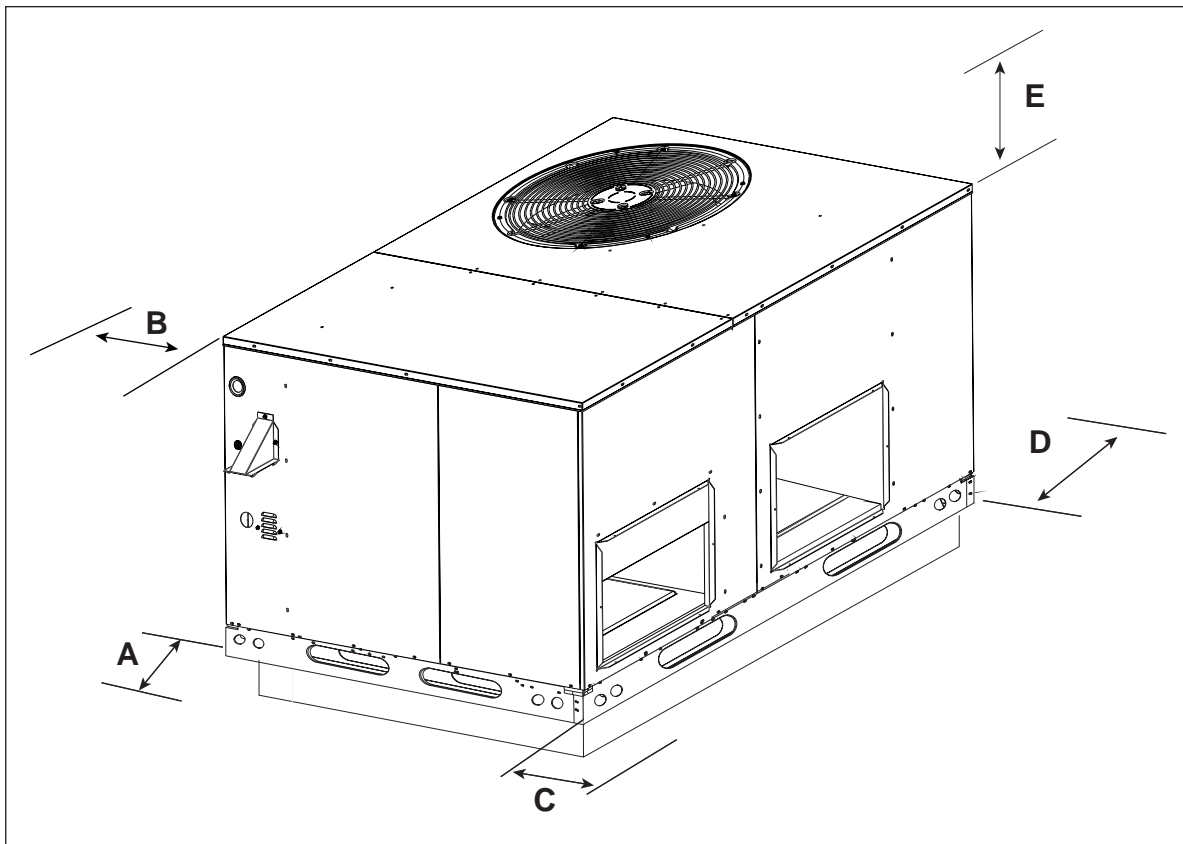

Figure 3. Minimum Clearances.

Minimum Clearances to Combustible Material**						
Model Number R6GD	Heating Input (Btuh)	Minimum Clearances (Inches)				
		Blower	Control	Duct	Coil	
		Panel (A)	Panel (B)	Panel (C)	End (D)	Top (E)
X24(K)045(†)	45,000	36	36	1*	36	36
X24(K)072(†)	72,000	36	36	1*	36	36
X30(K)045(†)	45,000	36	36	1*	36	36
X30(K)072(†)	72,000	36	36	1*	36	36
X36(K)072(†)	72,000	36	36	1*	36	36
X36(K)096(†)	96,000	36	36	1*	36	36
X42(K)072(†)	72,000	36	36	1*	36	36
X42(K)096(†)	96,000	36	36	1*	36	36
X48(K)096(†)	96,000	36	36	1*	36	36
X48(K)120(†)	120,000	36	36	1*	36	36
X60(K)096(†)	96,000	36	36	1*	36	36
X60(K)120(†)	120,000	36	36	1*	36	36

* If accessories (filters, economizers, fresh air dampers . . .) are installed, see accessory installation instructions for proper clearances.

**Suitable for installation on combustible flooring or class A, B, or C roofing material.

† Can be C or X.

Table 2. Minimum Clearances to Combustible Materials.

 **WARNING:**

Do not place combustible material on or against the unit cabinet. Do not place combustible materials, including gasoline and any other flammable vapors and liquids, in the vicinity of the unit.

AIR SUPPLY FOR COMBUSTION AND VENTILATION

Provisions must be made in the installation of this unit to provide an adequate supply of air for combustion. Detailed instructions for determining the adequacy of an installation can be found in the current revision of the National Fuel Gas Code (ANSI Z223.1) and NFPA 54, or in Canadian installation codes (CAN/CGA-B149), or in applicable local building codes. Consult local codes for special requirements.

 **WARNING:**

Installation using methods other than those described in the following sections must comply with the National Fuel Gas Code and all applicable local codes to provide sufficient combustion air for the furnace.

If the unit is operated with inadequate combustion air supply the flame roll-out control located above the burners will open, turning off the gas supply to the burners. The flame roll-out control is a manually re-settable device. DO NOT install a jumper wire across this control to defeat its function. DO NOT reset the control without identifying and correcting the fault condition which caused the control to trip. If this control must be replaced, use only the replacement part specified in the Replacement Parts List.

Air Openings in the door of the unit, warm air registers, and return air grilles must not be restricted.

To maximize heat exchanger life, the combustion air must be free of chemical contaminants which form corrosive acidic compounds when combusted. Some examples of these chemical contaminants are chlorine, fluorine, and sulphur. Some common sources of these chemical contaminants are detergents, bleaches, aerosol sprays, cleaning solvents, and a wide variety of commercial and household products.

 **WARNING:**

Combustible air must not be drawn from a contaminated atmosphere. Excessive exposure to contaminated combustion air will result in safety and performance related problems.

CIRCULATING AIR SUPPLY

 **WARNING:**

Products of combustion must not be allowed to enter the return air ductwork or the circulating air supply. Failure to prevent products of combustion from being circulated into the living space can create potentially hazardous conditions including carbon monoxide poisoning that could result in personal injury or death.

All return ductwork must be adequately sealed, all joints must be taped, and the ductwork must be secured to the unit with sheet metal screws. When return air is provided through the bottom of the unit, the joint between the unit and the return air plenum must be air tight.

The roof curb or cement pad on which the unit is mounted must provide sound physical support of the unit with no gaps, cracks, or sagging between the unit and the curb or pad.

Return air and circulating air ductwork must not be connected to any other heat producing device such as a fireplace insert, stove, etc. Doing so may result in fire, explosion, carbon monoxide poisoning, personal injury, or property damage.

This unit is designed only for use with a supply and return duct. Air ducts should be installed in accordance with all applicable local codes and the standards of the National Fire Protection Association "Standard for Installation of Air Conditioning Systems" (NFPA 90A), and "Standard for Installation of Residence Type Warm Air Heating and Air Conditioning Systems" (NFPA 90B).

Design the ductwork according to methods described by the Air Conditioning Contractors of America (ACCA) Manual D. The ducts must be properly sized not to exceed 0.2 inches WC pressure drop at 400 scfm per nominal ton of cooling capacity.

Ductwork should be attached directly to the unit flanges for horizontal applications. On roof curb installations the ducts must be attached to the curb duct supports, not the unit.

It is recommended that the outlet duct be provided with a removable access panel. This opening should be accessible when the unit is installed in service and shall be of a size such that the smoke or reflected light may be observed inside the casing to indicate the presence

of leaks in the heat exchanger. The cover for the opening shall be attached in such a manner as to prevent leaks.

If outside air is utilized as return air to the unit for ventilation or to improve indoor air quality, the system must be designed so that the return air to the unit is not less than 50°F (10°C) during heating operation. If a combination of indoor and outdoor air is used, the ducts and damper system must be designed so that the return air supply to the furnace is equal to the return air supply under normal, indoor return air applications.

Unconditioned Spaces — All ductwork passing through unconditioned space must be properly insulated to minimize duct losses and prevent condensation. Use insulation with an outer vapor barrier. Refer to local codes for insulation material requirements.

Acoustical Ductwork — Certain installations may require the use of acoustical lining inside the supply ductwork. Acoustical insulation must be in accordance with the current revision of the Sheet Metal and Air Conditioning Contractors National Association (SMACNA) application standard for duct liners. Duct lining must be UL classified batts or blankets with a fire hazard classification of FHC-25/50 or less. Fiber ductwork may be used in place of internal duct liners if the fiber ductwork is in accordance with the current revision of the SMACNA construction standard on fibrous glass ducts. Fibrous ductwork and internal acoustical lining must be NFPA Class 1 air ducts when tested per UL Standard 181 for Class 1 ducts.

Horizontal to Down flow Conversion — The unit is shipped ready for horizontal duct connections. If down flow ducts are required, the unit must be converted following the steps below for both the supply and return ducts.

1. Locate the duct cap inside the duct openings and remove the screw holding it in place.
2. Lift the cap out of the unit. The cap can be pushed up from the bottom by reaching through the fork slot.
3. Cover the horizontal duct opening with the cap. The insulation will be on the indoor side.
4. Fasten the cover with screws and seal to prevent air leakage.

GAS SUPPLY AND PIPING

This unit has right side gas entry. A typical gas service hookup is shown in **Figure 7**. When making the gas

connection, provide clearance between the gas supply line and the entry hole in the unit's casing to avoid unwanted noise and/or damage to the unit.

All gas piping must be installed in compliance with local codes and utility regulations. Some local regulations require the installation of a manual main shut-off valve and ground joint union external to the unit. The shut-off valve should be readily accessible for service and/or emergency use. Consult the local utility or gas supplier for additional requirements regarding placement of the manual main gas shut-off. In the absence of local codes the gas line installation must comply with the latest edition of the National Fuel Gas Code ANSI Z223.1 or CAN/CGA B149 Installation Codes.

CAUTION:

Do not use matches, lighters, candles or other sources of open flame to check for gas leaks.

A 1/8 inch NPT plugged tap must be installed in the gas line immediately upstream of the gas supply connection to the furnace for use when measuring the gas supply pressure. The plug should be readily accessible for service use. A drip leg should be installed in the pipe run to the unit. **Table 4** lists gas flow capacities for standard pipe sizes as a function of length in typical applications based on nominal pressure drop in the line.

IMPORTANT NOTES:

1. Gas piping must not be run in or through air ducts, chimneys, gas vents, elevator shafts, etc.
2. Compounds used on threaded joints of gas piping must be resistant to the actions of liquefied petroleum gases.
3. The main manual gas valve and main power disconnect to the furnace must be properly labeled by the installer in case emergency shutdown is required.

Leak Check — After the gas piping to the unit is complete, all connections must be tested for gas leaks. To check for leaks in gas piping systems, use only a soap and water solution or other approved method.

IMPORTANT NOTE: When pressure testing the gas supply lines at pressures greater than 1/2 psig (14 inches WC), the unit must be disconnected from the gas supply piping system to prevent damage to the gas control valve.

If the test pressure is less than or equal to 1/2 psig (14 inches WC), the unit must be isolated from the gas supply line by closing the manual shut-off valve.

⚠ WARNING:

This unit was equipped at the factory for use with natural gas only. A special kit, supplied by the manufacturer, is required to convert the unit to operate on LP/propane gas. Failure to use the proper conversion kit can cause fire, explosion, property damage, carbon monoxide poisoning, personal injury, or death.

GAS AND HIGH ALTITUDE CONVERSIONS

Conversion: conversion of this unit must be performed by qualified service personnel, using only approved parts.

High Altitude Application

High altitude application with this furnace can be field performed by a simple adjustment of manifold pressure and if necessary, a change of the orifices. The changes required depend on the installation altitude and the heating value of the gas. The gas heating value based on sea level can be obtained from your local gas utility. The heating value of gas at high altitude is always lower than the sea level heating value. The heating values used in the **Tables 5 & 6** are based on sea level values.

Natural Gas High Altitude Conversion

All factory shipped furnaces are ready to operate between zero and 4999 ft. above sea level. For higher altitudes (between 5000 and 10,000 ft. above sea level), conversion can be achieved simply by adjusting the furnace manifold pressure as shown in **Table 5**.

LP/Propane Gas Conversion

IMPORTANT NOTE: When converting a low NOx Furnace from Natural gas to LP/Propane gas, it is necessary to remove the NOx Baffles.

Conversion of this furnace to utilize LP/Propane gas must be made by qualified service personnel, using approved parts. Conversion for the LP/Propane gas can be accomplished by adjusting the manifold pressure, after replacing the natural gas orifices with the appropriate LP/Propane orifices shown in **Table 6**. Note: that for installations between zero and 5000 ft. above sea level, a #54 drill size orifice should be used. However for installations above 5000 ft. over sea level, a #55 drill size orifice should be used. Then use **Table 6** to determine the appropriate manifold pressure for your altitude installation. Conversion to LP/Propane (sea level and high altitude) is detailed in the installation instructions provided with the conversion kit. Approved conversion kits are:

United States LP/Propane Gas Sea Level and High Altitude Conversion Kit - P/N 904090A

This kit is for LP/propane conversion in the United States

at altitudes between zero and 10,000 ft. above sea level. Follow the installation instructions supplied with the kit for proper installation.

Canadian LP/Propane Gas Sea Level and High Altitude Conversion Kit - P/N 904091A. This kit is for LP/propane conversions in Canada at altitudes between zero and 4500 ft. above sea level. Follow the installation instructions supplied with the kit for proper installation.

⚠ WARNING:

To avoid the risk of electrical shock, personal injury, or death, disconnect all electrical power to the unit before performing any maintenance or service. The unit may have more than one electrical power supply.

⚠ WARNING:

The unit cabinet must have an uninterrupted or unbroken electrical ground to minimize personal injury if an electrical fault should occur. This ground may consist of electrical wire or approved conduit when installed in accordance with existing national or local codes.

ELECTRICAL WIRING

General — Electrical power wiring must be made in accordance with all applicable local codes and ordinances, and with the current revision of the National Electric Code NFPA 70 or in Canada CSA C.22.1 Canadian Electrical Code Part 1. If any of the original wire as supplied with the unit must be replaced, it must be replaced with material of the same gauge and temperature rating.

Line Voltage — Before proceeding with the electrical connections, make certain that the voltage, frequency and phase of the supply source are the same as those specified on the unit rating plate. Also verify that the service

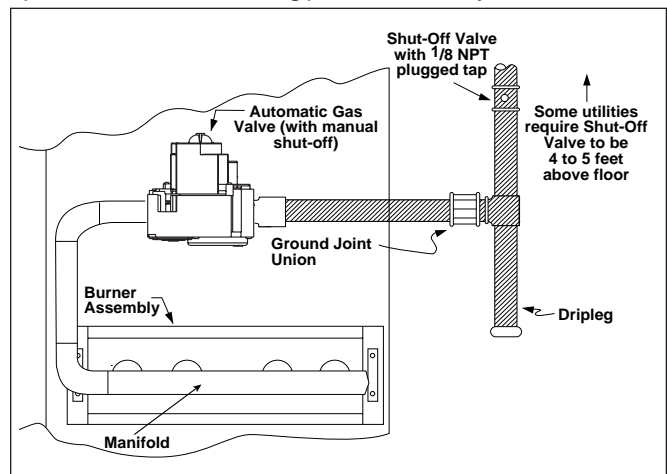

Figure 7. Typical Right Side Entry Gas Service Connection.

provided by the utility is sufficient to handle the additional load imposed by this equipment.

This unit must be electrically grounded in accordance with local codes or, in the absence of local codes, with the National Electrical Code (ANSI/NFPA 70) or the CSA C22.1 Electrical Code.

See **Figure 10** or the unit wiring label for proper high and low voltage wiring. Make all electrical connections in accordance with all applicable codes and ordinances.

Use a separate branch electrical circuit for this unit. A means of electrical disconnect must be located within sight of and readily accessibility to the unit.

The unit is shipped from the factory wired for 240 volt transformer operation. For 208 volt operation, remove the lead from the transformer terminal marked 240V and connect it to the terminal marked 208V. For maximum circuit ampacity and maximum over current protection, see the unit rating plate or **Table 7**.

Overcurrent protection must be provided at the branch circuit distribution panel and sized as shown in **Table 7** or on the unit rating label and according to the National Electric Code and applicable local codes.

Provide power supply (or supplies) for the unit in accordance with the unit wiring diagram, and the unit rating plate. Connect the line-voltage leads to the corresponding terminals on the contactor inside the control compartment. Use only copper wire for the line voltage power supply to this unit. Use proper code agency listed conduit and a conduit connector for connecting the supply wires to the unit and for obtaining proper grounding. Grounding may also be accomplished by using the grounding lug provided in the control box. Do not use gas piping as an electrical ground.

! CAUTION:

To avoid personal injury or property damage, make certain that the motor leads cannot come into contact with any uninsulated metal components of the unit.

Blower Speed — The blower speeds are preset at the factory. See **Table 3** for factory settings. For optimum system performance and comfort, it may be necessary to change the factory set speed. To change the blower speed:

1. Disconnect all electrical power to the unit and remove the blower panel.
2. Locate the orange, red and blue wires terminated to the blower motor. The orange wire controls cooling operation while the red wire controls heating operation. The blue wire controls fan-only operation.
3. Verify the required speed from the airflow data found in table 3. Place appropriate wire on the appropriate motor speed tap for the required airflow point.

4. The integrated furnace control can be set in a 2 or 3 speed mode. When a “G” only call is received from the thermostat indicating a continuous fan mode, the blower will run the heating speed when the “2-SPD” mode is selected using the jumper on the control board (factory setting). When “3-SPD” mode is selected, the fan only speed can be different than the heating or cooling speed. If no jumper is present, the control defaults to the “2-SPD” mode of operation. A call for heating or cooling takes priority over fan only mode.

Check all factory wiring per the unit wiring diagram and inspect the factory wiring connections to be sure none loosened during shipping or installation.

Room Thermostat — Several options are available for a room thermostat depending on the accessories installed with the unit. Select a thermostat which operates in conjunction with the installed accessories. The thermostat should be mounted about five feet above the floor on an inside wall. The thermostat should be kept away from drafts, slamming doors, lamps, direct sunlight and the supply air flow.

To install the thermostat:

1. Position the subbase on an inside wall and mark the mounting holes and thermostat cable openings.
2. Cut out the cable opening and route the thermostat cable from the unit’s low voltage compartment to the thermostat location. The thermostat cable is supplied by the installer.

CAPACITY OF BLACK IRON GAS PIPE (CU. FT. PER HOUR) FOR NATURAL GAS (SPECIFIC GRAVITY - 0.60)								
NOMINAL BLACK IRON PIPE DIA. (in.)	LENGTH OF PIPE RUN (feet)							
	10	20	30	40	50	60	70	80
1/2	130	90	75	65	55	50	45	40
3/4	280	190	150	130	115	105	95	90
1	520	350	285	245	215	195	180	170
1 1/4	1050	730	590	500	440	400	370	350
1 1/2	1600	1000	890	760	670	610	560	530

The cubic feet per hour listed in the table above must be greater than the cubic feet per hours of gas flow required by the unit.

To determine the cubic feet per hour of gas flow required by the unit, divide the input rate of the unit by the heating value of the gas:

$$\text{Cubic Feet Per Hour Required} = \frac{\text{Input To Unit (Bth/hr)}}{\text{Heating Value of Gas (Btu/Cu. Ft.)}}$$

Table 4. Capacity of Black Iron Gas Pipe (cubic feet per hour) for Natural Gas (specific gravity = .60).

For a Natural Gas Sea Level Heating Value of 800 to 899 Btu/ cu.ft.					
	Elevation (feet above sea level)				
	zero to 1999	2000 to 4999	5000 to 5999	6000 to 7999	8000 to 10000
Manifold Pressure Setting (in WC)	3.5	3.5	3.5	3.5	3

For a Natural Gas Sea Level Heating Value of 900 to 999 Btu/ cu.ft.					
	Elevation (feet above sea level)				
	zero to 1999	2000 to 4999	5000 to 5999	6000 to 7999	8000 to 10000
Manifold Pressure Setting (in WC)	3.5	3.5	3.5	3.2	2.8

For a Natural Gas Sea Level Heating Value of 1000 to 1100 Btu/ cu.ft.					
	Elevation (feet above sea level)				
	zero to 1999	2000 to 4999	5000 to 5999	6000 to 7999	8000 to 10000
Manifold Pressure Setting (in WC)	3.5	3.5	3	2.8	2.5

Table 5. Manifold Pressure (in WC) for Natural Gas at Various Altitudes and Heating Values

	Elevation (feet above sea level)				
	zero to 1999	2000 to 4999	5000 to 5999	6000 to 7999	8000 to 10000
Manifold Pressure in (WC) Based on Sea Level LP Heating Value of 2,500 Btu/ft.3	10	8.5	10	9	8.5
Orifice Size	54	54	55	55	55

Table 6. Manifold Pressure (in WC) for LP/Propane Gas at Various Altitudes

3. Connect the cable leads to the subbase or thermostat terminals and to the unit's low voltage connector on the furnace board as shown in **Figure 9**. A system wiring diagram is also provided on the inside of the louvered control access panel and in **Figure 10** of these installation instructions.
 4. Secure the subbase or thermostat to the wall using screws provided with the thermostat.
 5. If subbase is used, install the correct thermostat housing to subbase.
 6. Refer to thermostat instruction sheet for complete detailed mounting information.
- Verify that the line voltage power leads are securely connected and the unit is properly grounded.
 - Verify that the low voltage wires are securely connected to the correct leads in the low voltage area of the control box.
 - Verify that the gas line service pressure does not exceed 10.0 inches WC (0.36 psig), and is not less than 4.5 inches WC (0.16 psig) for natural gas. For LP gas the line service pressure must not exceed 14 inches WC (0.51 psig) and must not be less than 11.0 inches WC (0.40 psig).
 - Verify that the flame roll-out control is closed. If necessary, press the red button to reset the control. DO NOT install a jumper wire across the control to defeat its function. If the control reopens upon start-up, DO NOT reset the control without identifying and correcting the fault condition which caused the control to trip.
 - Verify that the gas line has been purged and all connections are leak tight.
 - Verify that all exterior panels are replaced and securely fastened.
 - Verify that the outdoor fan turns freely.
 - Verify that the power supply branch circuit overcurrent protection is sized properly.
 - Verify that the thermostat is wired correctly. The thermostat function switch should be set to "Off" and the thermostat fan switch should be set to "Auto."

To determine the heat anticipator setting, either:

1. Add the current draw of the system components or,
2. Measure the current flow on the thermostat R-W circuit after the circulating blower motor has started.

SYSTEM CHECK

Pre-Start Check List

- Verify that the unit is level to allow proper condensate drainage.
- Verify that there is free airflow to and from the outdoor coil and that all clearance requirements are met.
- Verify that the ductwork is sealed to prevent air leakage.

WARNING:

If the unit is equipped with a crankcase heater, allow 24 hours prior to continuing the start up procedures to allow for heating of the refrigerant compressor crankcase. Failure to comply may result in damage and could cause premature failure of the system. This warning should be followed at initial start up and any time the power has been removed for 12 hours or longer.

CAUTION:

This unit uses refrigerant R-410A. DO NOT under any circumstances use any other refrigerant besides R-410A in this unit. Use of another refrigerant will damage this unit.

START-UP PROCEDURE

Close all electrical disconnects to energize the system.

Air Circulation — Leave the thermostat system switch set to “Off” and set the thermostat fan switch to “On.” The blower motor should run continuously. Check for air delivery at the register(s). Ensure that there are no obstructions at the registers or in the ductwork. Set thermostat fan switch to “Auto,” the blower will shut down in 60 seconds.

System Cooling

1. Set the thermostat system switch to “Cool” and the thermostat fan switch to “Auto.” Gradually lower the thermostat temperature switch below room temperature and observe that the blower, compressor and fan energize. Check that air cooler than room temperature is being discharged at the register. Listen for any unusual noises. Locate the source and correct as needed.
2. After allowing the unit to run for several minutes, set the temperature selector above room temperature, verify that:

- a. The fan and compressor cycle off with the thermostat.
- b. The blower also stops after the 85 second delay.

System Heating

1. Set the thermostat to the lowest setting.
2. Follow the procedures given on the operating instruction label, in this installation instructions or attached inside the louvered control access panel.
3. Set the thermostat above room temperature and verify the sequence of operation. (See Operating Sequence on page 25.)
4. Verify that the compressor and outdoor fan motor are not energized.
5. After the unit has run for approximately five minutes, set the thermostat below room temperature and verify the shutdown sequence. (See Operating Sequence on page 25.)

Verifying and Adjusting Firing Rate — The firing rate must be verified for each installation to prevent over-firing of the furnace.

CAUTION:

Do not re-drill the burner orifices. If the orifice size must be changed, use only new orifices.

IMPORTANT NOTE: The firing rate must not exceed the rate shown on the unit data label. At altitudes above 2,000 ft. it must not exceed that on the data label less 4% for each 1,000 ft.

Follow the procedure below to determine the firing rate:

1. Shut off all other gas fired appliances.
2. Start the unit in heating mode and allow it to run for at least three minutes.
3. Measure the time (in seconds) required for the gas meter to complete one revolution.
4. Convert the time per revolution to cubic feet of gas per hour using **Table 8**.

Model Number	Heating Input (BTUh)	Nominal Electrical Supply	Voltage Range		Compressor		Fan Amps	Blower Motor Amps	Minimum Circuit Ampacity	Maximum Over-current Protection
			Min.	Max.	RLA	LRA				
R6GD-X24K	45,000	208/-23-60-1	187	253	12.8	58.3	1.2	4.1	22.7	35
	72,000	208/-23-60-1	187	253	12.8	58.3	1.2	4.1	22.7	35
R6GD-X30K	45,000	208/-23-60-1	187	253	15.7	73.0	1.2	4.1	26.3	40
	72,000	208/-23-60-1	187	253	15.7	73.0	1.2	4.1	26.3	40
R6GD-X36K	72,000	208/-23-60-1	187	253	18.6	79.0	1.2	4.1	29.9	45
	96,000	208/-23-60-1	187	253	18.6	79.0	1.2	4.1	29.9	45
R6GD-X42K	72,000	208/-23-60-1	187	253	22.1	109.0	1.2	6	36.2	50
	96,000	208/-23-60-1	187	253	22.1	109.0	1.2	6	36.2	50
R6GD-X48K	96,000	208/-23-60-1	187	253	24.3	117.0	1.2	6	39.0	60
	120,000	208/-23-60-1	187	253	24.3	117.0	1.2	6	39.0	60
R6GD-X60	96,000	208/-23-60-1	187	253	29.3	134.0	1.2	7.6	46.8	70
	120,000	208/-23-60-1	187	253	29.3	134.0	1.2	7.6	46.8	70

Notes: FLA = Full Load Amps; LRA = Lock Rotor amps; RLA = Rated Load Amps.

Table 7. Electrical Data.

5. Multiply the gas flow rate in cubic feet per hour by the heating value of the gas in Btu per cubic foot to obtain the firing rate in Btu per hour. Example:
 - a. Time for one revolution of a gas meter with a one cubic foot dial = 40 seconds.
 - b. From **Table 8** read 90 cubic feet per hour of gas.
 - c. Heating value of the gas (obtained from gas supplier) = 1040 Btu per cubic foot.
 - d. Firing rate = $1040 \times 90 = 93,600$ Btu/h.
6. Adjustments to the firing rate can be made by adjusting the gas manifold pressure. See the High Altitude Application section for additional information of firing rate at elevations above 2000 ft.

The manifold pressure must be set to the appropriate value for your installation. Refer to either **Table 5** for natural gas or **Table 6** for LP/propane gas to verify the manifold pressure setting required for your particular installation. To adjust the manifold pressure, remove the regulator cap and turn the adjusting screw clockwise to increase pressure or counterclockwise to reduce pressure. Replace the regulator cap after adjustments are complete.

Verifying and Adjusting Temperature Rise — Verify that the temperature rise through the unit is within the range specified on the unit data label. Temperature rises outside the specified range could result in premature heat exchanger failure.

Place thermometers in the return and supply air stream as close to the duct connections as possible. The thermometer on the supply air side must be shielded from direct radiation from the heat exchanger to avoid false readings. Adjust all registers and duct dampers to the desired position and run the unit for ten to fifteen minutes before taking any temperature readings. The temperature rise is the difference between the supply and return air temperatures.

For typical duct systems, the temperature rise will fall within the range specified on the data label with the blower speed at the factory recommended setting (**see Table 3**). If the temperature rise measured is outside the range specified, it may be necessary to change the blower speed. Lower blower speeds will increase the temperature rise and higher blower speeds will decrease the temperature rise.

The unit is equipped with a multi-speed motor. A heating and cooling speed selection is made by moving the leads on the blower motor terminal block. The wiring diagram on the unit and in **Figure 10** show the speed taps for adjusting motor speed. Refer to the Blower Speed Section of this installation instruction for more details.

The integrated control is designed to start the circulating air blower 30 seconds after the gas valve is opened. The integrated control is factory wired to turn the blower motor

off 135 seconds after the gas valve is closed. (The heating blower off delay is factory set at 90 seconds. There is an additional 45 second off delay programmed into the X-13 blower motor for a total of 135 seconds)

Verifying Burner Operation — To verify operation of the burners remove the louvered control access panel to ensure there is power to the unit. Set the thermostat to a temperature above room temperature and observe the ignition sequence. The burner flame should carry over immediately between all burners. The flames should be blue, without yellow tips. Flames should extend from each burner without lifting off, curling, or floating. After verifying satisfactory flame characteristics, set the thermostat to a temperature below room temperature and verify that the burner flame extinguishes completely.



WARNING:

Uninsulated live components are exposed when louvered control access panel is removed.

Verify Operation of Over-Temperature Limit Control

— To verify operation of the over-temperature limit control, make sure that the louvered control access panel is in place and that there is power to the unit. Block the return airflow to the unit by installing a close-off plate in place of or upstream of the filter. Set the thermostat to a temperature above room temperature and verify the unit operates with the correct sequence of operation (see page 25). The over-temperature limit control should function to turn off the gas valve within approximately four minutes (the exact time depending on the efficiency of the close-off in blocking the return air to the unit). The circulating air and combustion blowers should continue to run when the over-temperature limit control switch opens. Remove the close-off immediately after the over-temperature limit control opens. If the unit operates for more than four minutes with no return air, set the thermostat to a temperature below room temperature, shut off the power to the unit, and replace the over-temperature limit control.

COMPONENT FUNCTIONS

Flame Sensor — The flame sensor acts to prove that flame has carried over from the ignitor to the right-most burner. If no flame is sensed, the unit will be shut down automatically.

Flame Roll-Out Control — The flame roll-out control acts to verify that the burner flame is being drawn into the heat exchanger tubes. If the burner flame is not being drawn into the heat exchanger tubes, the roll-out control will open within several seconds and the integrated control diagnostic light will flash one time. The circulating air blower and combustion blower will continue to operate if the flame roll-out control opens.

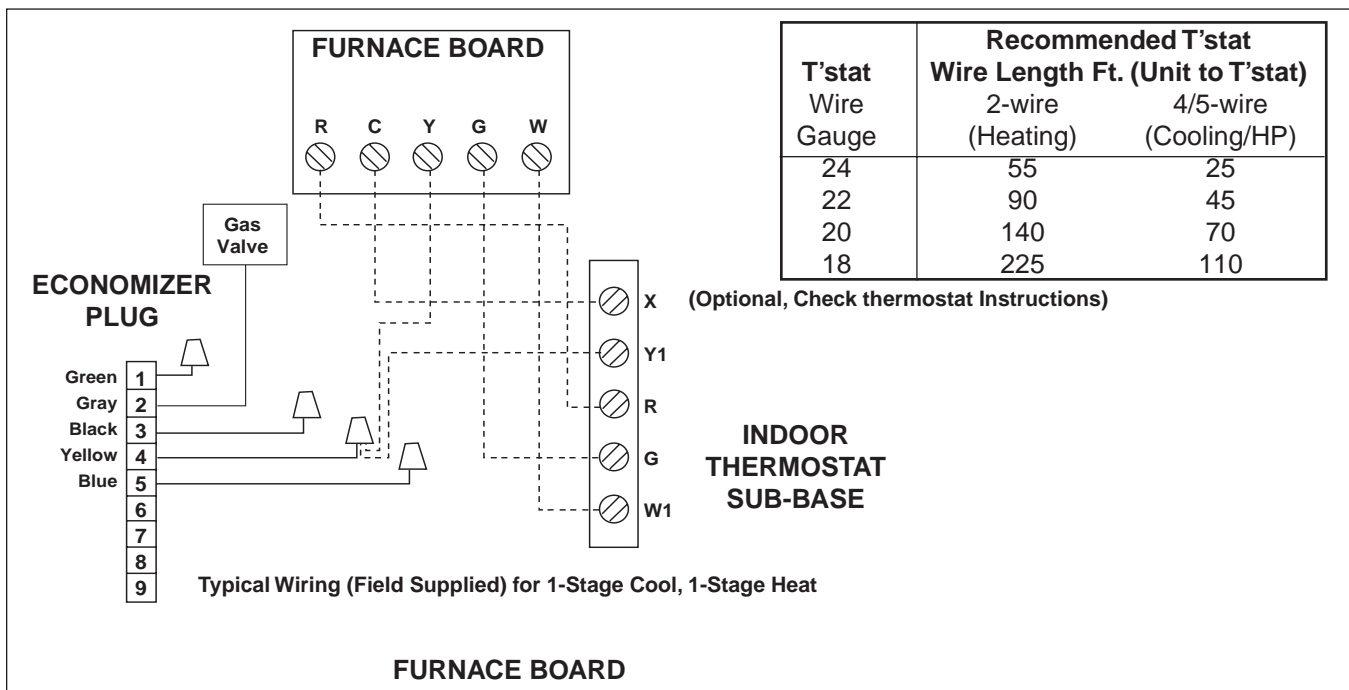

Figure 8. Typical Thermostat Connections.

Gas Valve — The gas valve acts to control the flow of gas to the burners. When the gas valve is energized it automatically opens and regulates the gas pressure in the manifold.

Pressure Switch — The pressure switch acts to verify that the inducer motor is drawing the combustion gases through the heat exchanger tubes and venting the gases through the vent system.

Over-Temperature Limit Control — The over-temperature limit control acts to prevent the air temperature leaving the unit from exceeding the maximum outlet air temperature. If the limit opens, the integrated control diagnostic will flash one time. The circulating air blower and combustion blower will continue to operate if the over-temperature limit control opens.

UNIT MAINTENANCE

⚠ WARNING:

To avoid risk of electrical shock, personal injury, or death, disconnect all electrical power to the unit before performing any maintenance or service. The unit may have more than one electrical supply.

⚠ CAUTION:

Use care when removing parts from this unit. Personal injury can result from sharp metal edges present in all equipment of sheet metal construction.

Refrigerant Charging — The packaged gas/electric units are fully charged at the factory with R410A refrigerant. The system refrigerant charge can be checked and adjusted through the external service ports provided. Use only gauge lines which have a “Schraeder” depression device present to actuate the valve. Refrigerant charging must be done by qualified personnel familiar with safe and environmentally responsible refrigerant handling procedures.

⚠ WARNING:

The gas/electric units are shipped fully charged and ready for installation. When a system is installed according to these instructions, no refrigerant charging is required. If repairs make it necessary for evacuation and charging, it should only be done by qualified, trained personnel thoroughly familiar with this equipment. Some local codes require licensed installation/service personnel to service this type of equipment. Under no circumstances should the owner attempt to install and/or service this equipment. Failure to comply with this warning could result in property damage, personal injury, or death.

Routine Maintenance — Proper maintenance is important to achieve optimum performance from the air conditioner. The ability to properly perform maintenance on this equipment requires certain mechanical skills and tools. If you do not possess these skills, contact your dealer for maintenance. Consult your local dealer about the availability of maintenance contracts. At a minimum, routine maintenance should include the following:

Packaged Single Stage Gas Heat/Electric Air Conditioner 208/230 Volt Single Phase 60Hz

- NOTES:**
1. Disconnect all power before servicing.
 2. For supply connections use copper conductors only.
 3. Not suitable on systems that exceed 150V to ground.
 4. If any of the original wire as supplied with the furnace must be replaced, it must be replaced with wiring material having a temperature rating of at least 105 C.
 5. For supply wire ampacities and overcurrent protection, see unit rating plate.
1. Couper le courant avantaire letretien.
 2. Employez uniquement des conducteurs en cuivre.
 9. Ne convient pas aux installations de plus de 150V a la terre.

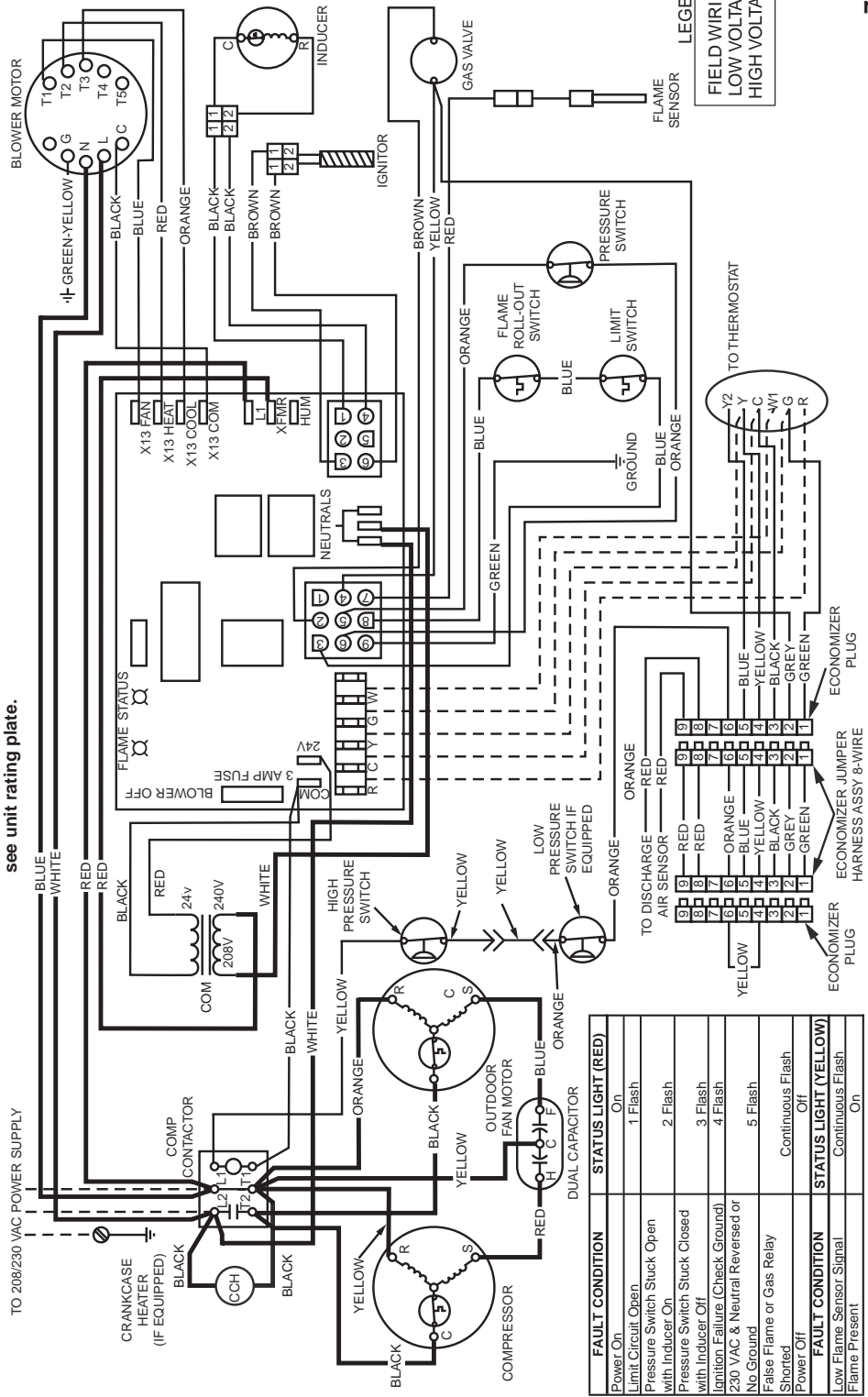

FAULT CONDITION	STATUS LIGHT (RED)
Power On	On
Limit Circuit Open	1 Flash
Pressure Switch Stuck Open with Inducer On	2 Flash
Pressure Switch Stuck Closed with Inducer Off	3 Flash
Ignition Failure (Check Ground)	4 Flash
230 VAC & Neutral Reversed or No Ground	5 Flash
False Flame or Gas Relay Shorted	Continuous Flash
Power Off	Off
FAULT CONDITION	STATUS LIGHT (YELLOW)
Low Flame Sensor Signal	Continuous Flash
Flame Present	On

7107850

Figure 10. Single-Phase Wiring Diagram.

Air Filter — Inspect and clean or replace the air filter every three to four weeks.

 **WARNING:**

Never operate the unit without a filter in place. Dust and lint in the return air can build up on internal components, resulting in loss of efficiency, equipment damage, and possible fire risk.

Vent Cover Assembly — Inspect and clean the screen of the vent cover assembly at the beginning of each heating and cooling seasons.

Condensate Drain and Outdoor Coil — Inspect the condensate drain and outdoor coil at the beginning of each cooling season. Remove any debris. Clean the outdoor coil and hail guard louvers (optional) as necessary using a mild detergent and water. Rinse thoroughly with water.

Electrical — Inspect the electrical connections for tightness at the beginning of each heating and cooling season. Service as necessary.

 **CAUTION:**

Label all wires prior to disconnection when servicing controls. Wiring errors can cause improper and dangerous operation.

Motor Lubrication — The motors for the circulating air blower, outdoor fan, and combustion blower are pre-lubricated at the factory. No further oiling is required for the life of this product.

 **WARNING:**

Lubrication of the motors in this unit is not required. Do not lubricate any motor in this product.

Blower Compartment — The blower compartment should be cleaned monthly during the heating and cooling seasons to remove any dirt and lint that may have accumulated in the compartment or on the blower and motor. Buildup of dirt and lint on the blower and motor can create excessive loads on the motor resulting in higher than normal operating temperatures and possible shortened service life.

Heat Exchanger and Burner Maintenance — The unit should operate for many years without excessive scale buildup in the heat exchanger, however, the heat exchanger, the vent system, and the burners should be inspected and cleaned (if required) by a qualified serviceman annually to ensure continued safe operation. Particular attention must be given to identify deterioration from corrosion or other sources.

 **WARNING:**

Holes in the heat exchanger can cause products of combustion to enter the home. Replace the heat exchanger if leaks are found. Failure to prevent products of combustion from being circulated into the living space can create potentially hazardous conditions including carbon monoxide poisoning that could result in personal injury or death.

Cleaning of Heat Exchanger — If the heat exchanger must be cleaned due to soot or scale build up, follow the steps below.

1. Shut off the gas supply to the unit either at the meter or at the manual valve in the gas supply piping.
2. Turn off all power to the unit and set the thermostat to the lowest temperature setting.
3. Remove the louvered control access panel from the unit.
4. Turn the gas control switch on the gas valve to the "OFF" position.
5. Disconnect the wires from the gas valve, ignitor, flame sensor, combustion air motor, flame roll-out control, over-temperature limit switch, and pressure switch.
6. Remove the silicone rubber tube from the collector pan to the pressure switch.
7. Remove the four nuts that hold the combustion blower to the collector pan and remove the complete combustion blower.
8. Remove the screws that hold the collector pan in place, and remove the collector pan from the unit.
9. Using wrenches, separate the ground-joint union in the gas supply piping at the unit.
10. Remove the piping between the gas valve and the ground-joint union, if necessary.
11. Remove the screws that hold the burner assembly in place and remove the burner assembly. **BE EXTREMELY CAREFUL NOT TO DAMAGE THE IGNITOR WHILE REMOVING THE BURNER ASSEMBLY.**
12. The unit heat exchanger tubes can now be cleaned by the use of a round wire brush attached to a length of high grade stainless steel cable, such as drain

FOR YOUR SAFETY READ BEFORE OPERATING

WARNING: If you do not follow these instructions exactly, a fire or explosion may result causing property damage, personal injury, or loss of life.

- A. This appliance does not have a pilot. It is equipped with an ignition device which automatically lights the burner. Do not try to light the burner by hand.
- B. BEFORE OPERATING smell all around the appliance area for gas. Be sure to smell next to the floor because some gas is heavier than air and will settle on the floor.
- WHAT TO DO IF YOU SMELL GAS
- Do not try to light any appliance.
 - Do not touch any electrical switch; do not use any phone in your building.
 - Immediately call your gas supplier from a neighbor's phone. Follow the gas supplier's instructions.
 - If you cannot reach your gas supplier, call the fire department.
- C. Use only your hand to push in or turn the gas control knob. Never use tools. If the knob will not push in or move by hand, do not try to repair it, call a qualified service technician. Force or attempted repair may result in a fire or explosion.
- D. Do not use this appliance if any part has been under water. Immediately call a qualified service technician to inspect the appliance and to replace any part of the control system and any gas control which has been under water.

POUR VOTRE SÉCURITÉ. À LIRE AVANT L'EMPLOI

ATTENTION! L'inobservation de ces instructions peut entraîner un incendie ou une explosion pouvant causer des dommages à votre propriété à votre personne, ou la mort.

- A. Cet appareil ménager n'a pas de veilleuse. Il est doté d'un système d'allumage automatique. Ne pas essayer d'allumer le brûleur manuellement.
- B. AVANT L'USAGE. Attention à une possible odeur de gaz surtout au niveau du plancher où les gaz les plus lourds ont la tendance de se concentrer.
- EN CAS D'ODEUR DE GAZ.
- Ne mettre en marche aucun appareil électrique.
 - Ne toucher à aucun commutateur électrique, ne pas employer le téléphone.
 - Quitter le bâtiment immédiatement et avertir la compagnie du gaz en utilisant le téléphone d'un voisin.
 - A défaut de la compagnie du gaz, avertir le service des pompiers.
- C. Enfoncer ou faire tourner le robinet à gaz à la main seulement. Ne jamais utiliser d'outils. S'il n'est pas possible de faire tourner ou d'enfoncer le robinet à la main, ne pas essayer de le réparer. Faire appel à un spécialiste. Forcer ou tenter de réparer le robinet pourrait être à l'origine d'une explosion ou d'un incendie.
- D. Il est déconseillé d'utiliser cet appareil en contact prolongé avec l'eau. Faire inspecter ou remplacer toute commande par un technicien qualifié si un des systèmes de contrôle du gaz s'est trouvé sous l'eau.

OPERATING INSTRUCTIONS

1. **STOP!** Read the safety information above on this label.
2. Set the thermostat to the lowest setting.
3. Turn off all electrical power to the appliance.
4. The appliance's ignition device automatically lights the burner. Do not try to light burner by hand.
5. Remove the control access door/panel (upper door if two-door model).
6. Move the gas control switch to the "OFF" position. (See Figure 1)
7. Wait five (5) minutes to clear out any gas. Then smell for gas, including near the floor. If you smell gas, STOP! Follow "B" in above information. If you don't smell gas, go to the next step.
8. Move the gas control switch to the "ON" position. (See Figure 1)
9. Replace the control access door/panel (upper door if two-door model).
10. Turn on all electrical power to the appliance.
11. Turn the thermostat to a desired setting.
12. If the appliance will not operate, follow the instructions "To Turn Off Gas To Appliance" and call your service technician or gas supplier.

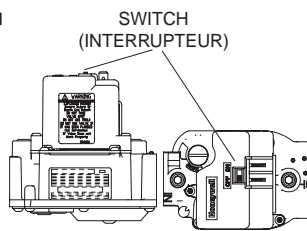

Figure 1

MODE D'EMPLOI

1. **ATTENTION!** Lire d'abord la liste des mesures de sécurité ci-dessus.
2. Mettre le thermostat à la position minimale.
3. Couper le courant électrique qui mène à l'appareil.
4. Cet appareil ménager étant doté d'un système d'allumage automatique, ne pas essayer d'allumer le brûleur manuellement.
5. Retirer le panneau/volet d'accès de commande (panneau supérieur s'il s'agit d'un modèle à deux panneaux).
6. Réglez l'interrupteur de commande du gaz à la position "OFF". (voir Figure 1).
7. Attendre cinq (5) minutes pour s'assurer de la dissipation du gaz. En cas d'odeur, ARRÊTER LE PROCÉDÉ. Suivre les instructions ci-dessus (Section B). En l'absence de toute odeur de gaz, avancer à l'étape suivante.
8. Réglez l'interrupteur de commande du gaz à la position "ON". (voir Figure 1).
9. Remettre le panneau/volet d'accès de commande en place (panneau supérieur s'il s'agit d'un modèle à deux panneaux).
10. Rebrancher l'appareil sur le réseau électrique.
11. Ajuster le thermostat à la position désirée.
12. Si l'appareil ne fonctionne pas, suivre les "Directives d'arrêt" cidessous et appeler le technicien de service.

TO TURN OFF GAS TO APPLIANCE

1. Set the thermostat to the lowest setting.
2. Turn off all electrical power to the appliance if service is to be performed.
3. Remove the control access door/panel (upper door if two-door model).
4. Move the gas control switch to the "OFF" position. Do not use force. (See Figure 1)
5. Replace the control access door/panel (upper door if two-door model).

DIRECTIVES D'ARRÊT

1. Mettre le thermostat à la position minimale.
2. Débrancher l'appareil en prévision de la réparation.
3. Retirer le panneau/volet d'accès de commande (panneau supérieur s'il s'agit d'un modèle à deux panneaux).
4. Réglez l'interrupteur de commande du gaz à la position "OFF". Ne forcez pas. (voir Figure 1).
5. Remettre le panneau/volet d'accès de commande en place (panneau supérieur s'il s'agit d'un modèle à deux panneaux).

cleanout cable. Attach variable speed reversible drill to the other end of the spring cable. Slowly rotate the cable with the drill and insert it into the top portion of the heat exchanger. While reversing the drill, work the cable in and out several times to obtain sufficient cleaning. Repeat this sequence for each heat exchanger tube.

13. When all heat exchanger tubes have been cleaned, any debris inside the tubes can be removed with the nozzle of a vacuum cleaner.
14. With a light, check the condition of the upper and lower sections of the heat exchanger tube.
15. Inspect the burners and clean them (if necessary) with a soft wire brush and/or the nozzle of a vacuum cleaner. **BE EXTREMELY CAREFUL NOT TO DAMAGE THE IGNITOR WHILE CLEANING THE BURNER.**
16. Replace all the parts in reverse order from which they were removed.

17. Follow the operating instructions found on the right side door and the User's Information Manual to return the unit to operation.

Cleaning of Burners — If the burners must be cleaned, follow the steps below.

1. Shut off the gas supply to the unit either at the meter or at a manual valve in the supply piping.
2. Turn off all power to the unit and set the thermostat to the lowest temperature setting.
3. Remove the louvered control access panel from the unit.
4. Turn the gas control switch to the "OFF" position.
5. Disconnect the wires from the gas valve, ignitor, and flame sensor.
6. Using wrenches, separate the ground-joint union in the gas supply piping at the unit.

GAS FLOW RATE (CUBIC FEET PER HOUR)							
TIME FOR ONE REVOLUTION (SECONDS)	CUBIC FEET PER REVOLUTION OF METER			TIME FOR ONE REVOLUTION (SECONDS)	CUBIC FEET PER REVOLUTION OF METER		
	1	5	10		1	5	10
10	360	1800	3600	66	55	273	545
12	300	1500	3000	68	53	265	529
14	257	1286	2571	70	51	257	514
16	225	1125	2250	72	50	250	500
18	200	1000	2000	74	49	243	486
20	0	900	1800	76	47	237	474
22	164	818	1636	78	46	231	462
24	150	750	1500	80	45	225	450
26	138	692	1385	82	44	220	439
28	129	643	1286	84	43	214	429
30	120	600	1200	86	42	209	419
32	113	563	1125	88	41	205	409
34	106	529	1059	90	40	200	400
36	100	500	1000	92	39	196	391
38	95	474	947	94	38	191	383
40	90	450	900	96	38	188	375
42	86	429	857	98	37	184	367
44	82	409	818	100	36	180	360
46	78	391	783	102	35	176	353
48	75	375	750	104	35	173	346
50	72	360	720	106	34	170	340
52	69	346	692	108	33	167	333
54	67	333	667	110	33	164	327
56	64	321	643	112	32	161	321
58	62	310	621	114	32	158	316
60	60	300	600	116	31	155	310
62	58	290	581	118	31	153	305
64	56	281	563	120	30	150	300

Table 8. Gas Flow Rate (Cubic Feet Per Hour).

7. Remove the piping between the gas valve and the ground-joint union, if necessary.
 8. Remove the screws that hold the burner assembly in place and remove the burner assembly. **BE EXTREMELY CAREFUL NOT TO DAMAGE THE IGNITOR WHILE REMOVING THE BURNER ASSEMBLY.**
 9. Inspect the burners and clean them (if necessary) with a soft wire brush and/or the nozzle of a vacuum cleaner. **BE EXTREMELY CAREFUL NOT TO DAMAGE THE IGNITOR WHILE CLEANING THE BURNER.**
 10. Replace all the parts in reverse order from which they were removed.
 11. Follow the lighting instructions found on the lower unit door to return the unit to operation.
3. If a call for heat occurs, the circulating blower de-energizes prior to normal heating cycle.

Heating Mode:

1. On a call for heat the thermostat closes, applying 24 VAC to the W terminal on the control board.
2. The control board checks for continuity on the 24 VAC limit control circuit (over-temperature limit switch, flame rollout switches and blocked vent switch in series). If an open limit is detected the control board will energize the inducer blower. All other system functions will be inoperable until the limit circuit closes. While the limit is open, the red LED will pulse at a rate of 1 blink per unit time.
3. The furnace control checks for continuity across the pressure switch (24 VAC). If the pressure switch is closed the heat mode sequence will not continue. If it remains closed for 10 seconds the red LED will blink 3 times repetitively until the fault condition clears.
4. If the pressure switch is open, the inducer is energized.
5. The inducer will pre-purge for 30 seconds and then the igniter will start its warm-up as follows:
Initial Power up: After 30 seconds of igniter warm-up the gas valves (24 VAC) will then open. The igniter circuit will stay energized for 3 seconds after the gas valve opens.

After Initial Power up: The control has a programmed adaptive ignition feature which varies the warm-up period as follows: If ignition is successful the warm-up is reduced by 3-seconds on each subsequent call for heat until ignition failure occurs. Upon ignition failure, the warm-up is increased by 3-seconds on the next try. If successful, the timing remains fixed at this level. In general, whenever ignition failure occurs the warm-up interval is increased by 3-seconds on the next try. And if successful, it remains there. Min. and max. warm-up time limits are set at 6 and 54-seconds, respectively.

6. The furnace control must prove flame via the flame sensor 5 seconds after the gas valves open. If flame is sensed, burners are on and the igniter cools off. If no flame is sensed, the gas valve closes immediately and the inducer continues to run. A second trial for ignition (step 6) begins. If no flame is sensed on the fifth try for ignition, the furnace control is locked and the red LED will blink 4 times repetitively. The thermostat must be opened for at least ten seconds to reset the furnace control after a lock out. Otherwise, the furnace will attempt another ignition sequence in 1 hour.



CAUTION:

Verify proper operation after servicing.

Operating Sequence

The operating sequences for the heating, cooling, and fan modes are described below. Refer to the wiring diagram for the unit (**Figure 10**).

Cooling Mode:

1. On a call for cooling the thermostat closes, applying 24 VAC to the green and yellow leads in the low voltage area.
2. The green lead applies 24VAC to the "G" terminal of the integrated control energizing the main circulating blower circuit at the cooling speed.
3. The yellow lead applies 24VAC to the contactor.
4. When the thermostat is satisfied the contactor and integrated control are de-energized.
5. The circulating blower motor is de-energized after a 90-second delay.

Blower Mode:

1. On a call for fan only operation, the thermostat applies 24 VAC to the green lead connected to the "G" terminal of the integrated control.
2. The circulating blower is energized immediately at the heating speed if "2-SPD" is selected on the control or the fan only speed if "3-SPD" is selected.

7. 30 seconds from the gas valve opening the main blower starts and continues to run.
8. When the thermostat is satisfied, the "W" terminal on the integrated control is de-energized.
9. The gas valve circuit is de-energized and the gas valve closes.
10. The inducer motor will continue to run for the post purge period of 25 seconds.
11. The main blower will continue to run for the blower off delay of 135 seconds.
12. After the "blower off" timer has been satisfied, the integrated control de-energizes the main circulating blower circuit.

FAULT CONDITION	STATUS LIGHT (RED)
Power On Limit Circuit Open Pressure Switch Stuck Open Pressure Switch Stuck Closed Ignition Failure (Check Ground) 230 VAC & Neutral Reversed or No Ground False Flame or Gas Relay Shorted Power Off	On 1 Flash 2 Flash 3 Flash 4 Flash 5 Flash Continuous Flash Off
FAULT CONDITION	STATUS LIGHT (YELLOW)
Low Flame Sensor Signal Flame Present	Continuous Flash On

Table 9. Diagnostic Codes.

Unit Fails to Operate

If the unit does not operate in the cooling mode, be certain to check the following:

1. The thermostat is operating properly.
2. Electrical power to the unit is turned on.
3. The filters are not dirty.
4. The service doors are in place.
5. The 3 amp fuse is operational.
6. The anti-short cycle timer's 5-minute cycle has finished for single phase units.

If the unit does not operate in the heating mode, be certain to check the following:

1. The thermostat is operating properly.
2. Electrical power to the unit is turned on.
3. The filters are not dirty.
4. The gas is turned on.
5. The manual shut-off valve is open.
6. The service doors are in place.
7. The flame roll-out control is closed.
8. Refer to the diagnostic code table on the wiring diagram or see **Table 9**.
9. The 5 amp fuse is operational.

R6GD-X24 Charging Chart - Cooling

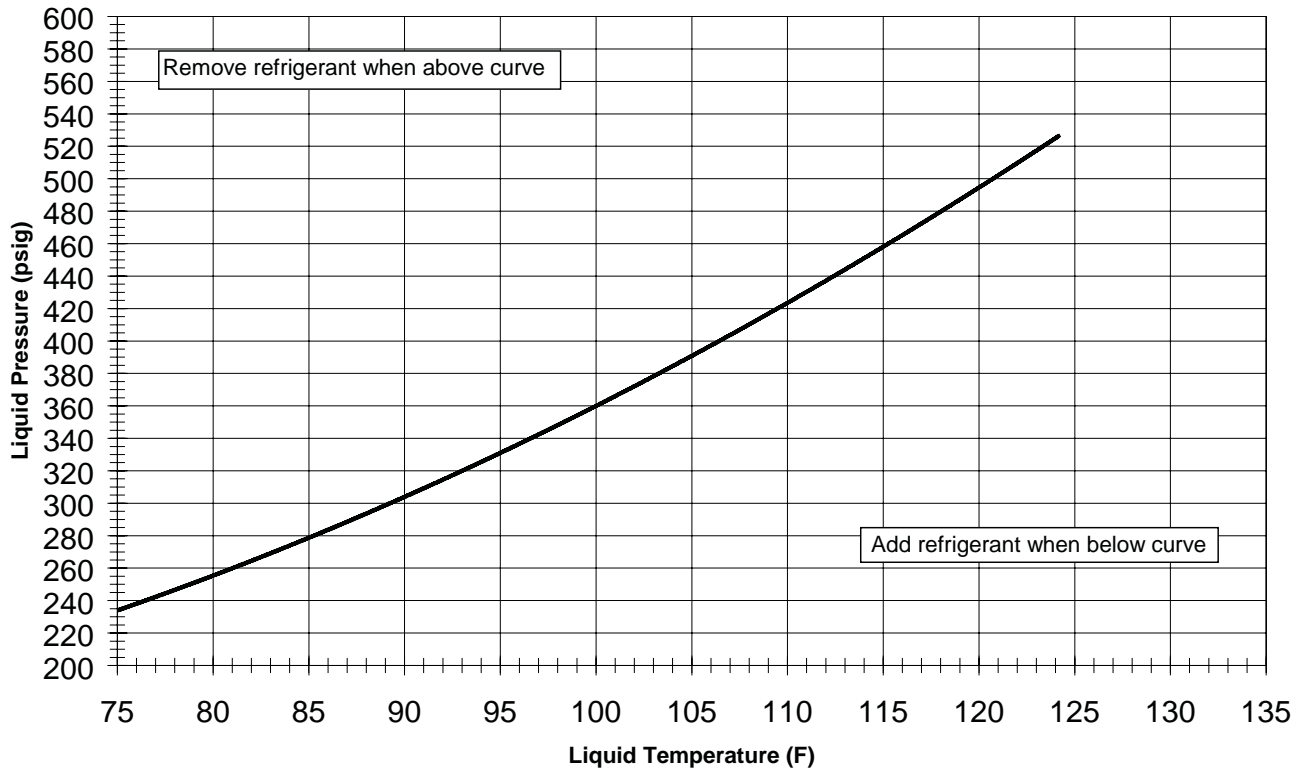

R6GD-X30 Charging Chart - Cooling

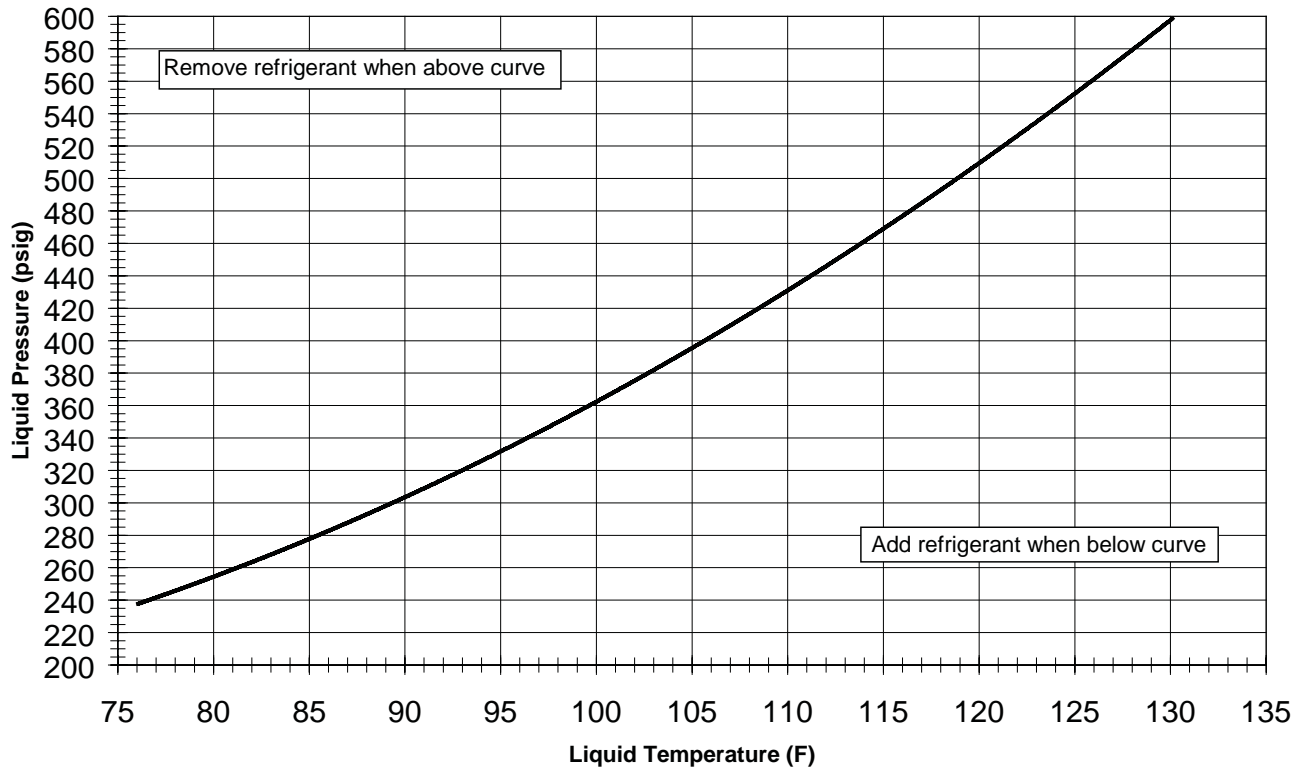

R6GD-X36 Charging Chart - Cooling

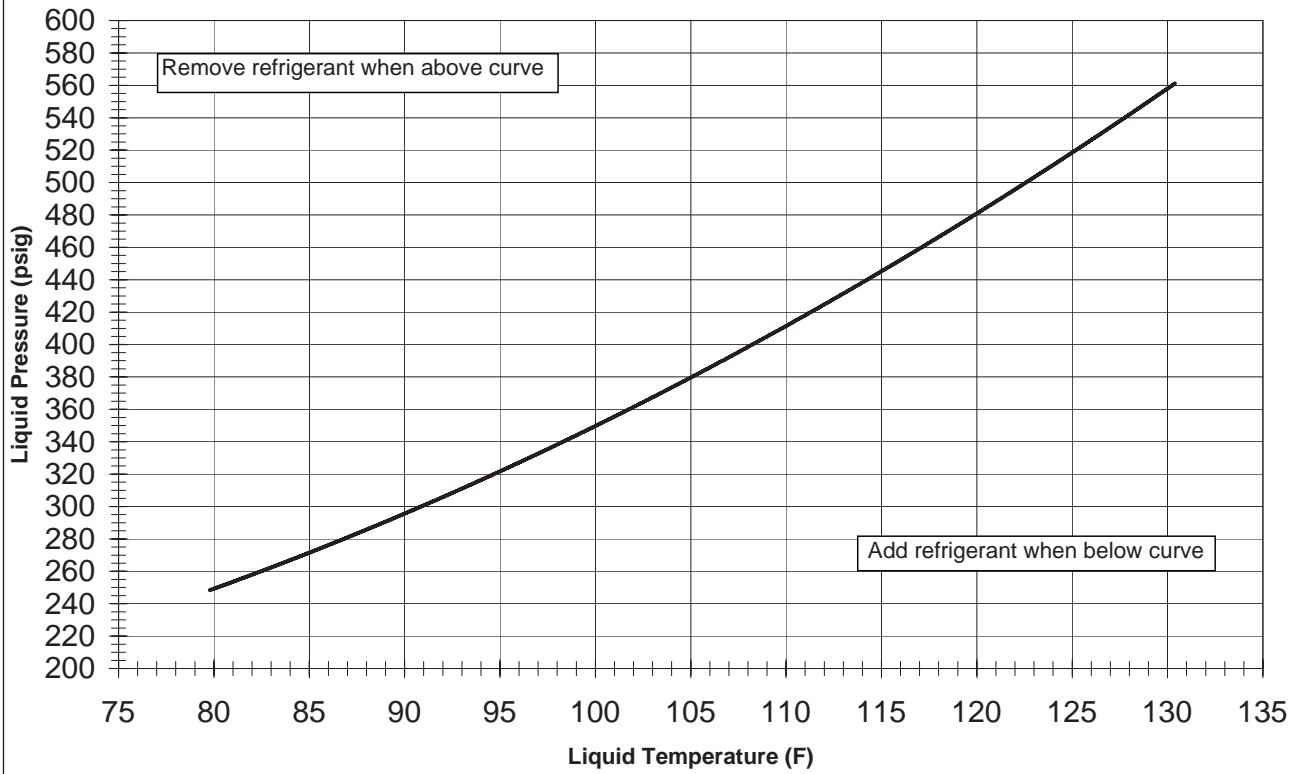

R6GD-X42 Charging Chart - Cooling

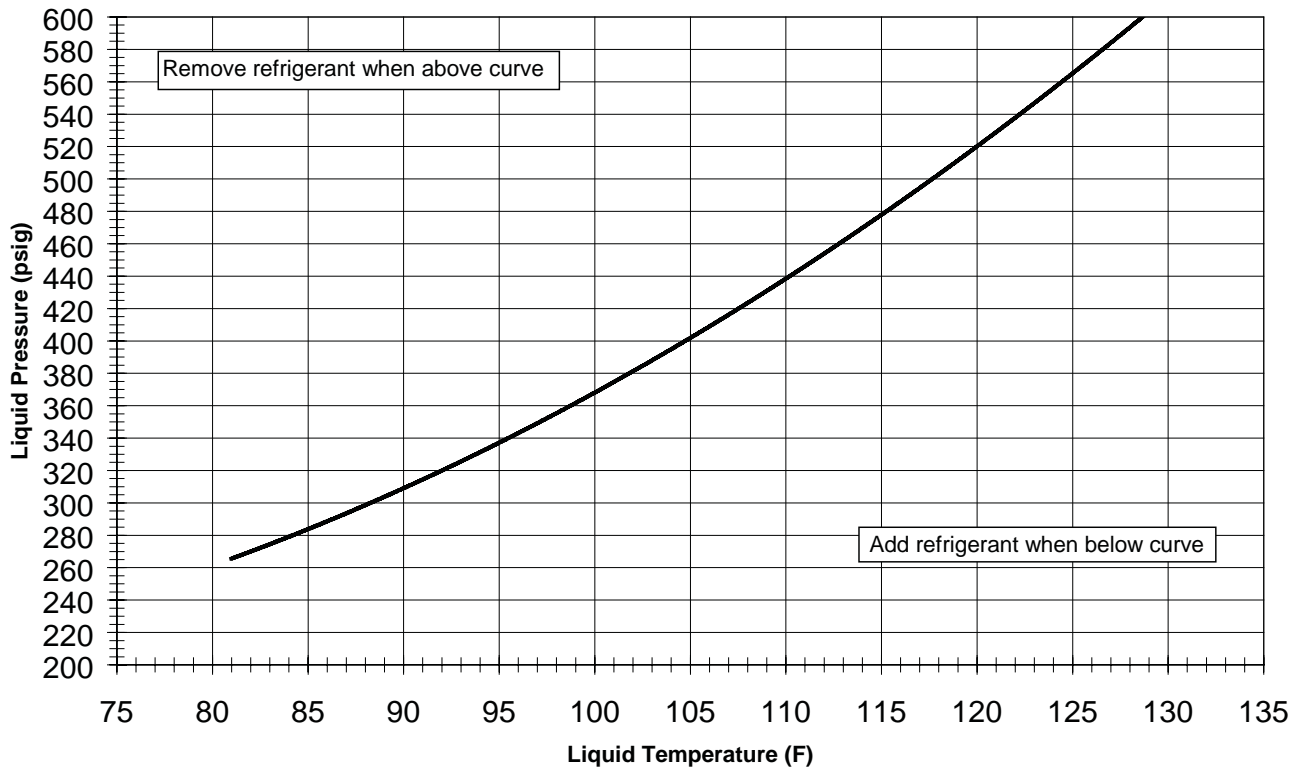

R6GD-X48 Charging Chart - Cooling

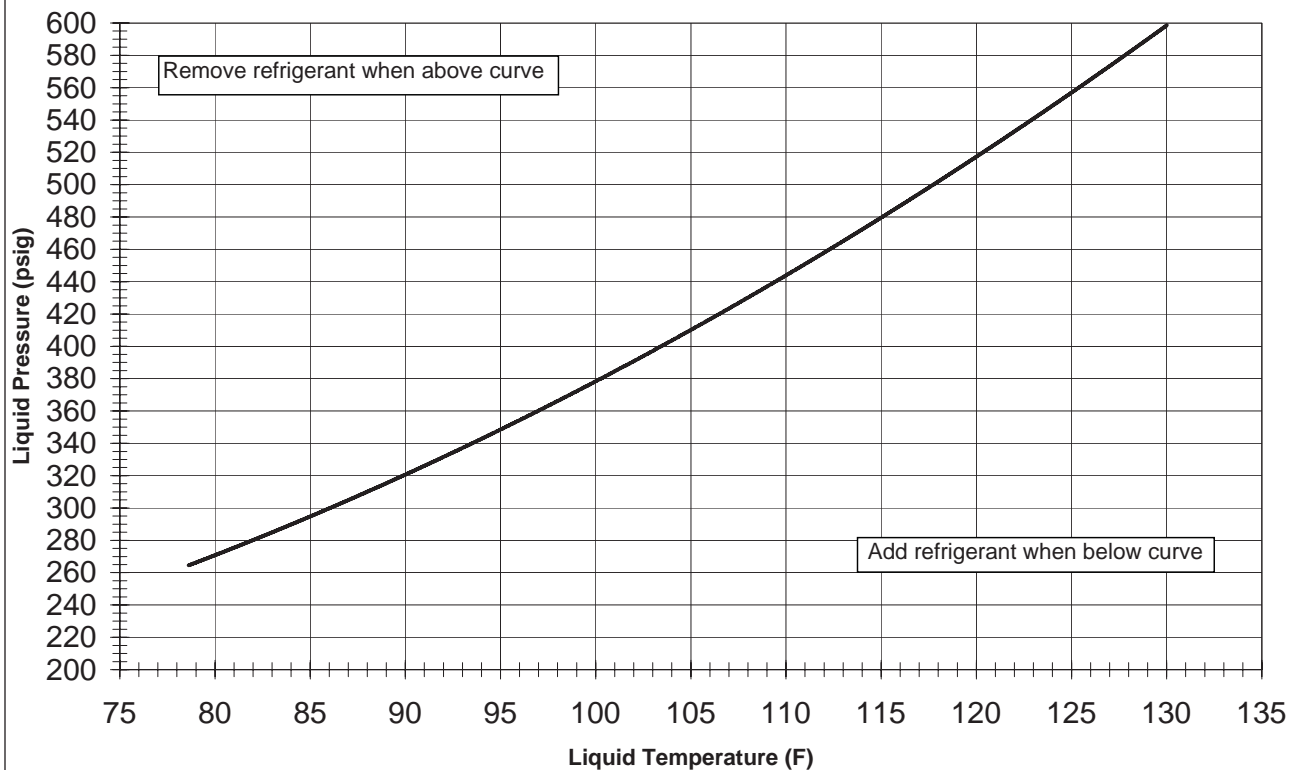

R6GD-X60 Charging Chart - Cooling

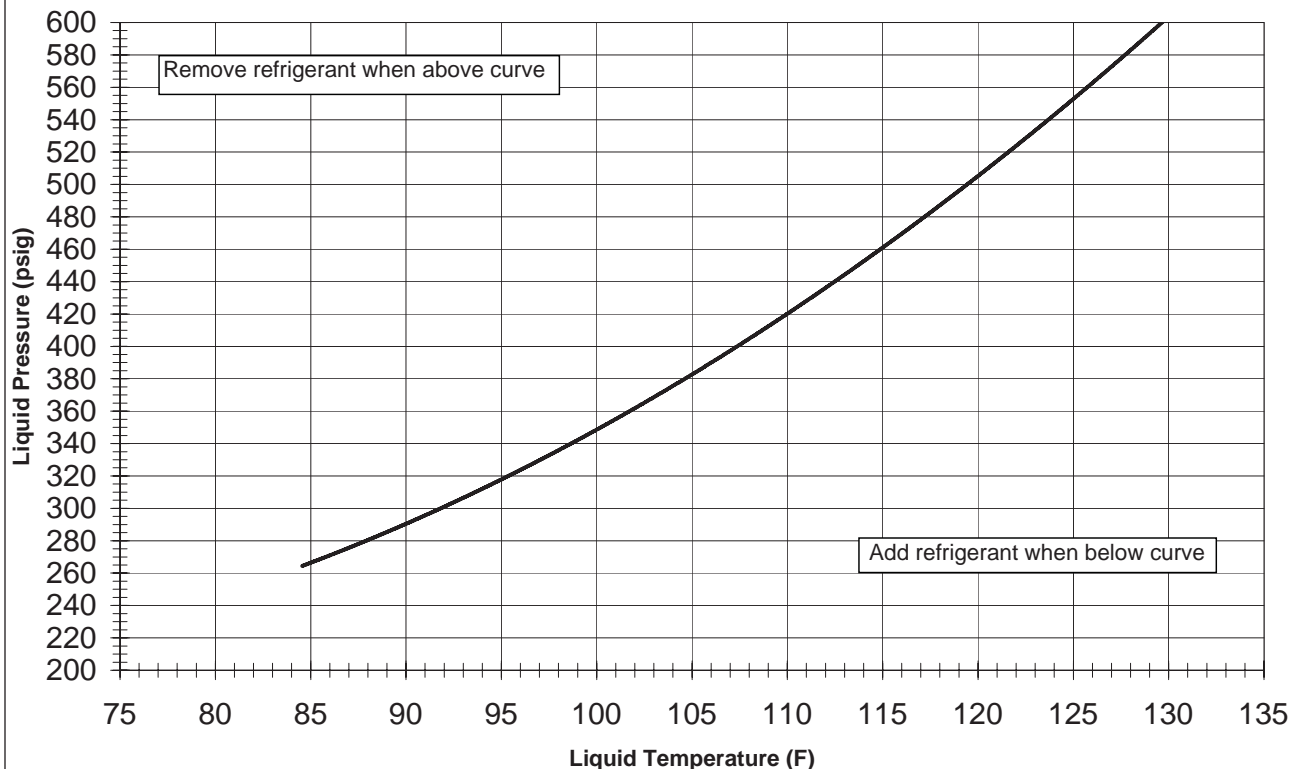

INSTALLATION/PERFORMANCE CHECK LIST

LOCATION _____ CITY _____ STATE _____

INSTALLER _____ CITY _____ STATE _____

UNIT MODEL NUMBER _____ UNIT SERIAL NUMBER _____

Minimum Clearances per Table 1? _____ Is there Proper Draft? _____

Electrical Connections tight? _____ Is vent hood free from restrictions? _____

Supply Voltage: _____ Volts Is the Filter(s) clean? _____

Blower Motor H.P.: _____

Has the Thermostat been calibrated? _____

FUEL TYPE: Is the Thermostat level? _____

Natural Gas _____ LP/Propane _____ Is the Heat Anticipator Setting correct? _____

Gas Piping Connections leak-tested? _____

Gas Line Pressure: _____ Has the Owner's Information been reviewed with the

(in. water column, with furnace operating) homeowner? _____

Manifold Pressure: _____

(in. water column, with furnace operating) Has the Literature Package been left with the

Is there adequate fresh air supply for combustion and homeowner? _____

ventilation? _____

Furnace Input: _____ Btu/hr)

Supply Air Temperature: _____ (°F)

Return Air Temperature: _____ (°F)

Temperature Rise: _____ (°F)

Is the vent hood installed? _____

**INSTALLER: PLEASE LEAVE
THESE INSTALLATION
INSTRUCTIONS WITH THE
HOMEOWNER.**

