

4 ROOF EDGE DETAIL @ EI&FS
Scale: 1 1/2" = 1'-0"

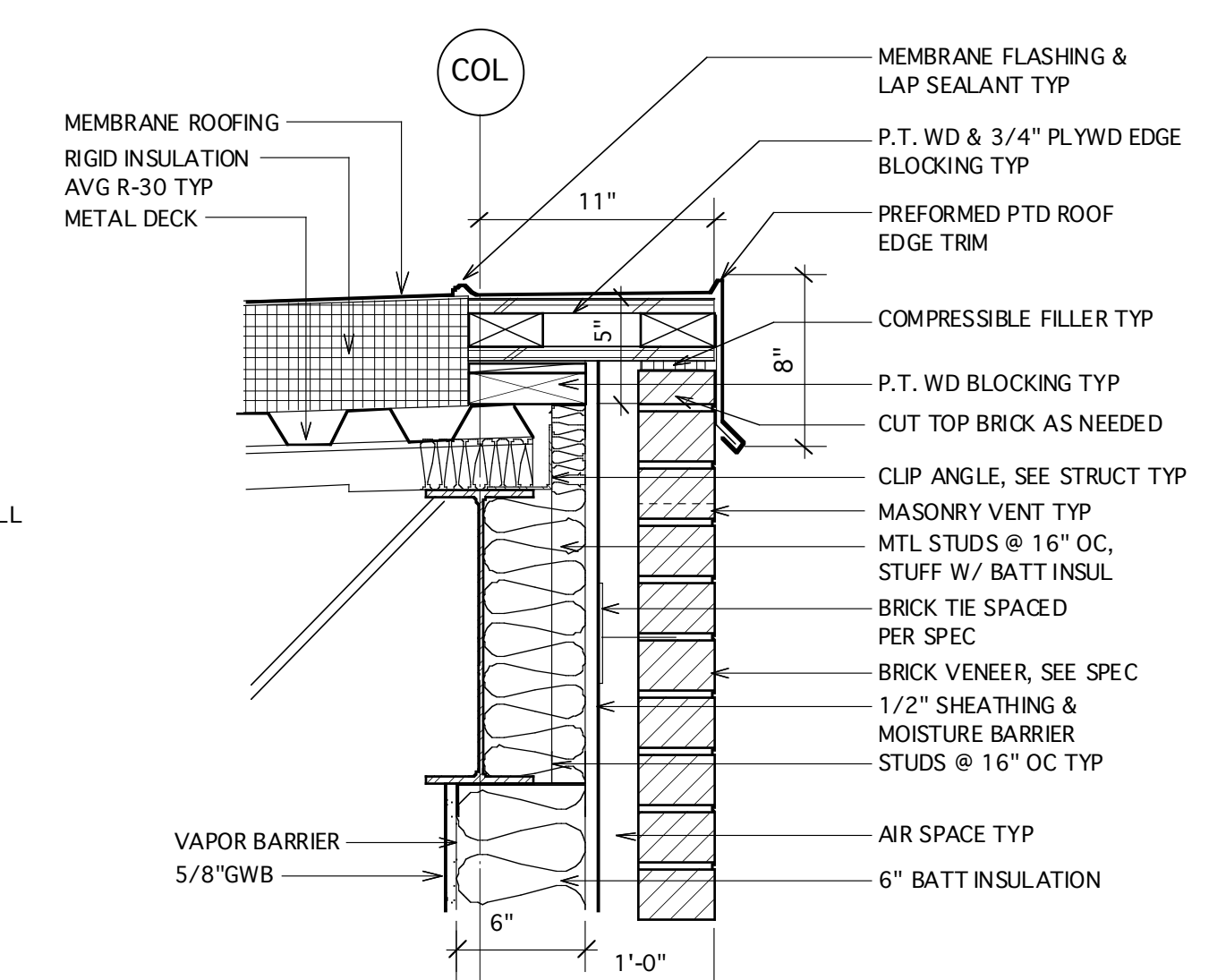

3 TYPICAL ROOF EDGE DETAIL
Scale: 1 1/2" = 1'-0"

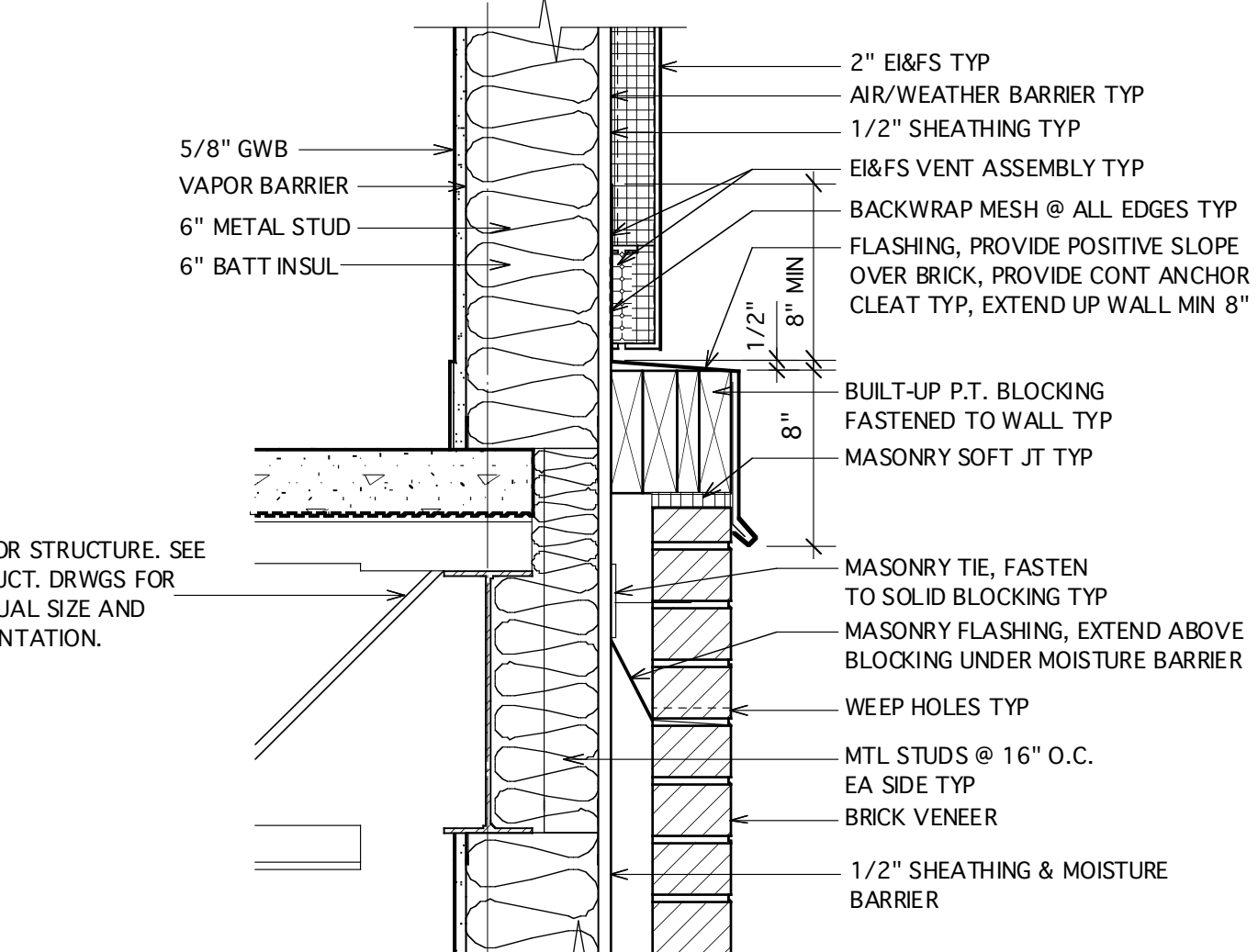

2 BRICK TO EI&FS SIDING TRANSITION TYP
Scale: 1 1/2" = 1'-0"

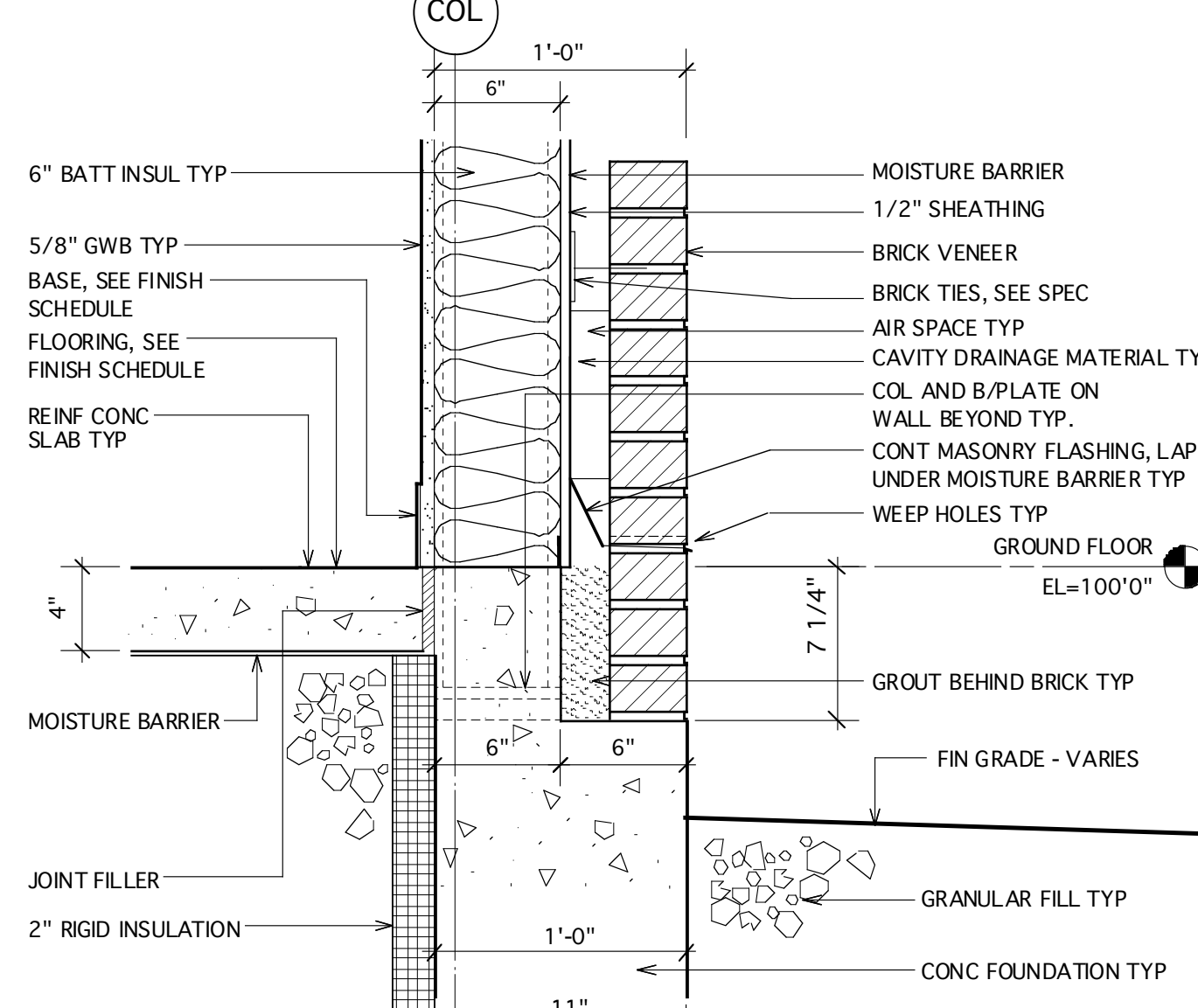

1 BOTTOM OF WALL DETAIL TYPICAL
Scale: 1 1/2" = 1'-0"

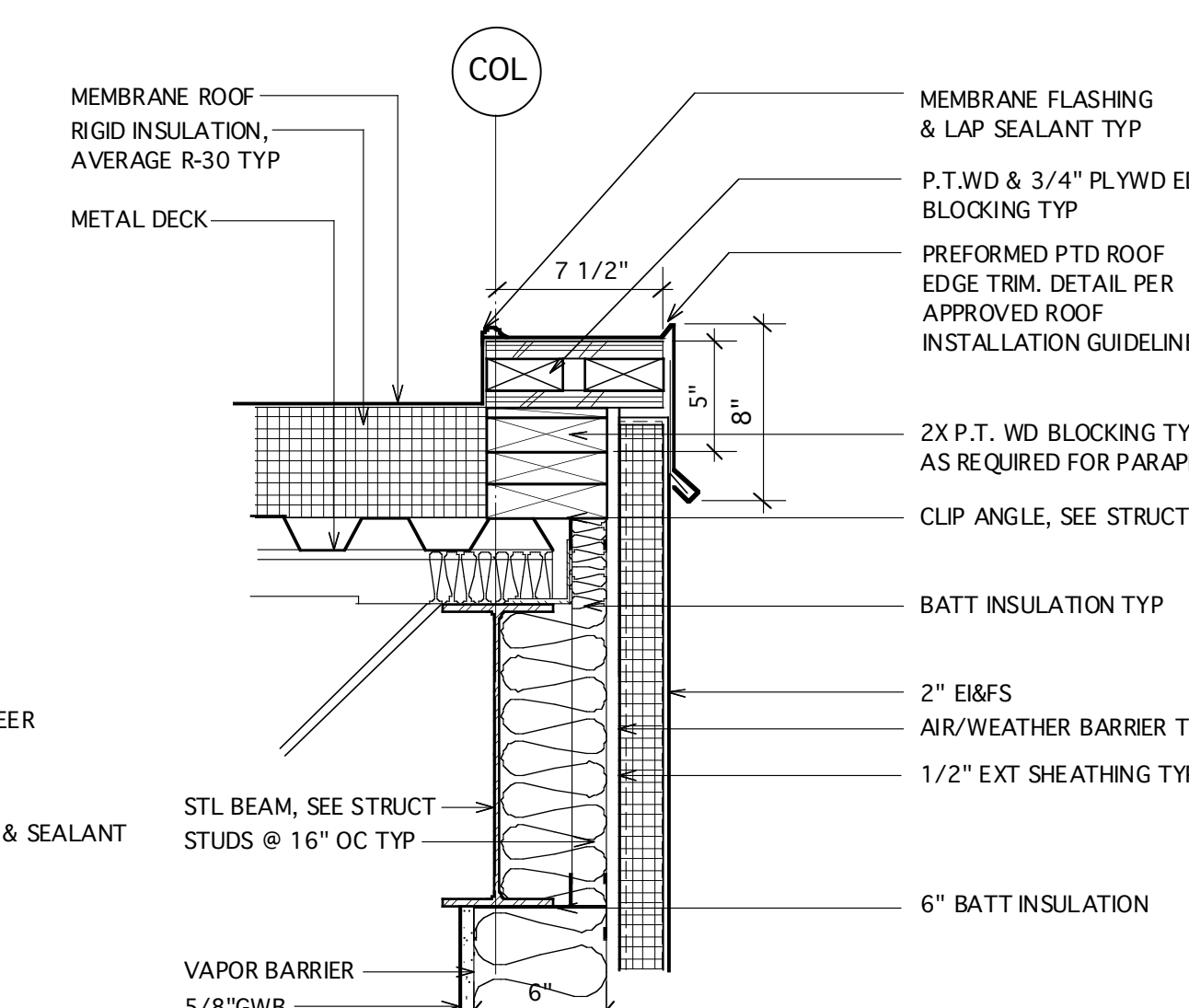

5 ROOF EDGE DETAIL @ PARAPET - HEIGHT VARIES
Scale: 1 1/2" = 1'-0"

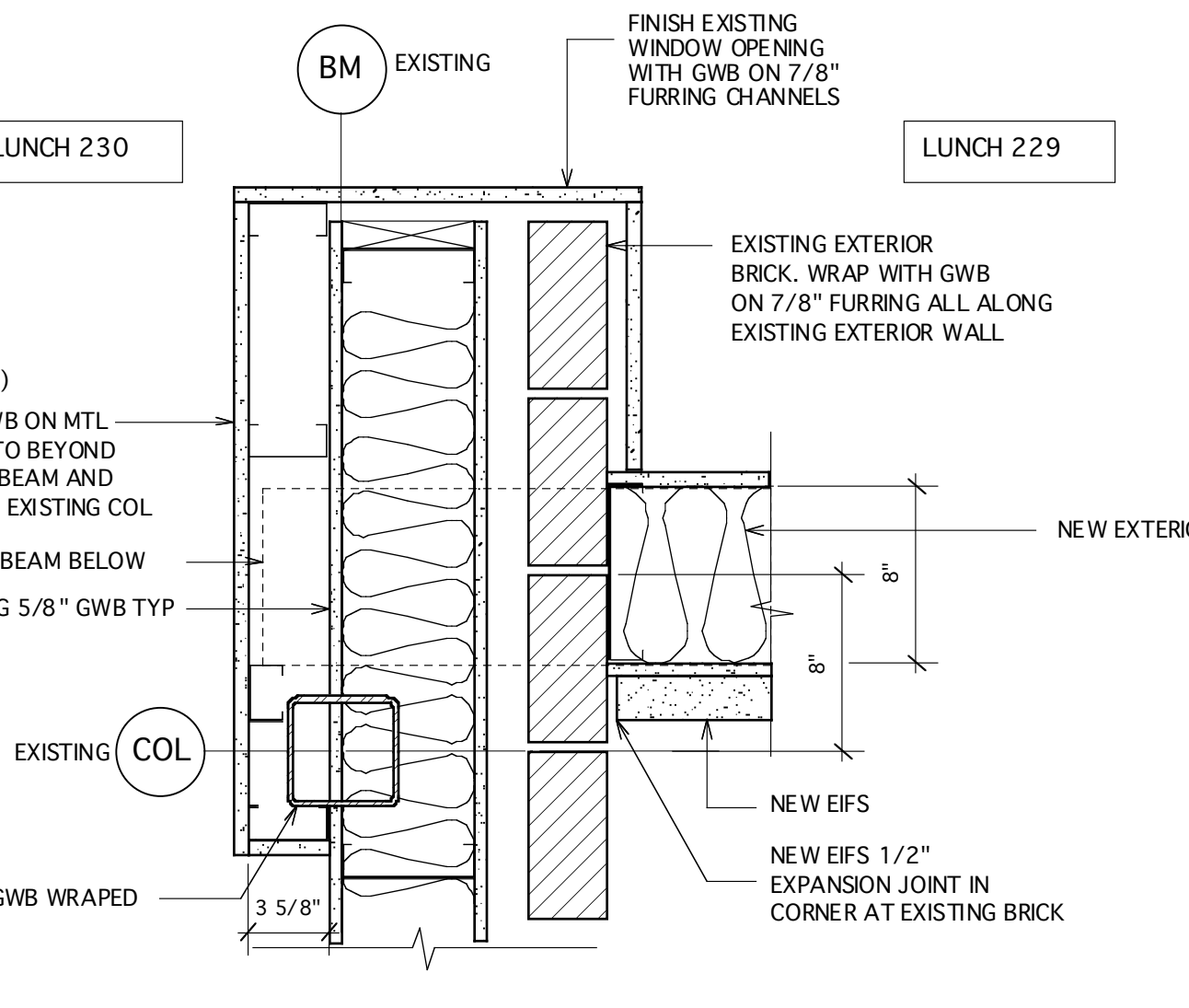

5.1 DTL AT NEW LUNCH
Scale: 1 1/2" = 1'-0"

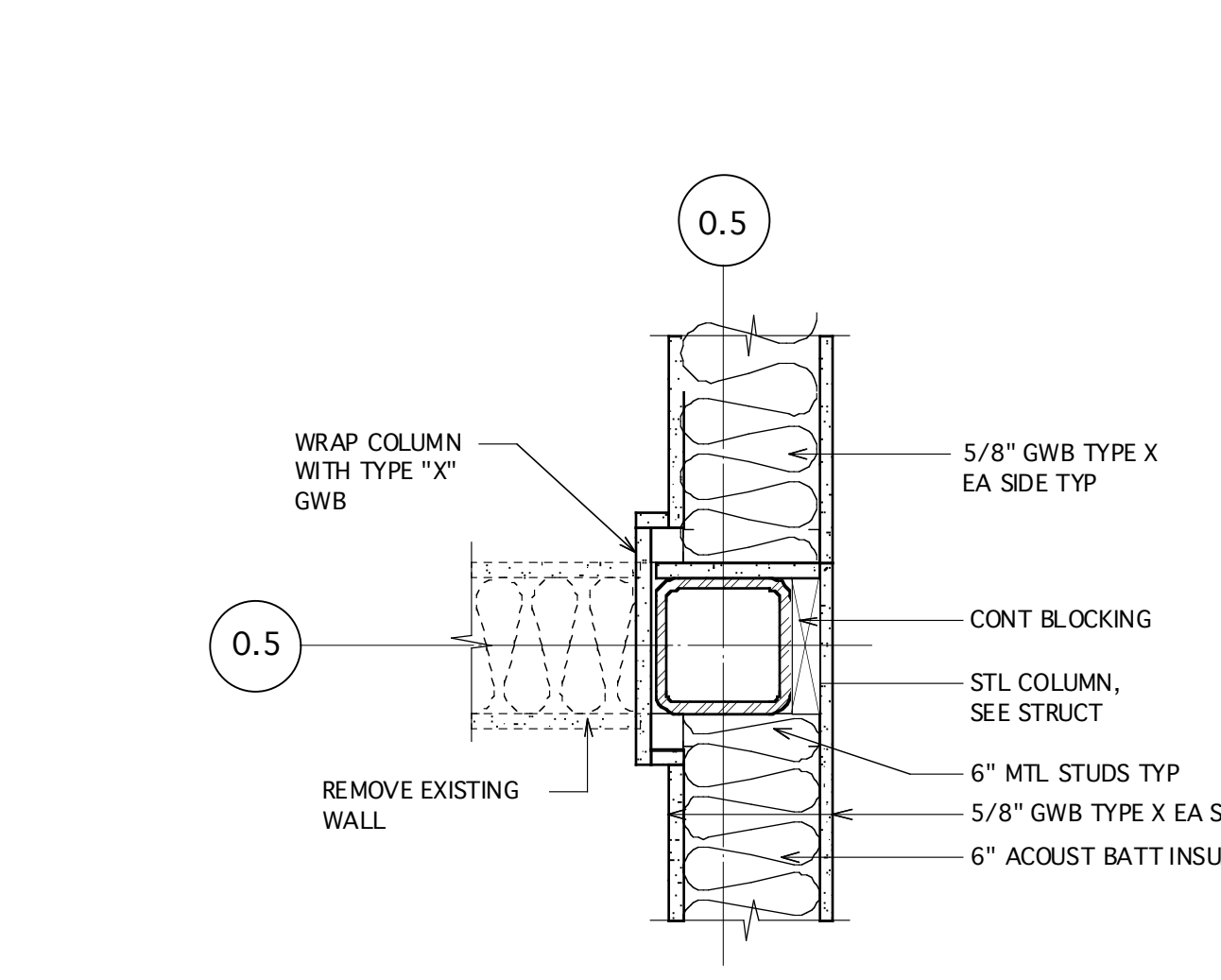

6 DTL @ STAIR CORNER
Scale: 1 1/2" = 1'-0"

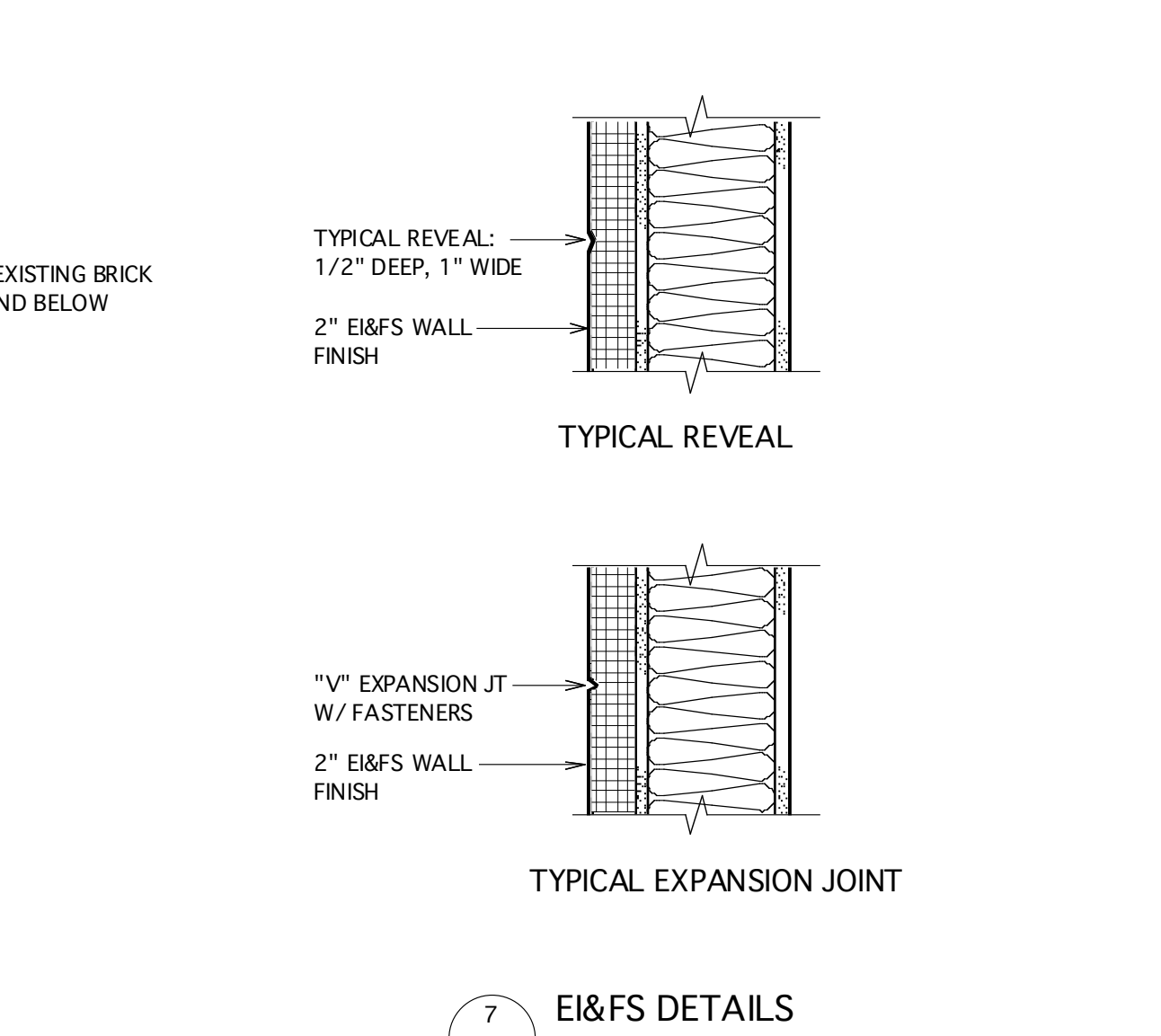

7 EI&FS DETAILS
Scale: 1 1/2" = 1'-0"

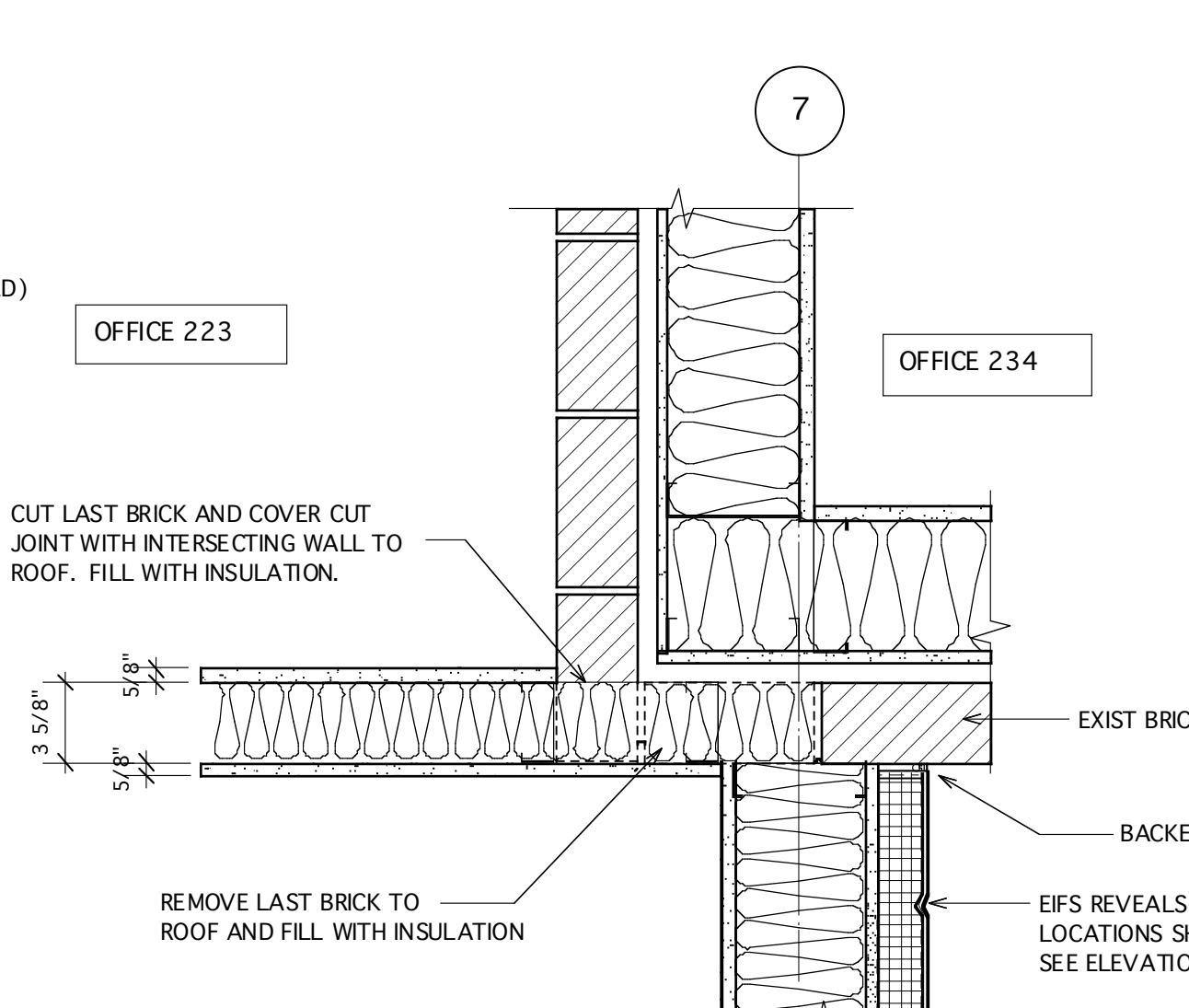

13 DTL @ OUTSIDE CORNER
Scale: 1 1/2" = 1'-0"

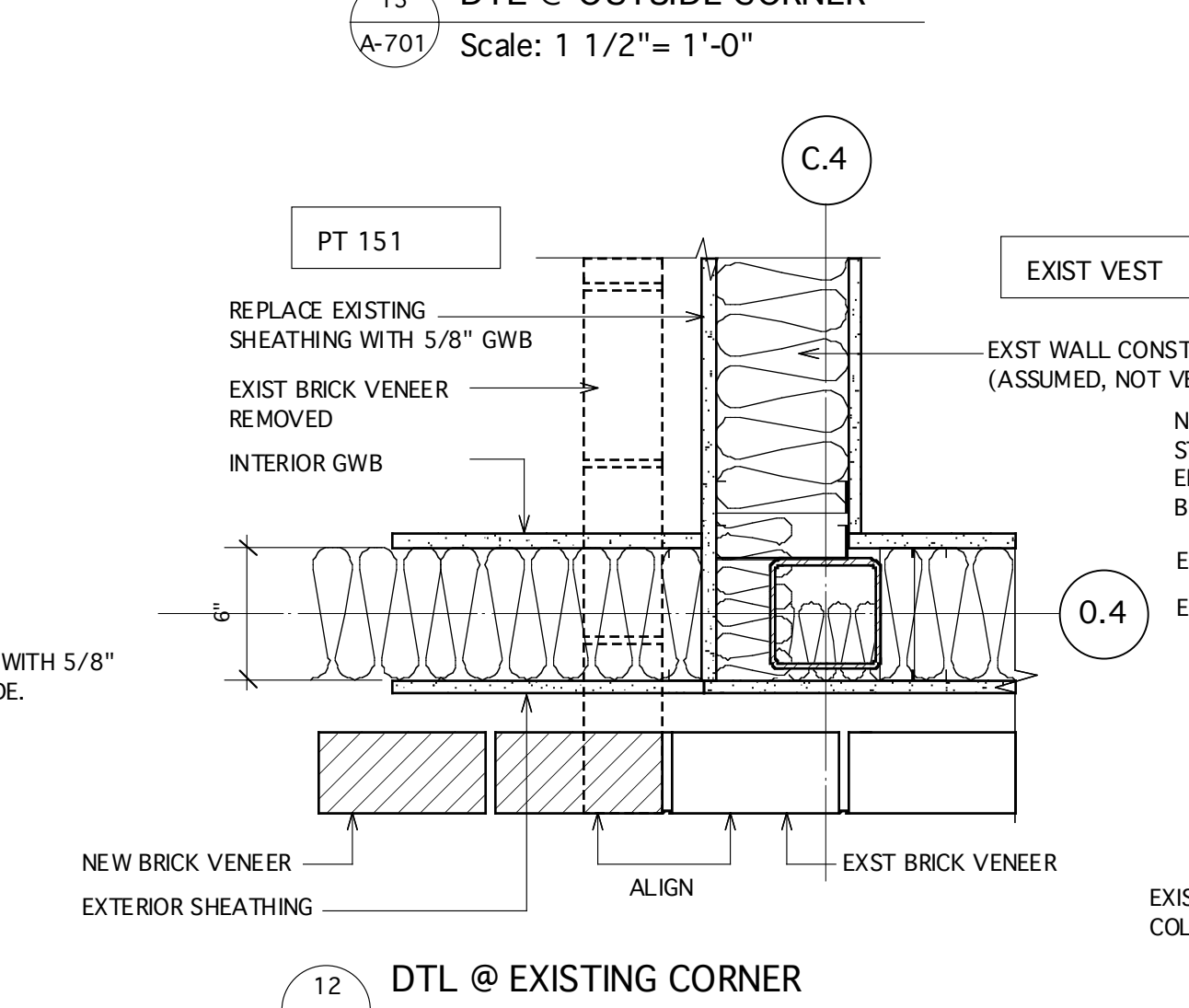

12 DTL @ EXISTING CORNER
Scale: 1 1/2" = 1'-0"

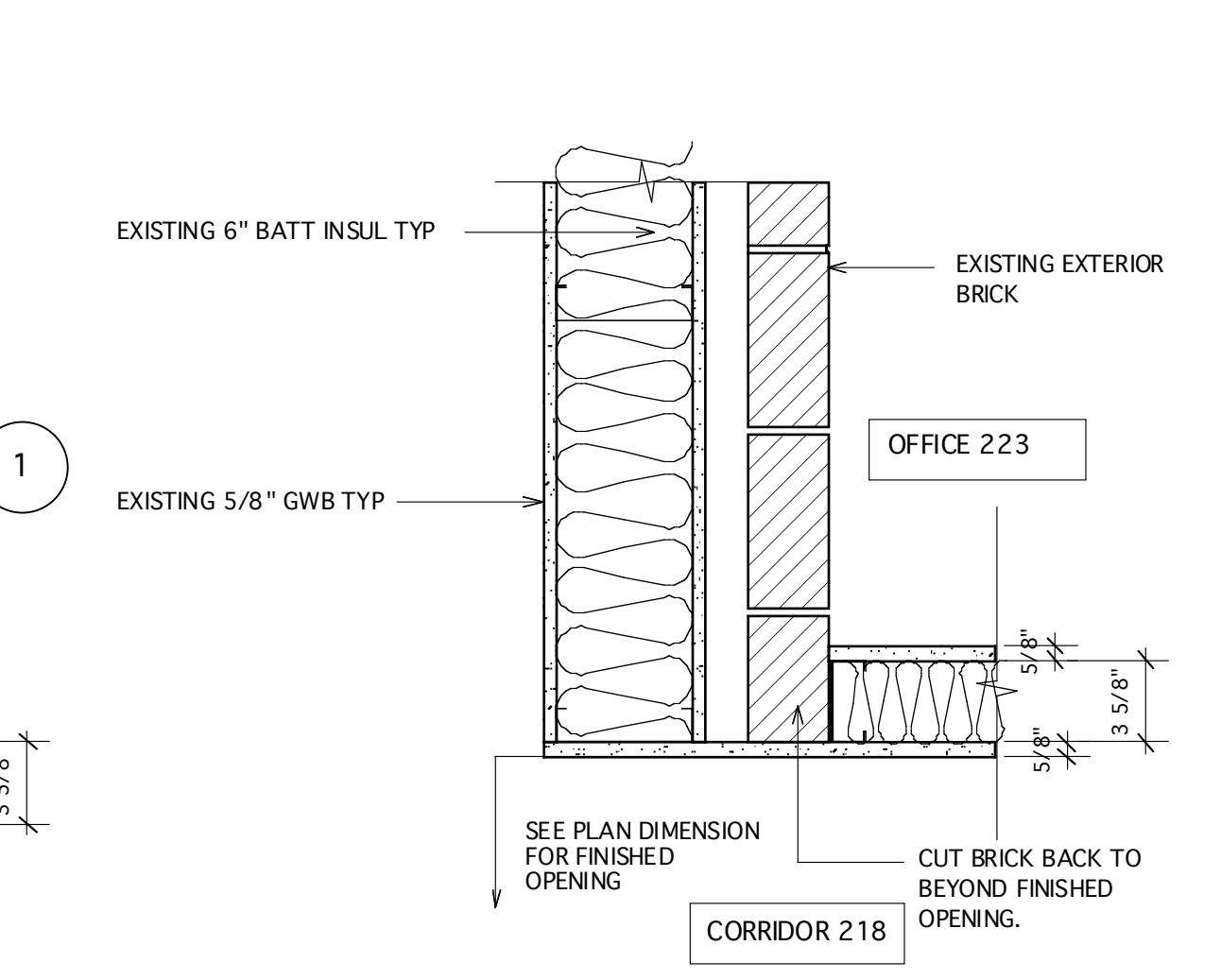

9 DTL AND NEW CORRIDOR OPENING
Scale: 1 1/2" = 1'-0"

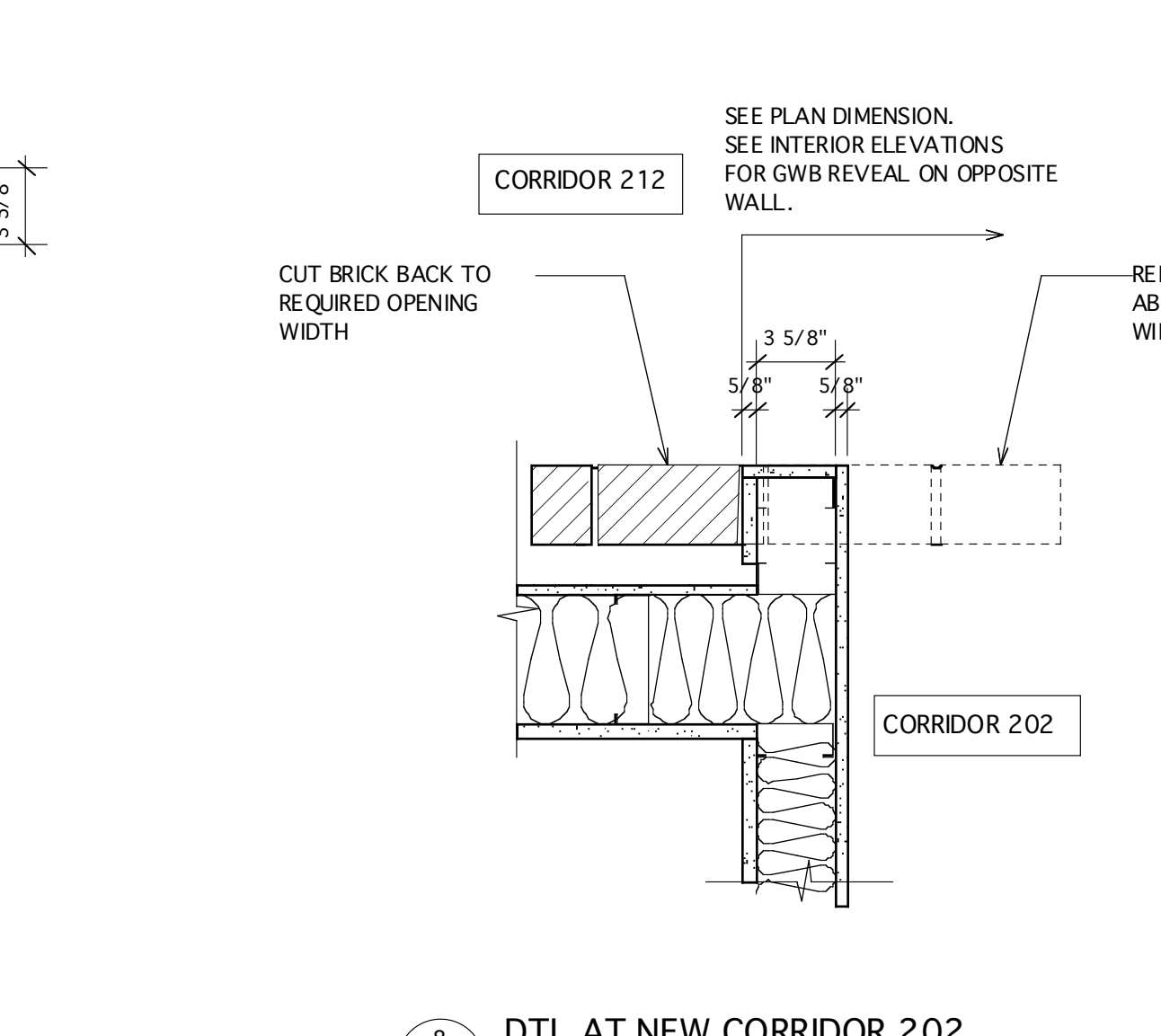

8 DTL AT NEW CORRIDOR 202
Scale: 1 1/2" = 1'-0"

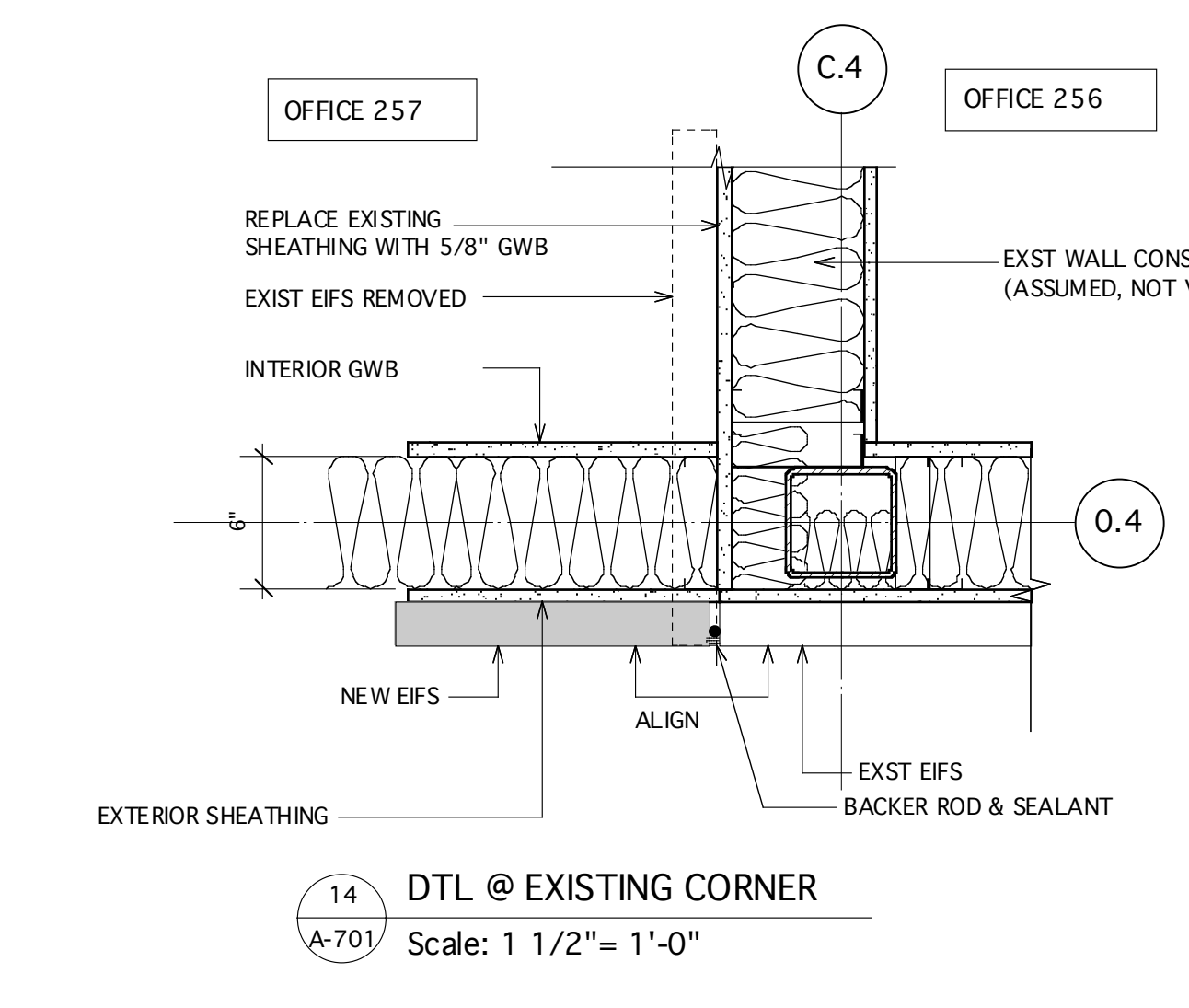

14 DTL @ EXISTING CORNER
Scale: 1 1/2" = 1'-0"

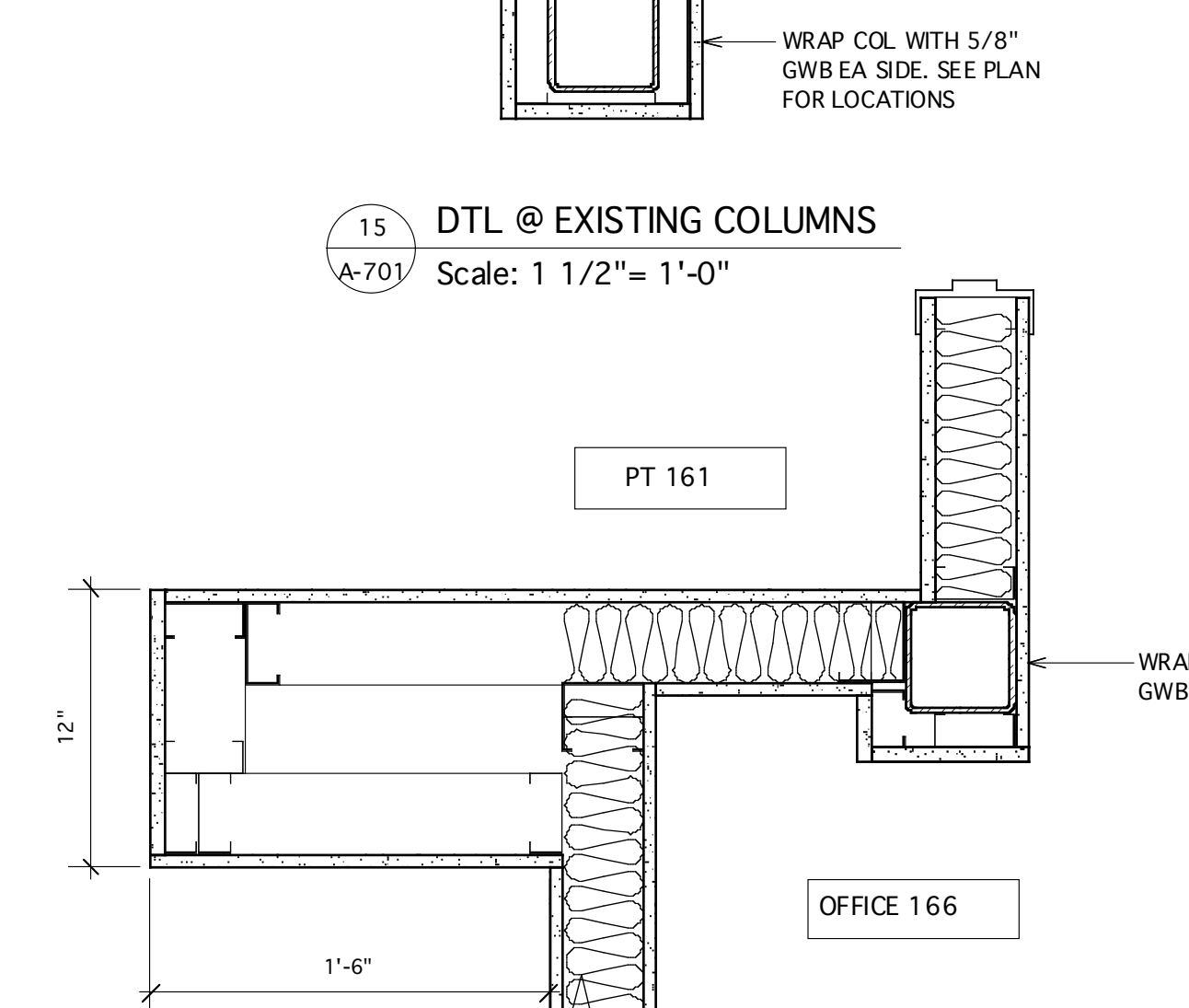

15 DTL @ EXISTING COLUMNS
Scale: 1 1/2" = 1'-0"

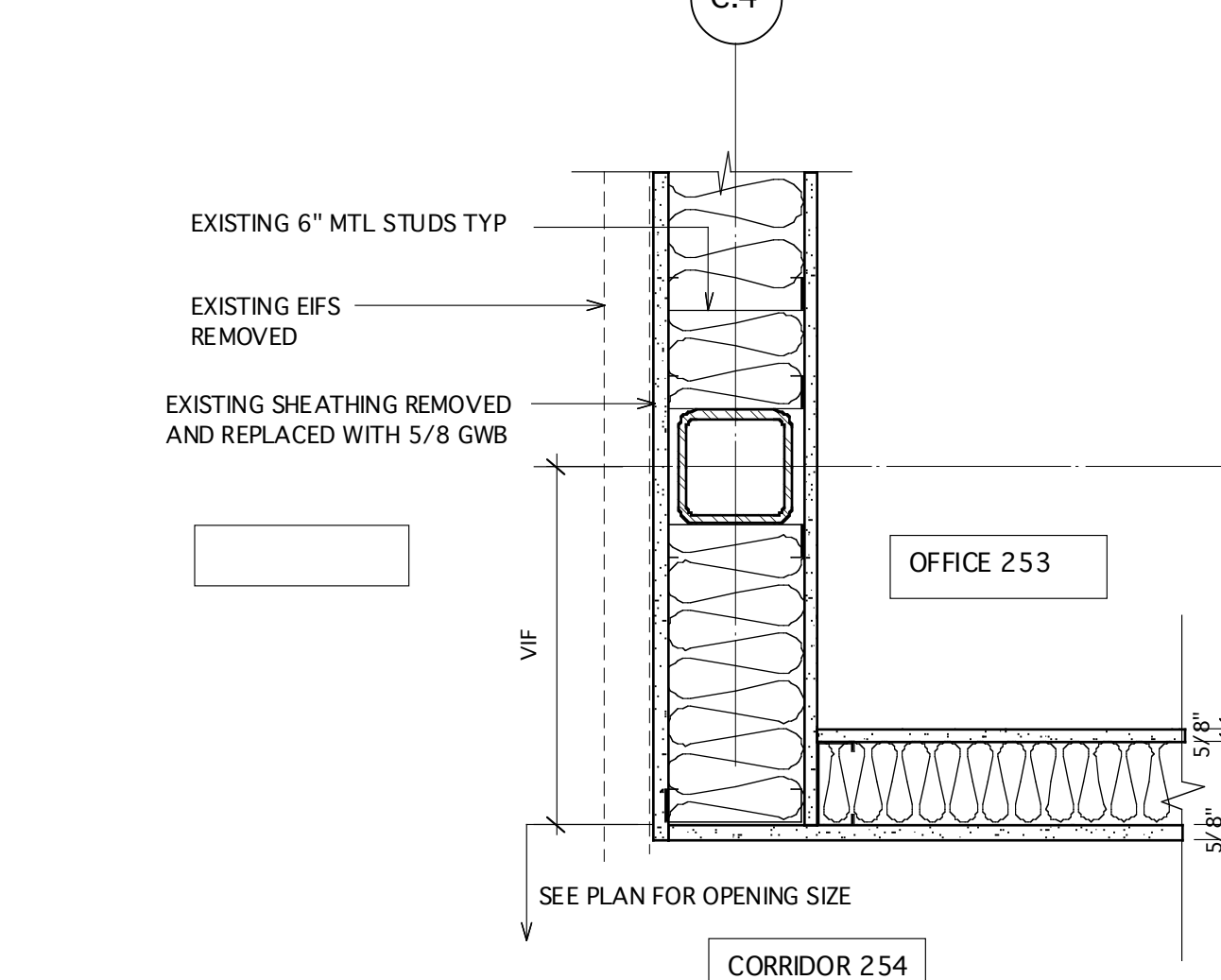

16 DTL @ EXISTING COLUMN
Scale: 1 1/2" = 1'-0"

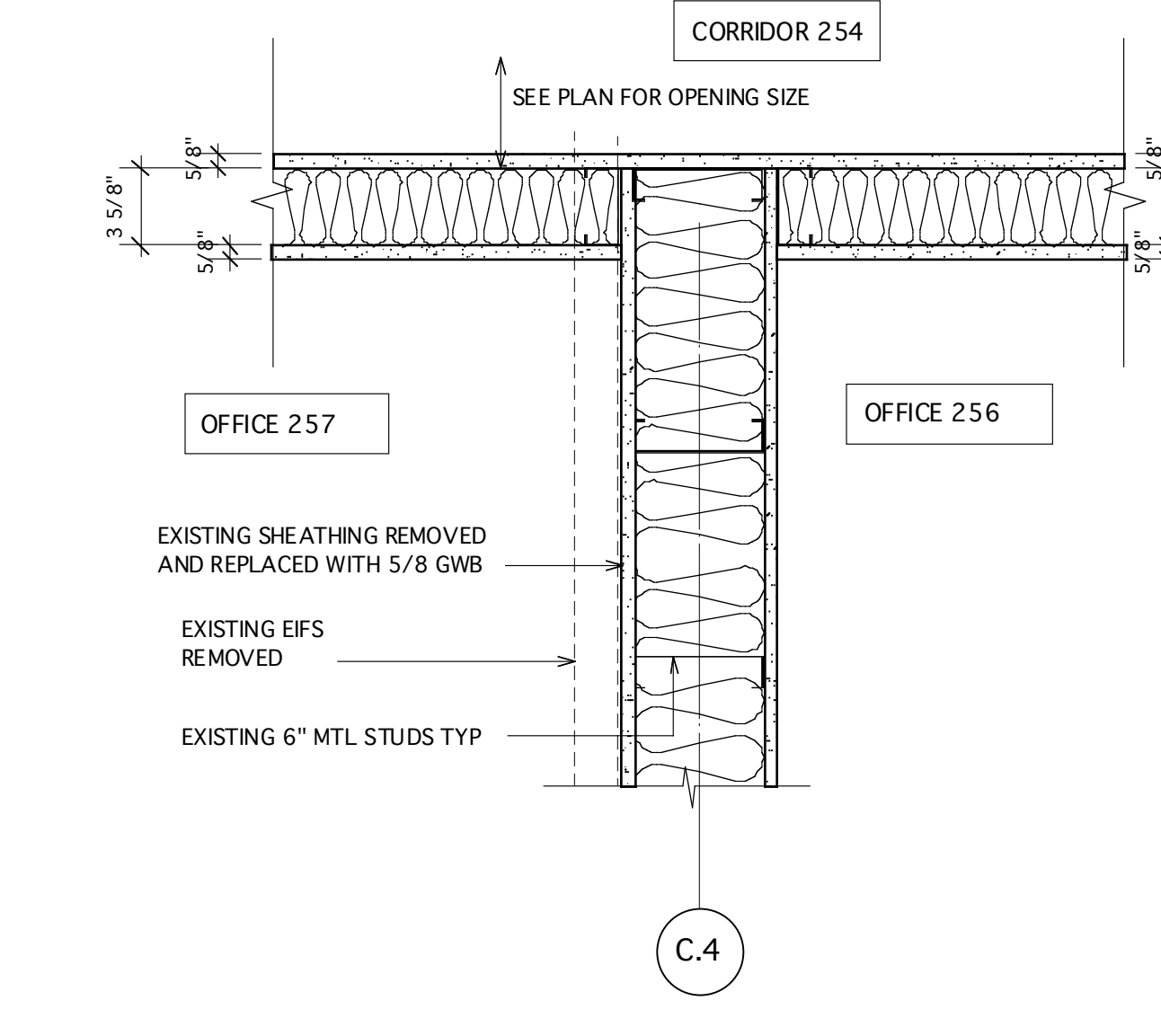

10 DTL @ 2nd FLR OPENING TO EXPANSION
Scale: 1 1/2" = 1'-0"

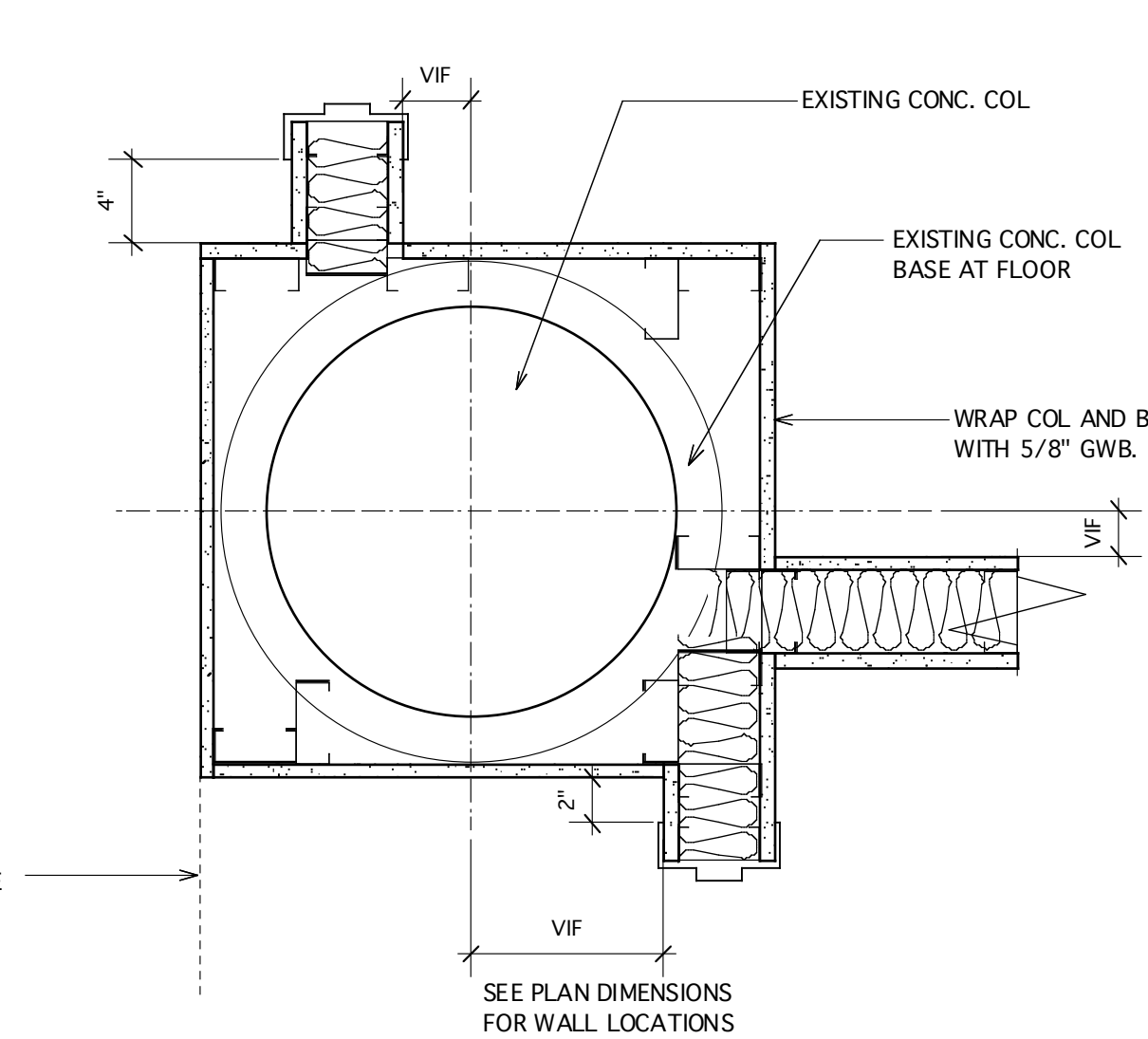

17 DTL @ EXISTING CONC. COLUMN
Scale: 1 1/2" = 1'-0"

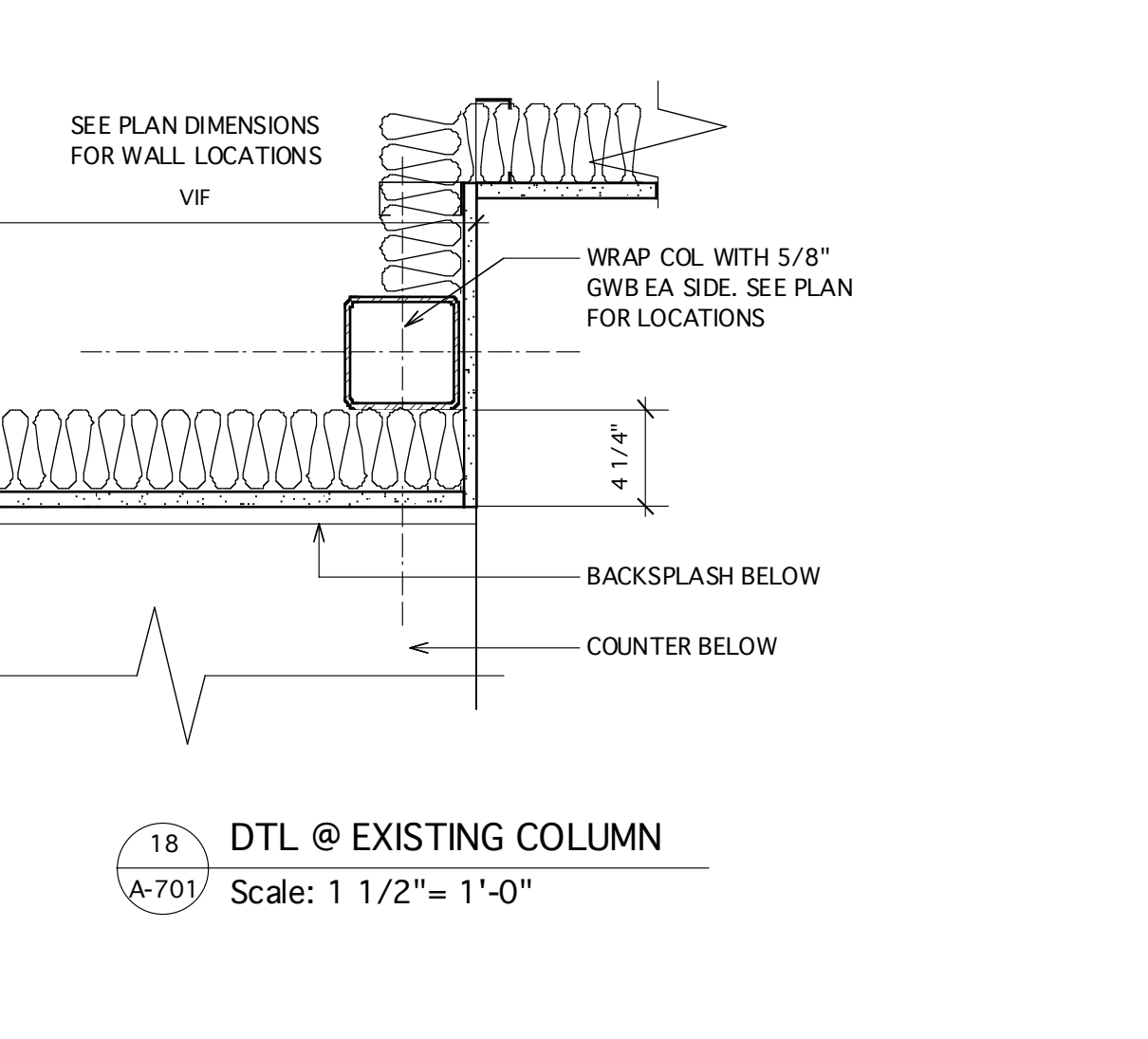

18 DTL @ EXISTING COLUMN
Scale: 1 1/2" = 1'-0"

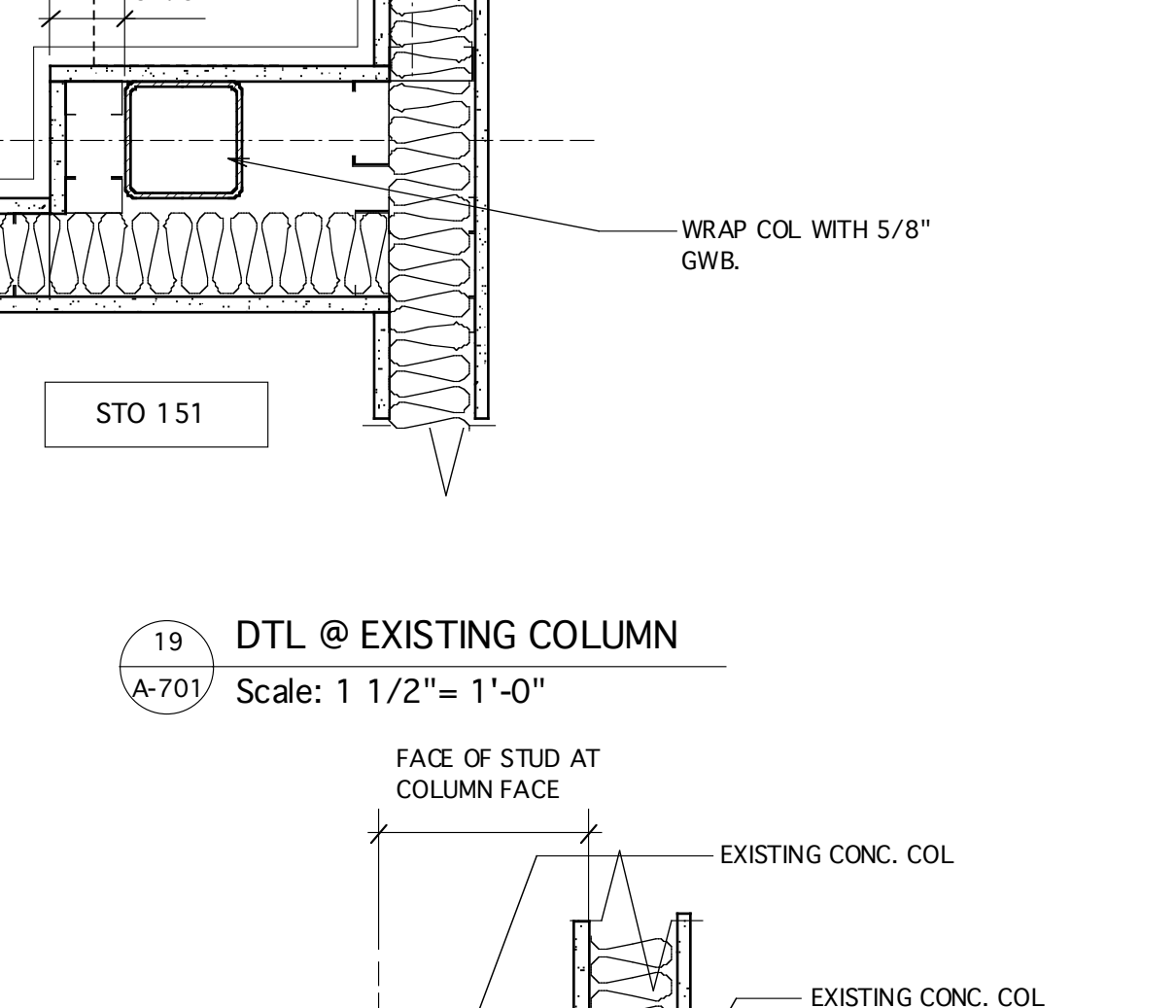

19 DTL @ EXISTING COLUMN
Scale: 1 1/2" = 1'-0"

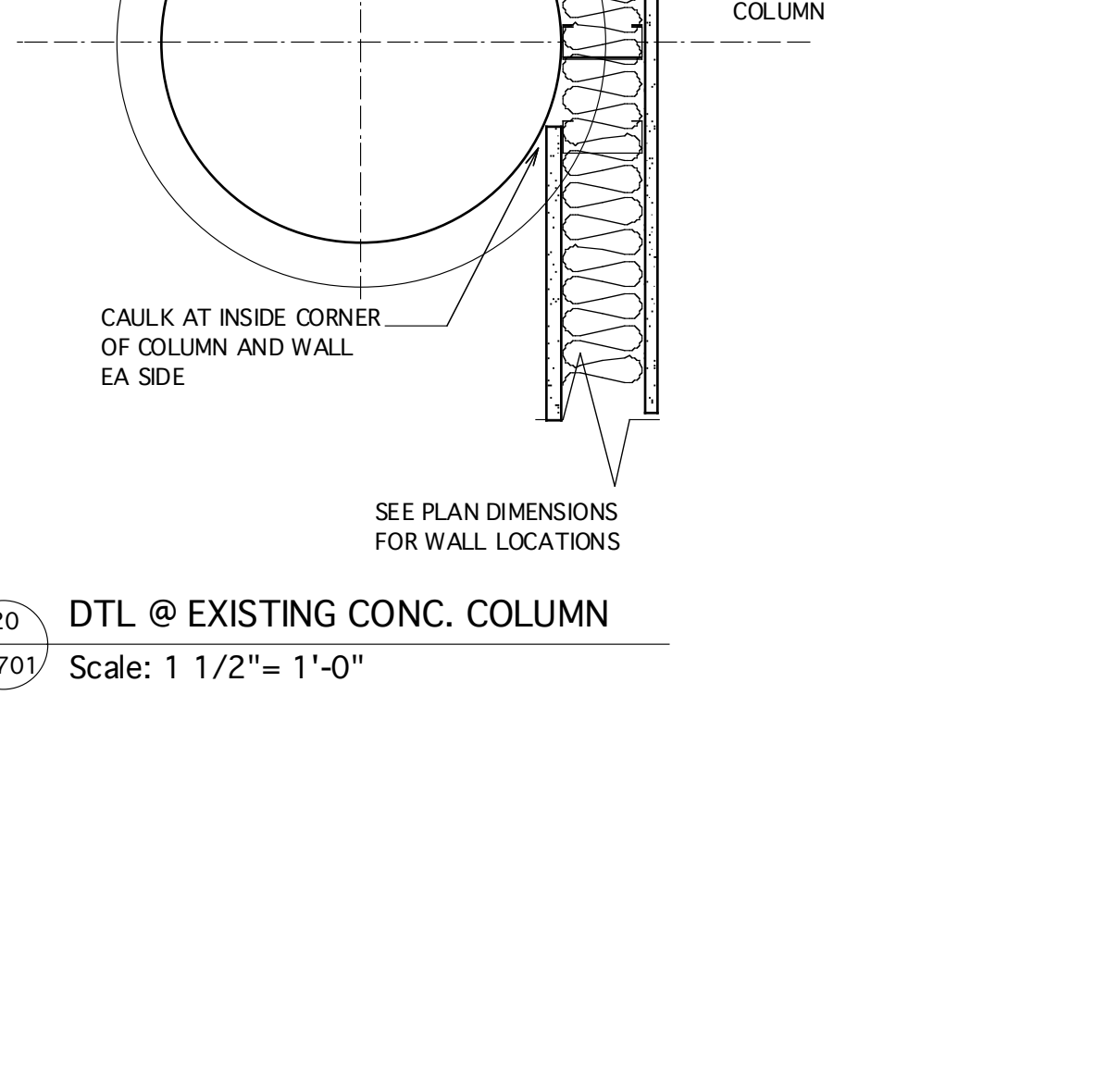

20 DTL @ EXISTING CONC. COLUMN
Scale: 1 1/2" = 1'-0"