

1
A2.2
1st FLR HALL
SCALE: 1/4" = 1'-0"

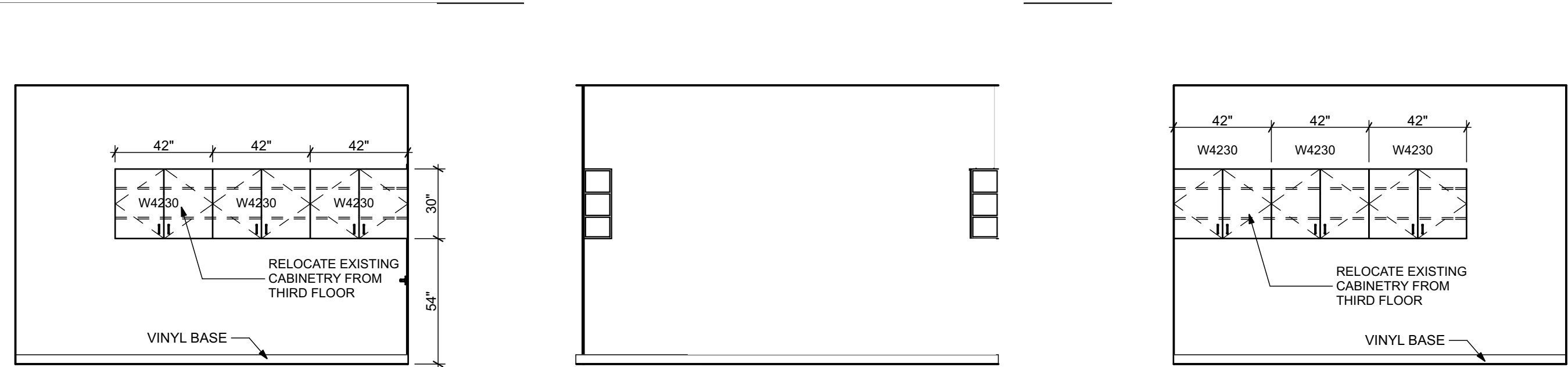

2
A2.2
MEDICAL RECORDS 111
SCALE: 1/4" = 1'-0"

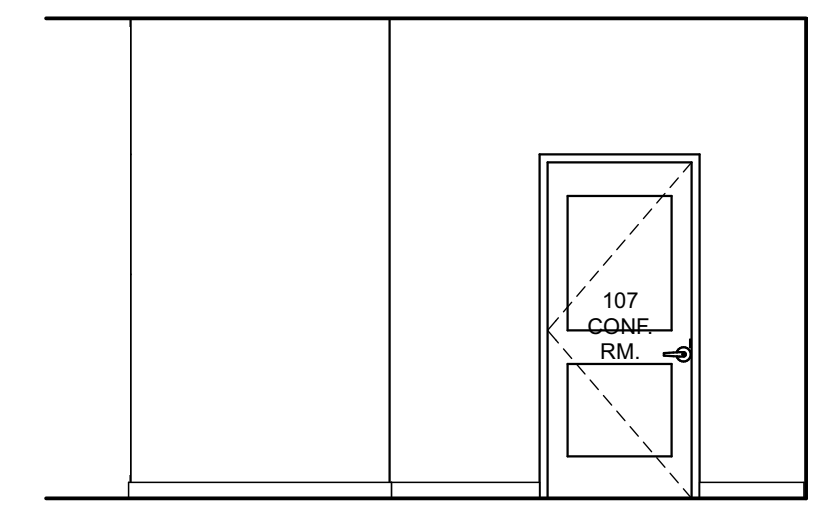
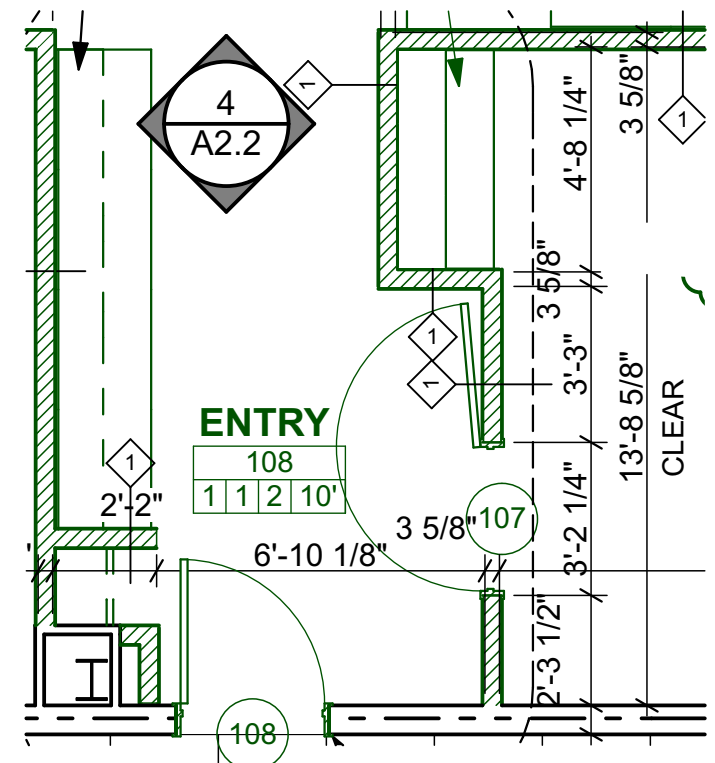

4
A2.2
ENTRY 108
SCALE: 1/4" = 1'-0"

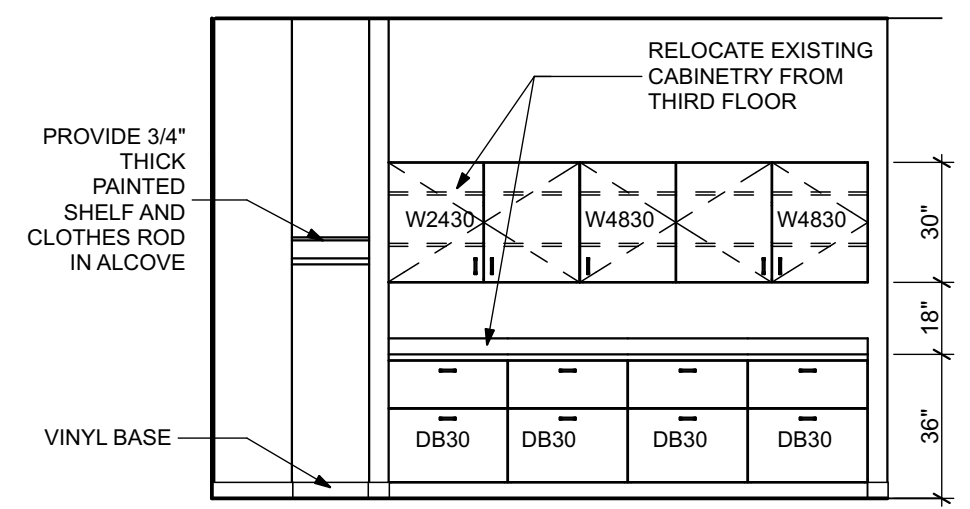

5
A2.2
TYP. 8' CASEWORK @ PROCEDURE RMS
SCALE: 1/4" = 1'-0"

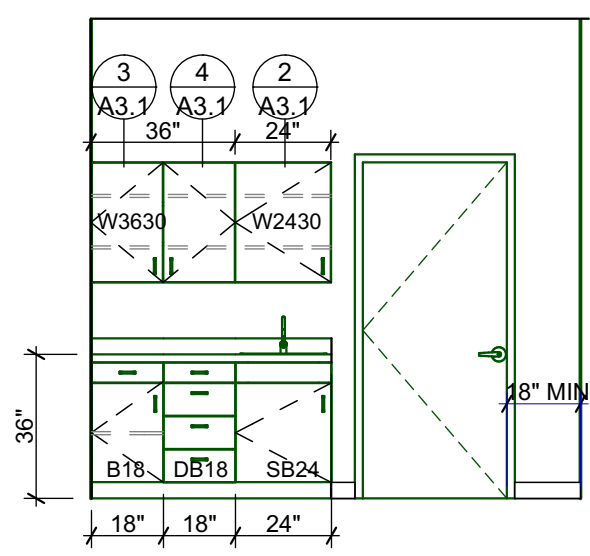
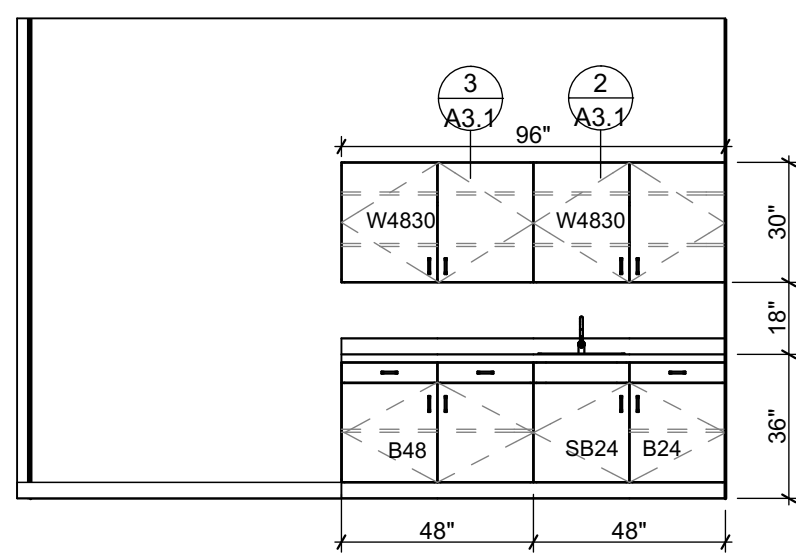

6
A2.2
TYP. EXAM RM. CASEWORK
SCALE: 1/4" = 1'-0"

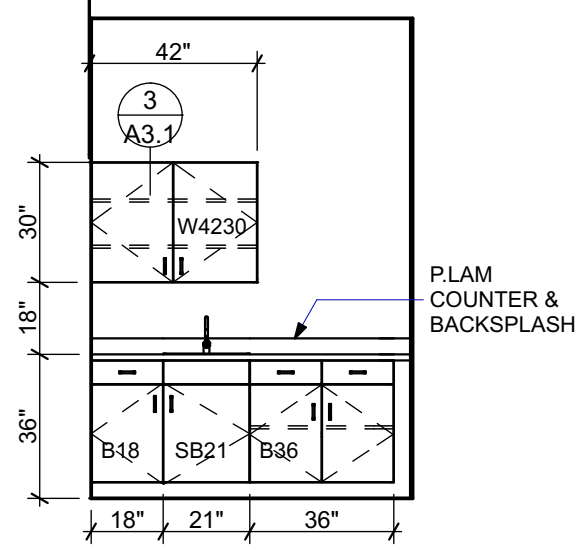
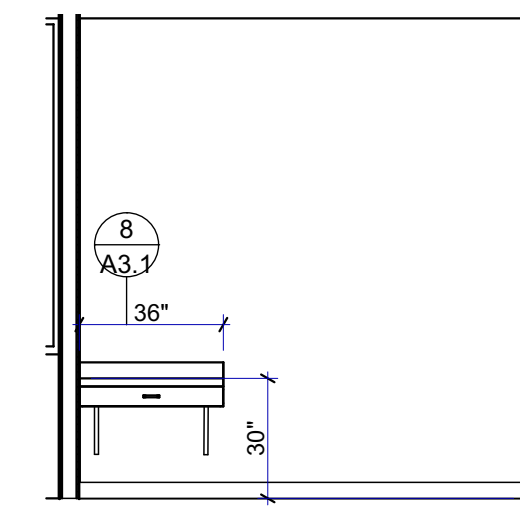

7
A2.2
AUTOCLAVE
SCALE: 1/4" = 1'-0"

3
A2.2
ENTRY 108- 1 ST FLR
SCALE: 1/4" = 1'-0"

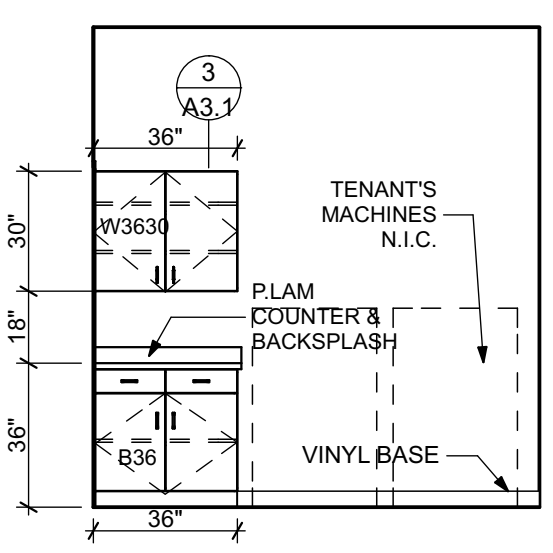

8
A2.2
LAB 309
SCALE: 1/4" = 1'-0"

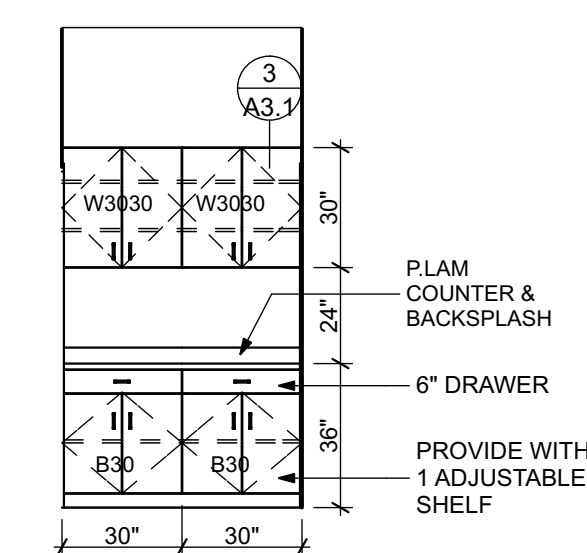
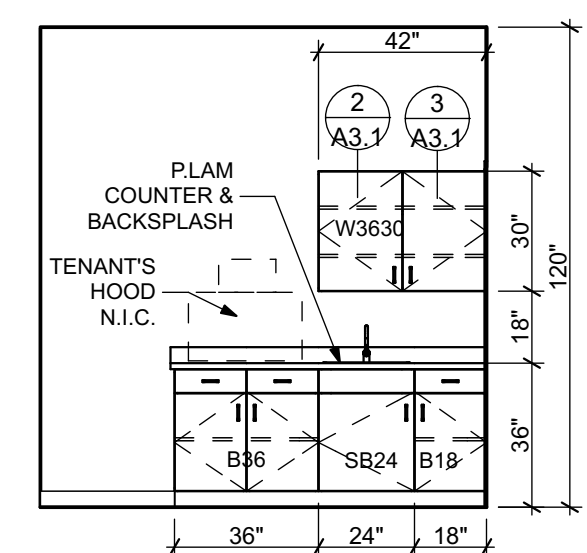

9
A2.2
STAFF 321
SCALE: 1/4" = 1'-0"

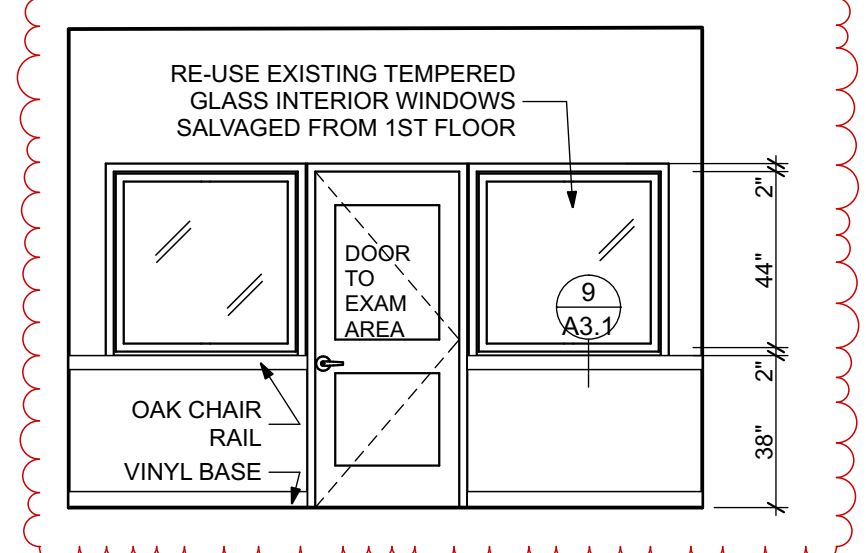

10
A2.2
WAITING RM 316
SCALE: 1/4" = 1'-0"

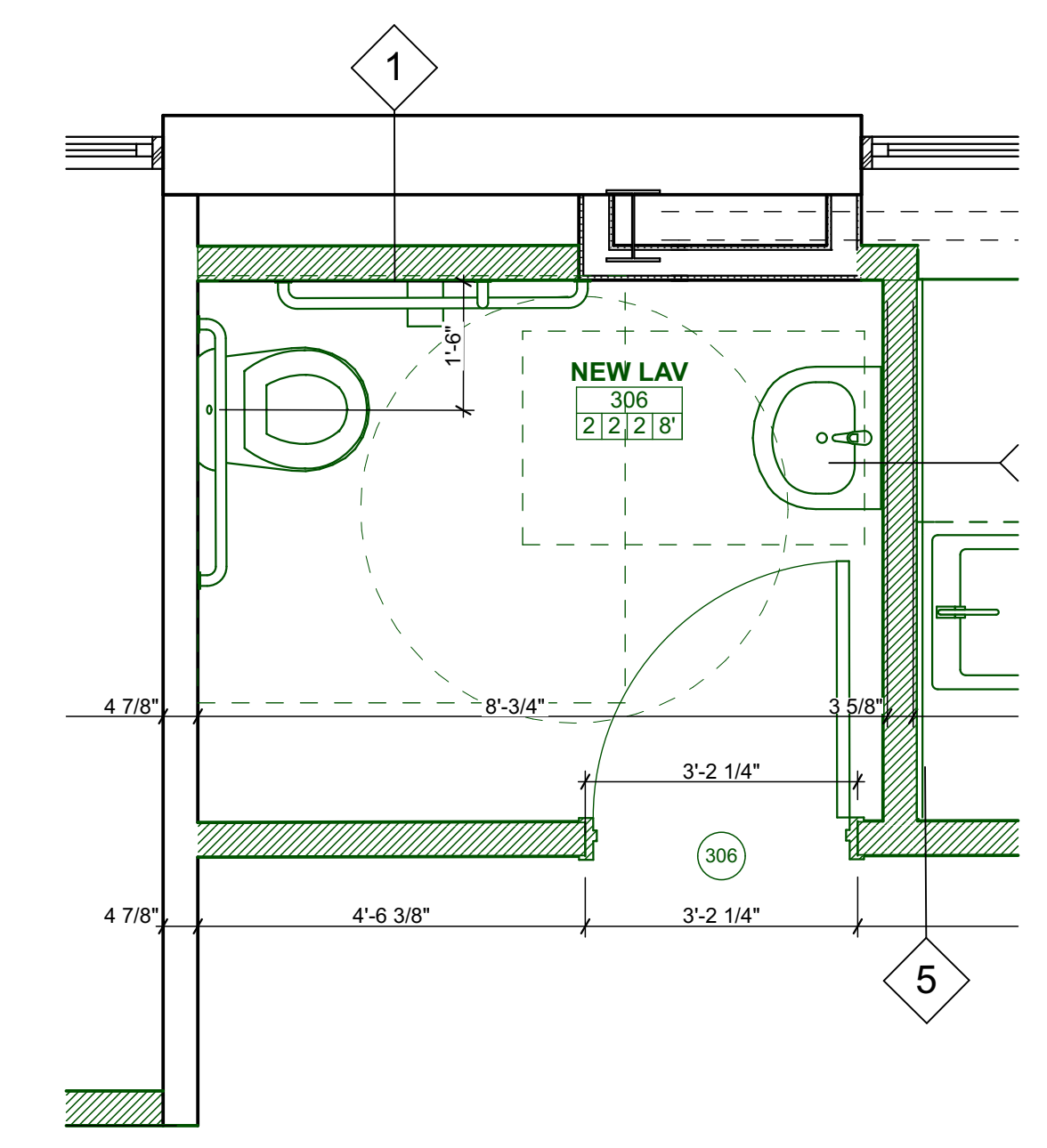
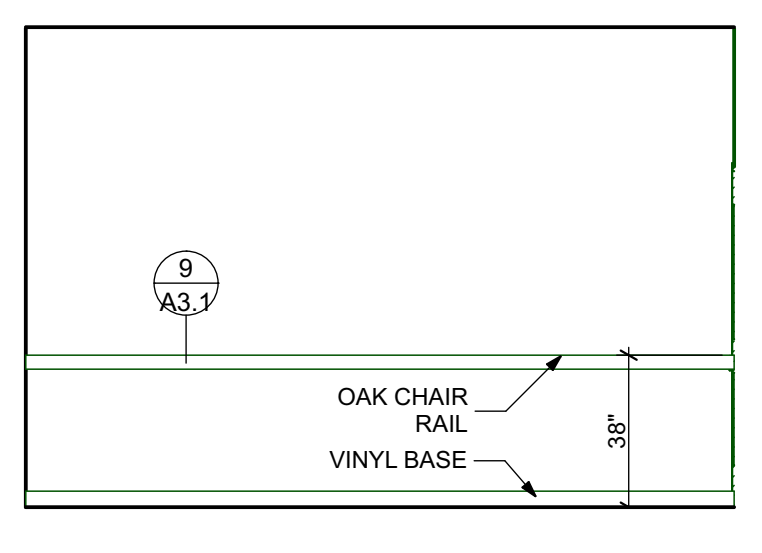
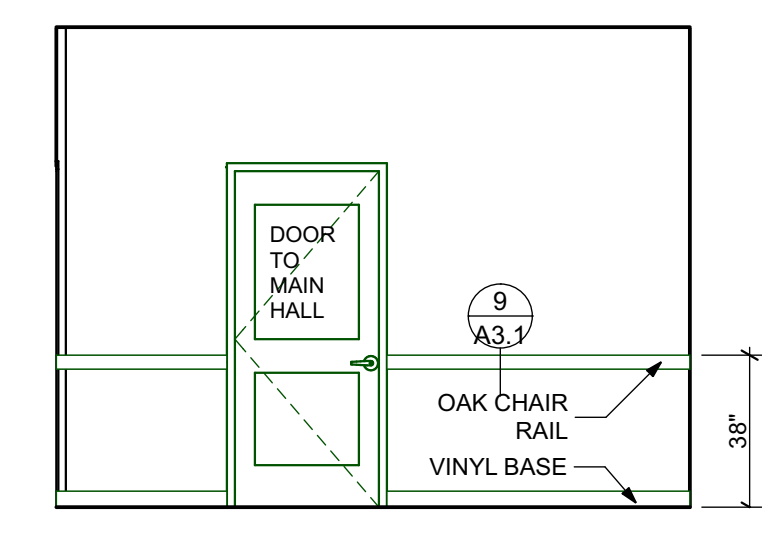
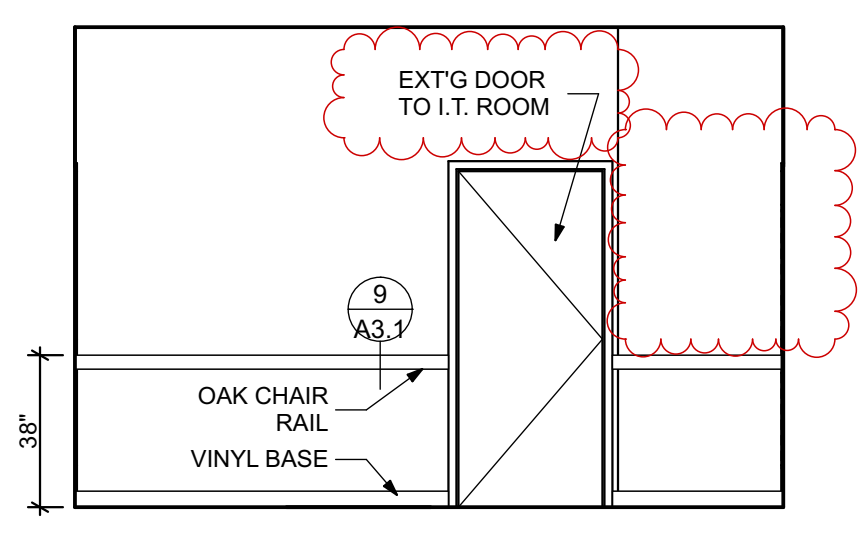

11
A2.2
NEW LAV 306
SCALE: 1/2" = 1'-0"

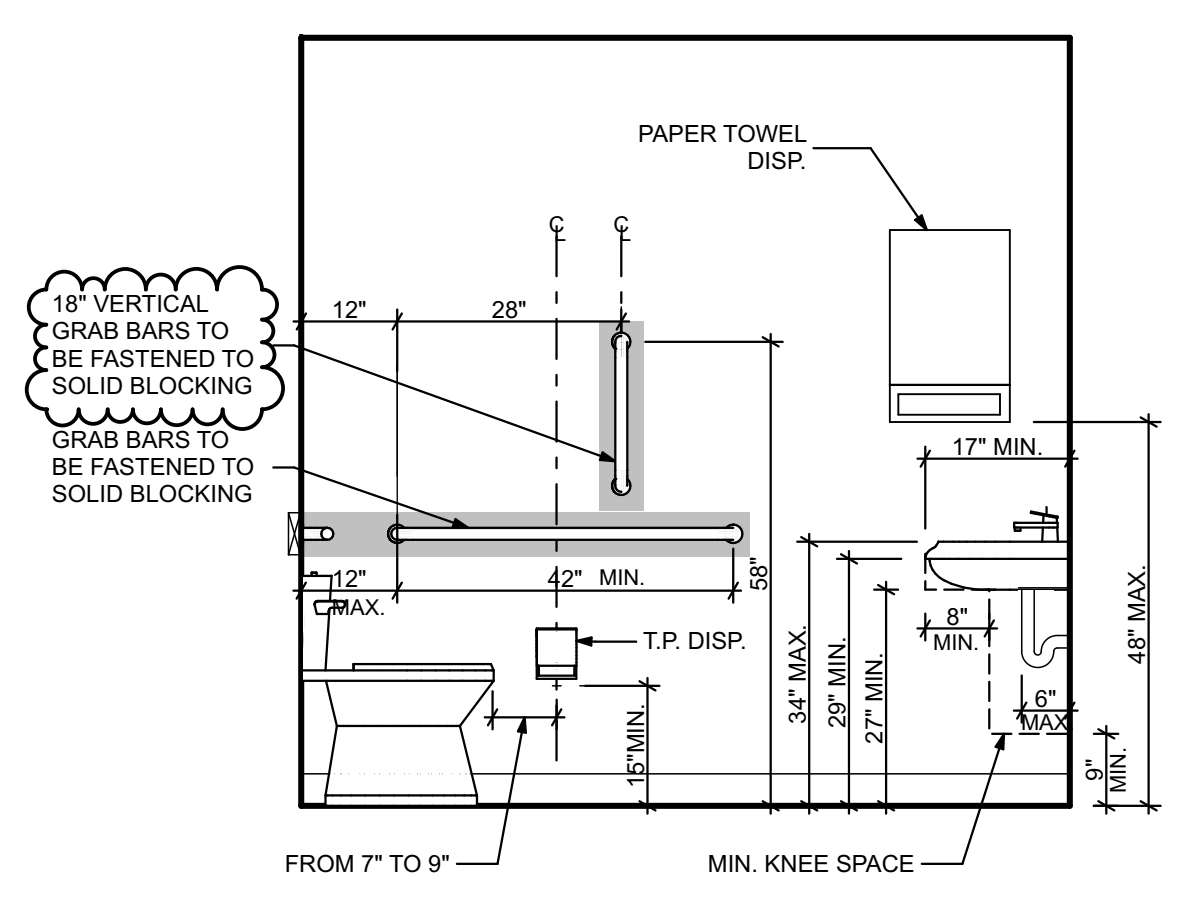

12
A2.2
NEW LAV 306
SCALE: 1/2" = 1'-0"

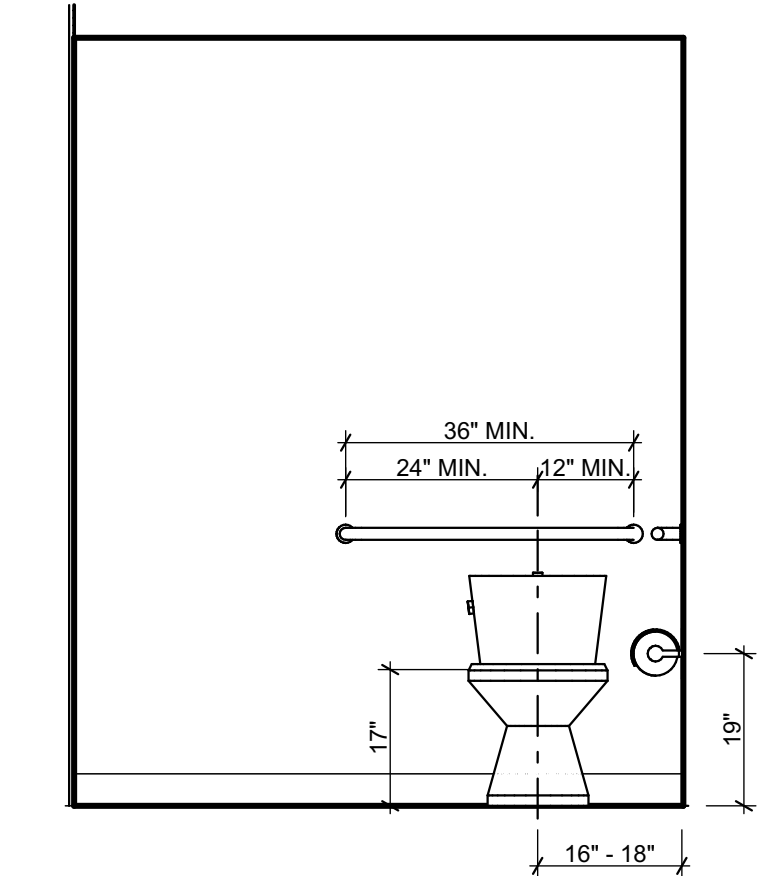
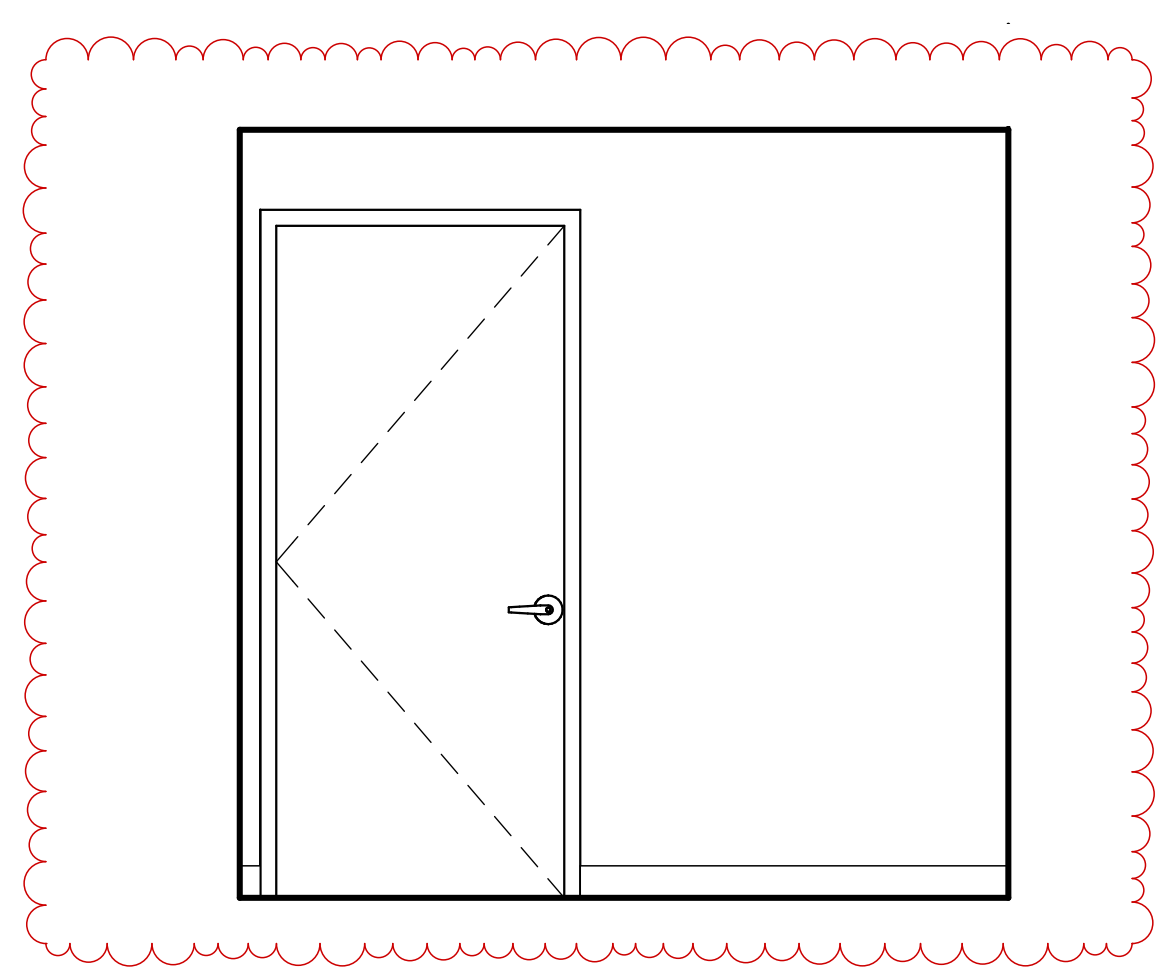
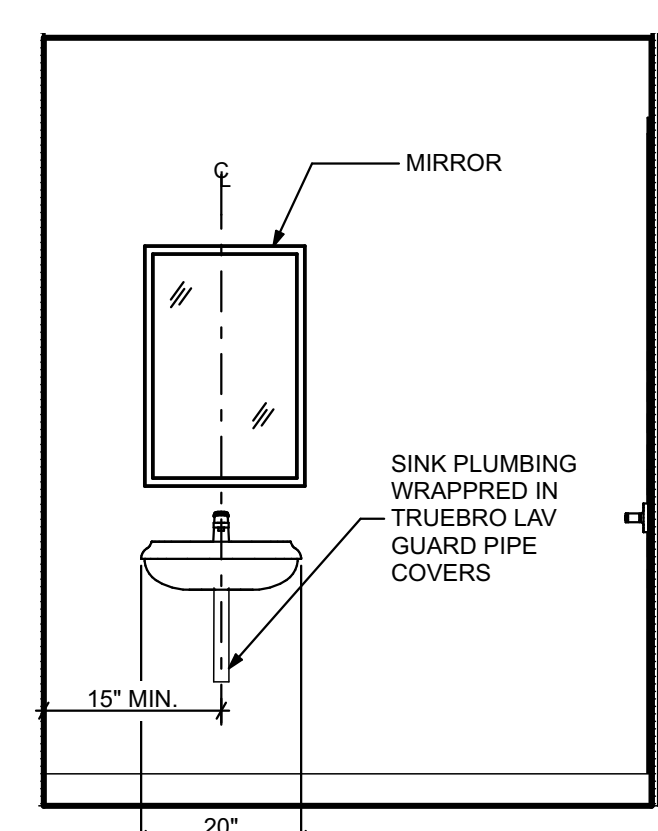

GENERAL NOTES:

1. VERIFY ALL DIMENSIONS IN THE FIELD. REPORT ALL DISCREPANCIES TO ARCHITECT PRIOR TO COMMENCEMENT WITH WORK.
2. NOTED DIMENSIONS TAKE PRECEDENT OVER SCALED DIMENSIONS. LARGE DETAILS TAKE PRECEDENT OVER SMALL SCALED DETAILS.
3. ALL NEW CONSTRUCTION DIMENSIONS ARE ROUGH OPENINGS UNLESS NOTED OTHERWISE. DIMENSIONS TO EXISTING WALL CONSTRUCTION ARE TO FINISH SURFACE.
4. PROVIDE SOLID BLOCKING FOR ALL CABINETS AND ACCESSORIES. REVIEW INTERIOR ELEVATIONS AND DETAILS FOR LOCATIONS.

ISSUED FOR PERMITTING DECEMBER 20, 2016
ISSUED FOR PRICING OCTOBER 5, 2016

THIS DRAWING IS AN INSTRUMENT OF SERVICE AND SHALL REMAIN THE PROPERTY OF WHIPPLE CALLENDER ARCHITECTS. IT SHALL NOT BE USED FOR ANY OTHER PURPOSE THAT FOR WHICH IT IS SPECIFICALLY FURNISHED.

DERMATOLOGY ASSOCIATES
PORTLAND, MAINE
50 SEWALL ST

LICENSED ARCHITECT
ANNE E. CALLENDER
No. 1861
STATE OF MAINE

WHIPPLE CALLENDER ARCHITECTS

136 PLEASANT AVE.
PORTLAND, ME 04103
P 207.775.2696
F 207.775.3631
www.whipplecallender.com

DATE	DESCRIPTION
10/5/2016	ISSUED FOR PRICING
10/21/2016	ELECT/DATA/UPDATES TO PRICING SET
12/20/2016	UPDATES + PERMITTING

DATE: 12/20/16
CHECKED BY: AEC
DRAWN BY: CCL / NPC
JOB: 16-DAP
SHEET TITLE: INTERIOR ELEVATIONS

A2.2