

11 RESERVED
 SCALE: N.T.S.

10 GLASS DOOR SILL DETAIL
 A001 SCALE: 3" = 1'-0"

9 GLASS DOOR JAMB DETAIL
 A001 SCALE: 3" = 1'-0"

5 STAIR ELEVATION
 A101 SCALE: 1/2" = 1'-0"

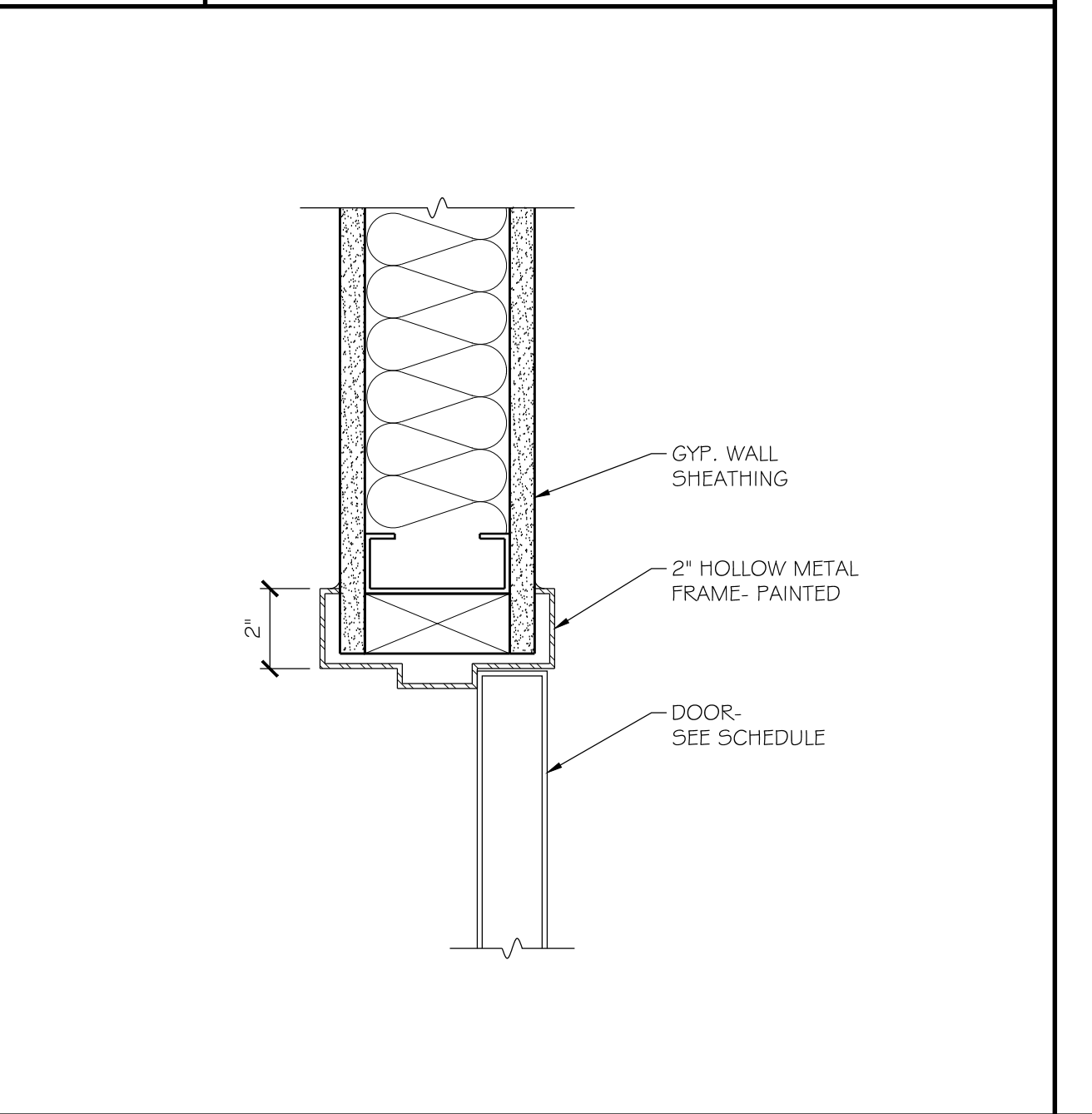
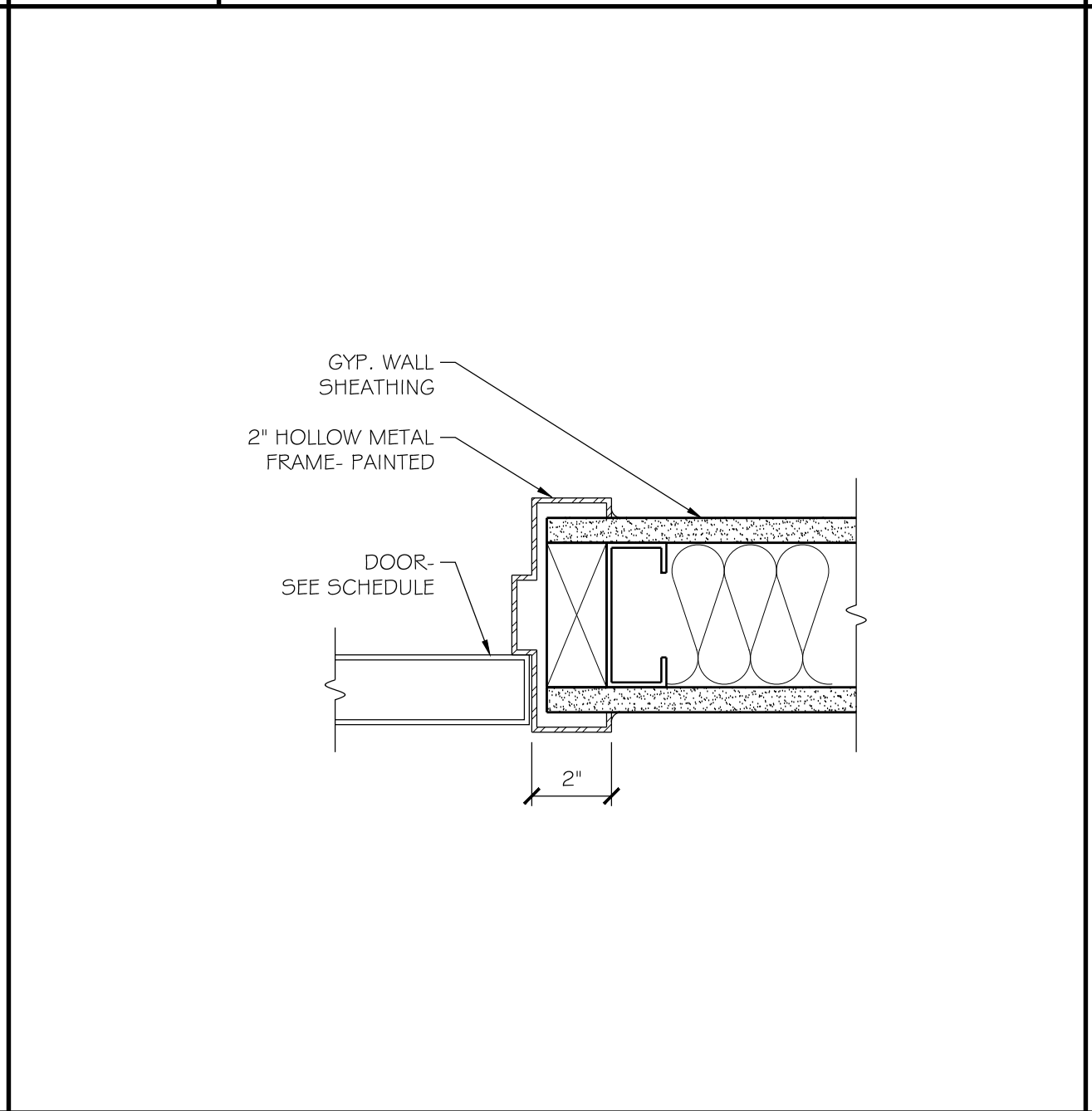
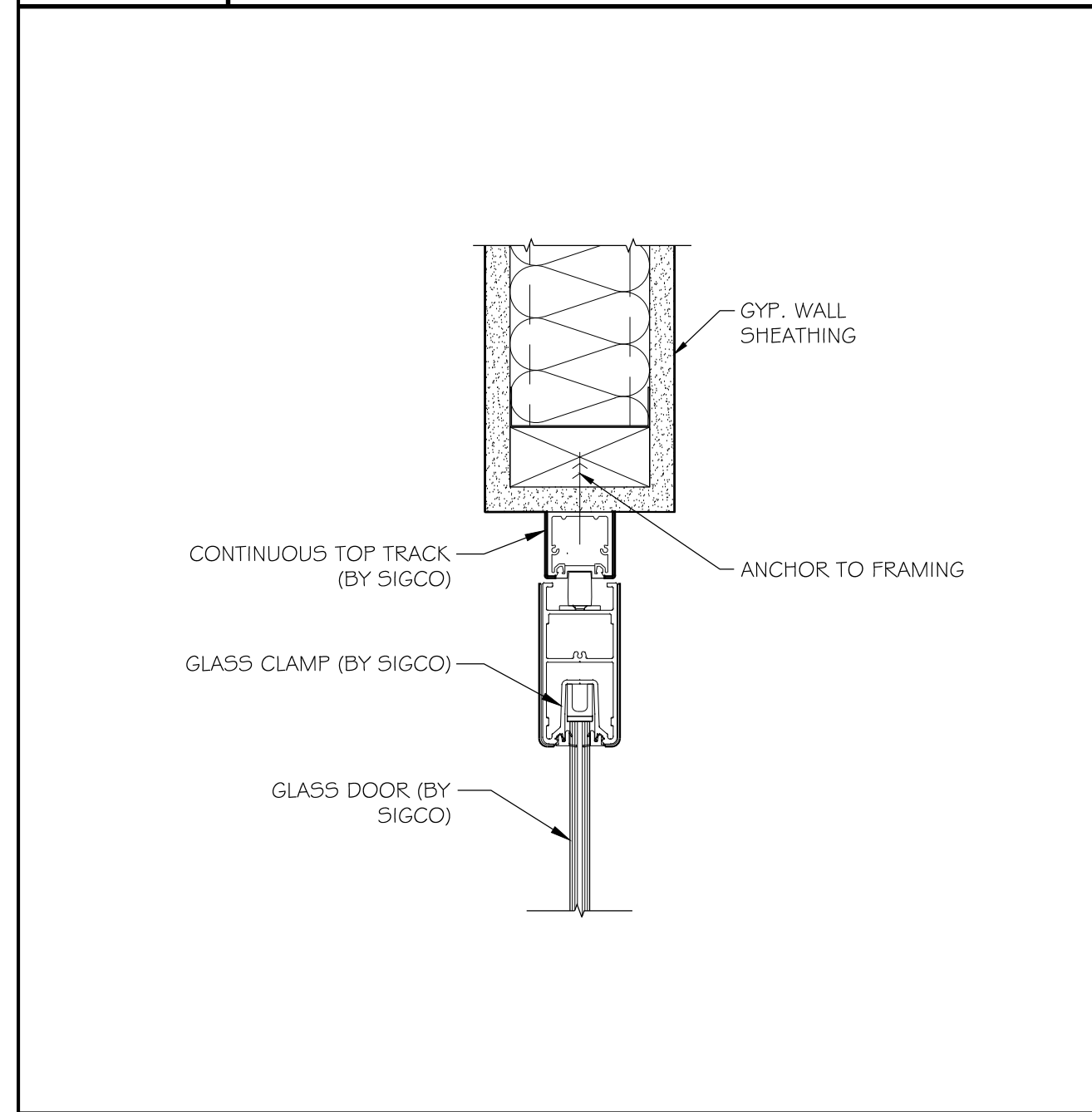

8 GLASS DOOR HEAD DETAIL
 A001 SCALE: 3" = 1'-0"

7 H. M. FRAME JAMB DETAIL
 A001 SCALE: 3" = 1'-0"

6 H. M. FRAME HEAD DETAIL
 A001 SCALE: 3" = 1'-0"

4 REMOVABLE ADA CABINET BASE DTL.
 A101-A103 SCALE: 1" = 1'-0"

3 JANITOR SINK DETAIL
 A101-A103 SCALE: 1/2" = 1'-0"

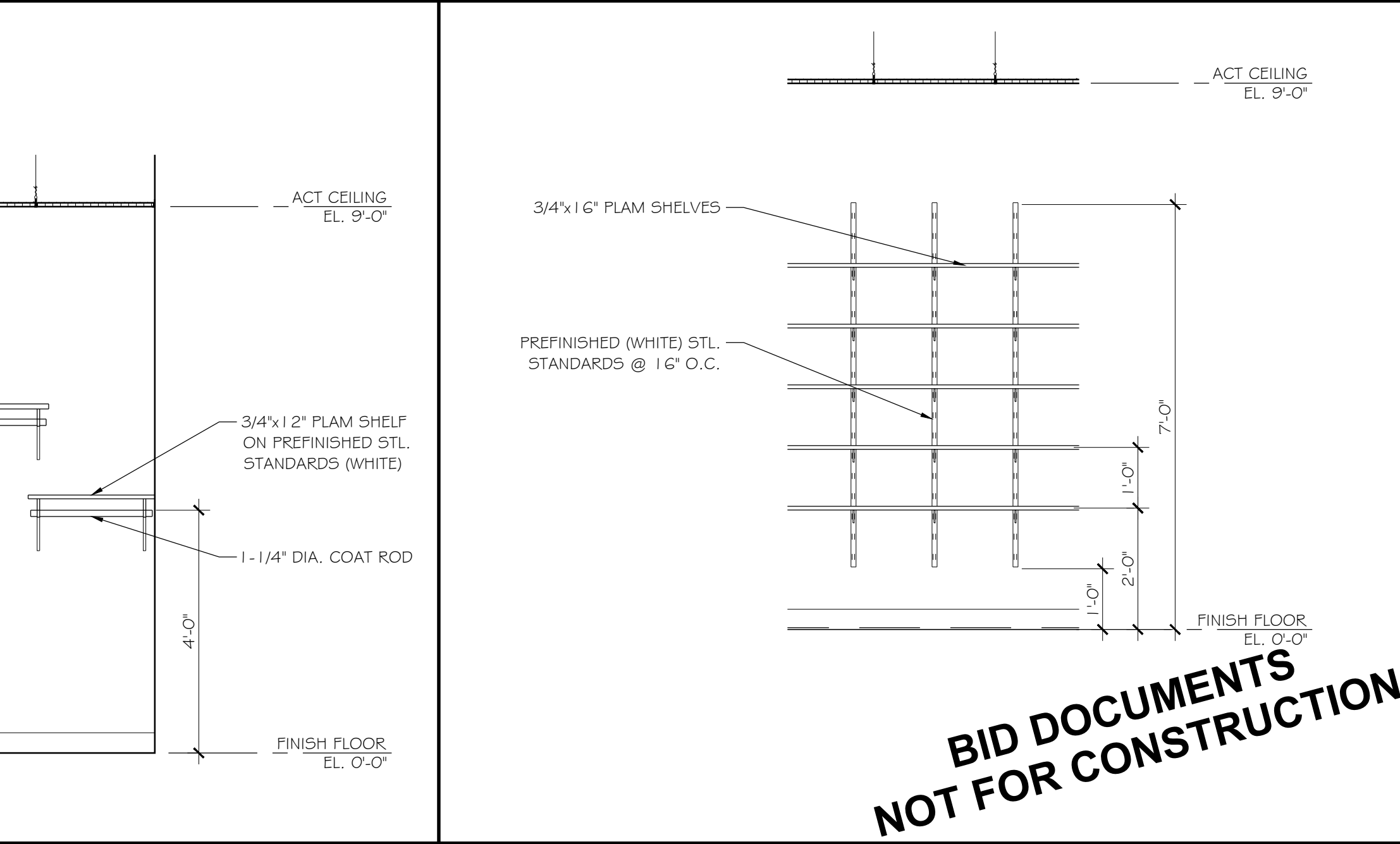
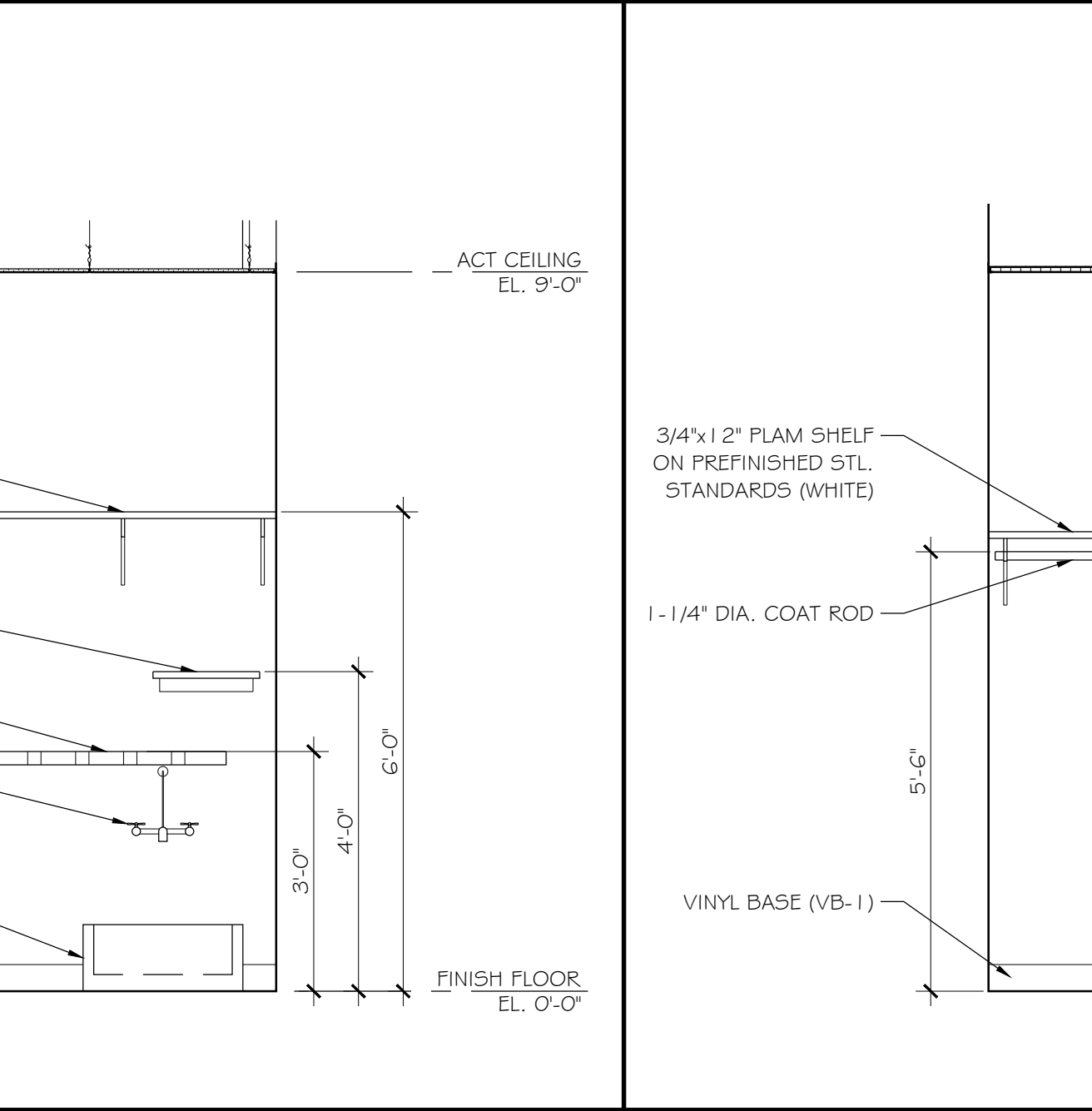
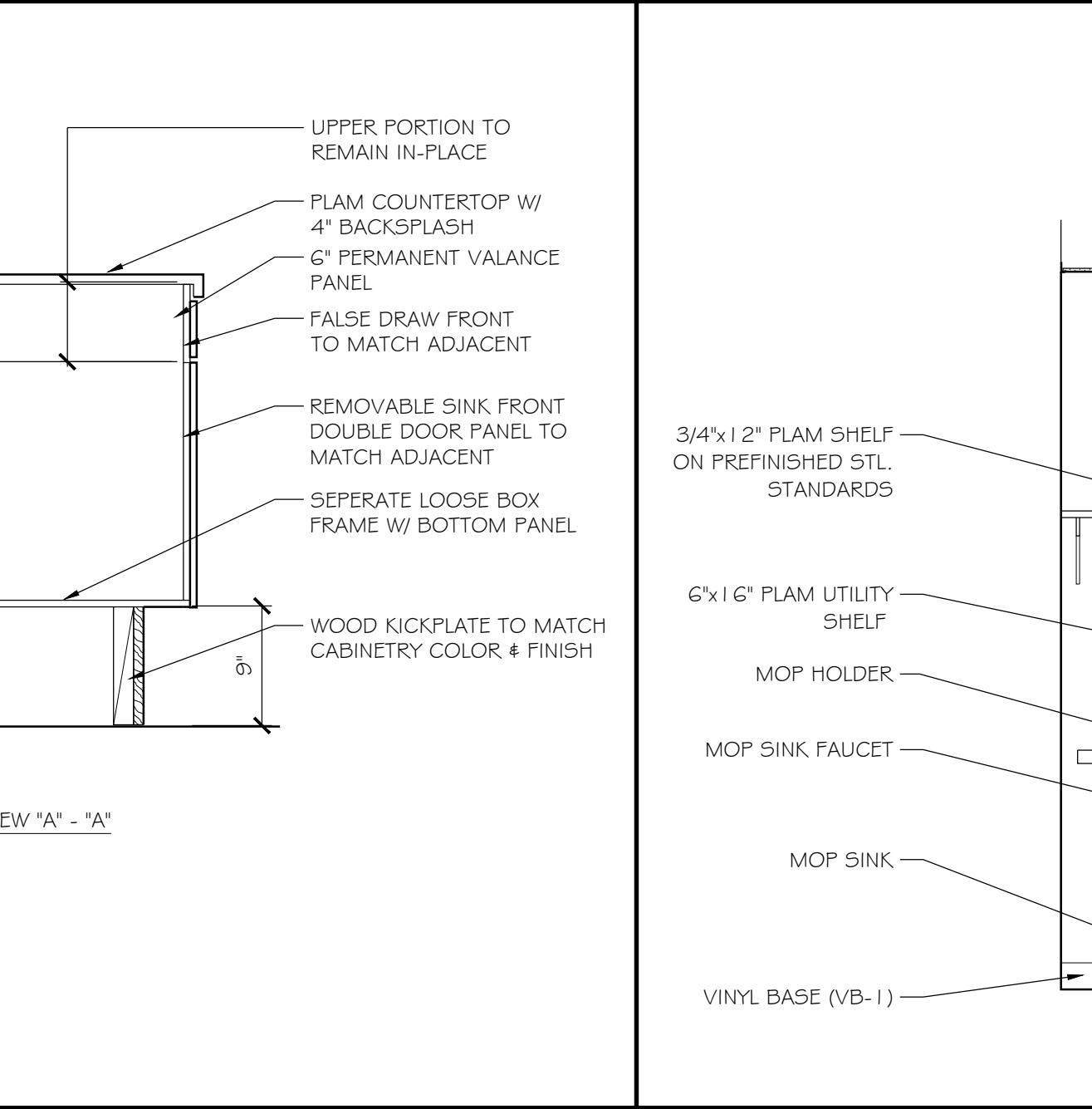
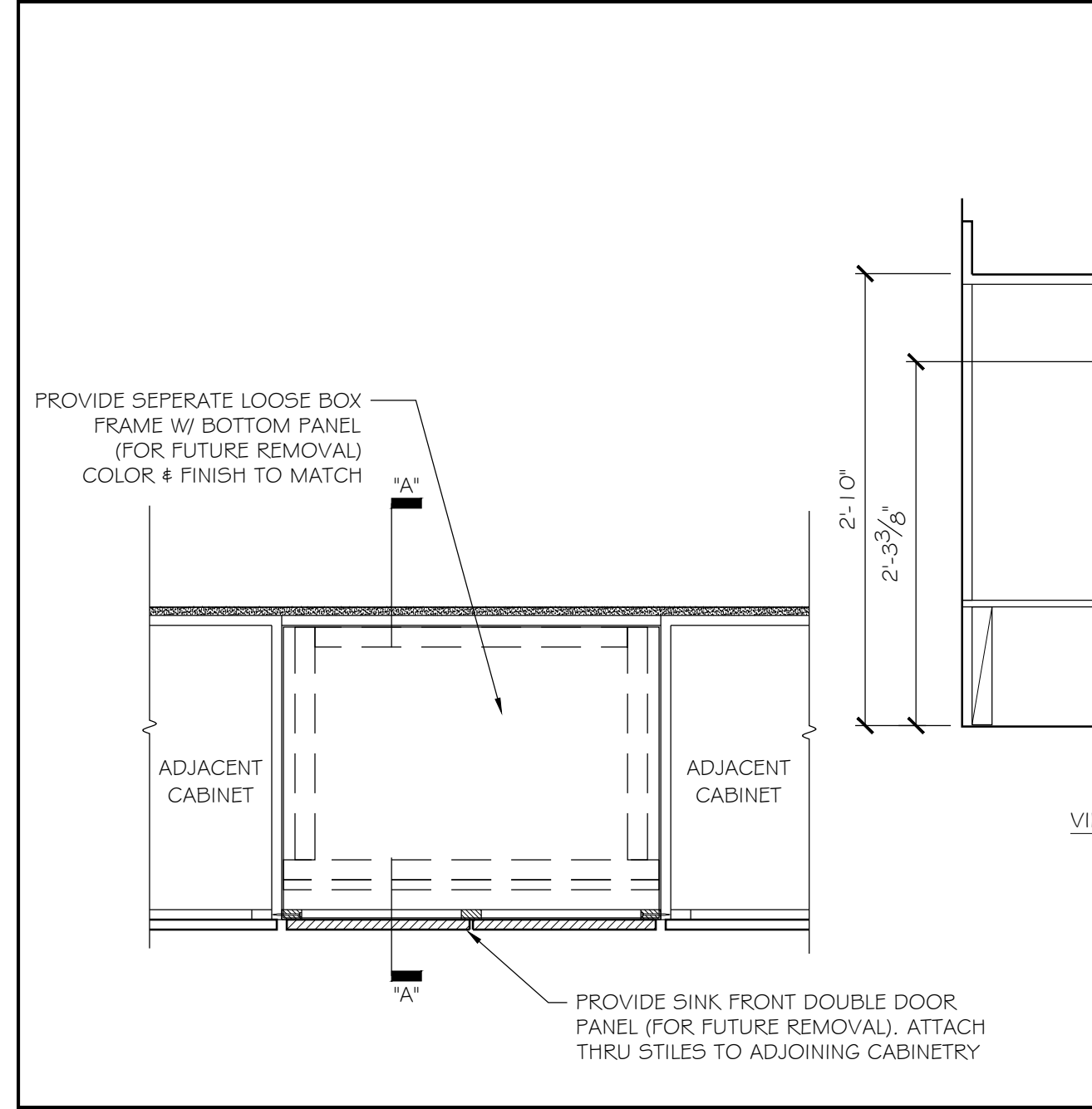

2 COAT ROAD & SHELF DETAIL
 A101-A103 SCALE: 1/2" = 1'-0"

1 SHELVING DETAIL
 A101-A103 SCALE: 1/2" = 1'-0"

3 JANITOR SINK DETAIL
 A101-A103 SCALE: 1/2" = 1'-0"

4 REMOVABLE ADA CABINET BASE DTL.
 A101-A103 SCALE: 1" = 1'-0"

- DRAWING STATUS
- OFFICE REVIEW
 - CLIENT REVIEW
 - PERMIT REVIEW
 - BID SET
 - CONTRACT DRAWING
 - CONSTRUCTION

No drawing shall be recognized as a construction document unless it bears a blue inked registration seal.

SHEET TITLE
INTERIOR DETAILS

JOB NO.
 201512

DRAWN BY
 EBJ

CHECKED BY
 TRN

SCALE
 AS NOTED

ORIGINAL DATE
 09-19-2016

REVISION DATE

SHEET

A611

**BID DOCUMENTS
 NOT FOR CONSTRUCTION**