

PLOT PLAN (EXISTING)

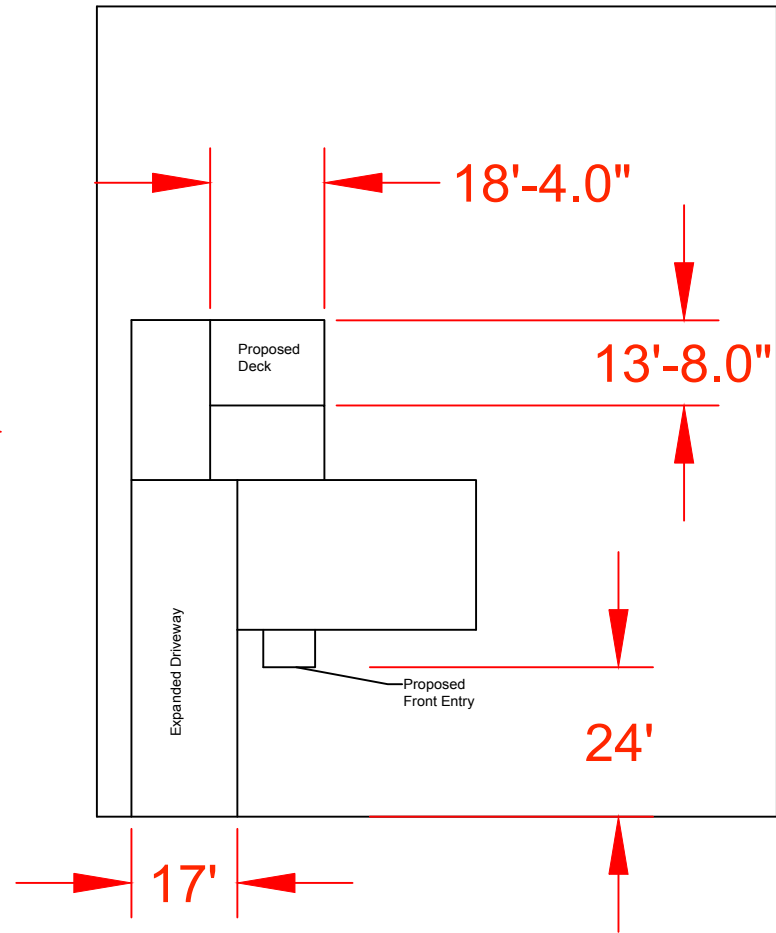

PLOT PLAN (PROPOSED)

SCALE

FRONT ELEVATION (EXISTING)

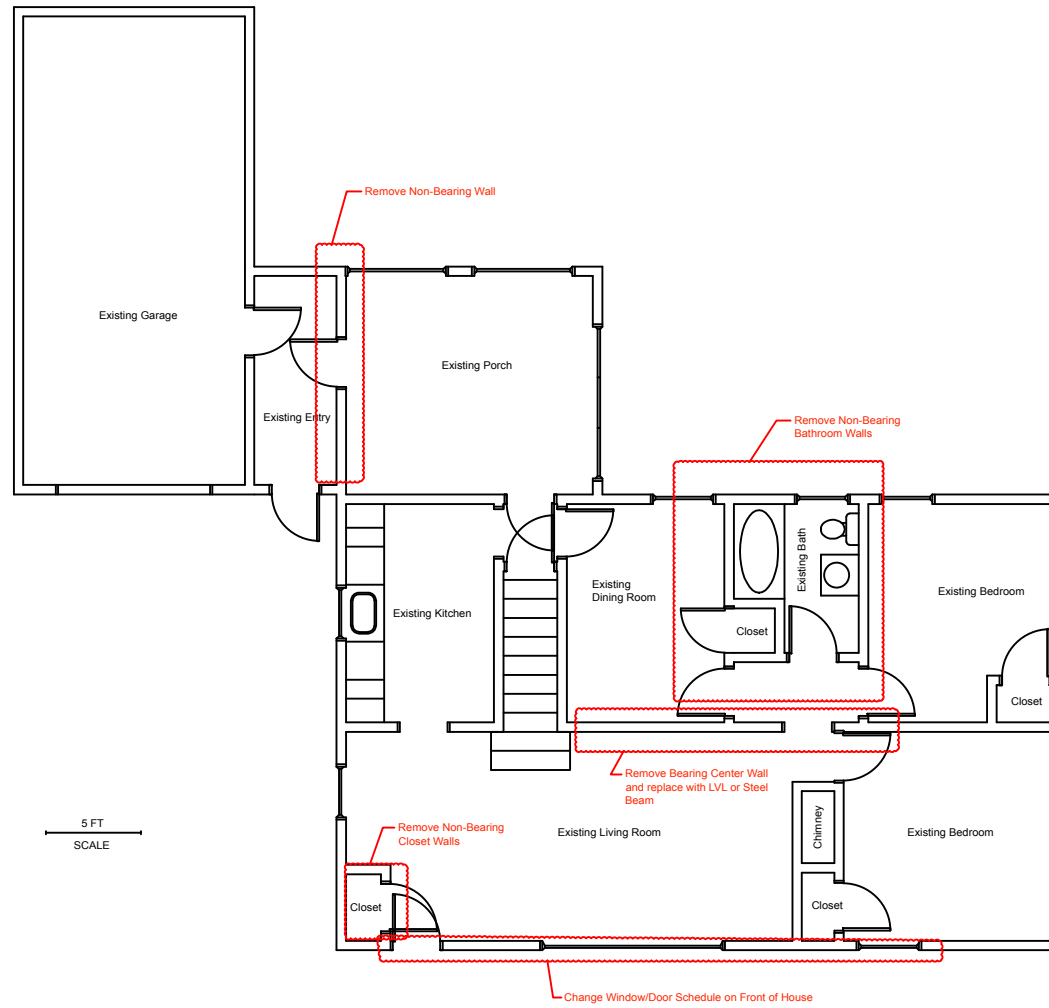

FIRST FLOOR PLAN VIEW (EXISTING)

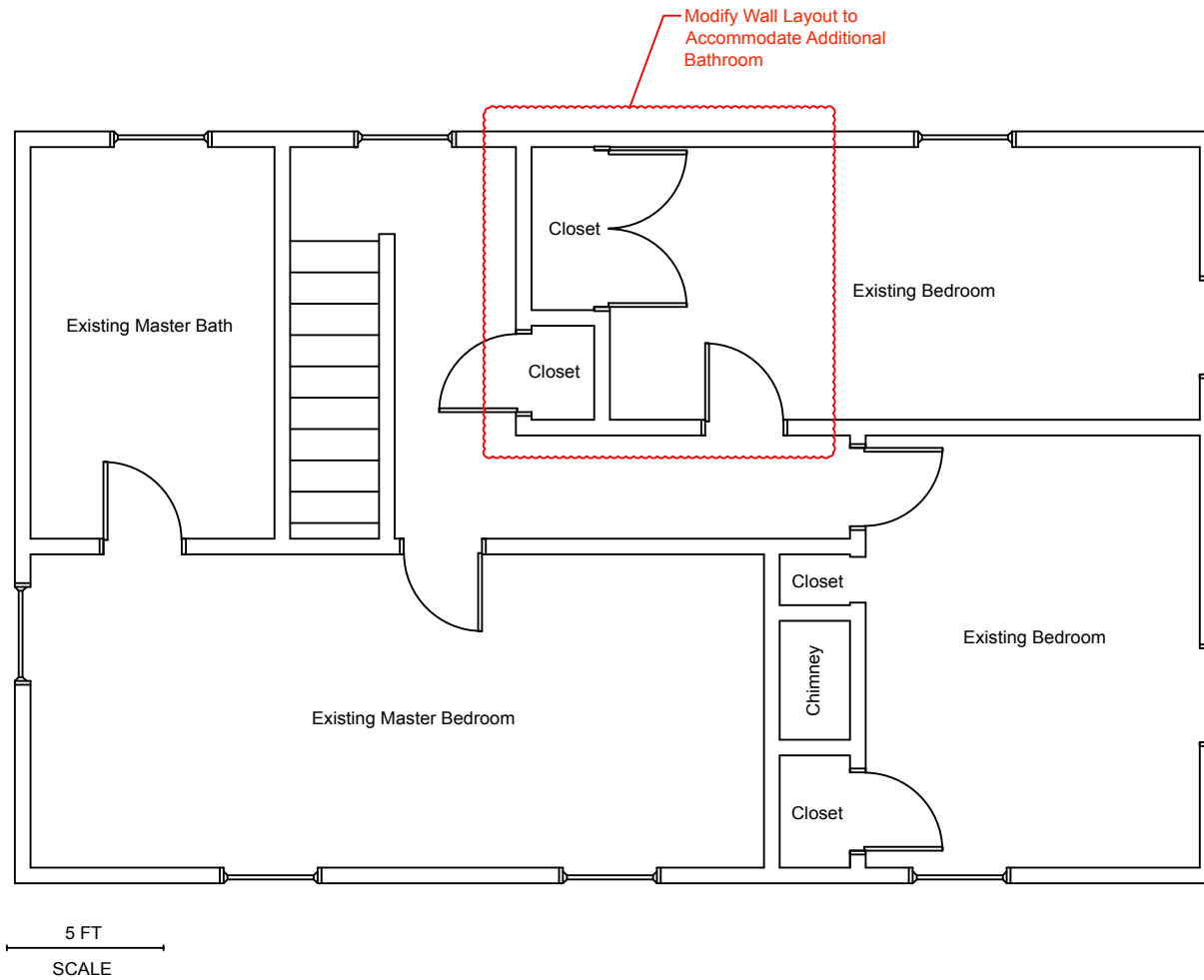

SECOND FLOOR PLAN VIEW (EXISTING)

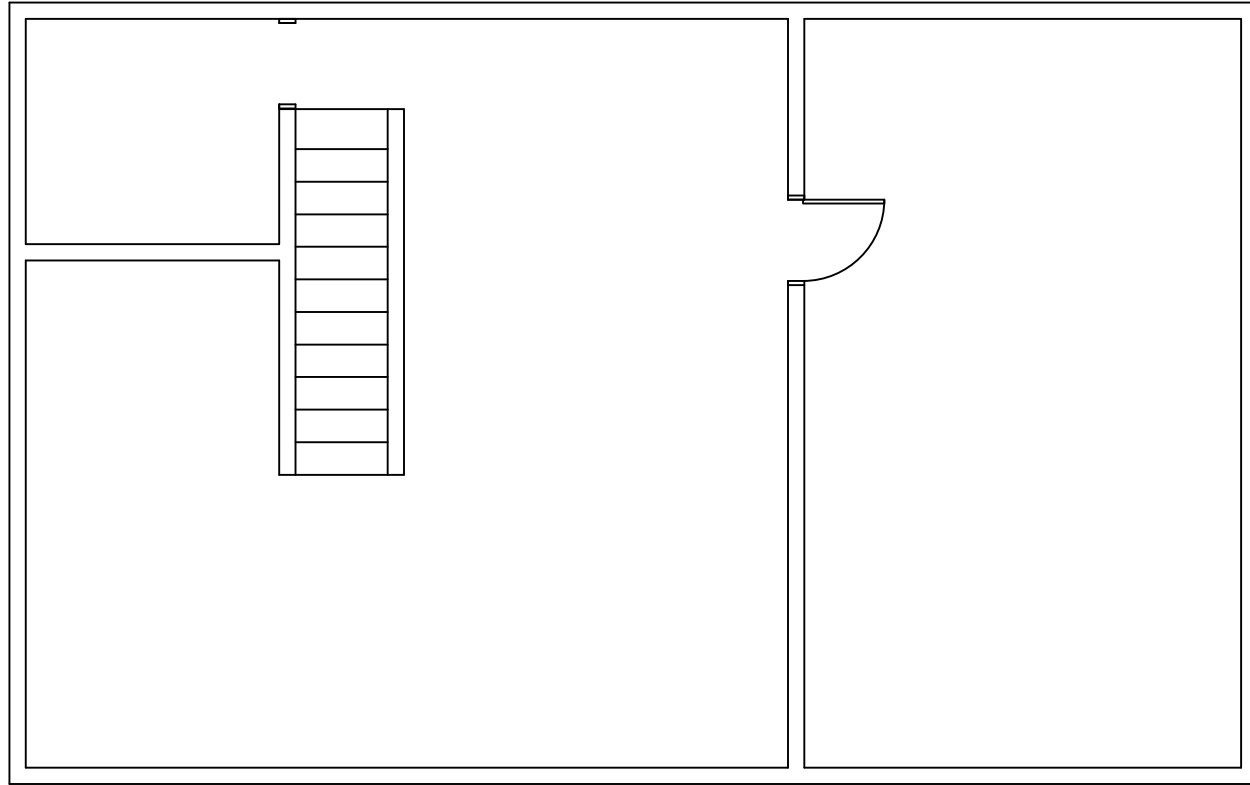

5 FT
SCALE

BASEMENT PLAN VIEW (EXISTING)

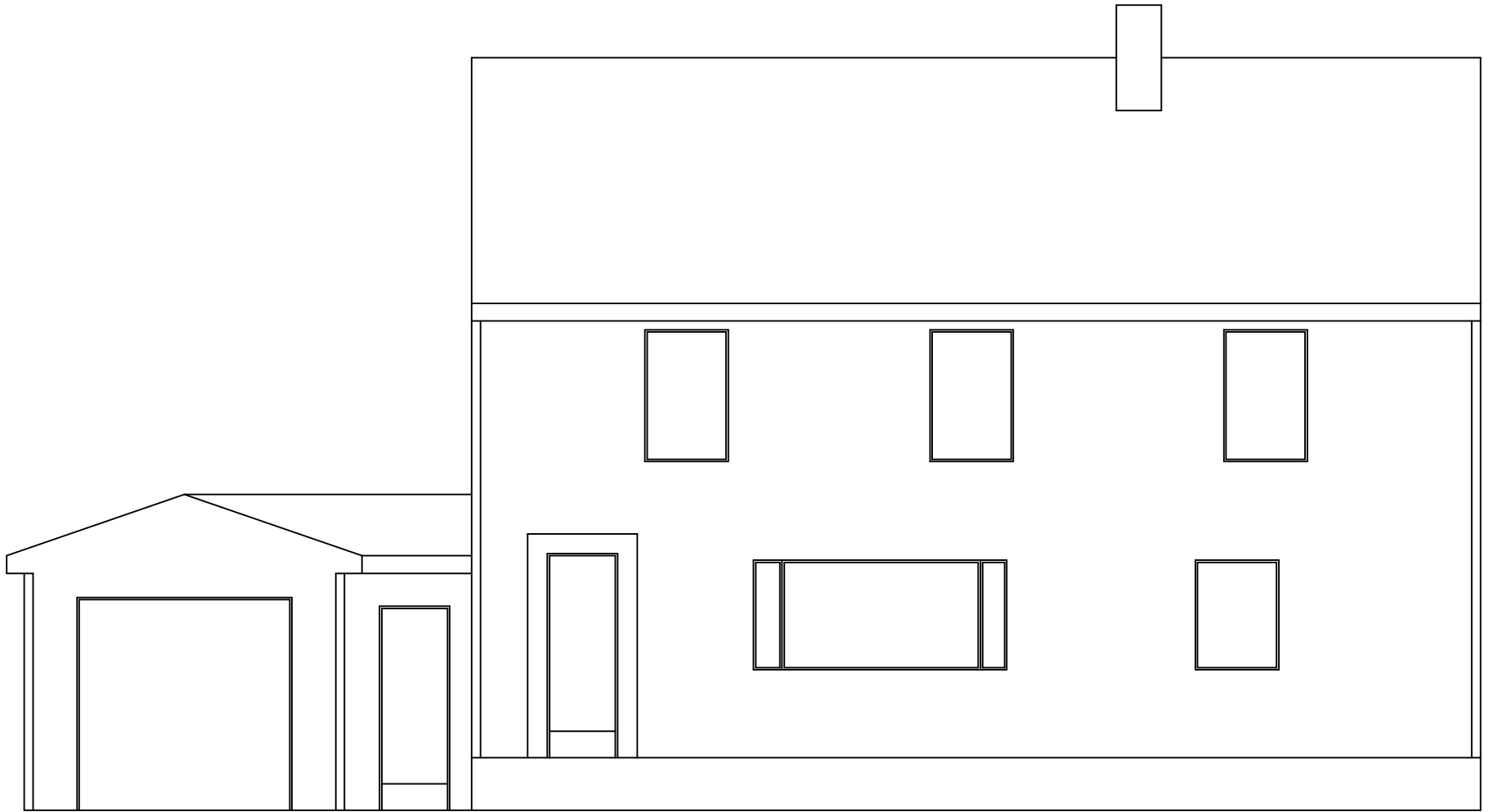

5 FT
SCALE

FRONT ELEVATION (EXISTING)

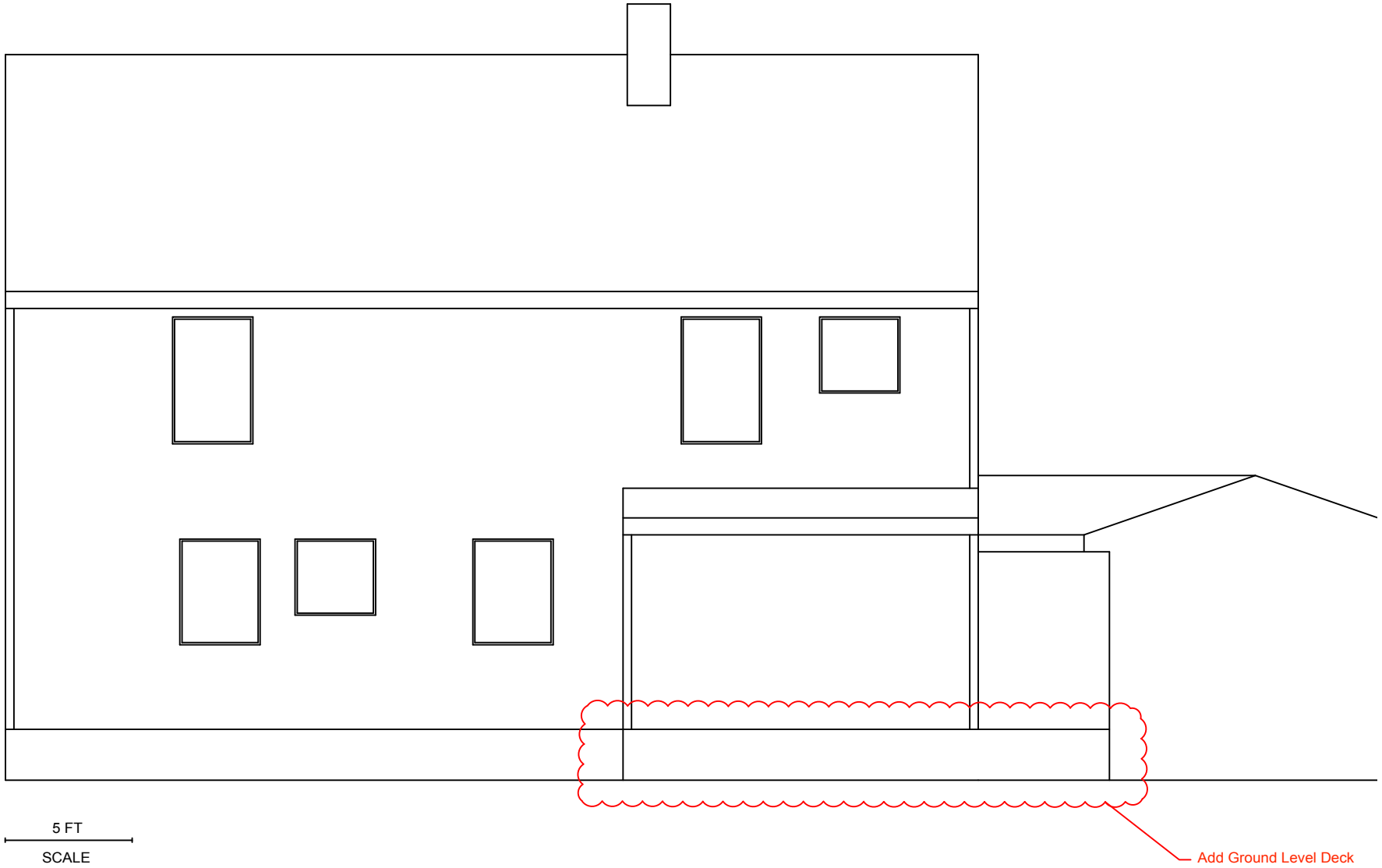

5 FT
SCALE

BACK ELEVATION (EXISTING)

Add Ground Level Deck

18'-4.0"

13'-8.0"

PORTCH FRAMING DETAIL

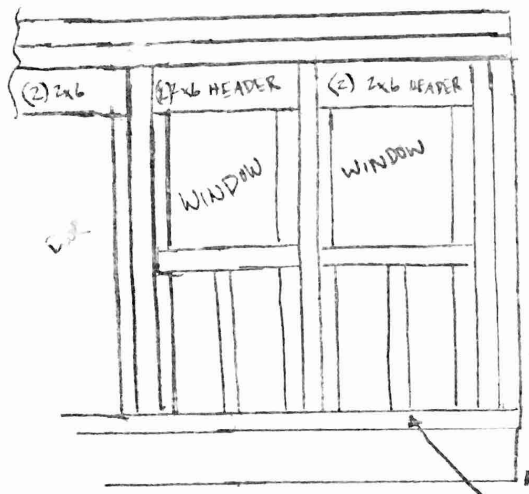

EXISTING CARRYING BEAM

STUDS SPACED 16" OC

- NOTE:
- EXISTING PORCH FRAMING 2x4" CONSTRUCTION
 - ADDITIONAL FRAMING REQUIRED (AS SHOWN ABOVE) FOR ADDITION OF DOOR AND REPLACEMENT WINDOWS

5 FT SCALE

CO2/SMOKE

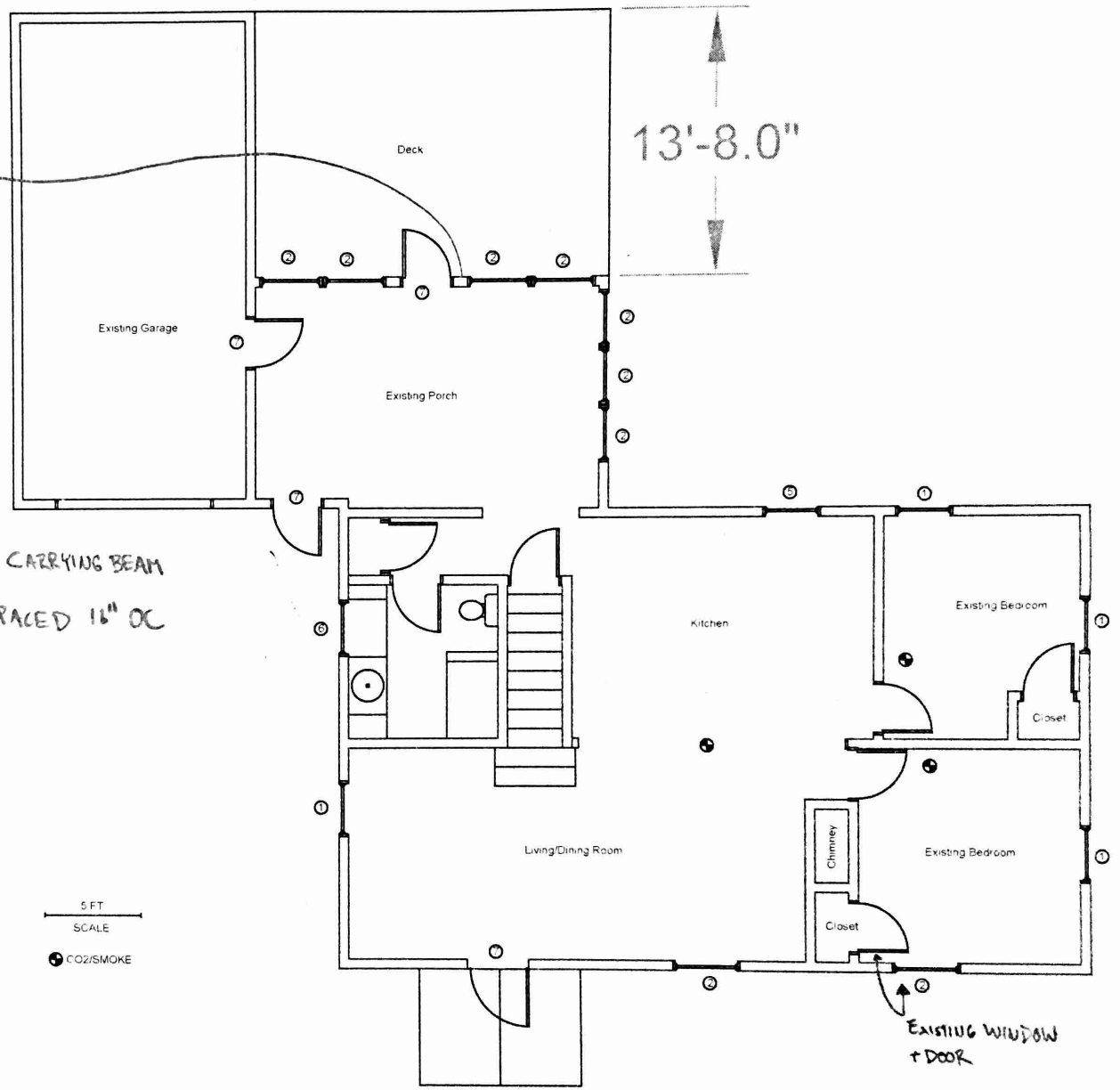

EXISTING WINDOW + DOOR

FIRST FLOOR PLAN VIEW (PROPOSED)

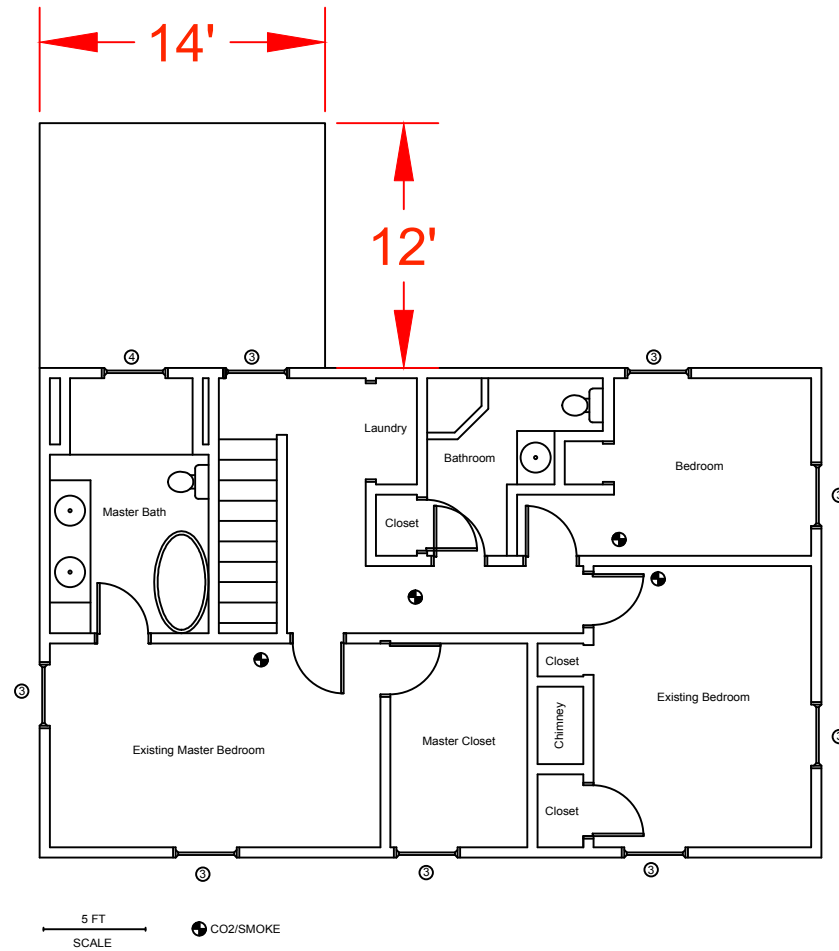

SECOND FLOOR PLAN VIEW (PROPOSED)

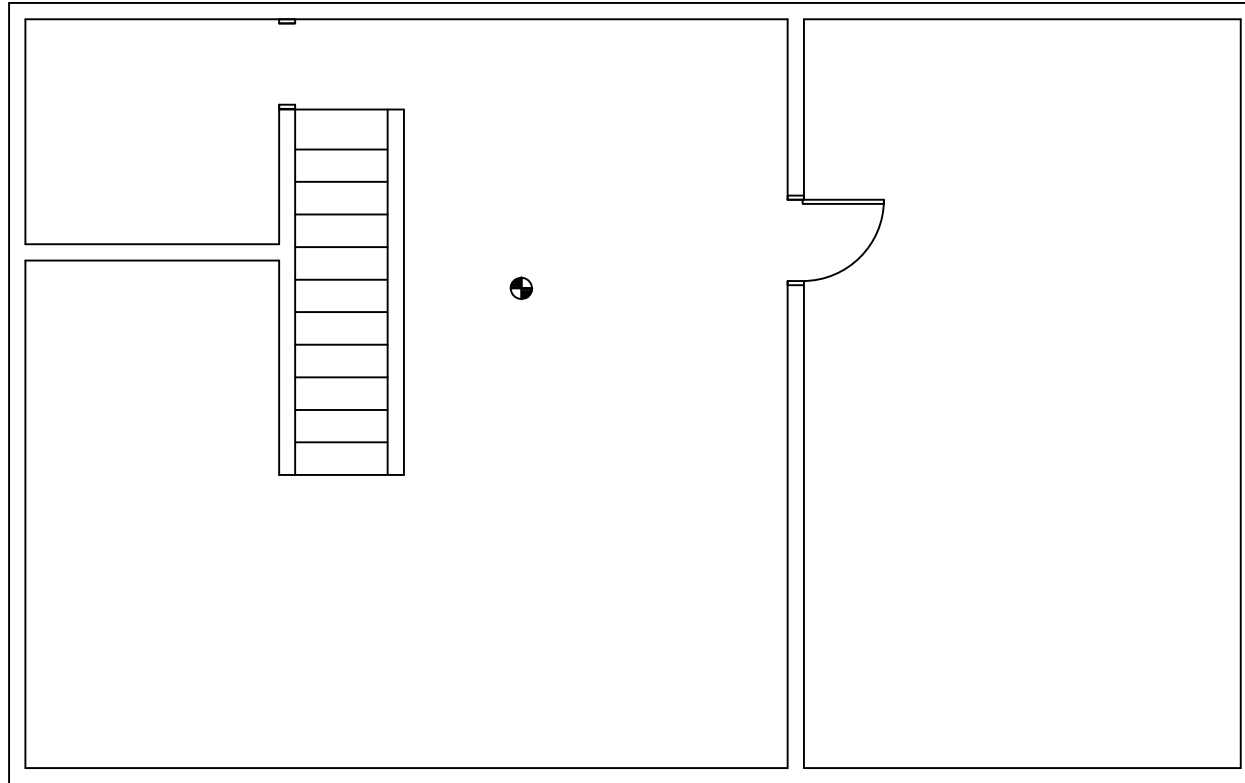

5 FT
SCALE

⊕ CO2/SMOKE

BASEMENT PLAN VIEW (PROPOSED)



5 FT
SCALE

FRONT ELEVATION (PROPOSED)

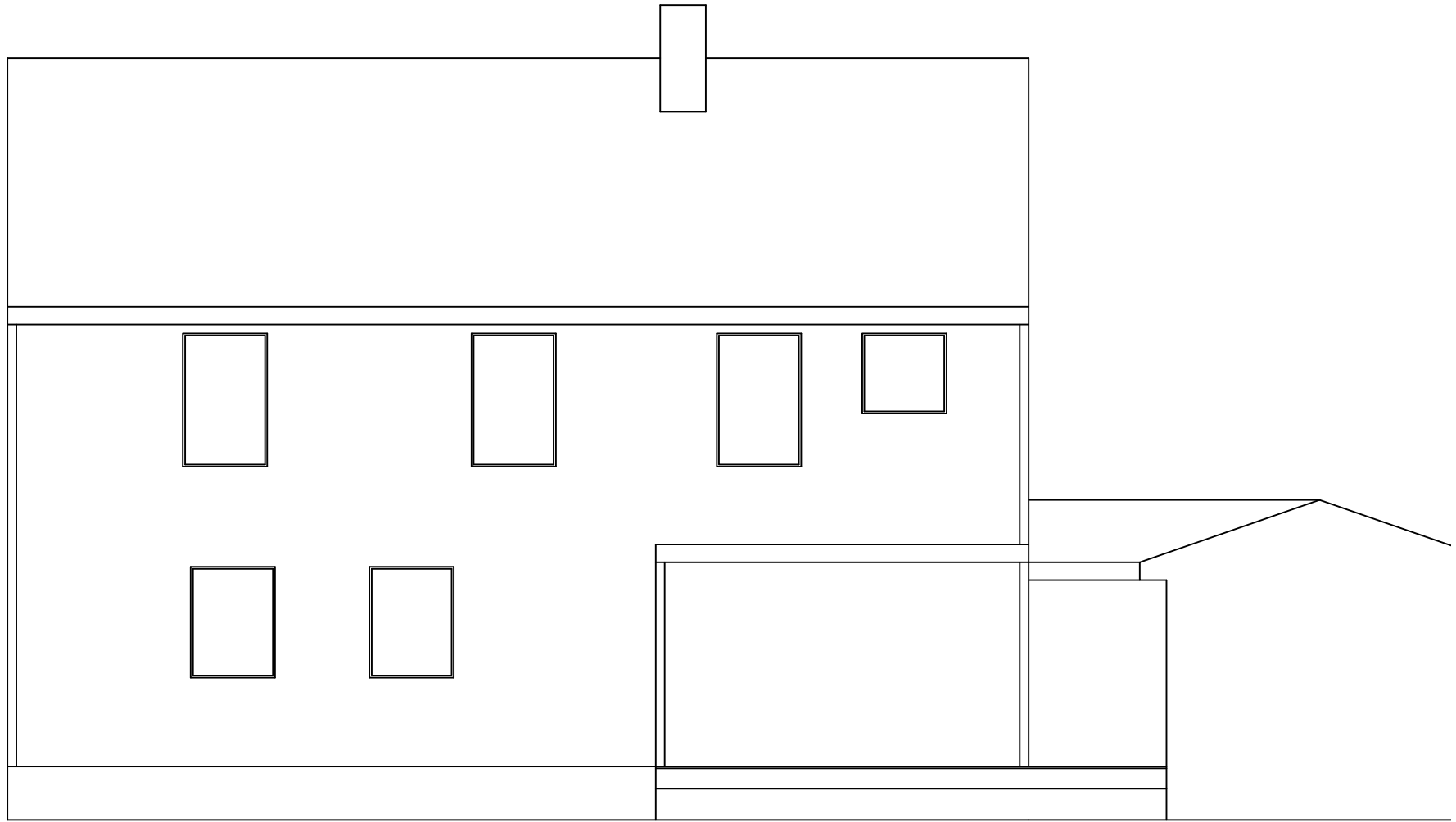

5 FT
SCALE

BACK ELEVATION (PROPOSED)

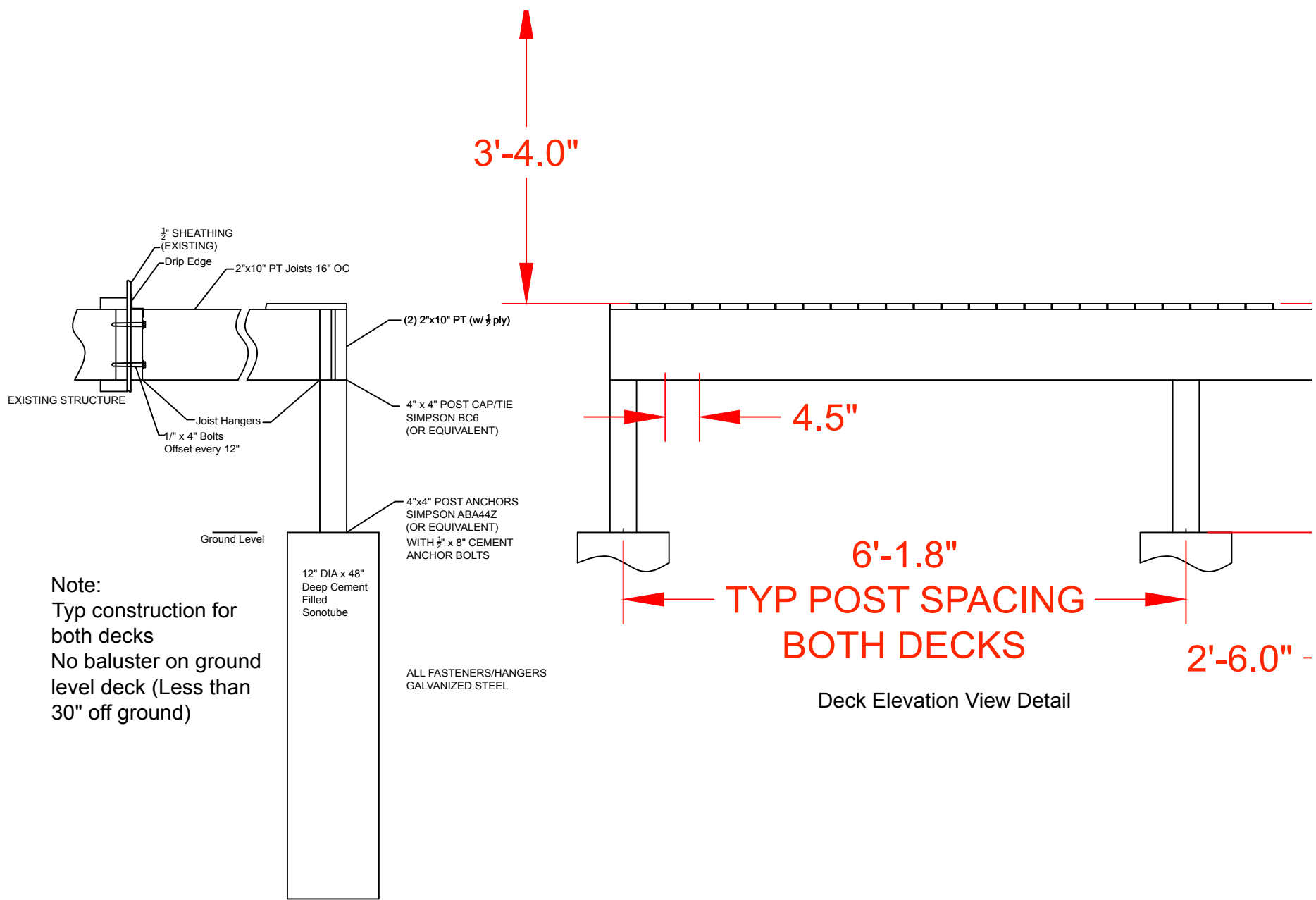

Note:
 Typ construction for both decks
 No baluster on ground level deck (Less than 30" off ground)

Deck Elevation View Detail

Deck Side View Detail 1
 (Connection to Existing House Structure)

1 FT
 SCALE

1ST STORY SUPPORT BEAM

STEEL BEAM ATTACHMENT DETAIL

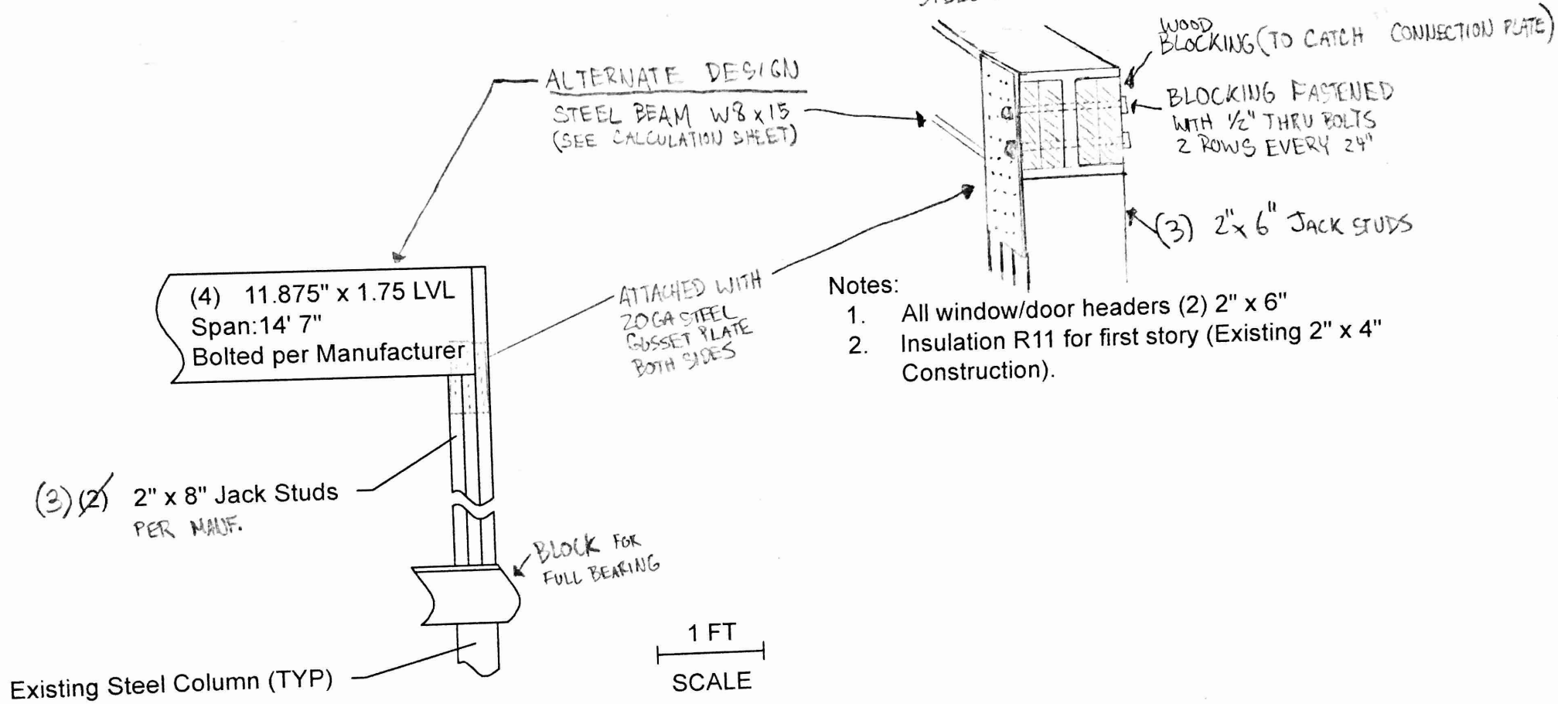

FRONT ENTRANCE DETAIL

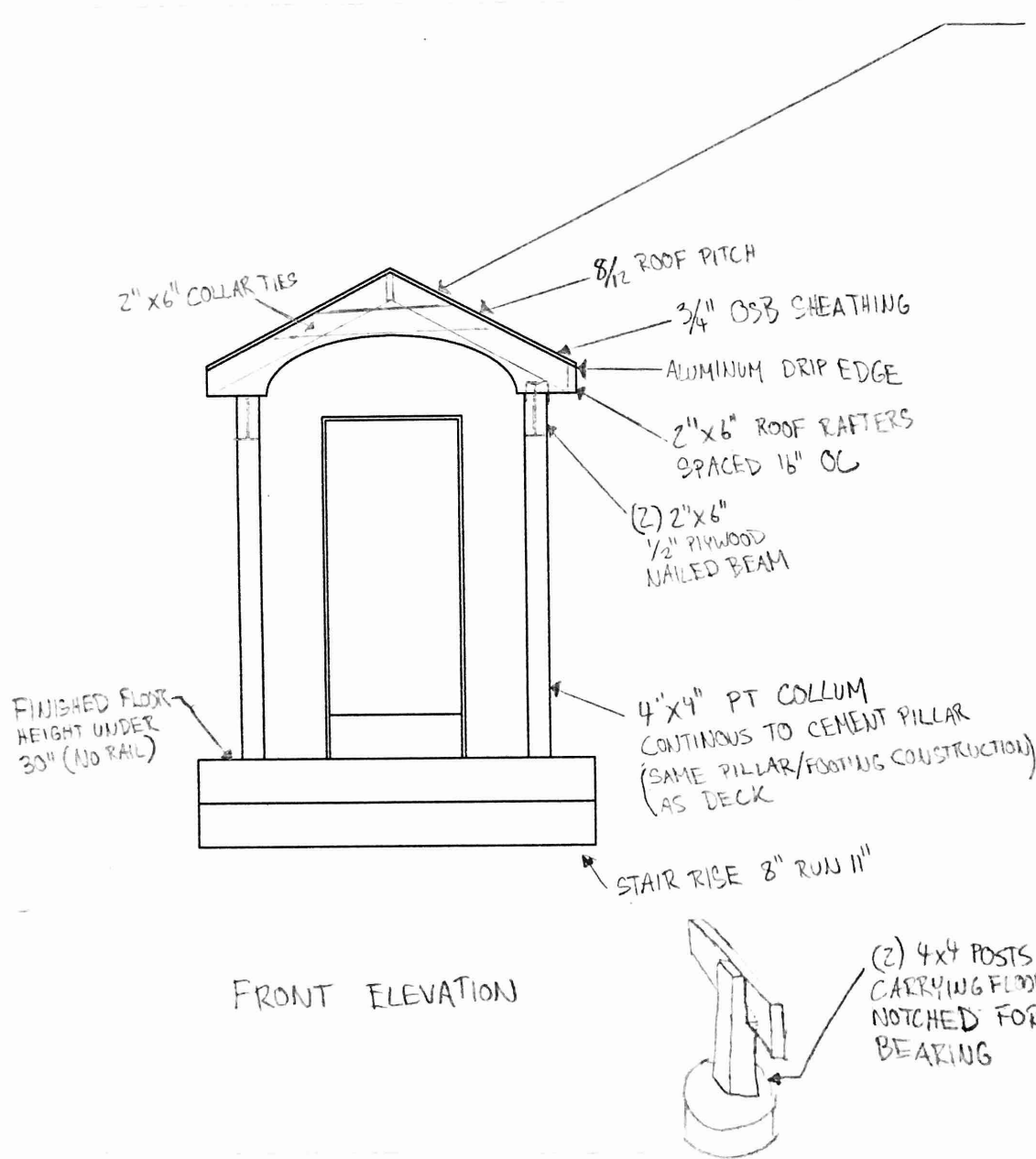

ROOF COVERING NOTES

- ICE + WATER SHIELD ALONG LOWER ROOF LINE AND SEAMS
- 3 TAB ASPHALT SHINGLE
- ROOF RAFTER/LEDGER ABUTTING HOUSE SHEATHING NAILED TO INTER FLOOR JOISTS/STUDS WITH 3" RING NAILS

LEDGER ATTACHED/FLASHED AS SHOWN IN BACK DECK DETAIL

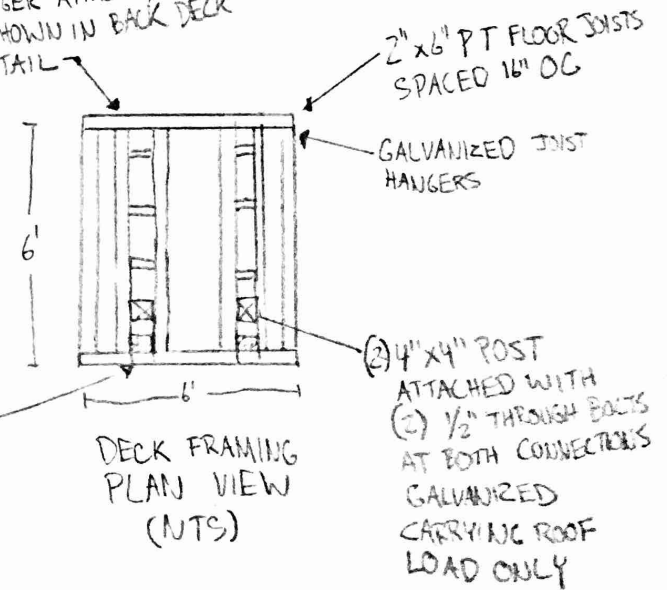

FRONT ENTERANCE DETAIL

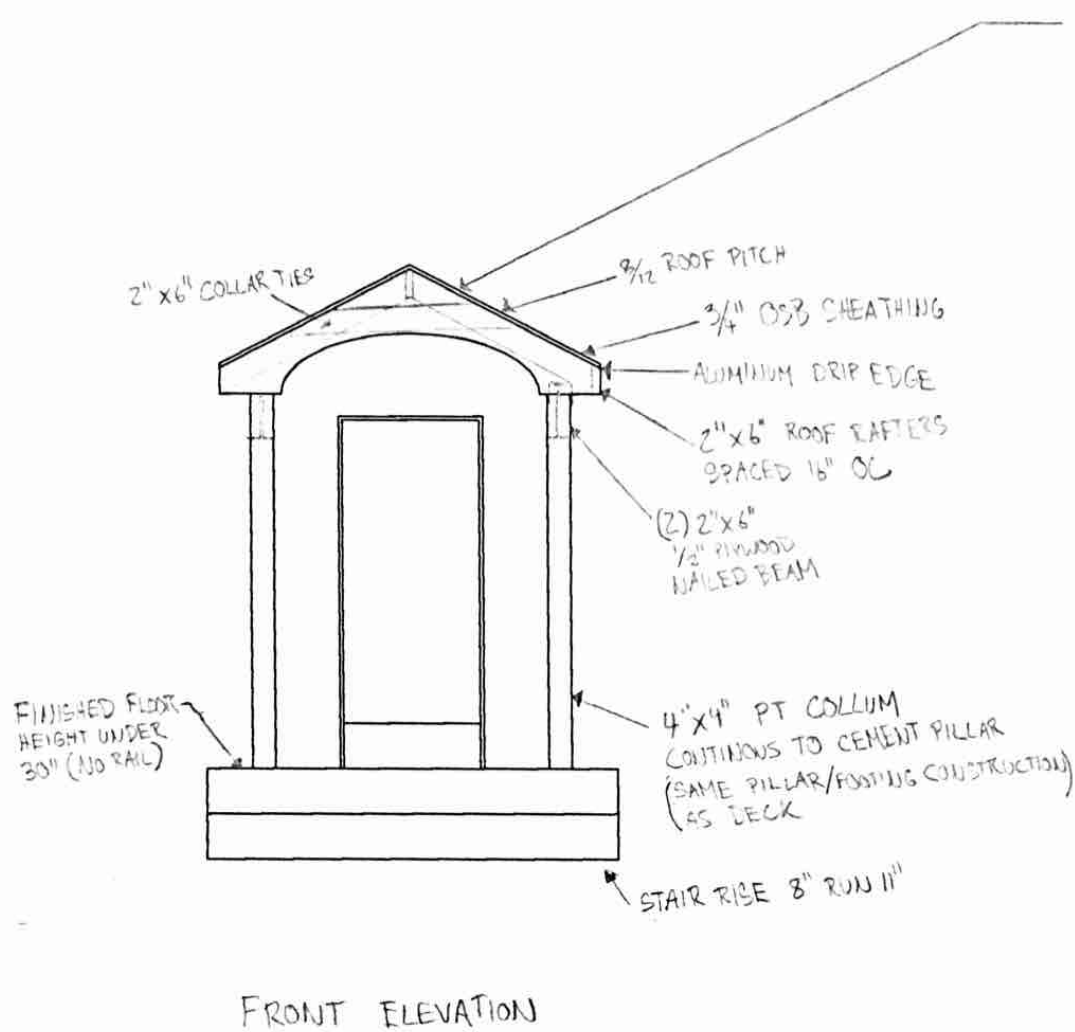

ROOF COVERING NOTES

- ICE + WATER SHIELD ALONG LOWER ROOF LINE AND SEAMS
- 3 TAB ASPHALT SHINGLE
- ROOF RAFTER/LEDGER ABUTTING HOUSE SHEATHING NAILED TO INTER FLOOR JOIST/STUDS WITH 3" RING NAILS

LEDGER ATTACHED/FLASHED AS SHOWN IN BACK DECK DETAIL

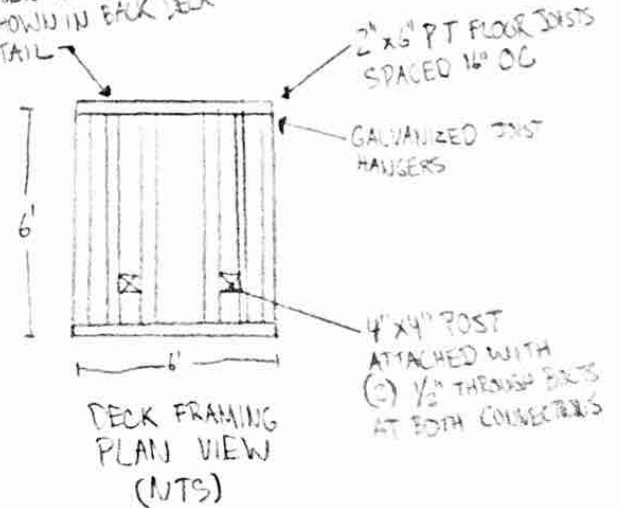

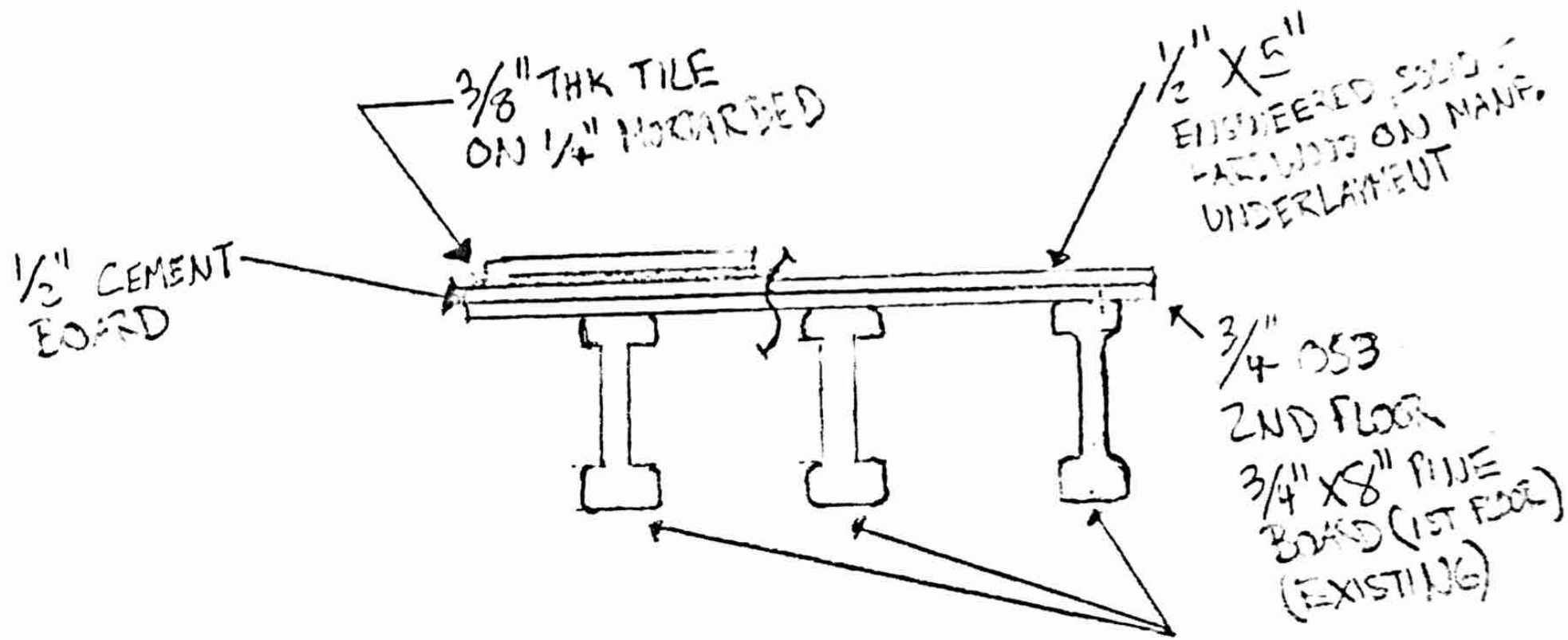

1/2" CEMENT BOARD

3/8" THK TILE ON 1/4" MORTAR BED

1/2" X 6" ENGINEERED SOLID HARDWOOD ON MANF. UNDERLAYMENT

3/4" OSB
2ND FLOOR
3/4" X 8" PINE BOARD (1ST FLOOR) (EXISTING)

FLOOR DETAIL

3" x 10" ENGINEERED COMPOSITE I-BEAM JOISTS 16" O.C (EXISTING)

Window and Door Schedule

Indicator	Size (H"xW")	Height (floor to sill)	Type	
1	46 x 30	32	Double Hung	Existing
2	56 x 30	24	Double Hung	Proposed
3	56 x 30	24	Double Hung	Existing
4	36 x 32	46	Double Hung	Existing
5	36 x 32	42	Double Hung	Proposed
6	36 x 30	42	Double Hung	Existing
7	80 x 36	N/A	Single Hinge	Replacement