

PLOT PLAN (EXISTING)

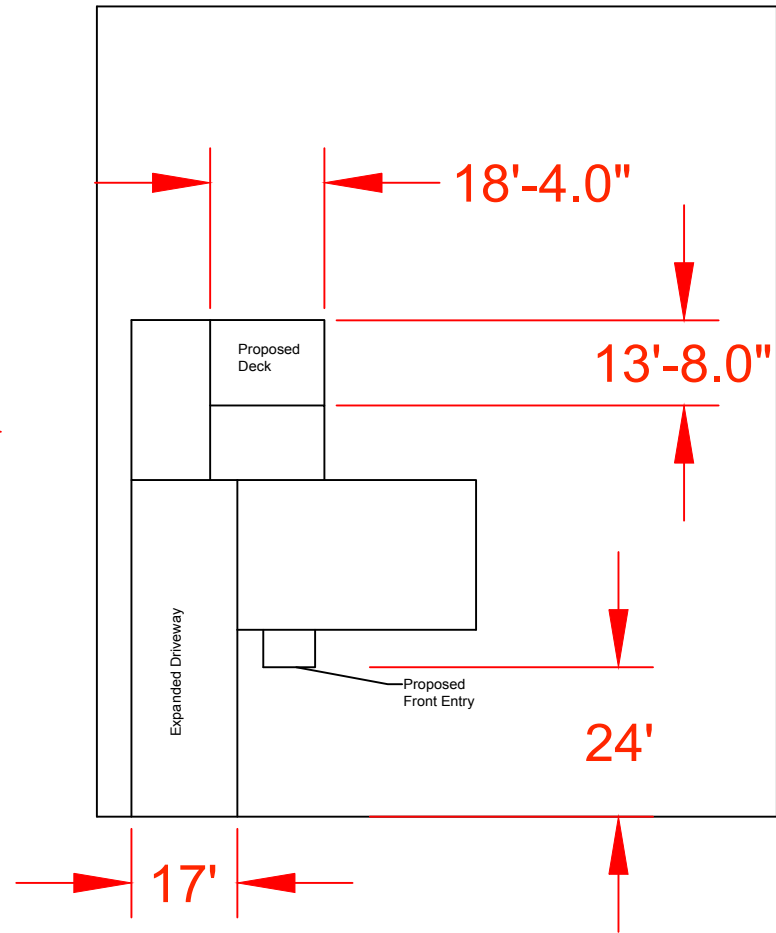

PLOT PLAN (PROPOSED)

SCALE

FRONT ELEVATION (EXISTING)

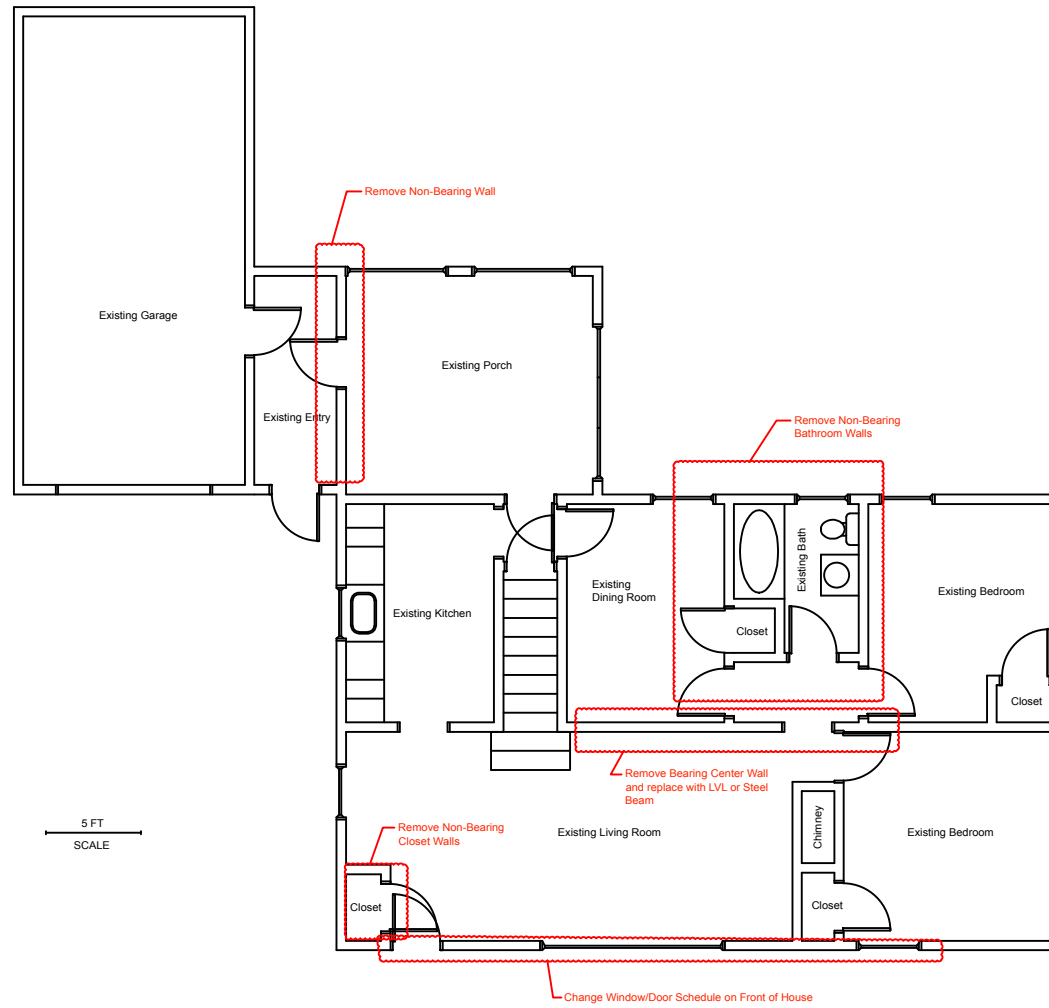

FIRST FLOOR PLAN VIEW (EXISTING)

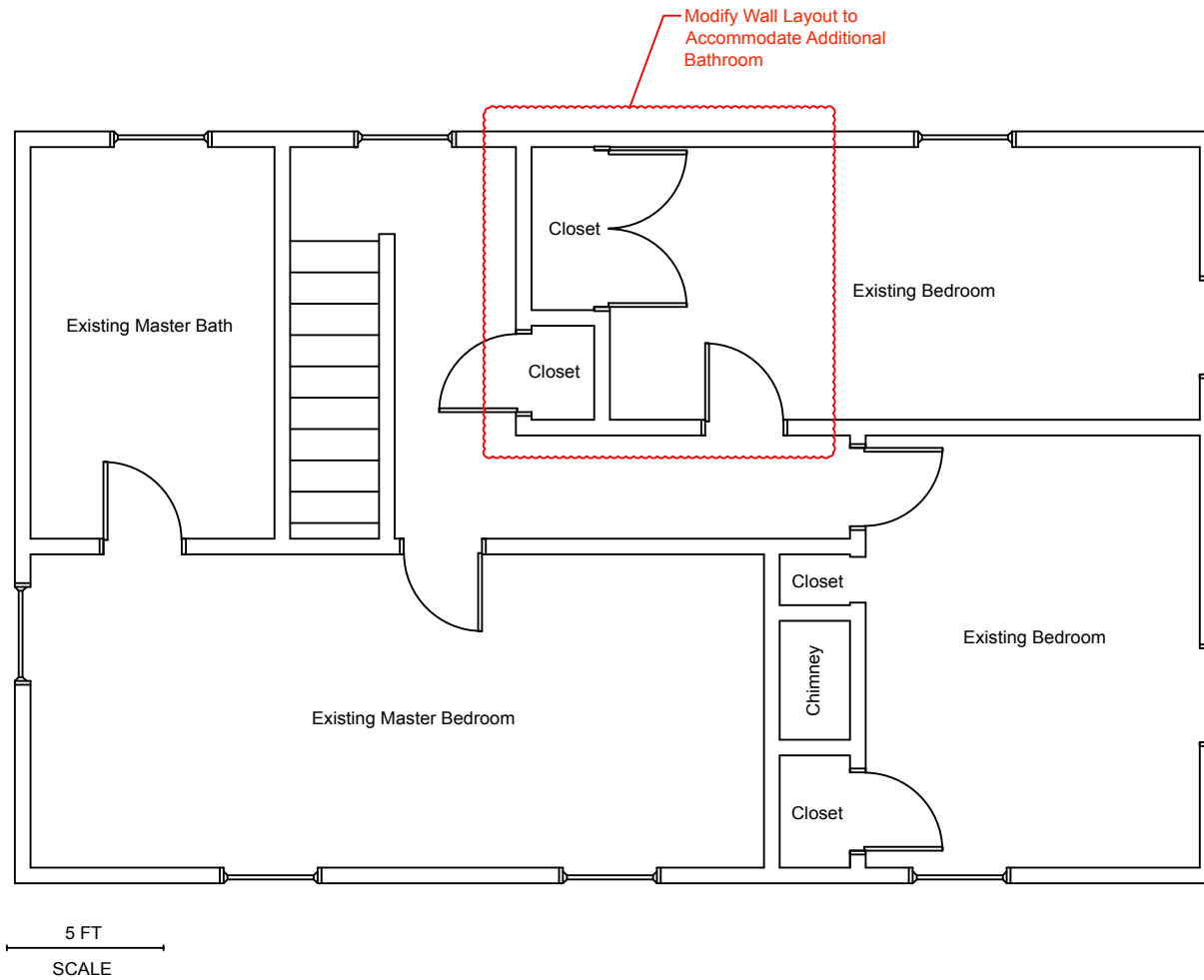

SECOND FLOOR PLAN VIEW (EXISTING)

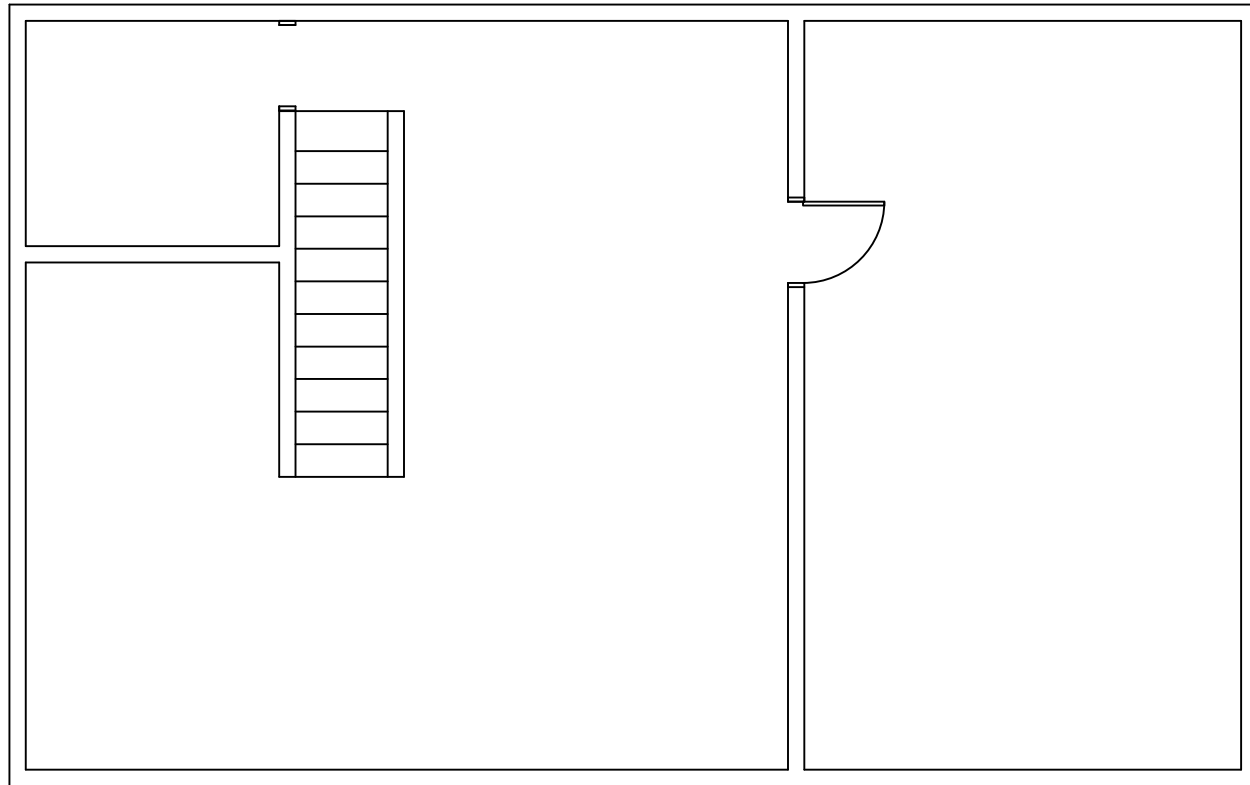

5 FT
SCALE

BASEMENT PLAN VIEW (EXISTING)

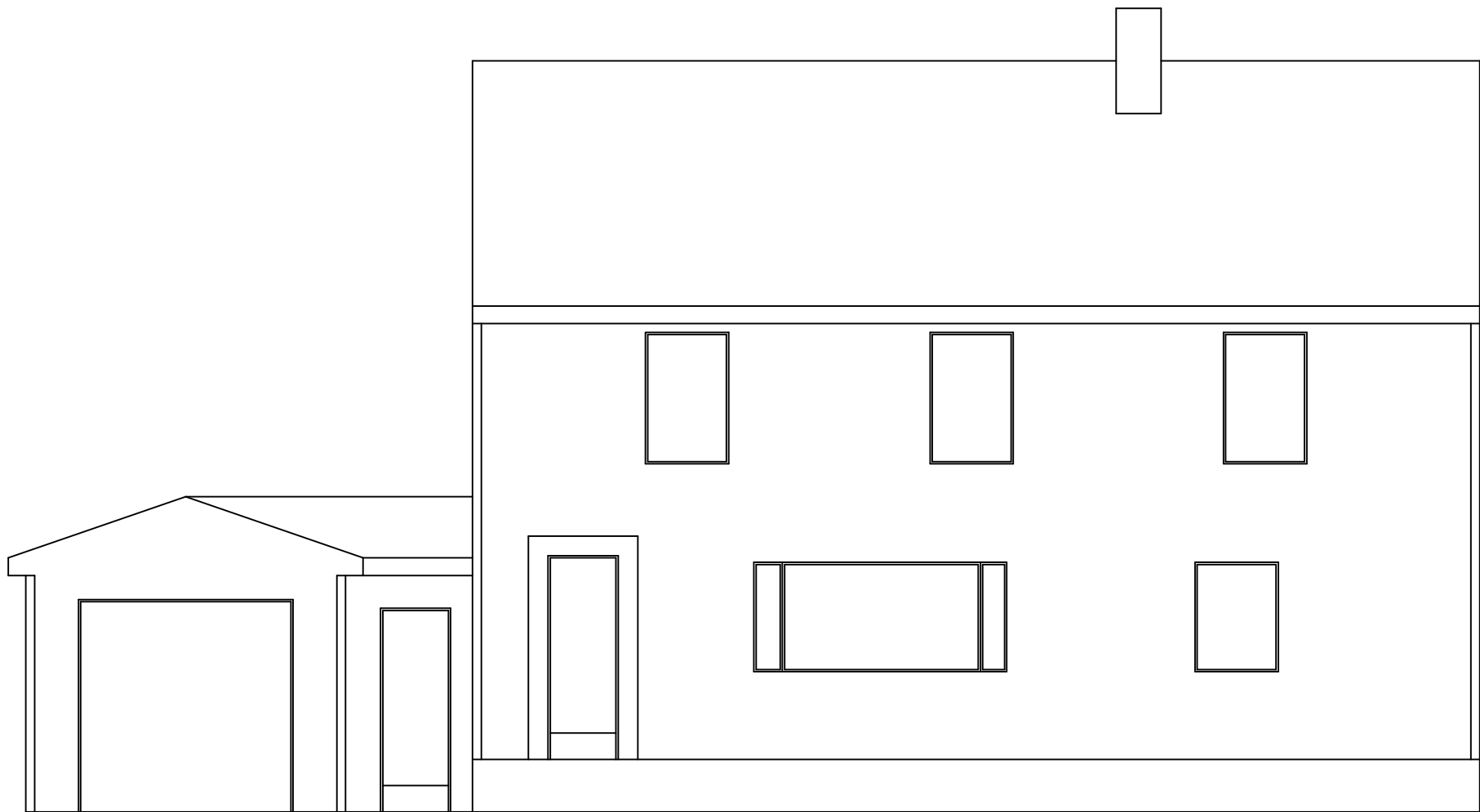

5 FT
SCALE

FRONT ELEVATION (EXISTING)

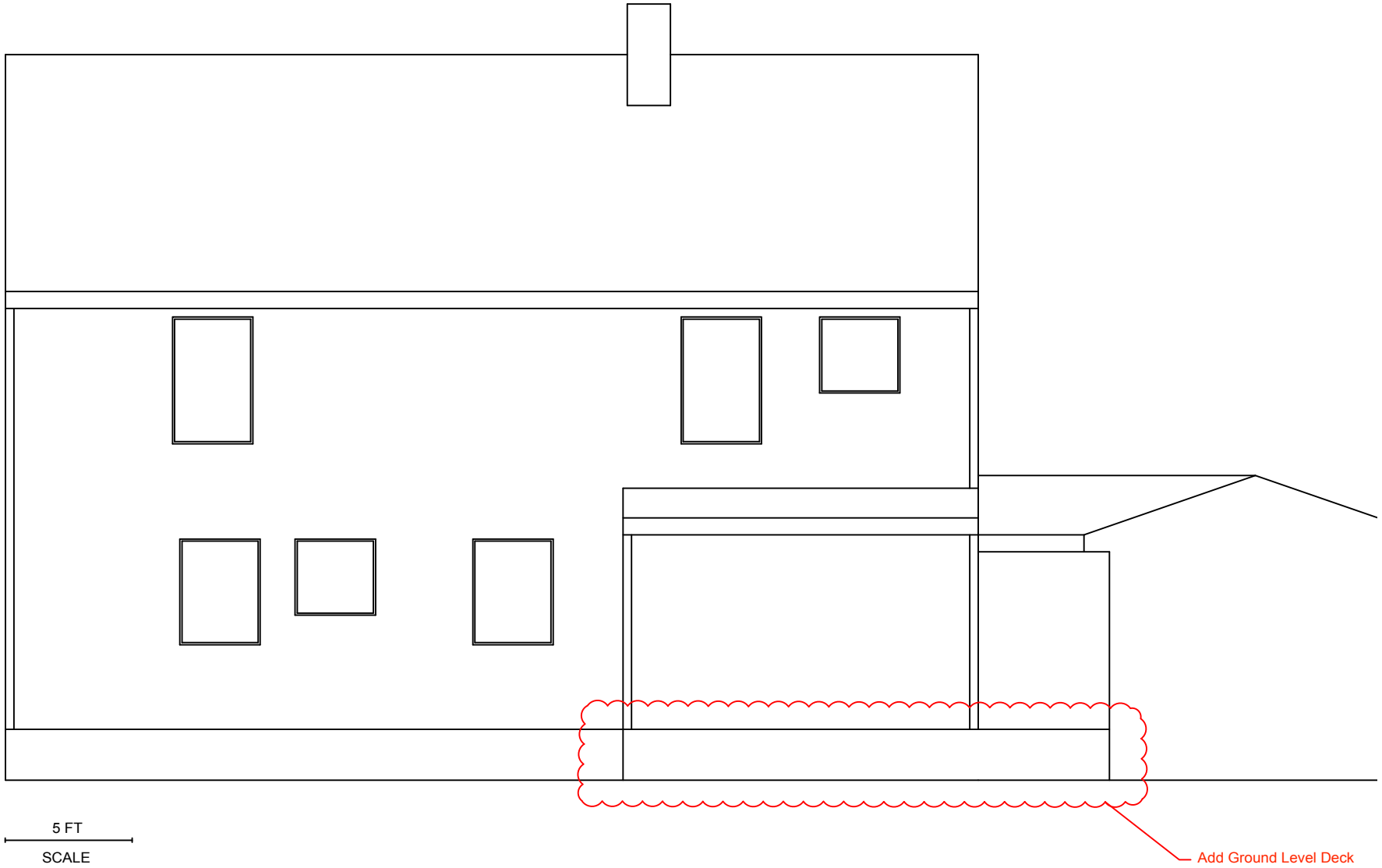

BACK ELEVATION (EXISTING)

Add Ground Level Deck

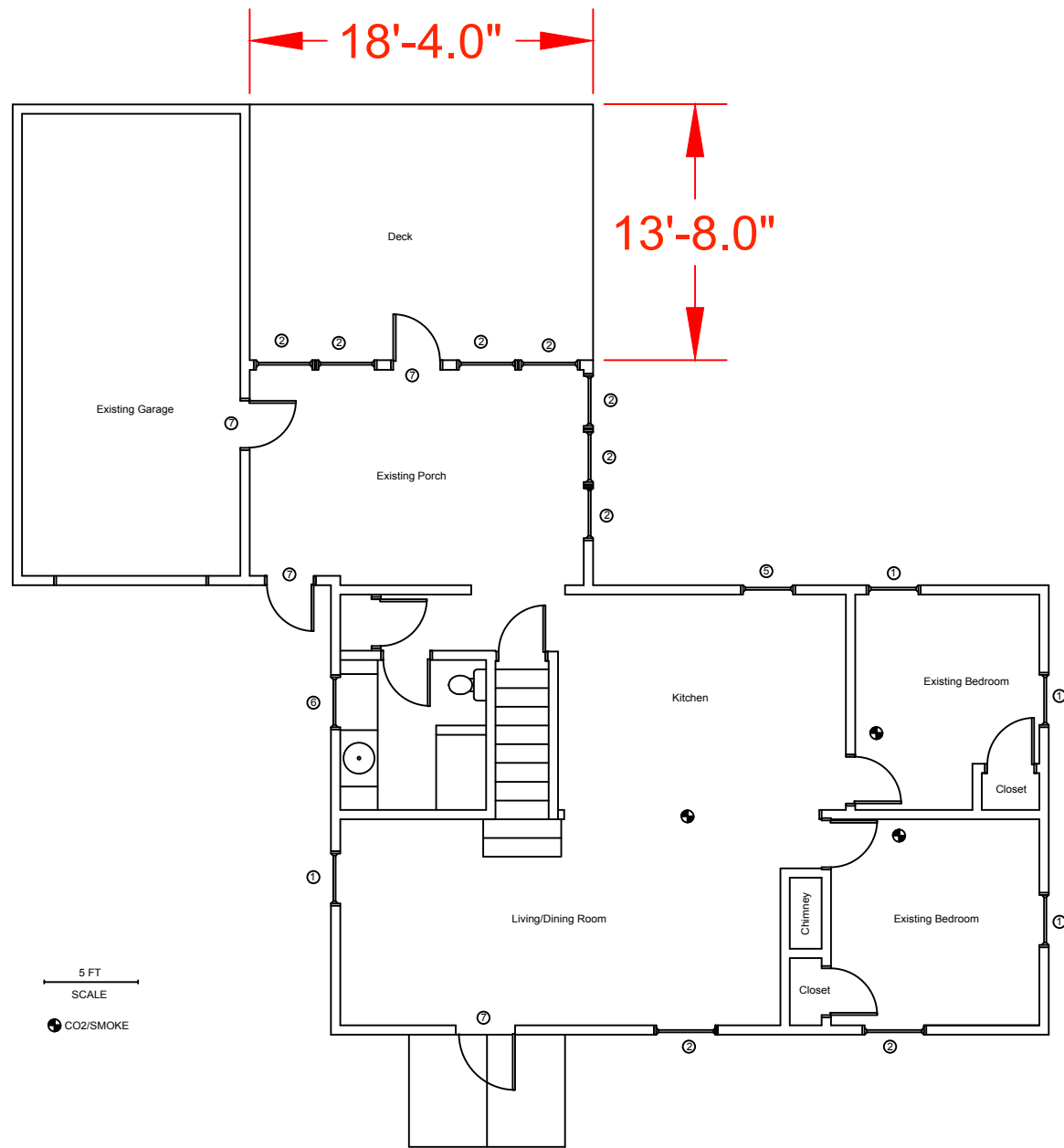

FIRST FLOOR PLAN VIEW (PROPOSED)

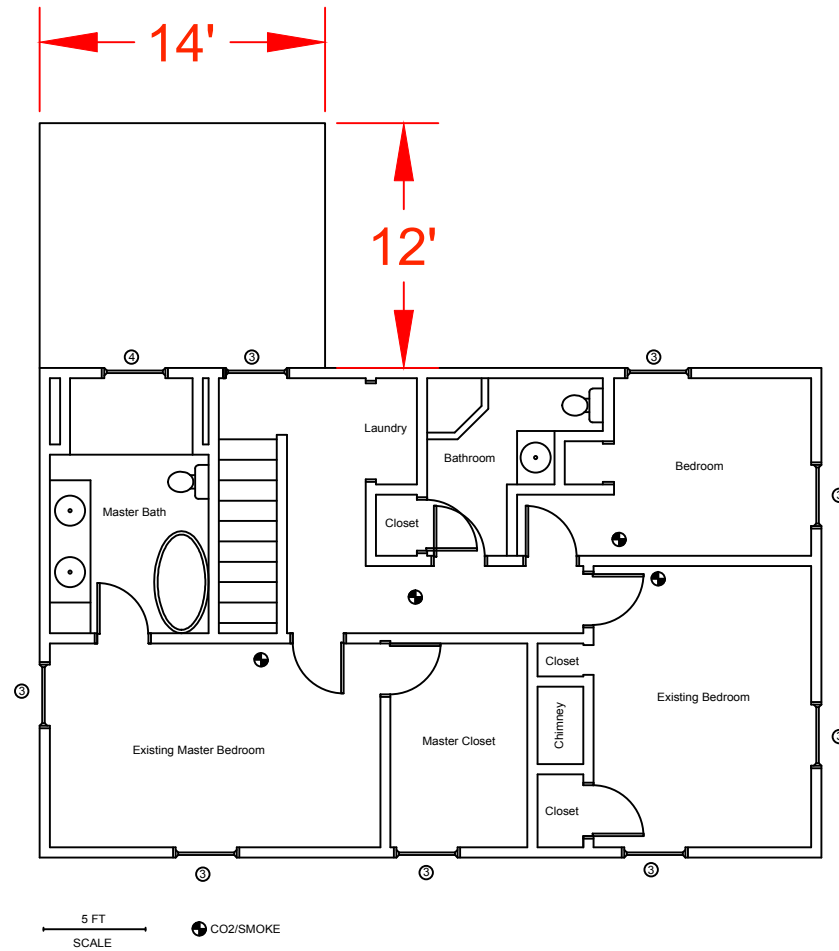

SECOND FLOOR PLAN VIEW (PROPOSED)

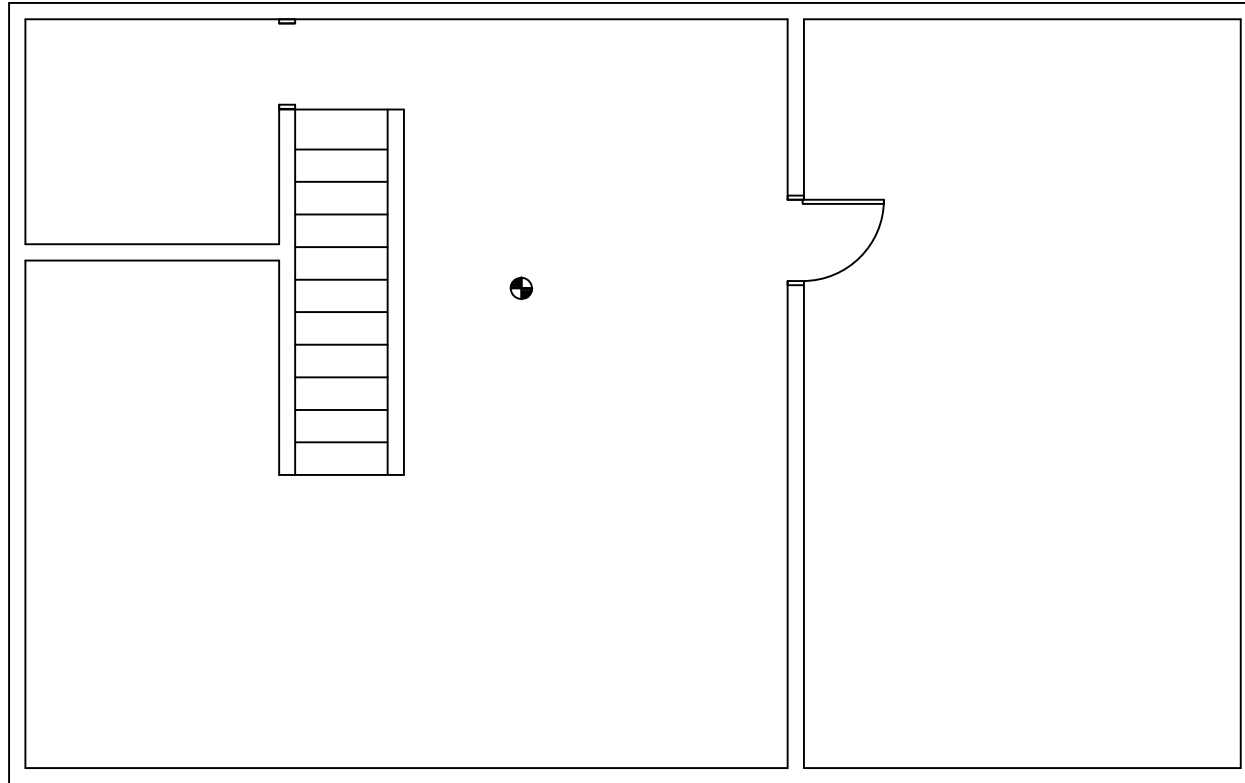

5 FT
SCALE

● CO2/SMOKE

BASEMENT PLAN VIEW (PROPOSED)



5 FT
SCALE

FRONT ELEVATION (PROPOSED)

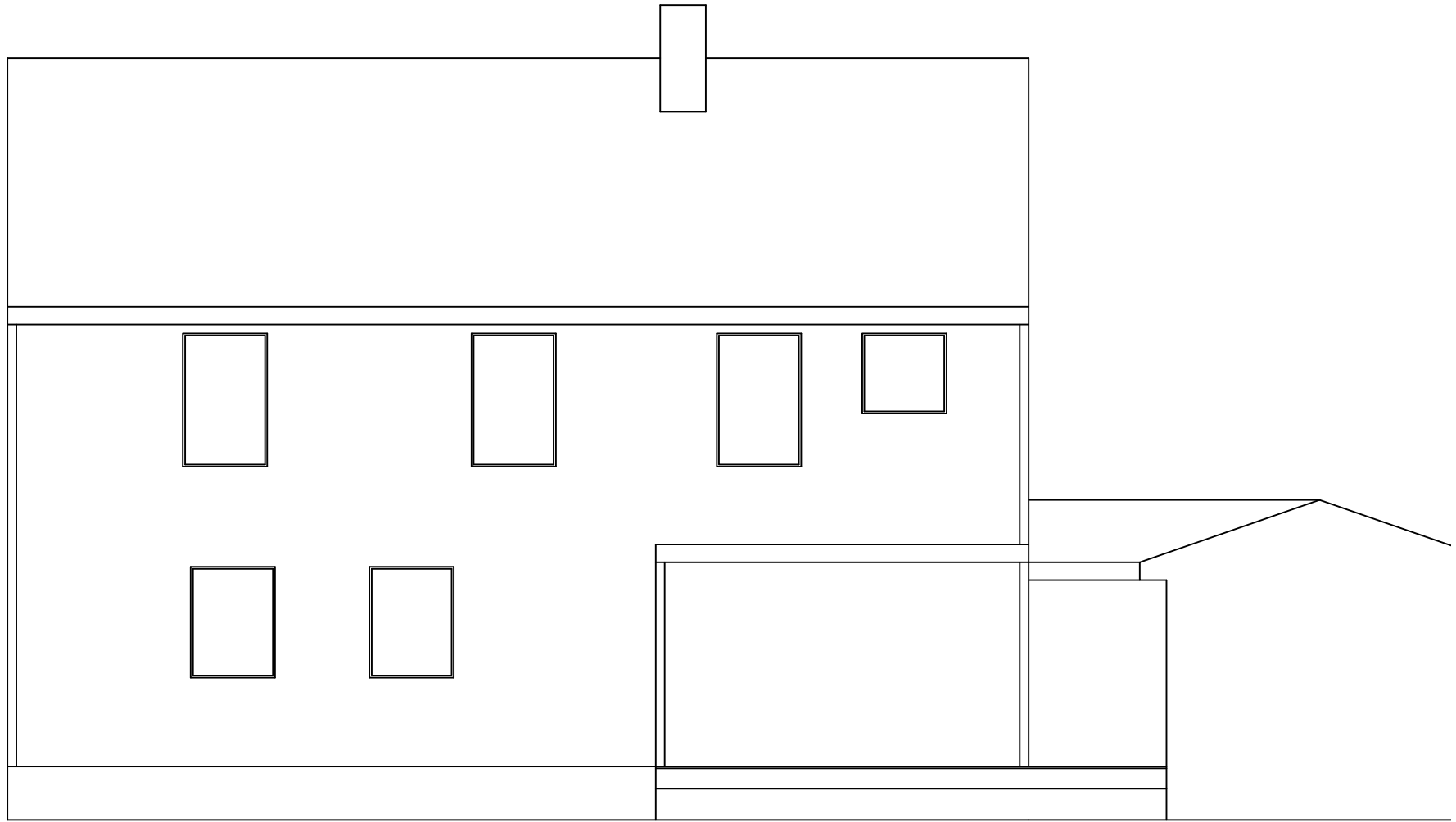

5 FT
SCALE

BACK ELEVATION (PROPOSED)

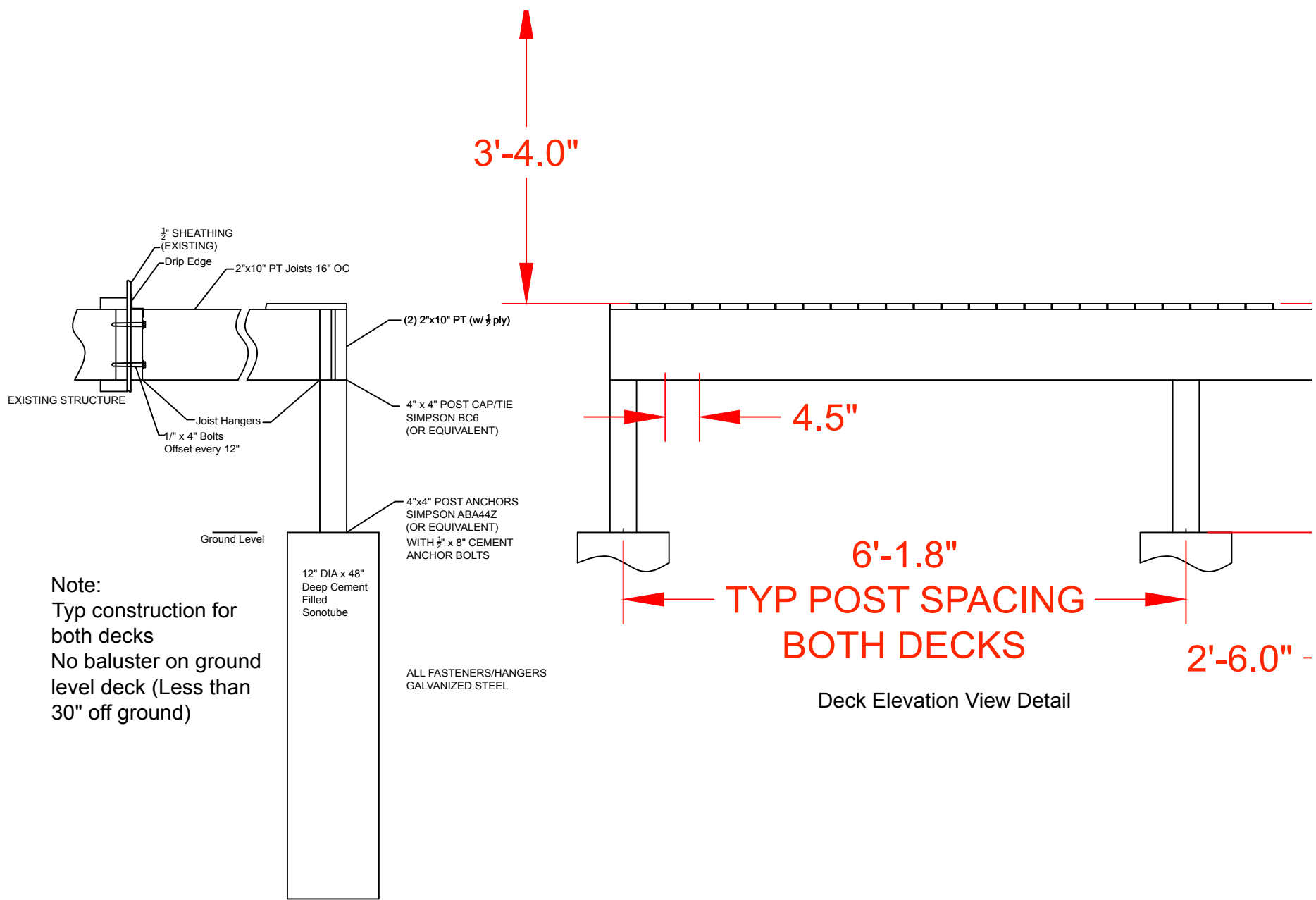

Deck Side View Detail 1
 (Connection to Existing House Structure)

1 FT
 SCALE

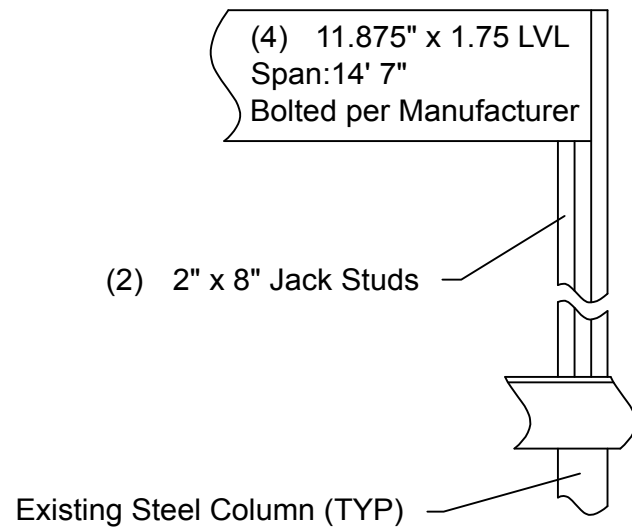

1 FT
SCALE

Notes:

- 1. All window/door headers (2) 2" x 8"
- 2. Insulation R19 for first story (Existing 2" x 4" Construction).

LVL DETAIL

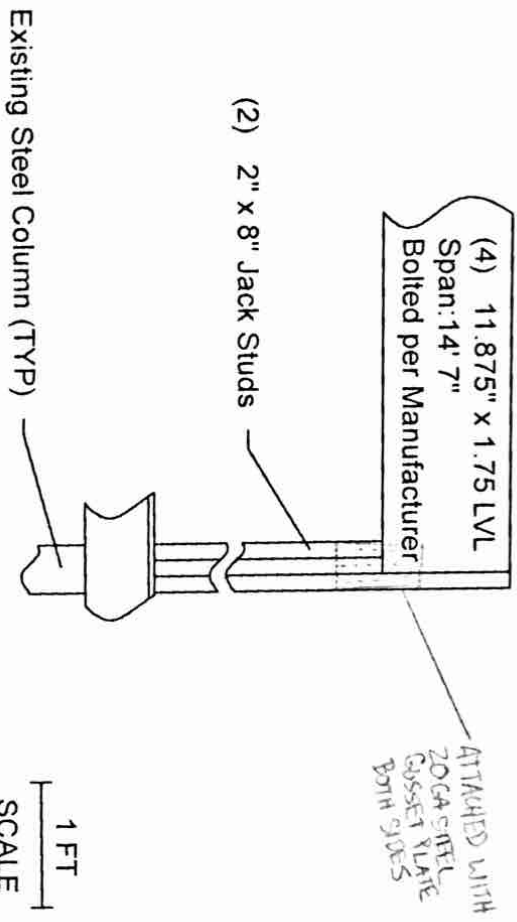

- Notes:
1. All window/door headers (2) 2" x 6"
 2. Insulation R11 for first story (Existing 2" x 4" Construction).

FRONT ENTRANCE DETAIL

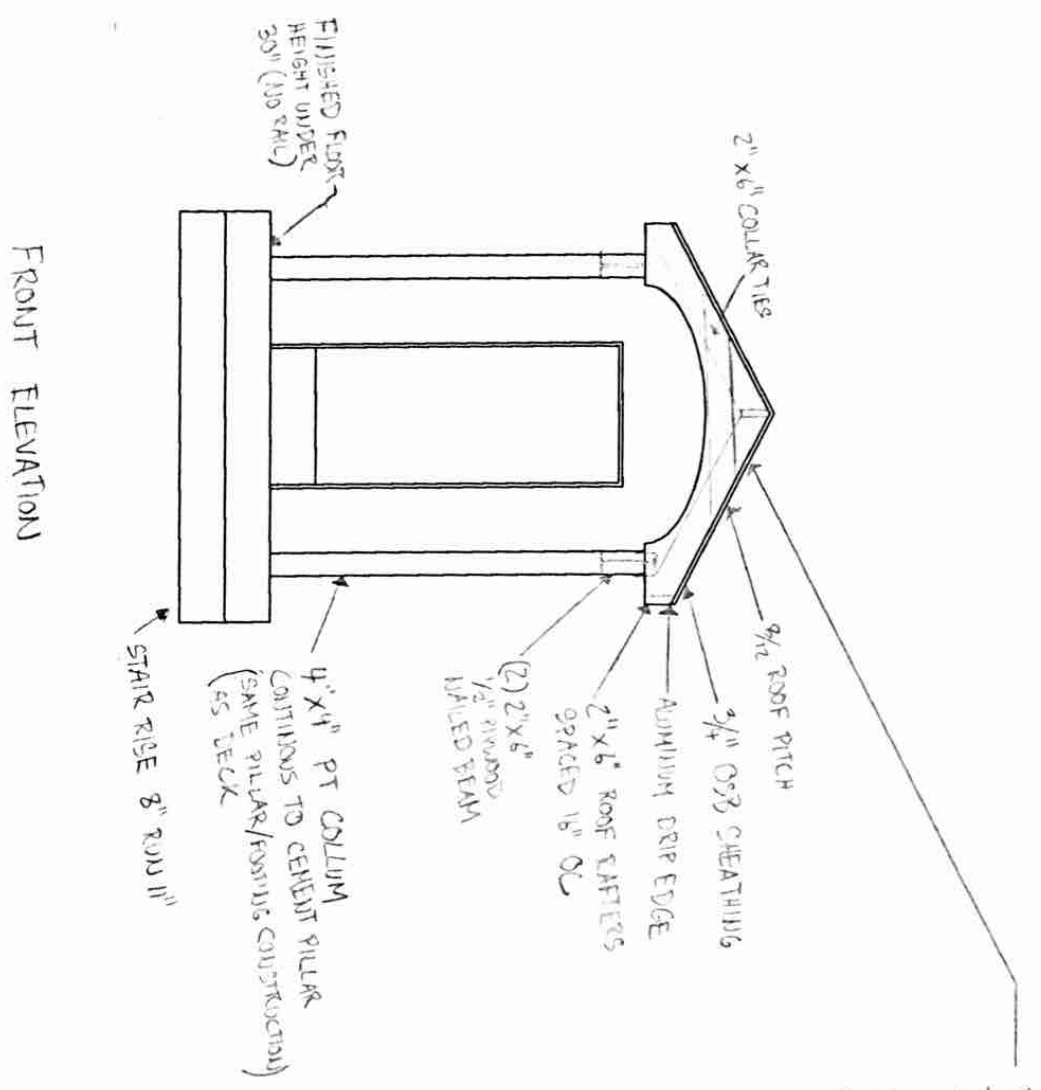

- ROOF COVERING NOTES
- ICE + WATER SHIELD ABOVE LOWER ROOF LINE AND SEAMS
 - 3 TAB ASPHALT SHINGLE
 - ROOF RAFTER/LEDGER ABOVE THIS HOUSE SHEATHING NILED TO INTER FLOOR JOISTS/GUIDS WITH 3" RING NAILS

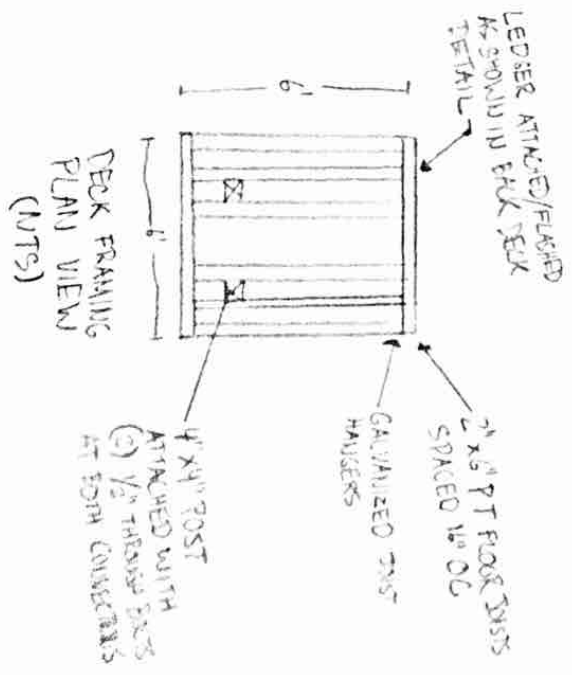

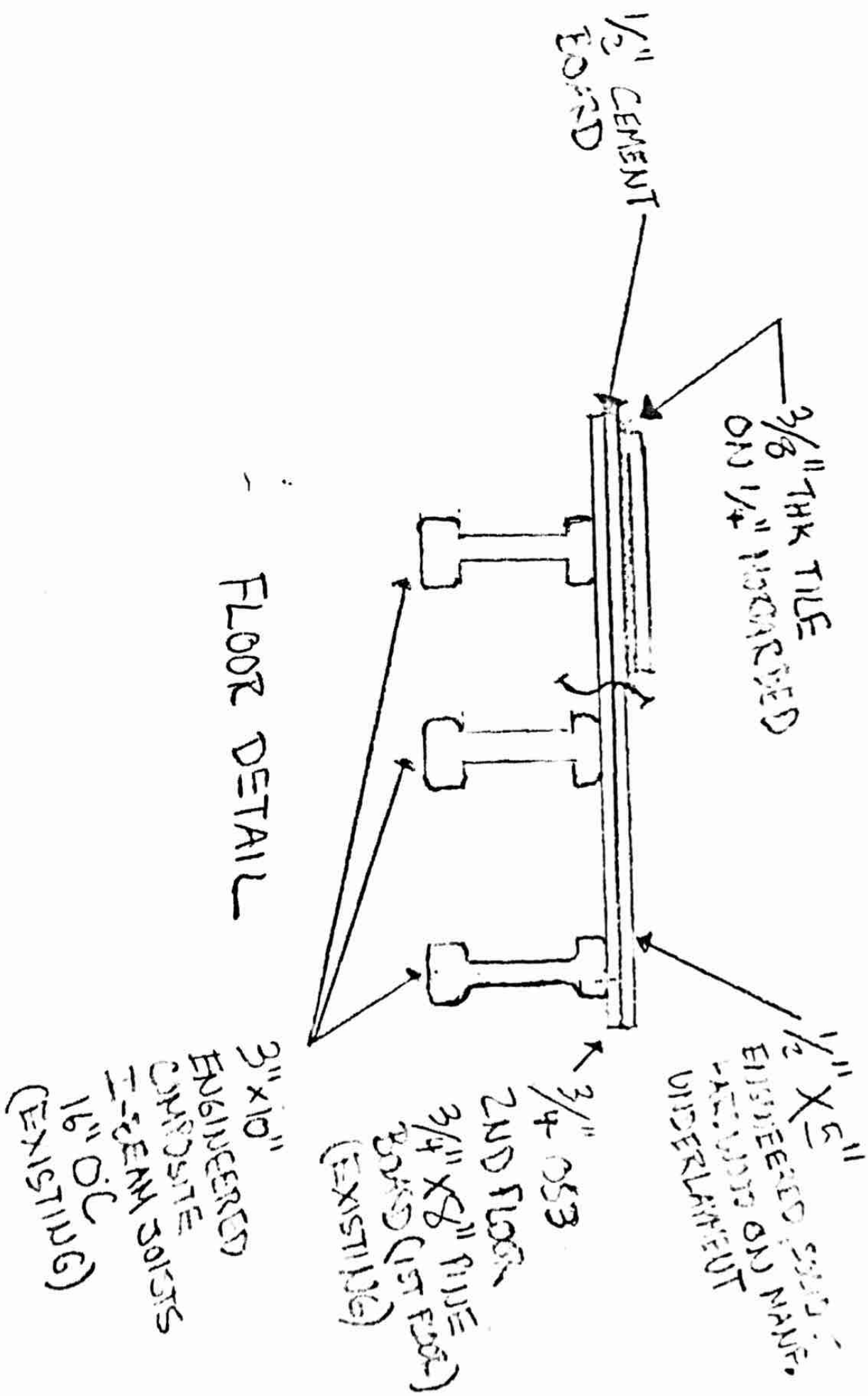

FLOOR DETAIL

Window and Door Schedule

Indicator	Size (H"xW")	Height (floor to sill)	Type	
1	46 x 30	32	Double Hung	Existing
2	56 x 30	24	Double Hung	Proposed
3	56 x 30	24	Double Hung	Existing
4	36 x 32	46	Double Hung	Existing
5	36 x 32	42	Double Hung	Proposed
6	36 x 30	42	Double Hung	Existing
7	80 x 36	N/A	Single Hinge	Replacement